



Mitsubishi Programmable Controller

MELSEC *L* series

# MELSEC-L CC-Link System Master/Local Module User's Manual

---

-L26CPU-BT  
-L26CPU-PBT  
-LJ61BT11

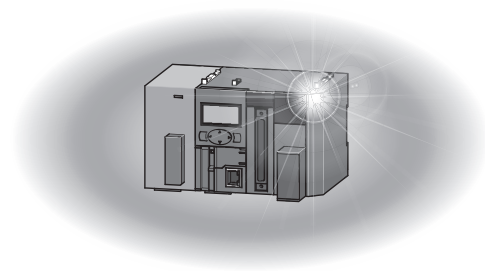



# ● SAFETY PRECAUTIONS ●

(Read these precautions before using this product.)

Before using this product, please read this manual and the relevant manuals carefully and pay full attention to safety to handle the product correctly.

The precautions given in this manual are concerned with this product only. For the safety precautions of the programmable controller system, refer to the user's manual for the CPU module used.

In this manual, the safety precautions are classified into two levels: "⚠ WARNING" and "⚠ CAUTION".



Indicates that incorrect handling may cause hazardous conditions, resulting in death or severe injury.



Indicates that incorrect handling may cause hazardous conditions, resulting in minor or moderate injury or property damage.

Under some circumstances, failure to observe the precautions given under "⚠ CAUTION" may lead to serious consequences.

Observe the precautions of both levels because they are important for personal and system safety.

Make sure that the end users read this manual and then keep the manual in a safe place for future reference.

## [Design Precautions]

### **WARNING**

- For the operating status of each station after a communication failure, refer to Page 136, Section 8.2.6 in this manual.

Incorrect output or malfunction due to a communication failure may result in an accident.

- When connecting a peripheral with the CPU module or connecting an external device, such as a personal computer, with an intelligent function module to modify data of a running programmable controller, configure an interlock circuit in the program to ensure that the entire system will always operate safely.

For other forms of control (such as program modification or operating status change) of a running programmable controller, read the relevant manuals carefully and ensure that the operation is safe before proceeding.

Especially, when a remote programmable controller is controlled by an external device, immediate action cannot be taken if a problem occurs in the programmable controller due to a communication failure.

To prevent this, configure an interlock circuit in the program, and determine corrective actions to be taken between the external device and CPU module in case of a communication failure.

- Do not write any data to the "system area" of the buffer memory in the intelligent function module. Also, do not use any "use prohibited" signals as an output signal from the CPU module to the intelligent function module.

Doing so may cause malfunction of the programmable controller system.

- To set the auto refresh parameter, select the device Y for the remote output (RY) refresh device. If a device other than Y, such as M and L, is selected, the CPU module holds the device status even after its status is changed to STOP.

For how to stop a data link, refer to Page 186, Section 8.3.8.

- If a CC-Link dedicated cable is disconnected, the network may be unstable, resulting in a communication failure of multiple stations.

Configure an interlock circuit in the program to ensure that the entire system will always operate safely even if communications fail.

Failure to do so may result in an accident due to an incorrect output or malfunction.

## [Design Precautions]

### **CAUTION**

- Do not install the control lines or communication cables together with the main circuit lines or power cables.

Keep a distance of 100mm or more between them.

Failure to do so may result in malfunction due to noise.



## [Installation Precautions]

### **WARNING**

- Shut off the external power supply (all phases) used in the system before mounting or removing a module.  
Failure to do so may result in electric shock or cause the module to fail or malfunction.

## [Installation Precautions]

### **CAUTION**

- Use the programmable controller in an environment that meets the general specifications in the Safety Guidelines provided with the CPU module or head module.  
Failure to do so may result in electric shock, fire, malfunction, or damage to or deterioration of the product.
- To interconnect modules, engage the respective connectors and securely lock the module joint levers until they click.  
Incorrect interconnection may cause malfunction, failure, or drop of the module.
- Do not directly touch any conductive parts and electronic components of the module.  
Doing so can cause malfunction or failure of the module.

## [Wiring Precautions]

### **WARNING**

- Shut off the external power supply (all phases) used in the system before wiring.  
Failure to do so may result in electric shock or cause the module to fail or malfunction.
- After installation and wiring, attach the included terminal cover to the module before turning it on for operation.  
Failure to do so may result in electric shock.

## [Wiring Precautions]

### CAUTION

- Use applicable solderless terminals and tighten them within the specified torque range.  
If any spade solderless terminal is used, it may be disconnected when a terminal block screw comes loose, resulting in failure.
- Do not install the control lines or communication cables together with the main circuit lines or power cables.  
Failure to do so may result in malfunction due to noise.
- Place the cables in a duct or clamp them.  
If not, dangling cable may swing or inadvertently be pulled, resulting in damage to the module or cables or malfunction due to poor contact.
- Tighten the terminal block screws within the specified torque range.  
Undertightening can cause short circuit or malfunction.  
Overtightening can damage the screw and/or module, resulting in drop, short circuit, fire, or malfunction.
- When disconnecting the cable from the module, do not pull the cable by the cable part.  
For the cable with connector, hold the connector part of the cable.  
For the cable connected to the terminal block, loosen the terminal screw.  
Pulling the cable connected to the module may result in malfunction or damage to the module or cable.
- Prevent foreign matter such as dust or wire chips from entering the module.  
Such foreign matter can cause a fire, failure, or malfunction.
- A protective film is attached to the top of the module to prevent foreign matter, such as wire chips, from entering the module during wiring.  
Do not remove the film during wiring.  
Remove it for heat dissipation before system operation.
- For the CC-Link system, use dedicated cables that are specified by the manufacturer.  
If not, the performance of the CC-Link system is not guaranteed.  
Also, the maximum overall cable length and the station-to-station cable length must meet those specified in Page 25, CHAPTER 3.  
If not, normal data transmission is not guaranteed.

## [Startup and Maintenance Precautions]

### WARNING

- Do not touch any terminal while power is on.  
Doing so will cause electric shock or malfunction.
- Shut off the external power supply (all phases) used in the system before cleaning the module or retightening the terminal block screws.  
Failure to do so may result in electric shock.

## [Startup and Maintenance Precautions]

### CAUTION

- Do not disassemble or modify the modules.  
Doing so may cause failure, malfunction, injury, or a fire.
- Shut off the external power supply (all phases) used in the system before mounting or removing a module.  
Failure to do so may cause the module to fail or malfunction.
- Tighten the terminal block screws within the specified torque range.  
Undertightening can cause drop of the component or wire, short circuit, or malfunction.  
Overtightening can damage the screw and/or module, resulting in drop, short circuit, or malfunction.
- After the first use of the product (module and terminal block), do not connect/disconnect the product more than 50 times (in accordance with IEC 61131-2).  
Exceeding the limit may cause malfunction.
- Before handling the module, touch a conducting object such as a grounded metal to discharge the static electricity from the human body.  
Failure to do so may cause the module to fail or malfunction.

## [Disposal Precautions]

### CAUTION

- When disposing of this product, treat it as industrial waste.

# ● CONDITIONS OF USE FOR THE PRODUCT ●

- (1) Mitsubishi programmable controller ("the PRODUCT") shall be used in conditions;
  - i) where any problem, fault or failure occurring in the PRODUCT, if any, shall not lead to any major or serious accident; and
  - ii) where the backup and fail-safe function are systematically or automatically provided outside of the PRODUCT for the case of any problem, fault or failure occurring in the PRODUCT.
  
- (2) The PRODUCT has been designed and manufactured for the purpose of being used in general industries.

MITSUBISHI SHALL HAVE NO RESPONSIBILITY OR LIABILITY (INCLUDING, BUT NOT LIMITED TO ANY AND ALL RESPONSIBILITY OR LIABILITY BASED ON CONTRACT, WARRANTY, TORT, PRODUCT LIABILITY) FOR ANY INJURY OR DEATH TO PERSONS OR LOSS OR DAMAGE TO PROPERTY CAUSED BY the PRODUCT THAT ARE OPERATED OR USED IN APPLICATION NOT INTENDED OR EXCLUDED BY INSTRUCTIONS, PRECAUTIONS, OR WARNING CONTAINED IN MITSUBISHI'S USER, INSTRUCTION AND/OR SAFETY MANUALS, TECHNICAL BULLETINS AND GUIDELINES FOR the PRODUCT.

("Prohibited Application")

Prohibited Applications include, but not limited to, the use of the PRODUCT in;

- Nuclear Power Plants and any other power plants operated by Power companies, and/or any other cases in which the public could be affected if any problem or fault occurs in the PRODUCT.
- Railway companies or Public service purposes, and/or any other cases in which establishment of a special quality assurance system is required by the Purchaser or End User.
- Aircraft or Aerospace, Medical applications, Train equipment, transport equipment such as Elevator and Escalator, Incineration and Fuel devices, Vehicles, Manned transportation, Equipment for Recreation and Amusement, and Safety devices, handling of Nuclear or Hazardous Materials or Chemicals, Mining and Drilling, and/or other applications where there is a significant risk of injury to the public or property.

Notwithstanding the above, restrictions Mitsubishi may in its sole discretion, authorize use of the PRODUCT in one or more of the Prohibited Applications, provided that the usage of the PRODUCT is limited only for the specific applications agreed to by Mitsubishi and provided further that no special quality assurance or fail-safe, redundant or other safety features which exceed the general specifications of the PRODUCTS are required. For details, please contact the Mitsubishi representative in your region.

# INTRODUCTION

---

Thank you for purchasing the Mitsubishi MELSEC-L series programmable controllers.



This manual explains the functions and programming required to use the L26CPU-BT/L26CPU-PBT built-in CC-Link system master/local function and the LJ61BT11 CC-Link system master/local module (hereinafter referred to as the L series master/local module).

Before using this product, please read this manual and the relevant manuals carefully and develop familiarity with the functions and performance of the MELSEC-L series programmable controller to handle the product correctly.

When applying the program examples introduced in this manual to an actual system, ensure the applicability and confirm that it will not cause system control problems.

Please make sure that the end users read this manual.

## Remark



- Unless otherwise specified, this manual describes the program examples in which the I/O numbers of X/Y00 to X/Y1F are assigned for a L series master/local module. I/O numbers must be assigned to apply the program examples introduced in this manual to an actual system.  
For I/O number assignment, refer to the following.  
 MELSEC-L CPU Module User's Manual (Function Explanation, Program Fundamentals)
- Operating procedures are explained using GX Works2. When using GX Developer, refer to  Page 461, Appendix 8.

# COMPLIANCE WITH EMC AND LOW VOLTAGE DIRECTIVES

---

## (1) Method of ensuring compliance

To ensure that Mitsubishi programmable controllers maintain EMC and Low Voltage Directives when incorporated into other machinery or equipment, certain measures may be necessary. Please refer to one of the following manuals.

-  MELSEC-L CPU Module User's Manual (Hardware Design, Maintenance and Inspection)
-  MELSEC-L CC-Link IE Field Network Head Module User's Manual
- Safety Guidelines

(This manual is included with the CPU module or head module.)

The CE mark on the side of the programmable controller indicates compliance with EMC and Low Voltage Directives.

## (2) Additional measures

To ensure that this product maintains EMC and Low Voltage Directives, please refer to one of the manuals listed under (1).

# RELEVANT MANUALS

## (1) CPU module user's manual

Manual name <manual number (model code)>	Description
MELSEC-L CPU Module User's Manual (Hardware Design, Maintenance and Inspection) <SH-080890ENG, 13JZ36>	Specifications of the CPU modules, power supply modules, display unit, branch module, extension module, SD memory cards, and batteries, information on how to establish a system, maintenance and inspection, and troubleshooting
MELSEC-L CPU Module User's Manual (Function Explanation, Program Fundamentals) <SH-080889ENG, 13JZ35>	Functions and devices of the CPU module, and programming

## (2) Head module User's Manual

Manual name <manual number (model code)>	Description
MELSEC-L CC-Link IE Field Network Head Module User's Manual <SH-080919ENG, 13JZ48>	Specifications, procedures before operation, system configuration, installation, wiring, settings, and troubleshooting of the head module

## (3) Operating manual

Manual name <manual number (model code)>	Description
GX Works2 Version1 Operating Manual (Common) <SH-080779ENG, 13JU63>	System configuration, parameter settings, and online operations of GX Works2, which are common to Simple projects and Structured projects
GX Developer Version 8 Operating Manual <SH-080373E, 13JU41>	Operating methods of GX Developer, such as programming, printing, monitoring, and debugging

## (4) Others

Manual name <manual number (model code)>	Description
iQ Sensor Solution Reference Manual <SH-081133ENG, 13JV28>	Operating methods of iQ Sensor Solution, such as programming and monitoring

# CONTENTS

SAFETY PRECAUTIONS .....	1
CONDITIONS OF USE FOR THE PRODUCT .....	6
INTRODUCTION .....	7
COMPLIANCE WITH EMC AND LOW VOLTAGE DIRECTIVES .....	8
RELEVANT MANUALS .....	9
TERMS .....	15
PACKING LIST .....	17
<hr/>	
<b>CHAPTER 1 FEATURES</b> .....	<b>18</b>
<hr/>	
1.1 CC-Link .....	18
1.2 Overview of Communication .....	19
<hr/>	
<b>CHAPTER 2 PART NAMES</b> .....	<b>22</b>
<hr/>	
<b>CHAPTER 3 SPECIFICATIONS</b> .....	<b>25</b>
<hr/>	
3.1 General Specifications .....	25
3.2 Performance Specifications .....	26
3.2.1 Maximum number of connected stations .....	28
3.2.2 Maximum overall cable distance .....	30
3.2.3 Ver.1.10 compatible CC-Link dedicated cable .....	31
3.3 Function List .....	32
3.4 Mode Selection .....	35
3.4.1 Expanded cyclic setting .....	37
3.5 I/O Signal List .....	45
3.6 Buffer Memory List .....	47
<hr/>	
<b>CHAPTER 4 PROCEDURE BEFORE OPERATION</b> .....	<b>50</b>
<hr/>	
<b>CHAPTER 5 SYSTEM CONFIGURATION</b> .....	<b>52</b>
<hr/>	
5.1 System Configuration .....	52
5.1.1 System configuration of the L series master/local modules .....	52
5.1.2 System configuration on CC-Link .....	53
5.2 Applicable System .....	54
5.2.1 Applicable modules and number of connectable modules .....	54
5.2.2 Restrictions on use with the head module .....	54
5.2.3 Precautions on the system configuration .....	55
<hr/>	
<b>CHAPTER 6 INSTALLATION AND CONNECTION</b> .....	<b>58</b>
<hr/>	
6.1 Module Installation Environment and Position .....	58
6.1.1 Handling precautions .....	58
6.2 Hardware Test .....	60
6.3 Connecting Modules with Ver.1.10 Compatible CC-Link Dedicated Cables .....	62
6.3.1 Wiring check .....	64
6.4 T-Branch Connection .....	65



6.4.1	T-branch system configuration	65
6.4.2	T-branch communication specifications list	66
6.5	Loop Test	67
6.5.1	Loop test 1	68
6.5.2	Loop test 2	70

---

<b>CHAPTER 7 PARAMETER SETTINGS</b>	<b>72</b>
-------------------------------------	-----------

---

7.1	Parameter Setting Method	72
7.2	Parameter Setting List	74
7.3	Parameter Settings for a Master Station	76
7.3.1	Setting method	76
7.3.2	Setting details	77
7.4	Parameter Settings for a Local Station and Standby Master Station	98
7.4.1	Setting method	98
7.4.2	Setting details	99
7.5	Precautions on the Parameter Setting	107

---

<b>CHAPTER 8 FUNCTIONS</b>	<b>110</b>
----------------------------	------------

---

8.1	Basic Functions	110
8.1.1	Communication with remote I/O stations	110
8.1.2	Communication with remote device stations	113
8.1.3	Communication with local stations	118
8.1.4	Communication with intelligent device stations	124
8.2	Functions for Improving System Reliability	130
8.2.1	Slave station cut-off function	130
8.2.2	Automatic return function	131
8.2.3	Data link status setting in case of master station programmable controller CPU failure	132
8.2.4	Setting the status of input data from a data link faulty station	133
8.2.5	Slave station refresh/compulsory clear setting in case of programmable controller CPU STOP	134
8.2.6	Station status at error occurrence	136
8.2.7	Standby master function	140
8.2.8	Data link start by standby master station	156
8.2.9	Block guarantee of cyclic data per station	159
8.2.10	Secured 32-bit data	164
8.3	Handy Functions	165
8.3.1	Remote device station initialization procedure registration function	165
8.3.2	Event issuance for the interrupt program	172
8.3.3	Automatic CC-Link startup	176
8.3.4	Reserved station function	178
8.3.5	Error invalid station setting function	179
8.3.6	Temporary error invalid station setting function	180
8.3.7	Scan synchronous function	182
8.3.8	Data link stop/restart	186
8.3.9	Remote I/O station points setting	188
8.3.10	Master station duplication error cancel function	190

---

**CHAPTER 9 DEDICATED INSTRUCTIONS AND PROGRAMMING** 191

---

9.1	Dedicated Instructions	191
9.1.1	Dedicated instruction list, applicable devices, and precautions	191
9.1.2	G(P).RIRD	193
9.1.3	G(P).RIWT	199
9.1.4	G(P).RIRCV	205
9.1.5	G(P).RISEND	210
9.1.6	G(P).RIFR	215
9.1.7	G(P).RITO	218
9.1.8	G(P).RLPASET	221
9.1.9	G(P).RDMSG	236
9.2	Precautions on Programming	241

---

**CHAPTER 10 EXAMPLE OF COMMUNICATION BETWEEN THE MASTER STATION AND REMOTE I/O STATIONS** 242

---

10.1	When Remote I/O Net Mode is Used	242
10.1.1	Configuring a system	242
10.1.2	Parameter setting	244
10.1.3	Creating a program	246
10.1.4	Performing the data link	247

---

**CHAPTER 11 EXAMPLE OF COMMUNICATION BETWEEN THE MASTER STATION AND REMOTE DEVICE STATIONS** 249

---

11.1	When Remote Net Ver.1 Mode is Used	249
11.1.1	Configuring a system	249
11.1.2	Parameter setting	251
11.1.3	Creating a program	255
11.1.4	Performing the data link	258
11.2	When Remote Net Ver.2 Mode is Used	260
11.2.1	Configuring a system	260
11.2.2	Parameter setting	263
11.2.3	Creating a program	267
11.2.4	Performing the data link	271
11.3	When Remote Net Additional Mode is Used	273
11.3.1	Configuring a system	273
11.3.2	Parameter setting	276
11.3.3	Creating a program	280
11.3.4	Performing the data link	284

---

**CHAPTER 12 EXAMPLE OF COMMUNICATION BETWEEN THE MASTER STATION AND LOCAL STATIONS** 286

---

12.1	When Remote Net Ver.1 Mode is Used	286
12.1.1	Configuring a system	286
12.1.2	Setting the master station parameters	287
12.1.3	Setting the local station parameters	289

12.1.4	Creating a program	291
12.1.5	Performing the data link	295
12.2	When Remote Net Ver.2 Mode is Used	297
12.2.1	Configuring a system	297
12.2.2	Setting the master station parameters	298
12.2.3	Setting the local station parameters	300
12.2.4	Creating a program	304
12.2.5	Performing the data link	308
12.3	When Remote Net Additional Mode is Used	310
12.3.1	Configuring a system	310
12.3.2	Setting the master station parameters	311
12.3.3	Setting the local station parameters	313
12.3.4	Creating a program	317
12.3.5	Performing the data link	321

---

<b>CHAPTER 13 COMMUNICATION BETWEEN THE MASTER STATION AND INTELLIGENT DEVICE STATIONS</b>	<b>323</b>
--	------------

---

<b>CHAPTER 14 EXAMPLE OF COMMUNICATION WHEN USING THE HEAD MODULE</b>	<b>325</b>
---	------------

---

14.1	System Configuration Example	325
14.2	Image of Link Scan and Link Refresh by Cyclic Transmission	326
14.3	Parameter Settings	327
14.3.1	Setting parameters of the CC-Link IE Field Network master station	327
14.3.2	Setting parameters of the head module	329
14.4	Program Example of CC-Link IE Field Network Master Station	332

---

<b>CHAPTER 15 TROUBLESHOOTING</b>	<b>335</b>
-----------------------------------	------------

---

15.1	Troubleshooting Procedures	336
15.1.1	Flowcharts for troubleshooting by LEDs	336
15.1.2	Flowcharts for troubleshooting by GX Works2	339
15.2	List of Problems	345
15.2.1	When disconnecting a slave station	345
15.2.2	When cyclic data are faulty	353
15.2.3	When transient data are faulty	356
15.2.4	When operation of the master station is faulty	357
15.3	Error Codes	358
15.3.1	How to check error codes	358
15.3.2	Error code list	362
15.4	CC-Link Diagnostics	375
15.4.1	Host monitoring/Other station monitoring	375
15.4.2	Loop test/Obtain transmission speed setting	378
15.4.3	Status logging	380
15.4.4	Creating a check sheet	382
15.4.5	H/W information	384

Appendix 1	Details of the I/O Signals . . . . .	387
Appendix 2	Buffer Memory Details . . . . .	389
Appendix 3	Link Special Relays and Registers (SB/SW) . . . . .	409
Appendix 3.1	Link special relays (SB) . . . . .	410
Appendix 3.2	Link special registers (SW) . . . . .	416
Appendix 4	Data Link Processing Time . . . . .	430
Appendix 4.1	Link scan time . . . . .	430
Appendix 4.2	Transmission delay time of master station <-> remote I/O station . . . . .	435
Appendix 4.3	Transmission delay time of master station <-> remote device station (Ver.1 compatible slave station) . . . . .	437
Appendix 4.4	Transmission delay time of master station <-> remote device station (Ver.2 compatible slave station) . . . . .	439
Appendix 4.5	Transmission delay time of master station <-> local station (Ver.1 compatible slave station) . . . . .	441
Appendix 4.6	Transmission delay time of master station <-> local station (Ver.2 compatible slave station) . . . . .	443
Appendix 4.7	Transmission delay time of master station <-> intelligent device station . . . . .	445
Appendix 4.8	Processing time for dedicated instructions of master station <-> local station . . . . .	446
Appendix 4.9	Processing time for dedicated instructions of local station <-> local station . . . . .	450
Appendix 4.10	Processing time for dedicated instructions of master station <-> intelligent device station . . . . .	452
Appendix 4.11	Link refresh time of master station/local station . . . . .	454
Appendix 5	How to Confirm the Serial No. and Function Version . . . . .	458
Appendix 6	Added Functions . . . . .	459
Appendix 7	Differences Between the L Series Master/Local Module and QJ61BT11N . . . . .	460
Appendix 7.1	Specification comparison . . . . .	460
Appendix 7.2	Precautions when utilizing the program . . . . .	460
Appendix 8	When Using the GX Developer . . . . .	461
Appendix 8.1	Compatible software package . . . . .	461
Appendix 8.2	Operation comparison . . . . .	461
Appendix 9	External Dimensions . . . . .	467

REVISIONS . . . . .	472
WARRANTY . . . . .	473
TRADEMARKS . . . . .	474

# TERMS

The following shows the terms used in this manual.

Term	Description
AnUCPU	Another term for the MELSEC-AnU series CPU module
Buffer memory	A memory in an intelligent function module, where data (such as setting values and monitoring values) exchanged with a CPU module are stored
Buffer memory address	An address that indicates the storage location of data assigned to the buffer memory in an intelligent function module
Built-in CC-Link function	The abbreviation for the L26CPU-BT/L26CPU-PBT built-in CC-Link system master/local function
Cyclic transmission	A function by which data are periodically exchanged among stations on the same system using link devices (RX, RY, RWw, and RWr)
Data link	A generic term for cyclic transmission and transient transmission
Dedicated instruction	An instruction that simplifies programming for using functions of intelligent function modules and special function modules
Disconnection	A process of stopping data link if a data link error occurs
GX Developer	The product name of the software package for the MELSEC programmable controllers
GX Works2	
Head module	The abbreviation for the LJ72GF15-T2 CC-Link IE Field Network head module
Intelligent device module	A generic term for the modules that can perform transient transmission, such as the AJ65BT-R2N (including local module)
Intelligent device station	A station that exchanges I/O signals (bit data) and I/O data (word data) with another station by cyclic transmission. This station can perform transient transmission. This station responds to a transient transmission request from another station. The station also issues a transient transmission request to another station.
Intelligent function module	A MELSEC-Q/L series module that has functions other than input and output, such as an A/D converter module and D/A converter module
L series master/local module	A generic term for the Built-in CC-Link function and LJ61BT11
LCPU	Another term for the MELSEC-L series CPU module
Link scan (link scan time)	Time required for all stations in a system to transmit data. The link scan time depends on data volume and the number of transient transmission requests.
Link special register (SW)	Word data that indicates the operating status and data link status of modules on the master and local stations
Link special relay (SB)	Bit data that indicates the operating status and data link status of modules on the master and local stations
LJ61BT11	The abbreviation for the LJ61BT11 CC-Link system master/local module
Local module	A generic term for master/local modules when they are used as local station
Local station	A station that performs cyclic transmission and transient transmission with the master station and other local stations. The station is controlled by programs in the CPU module or other equivalent modules on the station.
Master module	A generic term for master/local modules when they are used as master station
Master station	A station that controls the entire system. This station can perform cyclic transmission and transient transmission with all stations. Only one master station can be used in a system.
Master/local module	A generic term for the L series master/local module, QJ61BT11N, A1SJ61BT11, and A1SJ61QBT11
Message transmission	A function to communicate data between a master station and slave stations when the model names of slave stations are read, the data are backed up/restored, or the dedicated instructions are requested
Offline	Status that offline, loop test, or H/W test is selected in the mode setting of network parameter
Online	Status that remote net Ver.1 mode, remote net Ver.2 mode, remote net additional mode, or remote I/O net mode is selected in the mode setting of network parameter
Programming tool	A generic term for GX Works2 and GX Developer

Term	Description
QCPU	Another term for the MELSEC-Q series CPU module
QnACPU	Another term for the MELSEC-QnA series CPU module
Remote device station	A station that exchanges I/O signals (bit data) and I/O data (word data) with another station by cyclic transmission. This station cannot perform transient transmission.
Remote I/O net mode	A mode used to perform high-speed communications in a system consisting of a master station and remote I/O station(s) only
Remote I/O station	A station that exchanges I/O signals (bit data) by cyclic transmission. This station cannot perform transient transmission.
Remote input (RX)	Bit data input from a slave station to the master station (For some areas in a local station, data are input in the opposite direction.)
Remote module	A generic term for AJ65BTB1-16D, AJ65SBTB1-16D, AJ65BT-64AD, AJ65BT-64DAV, AJ65BT-64DAI, and GT15-J61BT13
Remote net additional mode	A mode used to increase the number of link points by adding a Ver.2-compatible slave station to an existing system consisting of Ver.1-compatible slave stations only. Different from the remote net Ver.2 mode, programs in the remote net Ver.1 mode can be used without change because RX/RX/RWr/RWw data of a Ver.1-compatible slave station are stored in the Ver.1-compatible buffer memory areas.
Remote net mode	A mode used to communicate data with all stations (remote I/O station, remote device station, local station, intelligent device station, and standby master station) in a CC-Link system. There are three modes: remote net Ver.1 mode, remote net Ver.2 mode, and remote net additional mode.
Remote net Ver.1 mode	A mode used to configure a CC-Link system consisting of a master station and Ver.1-compatible slave station(s) only
Remote net Ver.2 mode	A mode used to configure a CC-Link system containing a Ver.2-compatible slave station. Compared to the remote net Ver.1 mode, the number of link points per station is increased from 128 to 896 for RX/RX, and from 16 to 128 for RWr/RWw.
Remote output (RY)	Bit data output from the master station to a slave station (For some areas in a local station, data are output in the opposite direction.)
Remote register (RWr)	Word data input from a slave station to the master station (For some areas in a local station, data are input in the opposite direction.)
Remote register (RWw)	Word data output from the master station to a slave station (For some areas in a local station, data are output in the opposite direction.)
Remote station	A generic term for a remote I/O station and a remote device station
Return	A process of restarting data link when a station recovers from an error
Slave station	A generic term for a remote I/O station, remote device station, local station, intelligent device station, and standby master station
Special function module	A MELSEC-QnA/A series module that has functions other than input and output, such as an A/D converter module and D/A converter module
Standby master station	A station that serves as a master station to continue communications if the master station fails
Transient transmission	A function of communication with another station, which is used when requested by a dedicated instruction or a programming tool
Ver.1-compatible slave station	A slave station that supports the remote net Ver.1 mode
Ver.2-compatible slave station	A slave station that supports the remote net Ver.2 mode

# PACKING LIST

The LJ61BT11 package contains the following items. Before using the product, check if all of them are in the package. For the packaged items for the L26CPU-BT and L26CPU-PBT, refer to the MELSEC-L CPU Module User's Manual (Hardware Design, Maintenance and Inspection).

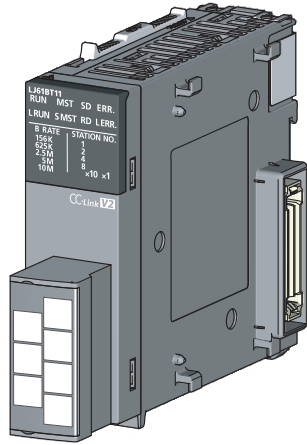

LJ61BT11 module

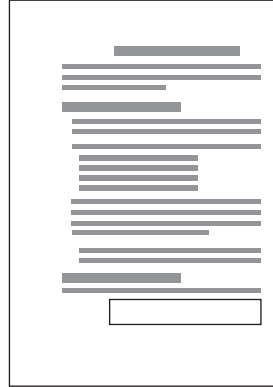

Safety Guidelines

A set of terminating resistors

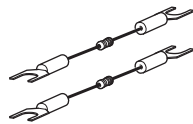

- Terminating resistor 110Ω 1/2W × 2 pieces (Brown-Brown-Brown, gold)



- "CAUTION" note

# CHAPTER 1 FEATURES

## 1.1 CC-Link

CC-Link is a system where distributed modules, such as I/O modules and intelligent function modules, are connected using dedicated cables, enabling a CPU module to control the modules.

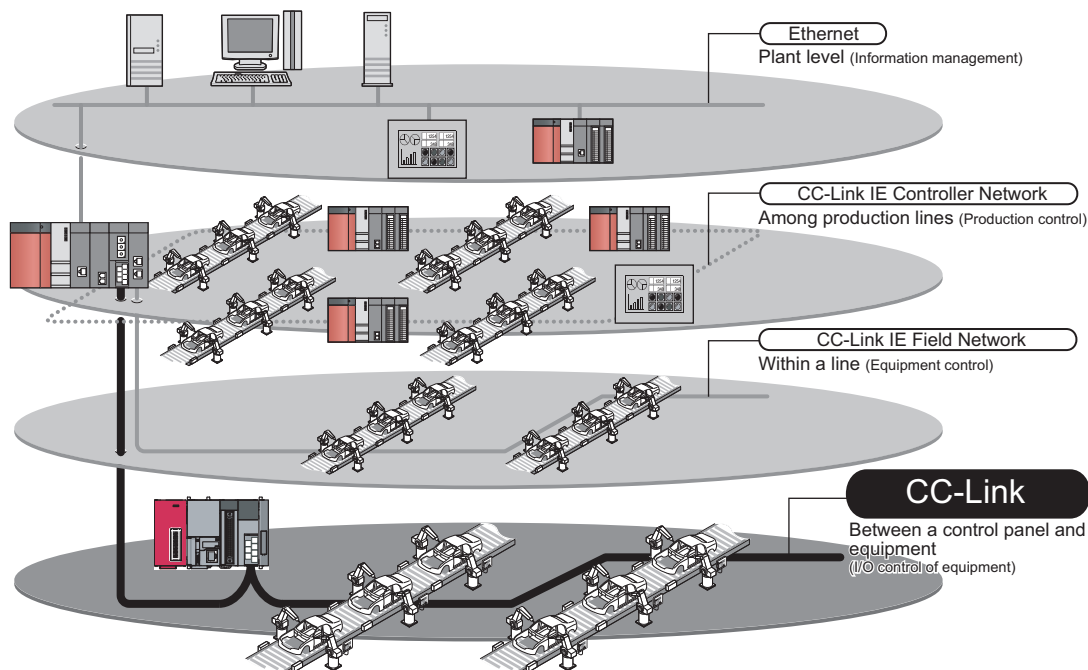

### (1) High-speed communications

On/off information of I/O signals and values can be smoothly exchanged at high speed. This feature allows the configuration of a variety of systems.

### (2) System with reduced wiring

Because modules can be distributed in large equipment, such as conveyor lines and machines, a system with reduced wiring can be achieved.

### (3) Flexible system design

Various CC-Link devices manufactured by partner vendors are available. Therefore, a system can be flexibly designed according to application.

### (4) Configuration of a distributed system

By connecting multiple programmable controllers to a CC-Link system, a simple distributed system can be configured. The multiple programmable controllers can perform data link with remote stations and intelligent device stations and can control distributed devices in a CC-Link system.



# 1.2 Overview of Communication

The overview of CC-Link communication is described below.

## (1) Remote I/O station communication

The remote I/O station is a remote station that handles bit data only.

The ON/OFF information of a switch or indicator lamp is sent or received using the remote input RX and remote output RY (refer to  Page 110, Section 8.1.1).

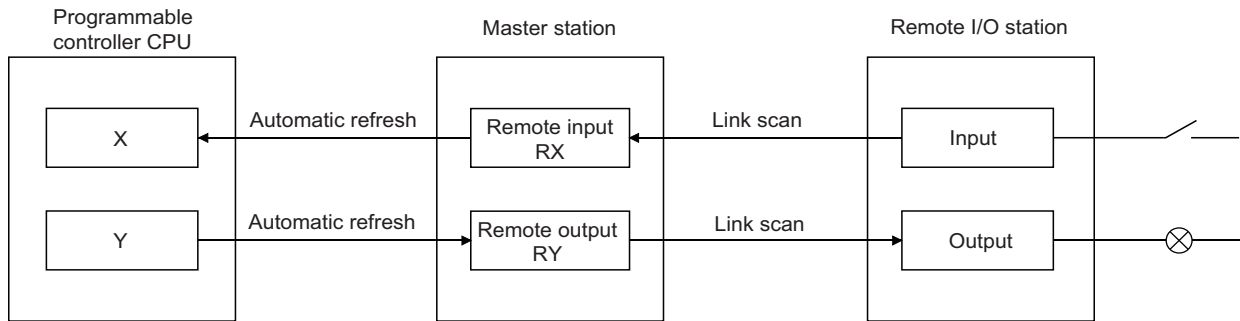

## (2) Remote device station communication

The remote device station is a remote station that handles bit and word data.

Signals for handshaking with the remote device station (initial request, error occurred flag, etc.) are communicated using the remote input RX and remote output RY.

The setting data to the remote device station are communicated using remote registers RWw and RWr (refer to  Page 113, Section 8.1.2).

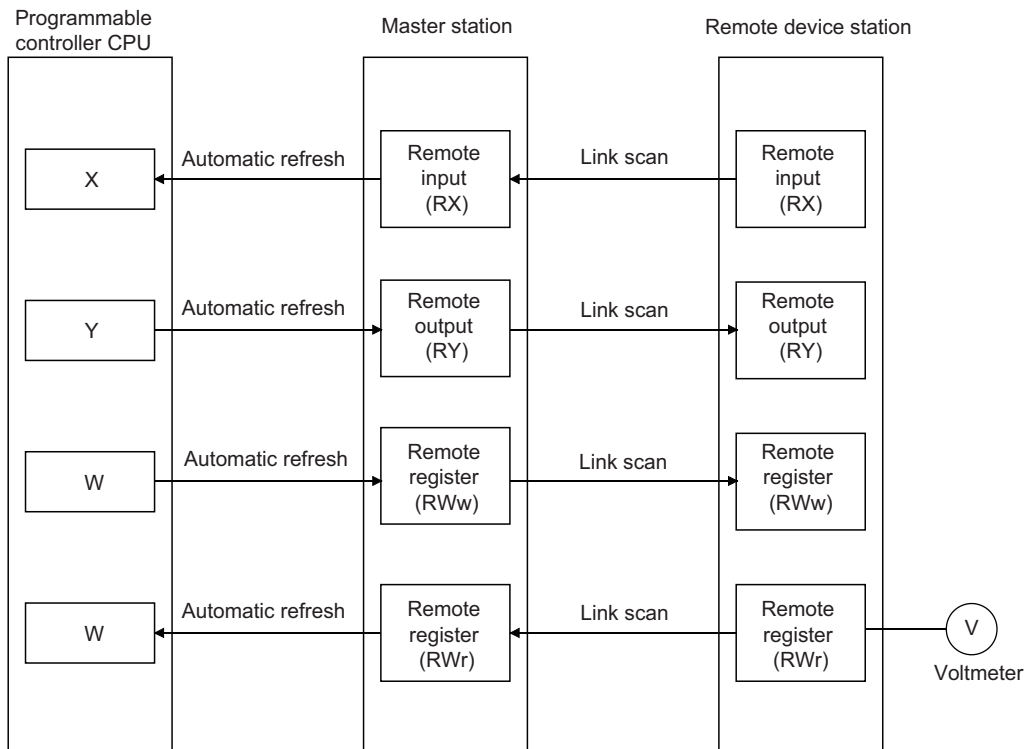

### (3) Local station communication

The local station is a station having a programmable controller CPU and the ability to communicate with the master and other local stations.

Communication between a master station and a local station uses two types of transmission methods: cyclic transmission and transient transmission (refer to  Page 118, Section 8.1.3).

#### (a) Cyclic transmission

Data communication between programmable controller CPUs can be performed in N:N mode using bit data (remote input RX and remote output RY) and word data (remote registers RWw and RWr).

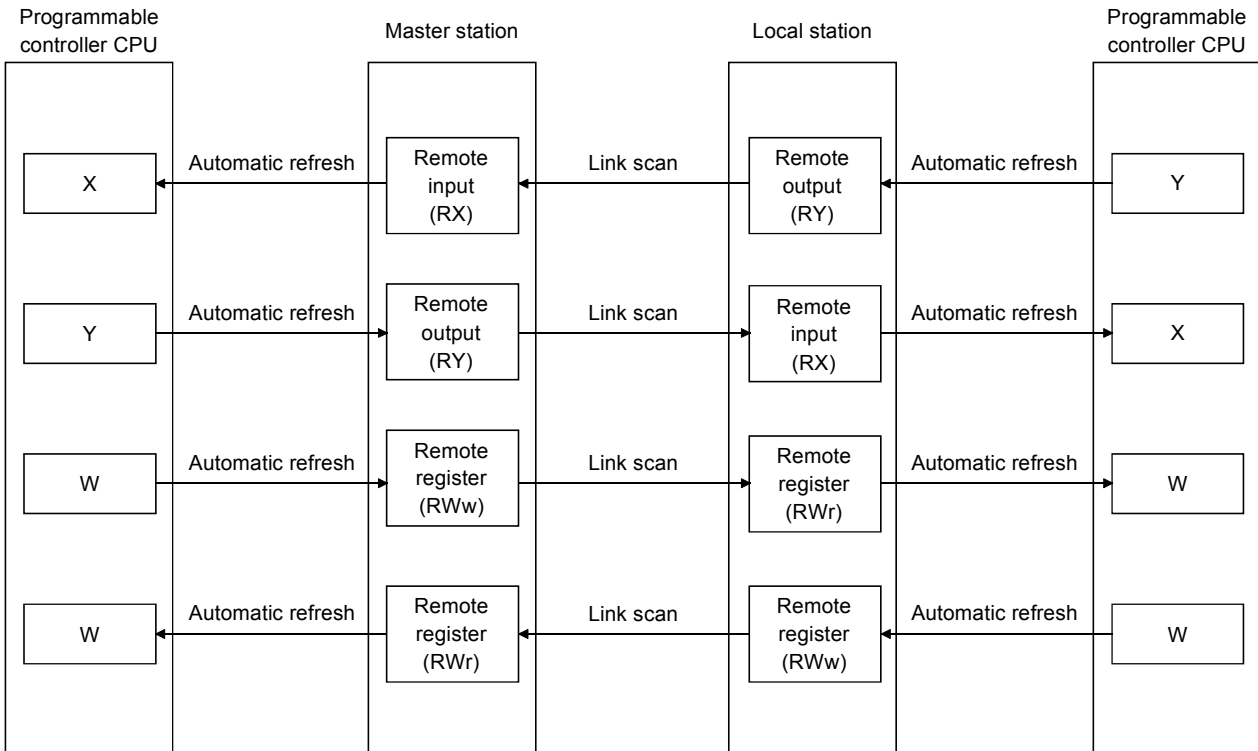

#### (b) Transient transmission

Read (G(P).RIRD) or write (G(P).RIWT) operation of the local station buffer memory and CPU device can be performed at any timing.

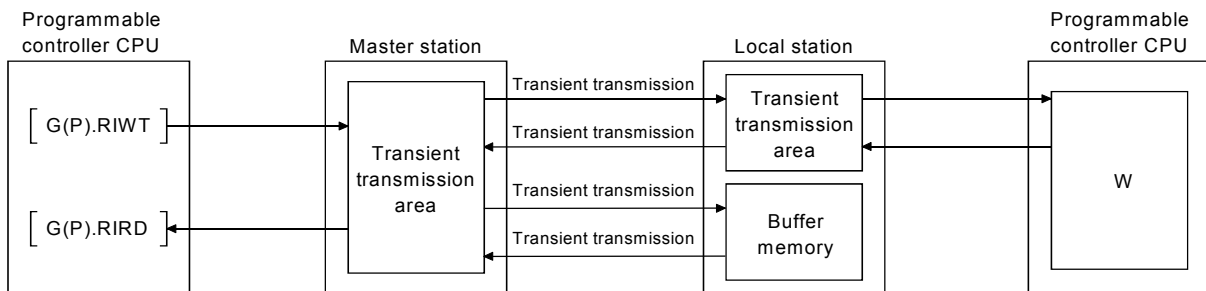

### (4) Intelligent device station communication

The intelligent device station is a station that can handle bit and word data.

Communication between a master station and an intelligent device station uses two types of transmission methods: cyclic transmission and transient transmission (refer to  Page 124, Section 8.1.4).

#### (a) Cyclic transmission

Signals for handshaking with the intelligent device station (positioning start, positioning complete, etc.) are communicated using the remote input RX and remote output RY.

Numeric data (positioning start number, present feed value, etc.) is communicated using remote registers RWw and RWr.

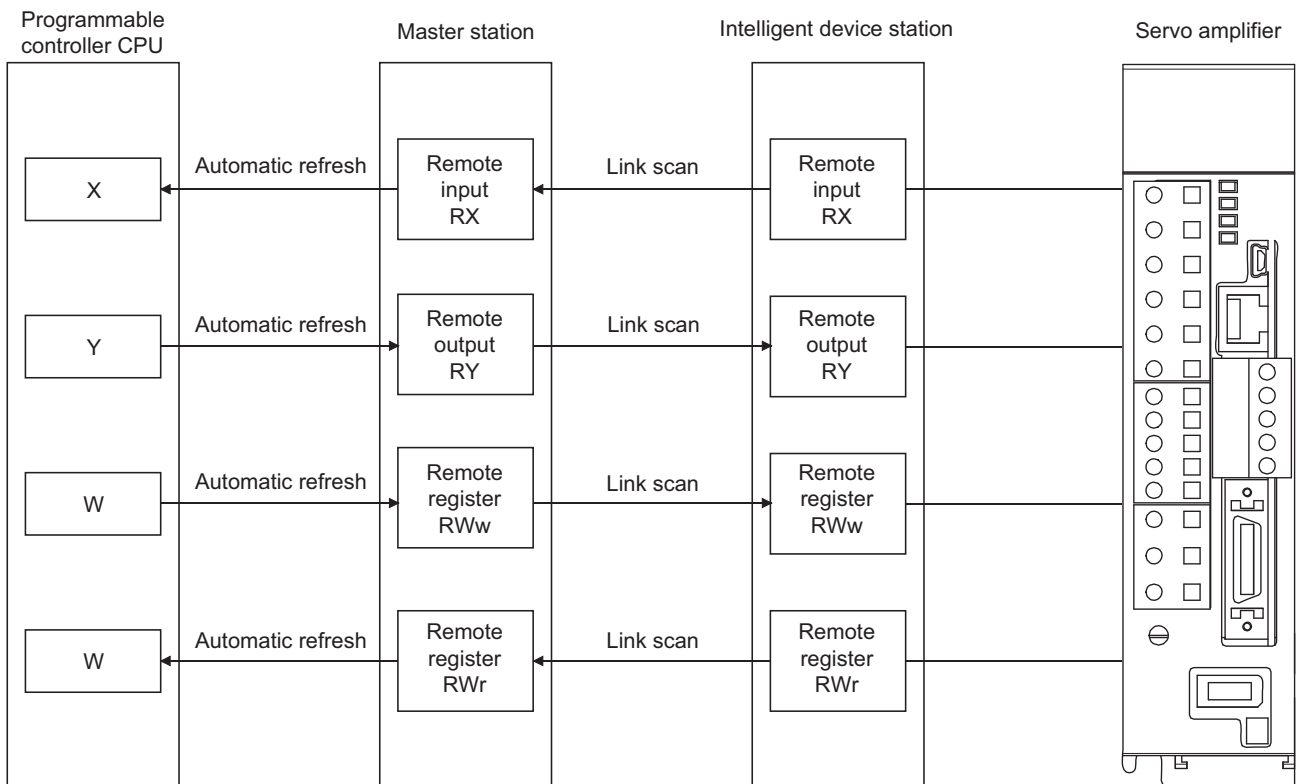

#### (b) Transient transmission

Reading (G(P).RIRD) or writing (G(P).RIWT) of buffer memory data in an intelligent device station is available at any timing.

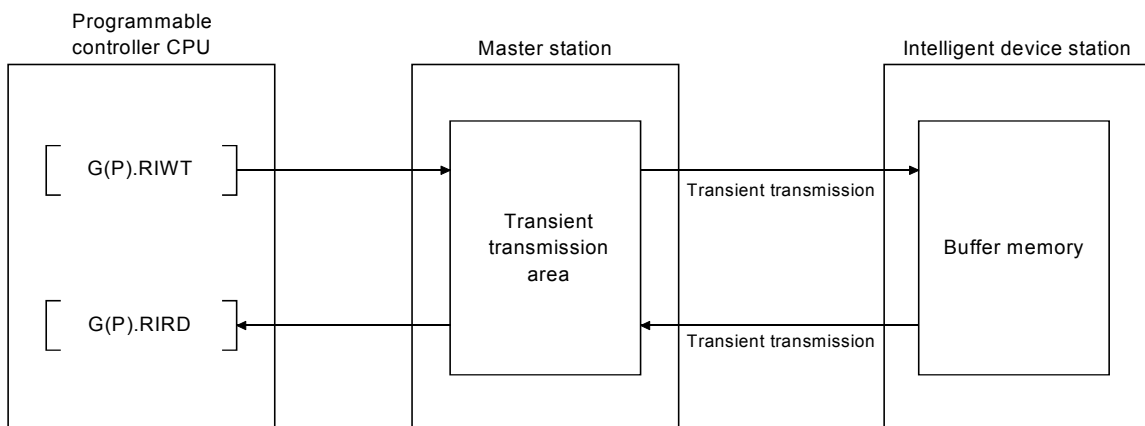

# CHAPTER 2 PART NAMES

The following describes the parts names of the L series master/local modules.

## (1) L26CPU-BT, L26CPU-PBT

For parts other than those for the built-in CC-Link functions, refer to the following manual.

 MELSEC-L CPU Module User's Manual (Hardware Design, Maintenance and Inspection)

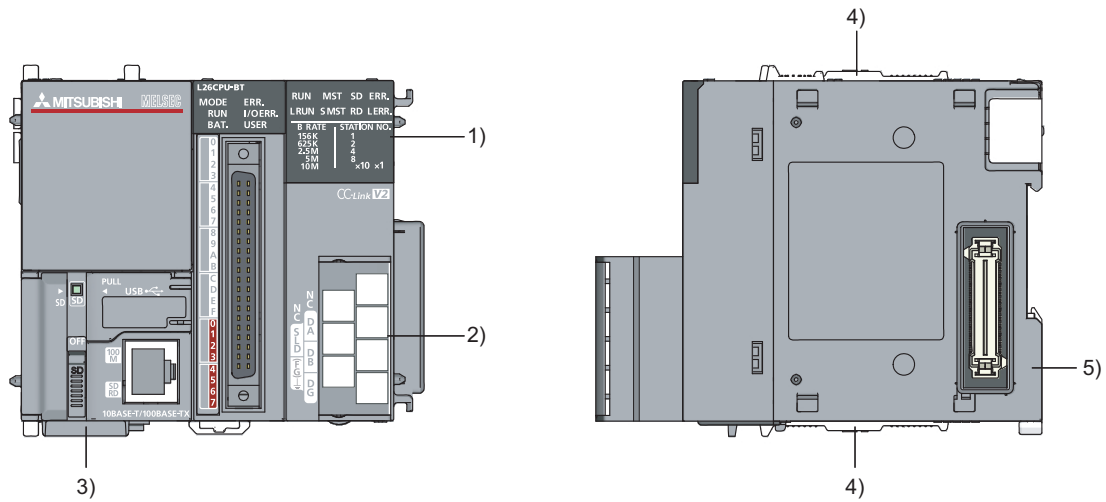

## (2) LJ61BT11

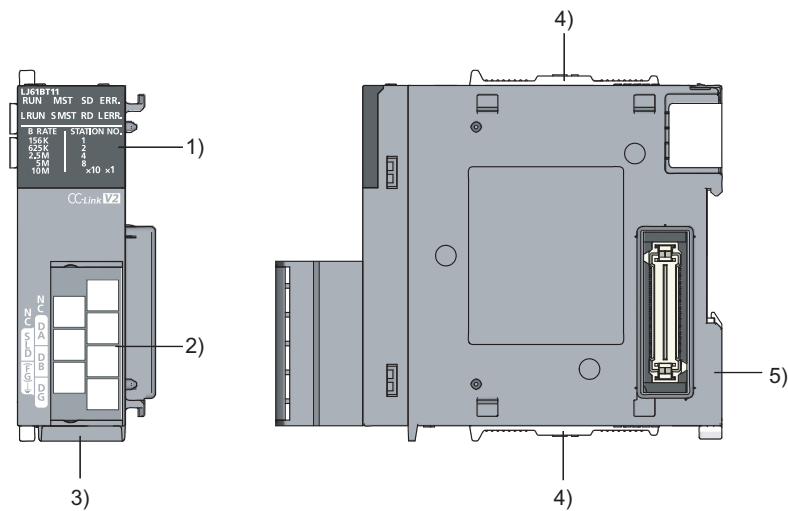



Number	Name	Description	
1)	LED indicators	The data link status can be checked with each ON/OFF status.	
		LED name	Description
		RUN	On : Operating normally Off : Hardware error or watchdog timer error
		L RUN	On: Data link is being executed
		MST	On: Operating as a master station. (in data link control)
		S MST	On: Operating as a standby master station. (in standby status)
		SD	On: Data being sent
		RD	On: Data being received
		ERR.	On: All stations have a communication error This LED also turns on when the following errors occur. <ul style="list-style-type: none"> <li>• There are more than one master station on the same line.</li> <li>• There is an error in the parameter settings.</li> <li>• The data link monitoring timer was activated.</li> <li>• The cable is disconnected.</li> <li>• The transmission path is affected by noise.</li> </ul> To check the source of the error, refer to  Page 358, Section 15.3. Or, refer to  Page 416, Appendix 3.2 for details on SW0058 (detailed LED display status). Flashing: A communication error station identified, or remote station No. duplicated.
		L ERR.	On: Communication error (host) Flashing: The terminating resistor is not attached. The module or CC-Link Ver.1.10 compatible cable is affected by noise.
B RATE	On: Operating at the indicated transmission speed. All off: Transmission speed auto-tracking (When succeeded, the LED of the followed transmission speed turns on.)		
STATION NO.	The module station number setting is indicated. <Range> Master station: 0 (All off) Local station and standby master station : 1 to 64  (Example) When the station number 15 is indicated  		

RUN	MST	SD	ERR.
LRUN	SMST	RD	LERR.
B RATE	STATION NO.		
156K	1		
625K	2		
2.5M	4		
5M	8		
10M	x10	x1	

Station type and ON/OFF status of the "MST" and "S MST" LEDs

Operating status					
Operating as a master station (data link control)			Operating as a standby master station (standby)		
Master station	Standby master station	Local station	Master station	Standby master station	Local station
MST ■	MST ■	MST □	MST □	MST □	MST □
S MST □	S MST □	S MST □	S MST ■	S MST ■	S MST □

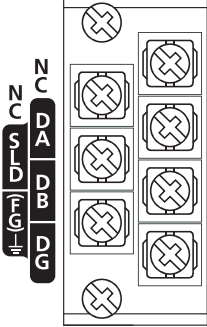
■ : On, □ : Off

Number	Name	Description
2)	Terminal block 	<p>A CC-Link dedicated Ver.1.10 compatible cable is connected for data linking.            For the connection method, refer to  Page 62, Section 6.3.</p> <p>Terminals SLD and FG are connected inside the module.            Since a 2-piece type terminal block is used, the module can be replaced without disconnecting the signal lines to the terminal block.            (Shut off the external power supply for the system in all phases before replacing the module.)</p>
3)	Serial No. display part	Displays the serial No. of the rating plate.
4)	Module joint lever	Fixes the connected modules.
5)	DIN rail hook	Used to install the module to the DIN rail.

# CHAPTER 3 SPECIFICATIONS

---

This chapter provides the specifications of the L series master/local modules.



## 3.1 General Specifications

---

For the general specifications of the L series master/local modules, refer to the following manual.  
"Safety Guidelines", the manual supplied with the CPU module or head module

## 3.2 Performance Specifications

The following shows the performance specifications of the L series master/local module.

Item	Specification	
	Built-in CC-Link function	LJ61BT11
Transmission speed	Can be selected from 156 kbps/ 625 kbps/ 2.5 Mbps/ 5 Mbps/ 10 Mbps	
Maximum overall cable distance (Maximum transmission distance)	Varies according to the transmission speed (Refer to  Page 30, Section 3.2.2)	
Maximum number of connected stations (master station)	64 (Refer to  Page 28, Section 3.2.1)	
Number of occupied stations (local station)	1 to 4 stations The number of stations can be switched by GX Works2 parameter setting.	
Maximum number of link points per system*1	Remote I/O (RX, RY): 2048 points Remote register (RWw): 256 points (master station → remote device station/local station/intelligent device station/standby master station) Remote register (RWr): 256 points (remote device station/local station/intelligent device station/standby master station → master station)	
Number of link points per station (remote station/local station/intelligent device station/standby master station)*1	Remote I/O (RX, RY): 32 points (local station is 30 points) Remote register (RWw): 4 points (master station → remote device station/local station/intelligent device station/standby master station) Remote register (RWr): 4 points (remote device station/local station/intelligent device station/standby master station → master station)	
Communication method	Broadcast polling method	
Synchronous method	Frame synchronization method	
Encoding method	NRZI method	
Transmission path	Bus (RS-485)	
Transmission format	Conforms to HDLC	
Error control system	CRC ( $X^{16} + X^{12} + X^5 + 1$ )	
Connection cable	Ver.1.10 compatible CC-Link dedicated cable	
RAS function	<ul style="list-style-type: none"> <li>• Automatic return function</li> <li>• Slave station cut-off function</li> <li>• Error detection by the link special relay/register</li> </ul>	
Number of occupied I/O points	32 points (I/O assignment: Intelligent 32 points)	
5V DC internal current consumption	*2	0.46A
Weight	*2	0.15kg

\*1 Indicates the number of link points in remote net ver.1 mode.

For the number of link points in remote net Ver.2 mode and remote net additional mode, refer to  Page 27, Section 3.2 (1).

\*2 For the 5V DC internal current consumption and weight, refer to the following manual.

 MELSEC-L CPU Module User's Manual (Hardware Design, Maintenance and Inspection)



**(1) Number of link points in remote net ver.2 mode or remote net additional mode****(a) Maximum number of link points per system**

Item	Number of link points
Remote I/O (RX/Ry)	8192 points
Remote register (RWw)	2048 points (master station → remote device station/local station/ intelligent device station/standby master station)
Remote register (RWr)	2048 points (remote device station/local station/ intelligent device station/standby master station → master station)

**(b) Number of link points per station**

Item	Number of link points			
	Expanded cyclic setting			
	Single	Double	Quadruple	Octuple
Remote I/O (RX/Ry)	32 points (30 points for a local station)	32 points (30 points for a local station)	64 points (62 points for a local station)	128 points (126 points for a local station)
Remote register (RWw)	4 points	8 points	16 points	32 points
Remote register (RWr)	4 points	8 points	16 points	32 points

**(c) Number of link points per number of occupied stations**

Item		Specifications			
		Expanded cyclic setting			
		Single	Double	Quadruple	Octuple
1 station occupied	Remote I/O (RX/Ry)	32 points (30 points for a local station)	32 points (30 points for a local station)	64 points (62 points for a local station)	128 points (126 points for a local station)
	Remote register (RWw)	4 points	8 points	16 points	32 points
	Remote register (RWr)	4 points	8 points	16 points	32 points
2 stations occupied	Remote I/O (RX/Ry)	64 points (62 points for a local station)	96 points (94 points for a local station)	192 points (190 points for a local station)	384 points (382 points for a local station)
	Remote register (RWw)	8 points	16 points	32 points	64 points
	Remote register (RWr)	8 points	16 points	32 points	64 points
3 stations occupied	Remote I/O (RX/Ry)	96 points (94 points for a local station)	160 points (158 points for a local station)	320 points (318 points for a local station)	640 points (638 points for a local station)
	Remote register (RWw)	12 points	24 points	48 points	96 points
	Remote register (RWr)	12 points	24 points	48 points	96 points
4 stations occupied	Remote I/O (RX/Ry)	128 points (126 points for a local station)	224 points (222 points for a local station)	448 points (446 points for a local station)	896 points (894 points for a local station)
	Remote register (RWw)	16 points	32 points	64 points	128 points
	Remote register (RWr)	16 points	32 points	64 points	128 points

## 3.2.1 Maximum number of connected stations

A CC-Link system can be configured with the number of modules meeting the following conditions.

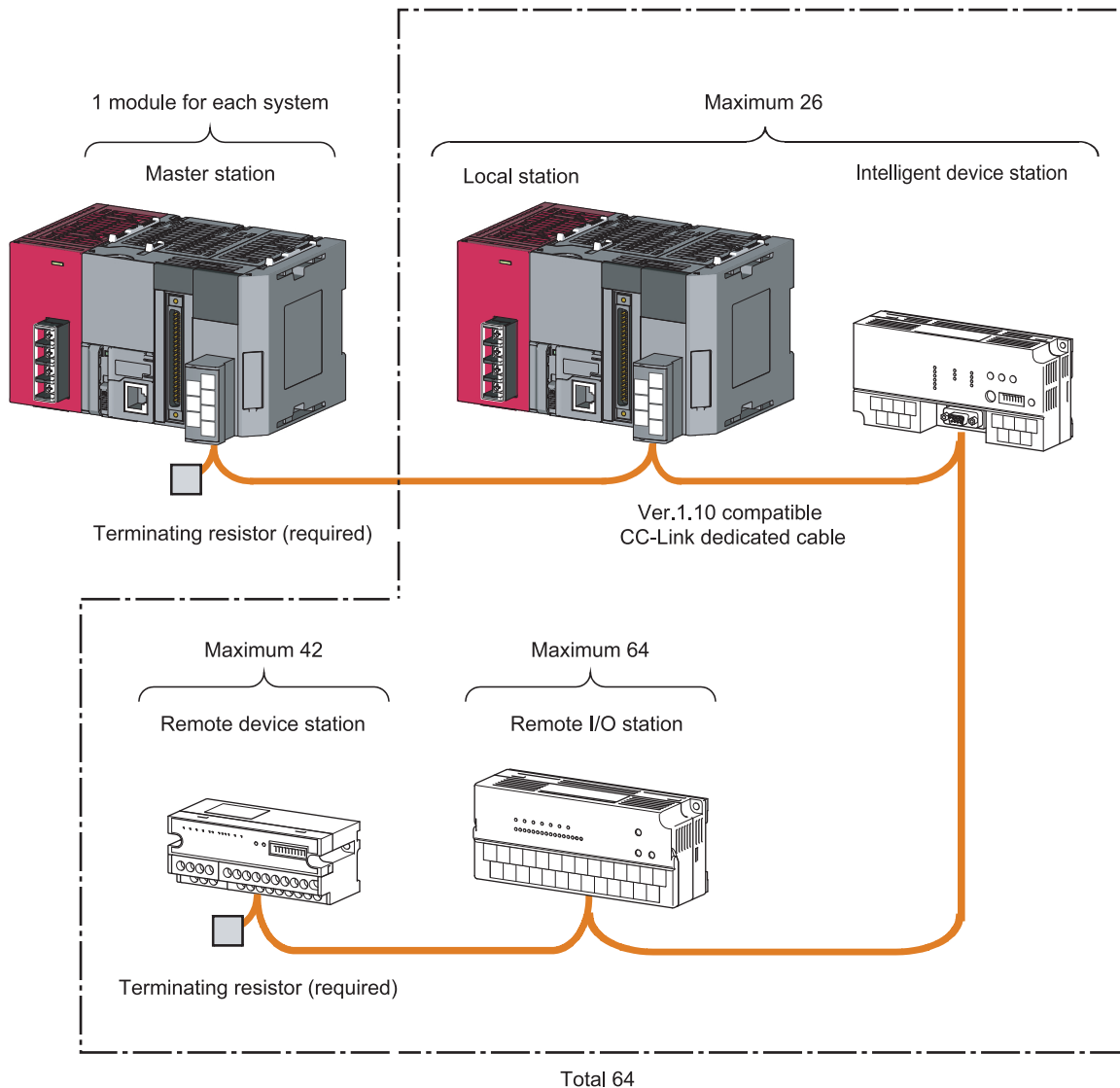

### (1) Remote net ver.1 mode

A total of 64 slave stations can be connected to a single master station.  
However, the following conditions must all be satisfied.

Condition 1	$\{(1 \times a) + (2 \times b) + (3 \times c) + (4 \times d)\} \leq 64$	a: Number of modules occupying 1 station b: Number of modules occupying 2 stations c: Number of modules occupying 3 stations d: Number of modules occupying 4 stations
Condition 2	$\{(16 \times A) + (54 \times B) + (88 \times C)\} \leq 2304$	A: Number of remote I/O stations $\leq 64$ B: Number of remote device stations $\leq 42$ C: Number of local stations, standby master stations and intelligent device stations $\leq 26$

**(2) Remote net ver.2 mode, remote net additional mode**

A total of 64 slave stations can be connected to a single master station.

However, the following conditions must all be satisfied.

Condition 1	$\{(a + a2 + a4 + a8) + (b + b2 + b4 + b8) \times 2 + (c + c2 + c4 + c8) \times 3 + (d + d2 + d4 + d8) \times 4\} \leq 64$	<p>a: The total number of ver.1 compatible slave stations that occupy 1 station, and ver.2 compatible slave stations that occupy 1 station which are set to "Single".</p> <p>b: The total number of ver.1 compatible slave stations that occupy 2 stations, and ver.2 compatible slave stations that occupy 2 stations which are set to "Single".</p> <p>c: The total number of ver.1 compatible slave stations that occupy 3 stations, and ver.2 compatible slave stations that occupy 3 stations which are set to "Single".</p> <p>d: The total number of ver.1 compatible slave stations that occupy 4 stations, and ver.2 compatible slave stations that occupy 4 stations which are set to "Single".</p>
Condition 2	$\{[(a \times 32) + (a2 \times 32) + (a4 \times 64) + (a8 \times 128)] + [(b \times 64) + (b2 \times 96) + (b4 \times 192) + (b8 \times 384)] + [(c \times 96) + (c2 \times 160) + (c4 \times 320) + (c8 \times 640)] + [(d \times 128) + (d2 \times 224) + (d4 \times 448) + (d8 \times 896)]\} \leq 8192$	<p>a2: The number of ver.2 compatible stations that occupy 1 station which are set to "Double".</p> <p>b2: The number of ver.2 compatible stations that occupy 2 stations which are set to "Double".</p> <p>c2: The number of ver.2 compatible stations that occupy 3 stations which are set to "Double".</p> <p>d2: The number of ver.2 compatible stations that occupy 4 stations which are set to "Double".</p>
Condition 3	$\{[(a \times 4) + (a2 \times 8) + (a4 \times 16) + (a8 \times 32)] + [(b \times 8) + (b2 \times 16) + (b4 \times 32) + (b8 \times 64)] + [(c \times 12) + (c2 \times 24) + (c4 \times 48) + (c8 \times 96)] + [(d \times 16) + (d2 \times 32) + (d4 \times 64) + (d8 \times 128)]\} \leq 2048$	<p>a4: The number of ver.2 compatible stations that occupy 1 station which are set to "Quadruple".</p> <p>b4: The number of ver.2 compatible stations that occupy 2 stations which are set to "Quadruple".</p> <p>c4: The number of ver.2 compatible stations that occupy 3 stations which are set to "Quadruple".</p> <p>d4: The number of ver.2 compatible stations that occupy 4 stations which are set to "Quadruple".</p> <p>a8: The number of ver.2 compatible stations that occupy 1 station which are set to "Octuple".</p> <p>b8: The number of ver.2 compatible stations that occupy 2 stations which are set to "Octuple".</p> <p>c8: The number of ver.2 compatible stations that occupy 3 stations which are set to "Octuple".</p> <p>d8: The number of ver.2 compatible stations that occupy 4 stations which are set to "Octuple".</p>
Condition 4	$\{(16 \times A) + (54 \times B) + (88 \times C)\} \leq 2304$	<p>A: Number of remote I/O stations <math>\leq 64</math></p> <p>B: Number of remote device stations <math>\leq 42</math></p> <p>C: Number of local stations, standby master stations and intelligent device stations <math>\leq 26</math></p>

## 3.2.2 Maximum overall cable distance

The relation of the transmission speed and maximum overall cable distance when configuring the entire system with products compatible with CC-Link Ver.1.10 or higher and Ver.1.10 compatible CC-Link dedicated cables is shown below.

For the identification of the CC-Link Version, refer to the installation manual issued by the CC-Link Partner Association.

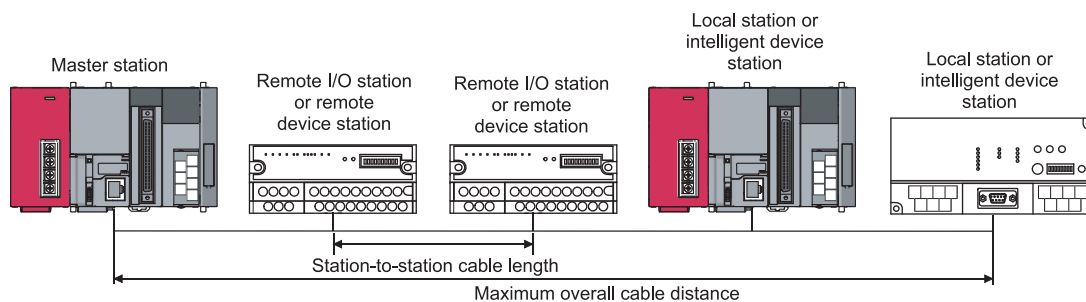

Version 1.10 compatible CC-Link dedicated cable (terminating resistor of 110Ω used)

Transmission speed	Station-to-station cable length	Maximum overall cable distance
156kbps	20cm or longer	1200m
625kbps		900m
2.5Mbps		400m
5Mbps		160m
10Mbps		100m

### 3.2.3 Ver.1.10 compatible CC-Link dedicated cable

---

Use Ver.1.10 compatible CC-Link dedicated cables for the CC-Link system.

If a cable other than the Ver.1.10 compatible CC-Link dedicated cable is used, the performance of the CC-Link system cannot be guaranteed.

For the specifications of the Ver.1.10 compatible CC-Link dedicated cables or any other inquiries, visit the following website:

Website of CC-Link Partner Association: [www.cc-link.org](http://www.cc-link.org)

**Remark**

For details, refer to the CC-Link Cable Wiring Manual issued by CC-Link Partner Association.

## 3.3 Function List

The following shows the function list of the L series master/local module.



### (1) List of the "basic functions"

Item	Description	Reference
Communication with remote I/O stations	Performs on/off data communication with remote I/O stations.	Page 110, Section 8.1.1
Communication with remote device stations	Performs on/off data and numeric data communication with remote device stations.	Page 113, Section 8.1.2
Communication with local stations	Performs on/off data and numeric data communication with local stations.	Page 118, Section 8.1.3
Communication with intelligent device stations	Performs communication with intelligent device station, by cyclic transmission, and transient transmissions.	Page 124, Section 8.1.4

### (2) List of the "functions for improving system reliability"

Item	Description	Reference
Slave station cut-off function	Disconnects a slave station that cannot continue the data link due to a reason such as power off, so that data link can continue among normal slave stations only.	Page 130, Section 8.2.1
Automatic return function	When a slave station, which has been disconnected from the network due to a reason such as power off, returns to the normal status, it automatically joins the data link.	Page 131, Section 8.2.2
Data link status setting when the master station programmable controller CPU has an error	Sets whether to stop or continue the data link when an error that stops the operation occurs at the master station programmable controller CPU in the system that has no standby master station. When "Continue" is set, the diagnostics of the master station can be performed from local stations.	Page 132, Section 8.2.3
Setting the status of input data from a data link faulty station	Sets whether to clear or hold the input data (remote input RX) from a station that detected a data link error due to a reason such as power off.	Page 133, Section 8.2.4
Slave station refresh/compulsory clear setting in case of programmable controller CPU STOP	Sets whether to refresh or forcibly clear output data (remote output RY) to the slave stations when the programmable controller CPU comes to STOP. When "Clears Compulsorily" is set, the remote output RY turns off when the operation stops due to STOP of programmable controller CPU or due to an error occurrence.	Page 134, Section 8.2.5
Standby master function	Continues the data link by switching the control to the standby master station when a problem occurs in the master station.	Page 140, Section 8.2.7
Data link start by standby master station	Starts data link when either of the master or standby master station is turned on.	Page 156, Section 8.2.8
Block guarantee of cyclic data per station	Guarantees the consistency of the cyclic data for each slave station.	Page 159, Section 8.2.9
Guarantee of 32-bit data	Guarantees the 32-bit data of the remote register (RWr/RWw) between programmable controller CPU and the master/local station.	Page 164, Section 8.2.10

**(3) List of the "handy functions"**

Item	Description	Reference
Remote device station initialization procedure registration function	Programs for the initial setting become unnecessary, since the initial settings in the remote device station are set at the network parameter. The initial settings in the remote device station can be configured easily.	Page 165, Section 8.3.1
Event issuance for the interrupt program	Since the interrupt program of the programmable controller CPU is executed according to the established event issuance conditions, high speed data receive processing can be made without being influenced by the sequence scan.	Page 172, Section 8.3.2
Automatic CC-Link startup	The CC-Link starts automatically, only by turning the power on, and the operation at the system construction can be checked.	Page 176, Section 8.3.3
Reserved station function	By setting slave stations that will be connected in the future as reserved stations, they will not be treated as data link faulty stations.	Page 178, Section 8.3.4
Error invalid station setting function	Prevents slave stations that may be powered off in the system configuration from being treated as data link faulty stations by setting the network parameters.	Page 179, Section 8.3.5
Temporary error invalid station setting function	Changes slave stations without detecting errors during online operation. Also, prevents slave stations, which are turned off in the system configuration, from being treated as data link faulty stations temporarily.	Page 180, Section 8.3.6
Scan synchronous function	Selects whether to synchronize or not the link scan with sequence scan. In the synchronous mode, the link scan is performed synchronously with the sequence scan. Therefore, the output data can be sent in high speed. In the asynchronous mode, the link scan is performed not synchronized to the sequence scan. Therefore, a high speed link scan can be performed independent of the sequence scan.	Page 182, Section 8.3.7
Data link stop/restart	Stops or restarts the data link that is being executed. By stopping the data link, the program debug can be performed efficiently, since data from other stations are not received, and data are not sent from the host station.	Page 186, Section 8.3.8
Remote I/O station points setting	Allows the I/O points of the remote I/O stations to be selected from among 8 points, 16 points and 32 points, reducing the number of reserved points. The refresh device points of the programmable controller CPU and the link refresh time can be saved.	Page 188, Section 8.3.9
Master station duplication error cancel function	Master station duplication errors can be canceled without turning the power supply off to on, or without resetting the programmable controller CPU.	Page 190, Section 8.3.10
Transmission speed auto-tracking setting	When the host station is a local station or a standby master station, an auto-tracking occurs according to the transmission speed of the master station, what eliminates setting errors of the transmission speed.	Page 108, Section 7.5 (2)
Status logging	Logs the data link status of all stations. When multiple stations repeat normal/faulty, or when determined stations and later repeat normal/faulty, this function enables easy identification of the causes, such as contact failure of the cable, or the noise occurrence location.	Page 380, Section 15.4.3
Automatic detection of connected devices	The time of setting parameters can be reduced by automatically reading information of slave stations.	Page 83, Section 7.3.2 (2)
	The model names of slave stations can be read.	 iQ Sensor Solution Reference Manual
Data backup/restoration	The setting data of the slave station is backed up into the SD memory card of the CPU module on the master station. The setting data backed up into the SD memory card of the CPU module on the master station is restored into the slave module.	 iQ Sensor Solution Reference Manual

**(4) List of the "functions for transient transmission"**

<b>Item</b>	<b>Description</b>	<b>Reference</b>
Transient transmission	Specifies a target and communicates with it at any timing when required.	Page 191, Section 9.1



## 3.4 Mode Selection

There are two different CC-Link versions: Ver.1 and Ver.2, and the L series master/local modules are Ver.2-compatible modules.

The L series master/local modules have four types of modes for various systems.

### (1) Overview of the modes

CC-Link Ver.1/Ver.2	Mode	Connectable station type	Overview		Reference
Ver.1	Remote I/O net mode	Remote I/O station	Select this mode when the system consists of only the master station and remote I/O stations. Since the cyclic transmission speed is high, the link scan time can be reduced.		Page 35, Section 3.4 (1) (a)
	Remote net ver.1 mode	Remote I/O station Remote device station	Mode for complete compatibility with the conventional module (Ver.1 compatible station). Select this mode when the number of link points need not to be increased.		—
Ver.2	Remote net additional mode	Intelligent device station Local station Standby master station	Select this mode when the number of link points need to be increased.	Select this mode when adding a Ver.2 compatible slave station to the existing Ver.1 system.	Page 38, Section 3.4.1 (2)
	Remote net ver.2 mode			Select this mode when configuring a new system.	Page 37, Section 3.4.1 (1)

#### (a) Link scan time according to the mode (reference value)

Number of stations	Remote I/O net mode	Remote net ver.1 mode, Remote net additional mode, Remote net ver.2 mode
8	0.61ms	1.20ms
16	0.94ms	1.57ms
32	1.61ms	2.32ms
64	2.94ms	3.81ms

(Transmission speed: 10Mbps)

[Setting method]

Set "Mode" in the network parameter setting of GX Works2.

(Refer to  Page 77, Section 7.3.2 and Page 99, Section 7.4.2)

## (2) Mode selection flowchart

The following flowchart explains the points of mode selection.

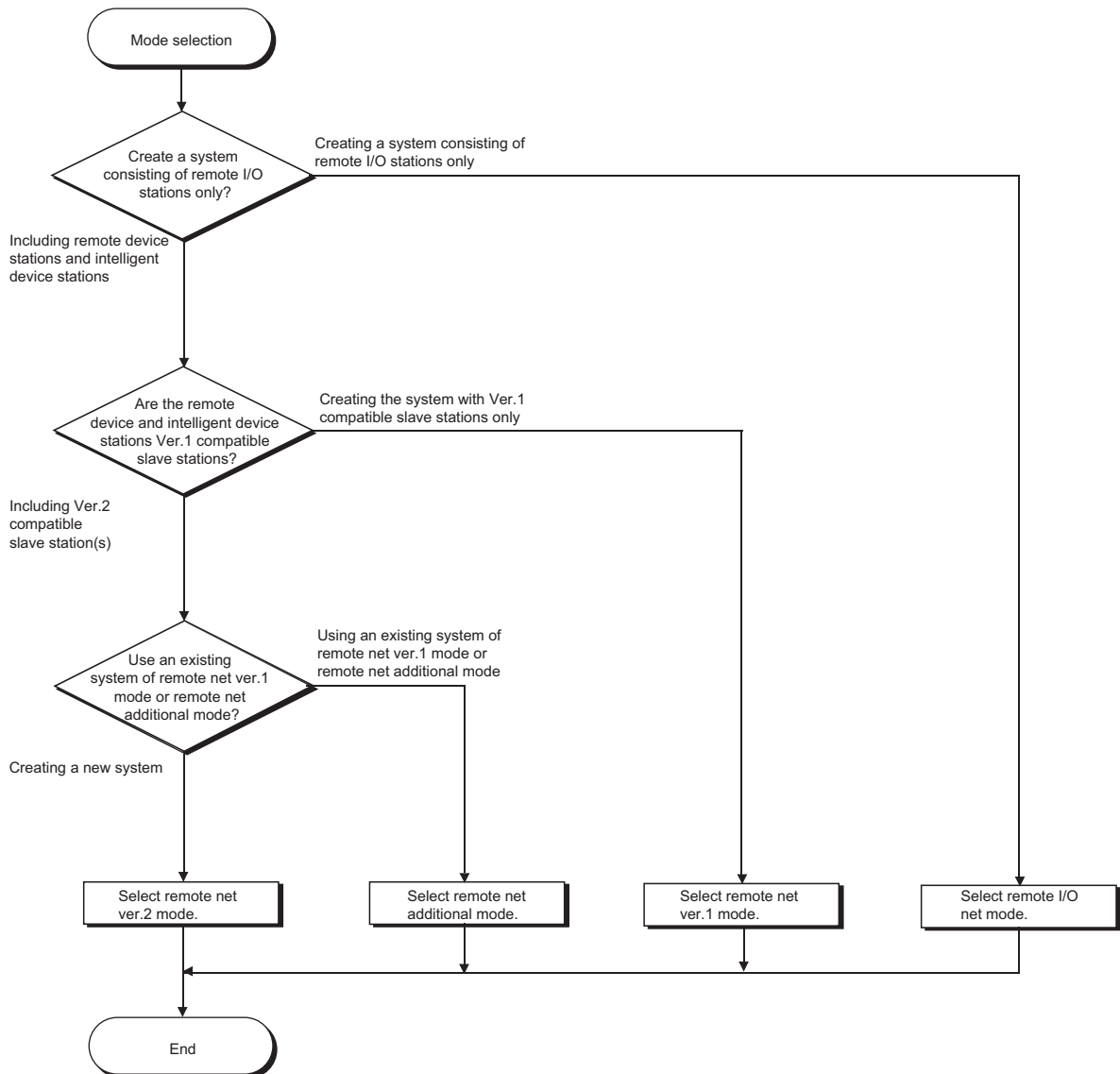

### 3.4.1 Expanded cyclic setting

When increasing the number of link points, select the remote net ver.2 mode or the remote net additional mode.

#### (1) Remote net ver.2 mode

This mode is designed to configure a new system.

The number of link points can be increased as indicated below.

- Per station, RX/RX can be increased to up to 128 points and RWw/RWr to up to 32 points.
- Per CC-Link network, RX/RX can be increased to up to 8192 points and RWw/RWr to up to 2048 points.

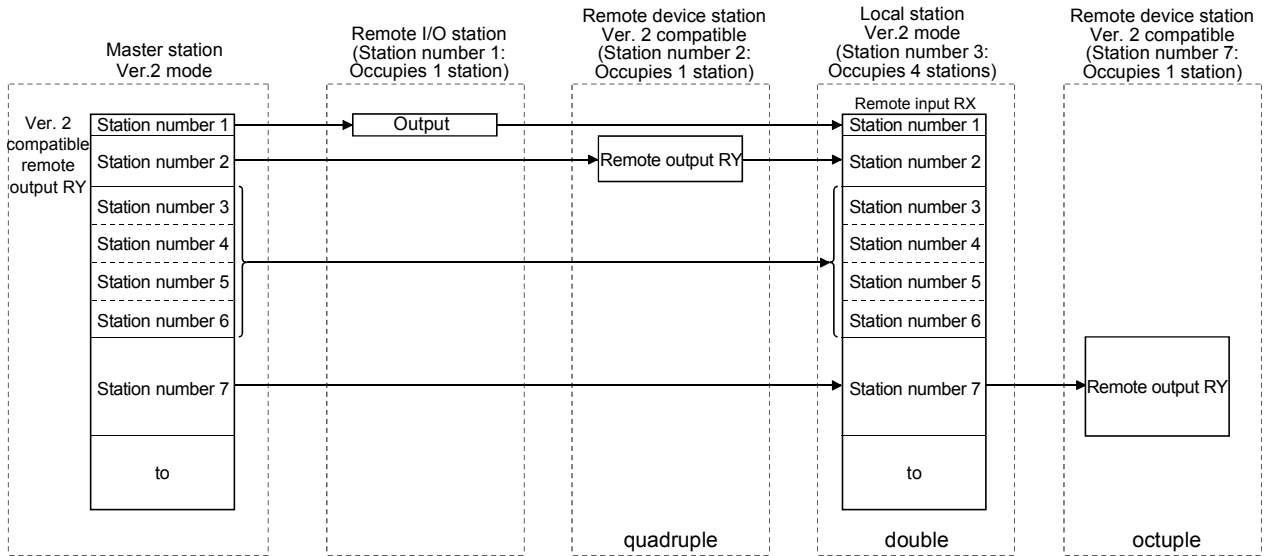

**Point**

- In the remote net ver.2 mode, the remote registers of the remote I/O station are set to 0 points.
- When the ver.2 compatible slave station is added or deleted, the refresh devices of the programmable controller CPU will vary by the number of points set to the added or deleted slave station in the slave stations of the station numbers after the added or deleted slave station. Confirm the varying number of points in Page 28, Section 3.2 (1).

## (2) Remote net additional mode

This mode is designed for use when slave stations including a ver.2 compatible station is added to the existing ver.1 system.

The program of the existing system can be used as is.

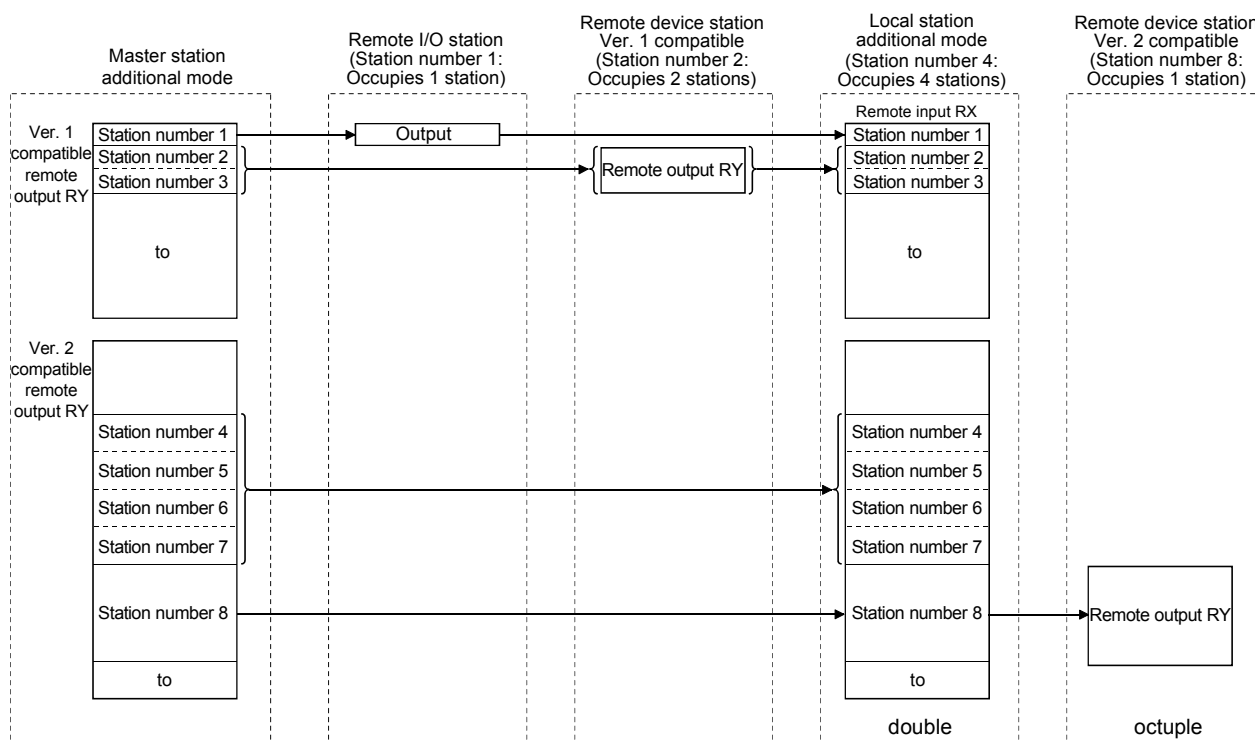

### Point

- Set the station numbers of the slave stations to be added after the last station number used in the existing system. \*1 In the above example, the slave stations are added to and after station No. 4 since the existing system uses up to station No. 3.
- When the ver.2 compatible slave station is added or deleted, the refresh devices of the programmable controller CPU will vary by the number of points set to the added or deleted slave station in the slave stations of the station numbers after the added or deleted slave station. Confirm the varying number of points in Page 28, Section 3.2 (1).
- In the remote net additional mode, the ver.2 compatible slave station must be placed in the latter half as described in \*1. When there is a possibility that ver.1 compatible slave stations will be added in the future in the remote net additional mode, set multiple reserved stations after the ver.1 compatible slave station to ensure ease of expanding the system.
- For the system that includes a standby master station, it is recommended to change for the remote net ver.2 mode. When the remote net additional mode is used, the program for the standby master station must be corrected.

### (3) Mode combination

#### (a) Whether system can be configured or not

The following tables indicate whether cyclic transmission can be made or not in each station.

Master station		Slave station							
		L series master/local module, QJ61BT11N, Q81BD-J61BT11, Q80BD-J61BT11N						A1SJ61BT11 <sup>*3</sup> , A1SJ61QBT11 <sup>*3</sup>	
		Local station			Standby master station			Local station	Standby master station
		Ver.2 mode	Additional mode	Ver.1 mode	Ver. 2 mode	Additional mode	Ver.1 mode	Ver.1 mode	Ver.1 mode
L series master/local module	Ver.2 mode	○	×	△ <sup>*1</sup>	○	×	×	△ <sup>*1</sup>	×
	Additional mode	○ <sup>*2</sup>	○	△ <sup>*1</sup>	×	○	×	△ <sup>*1</sup>	×
	Ver.1 mode	×	×	○	×	×	○	○	○

Master station		Slave station				
		Intelligent device station		Remote station <sup>*4</sup>		
				Remote device station		Remote I/O station
		Ver.2 compatible	Ver.1 compatible	Ver.2 compatible	Ver.1 compatible	Ver.1 compatible
L series master/local module	Ver.2 mode	○	○	○	○	○
	Additional mode	○	○	○	○	○
	Ver.1 mode	×	○	×	○	○

○: Cyclic transmission enabled, △: Cyclic transmission enabled on condition, ×: Cyclic transmission disabled

\*1 Although a local station in the remote net Ver.1 mode cannot perform data link with a Ver.2-compatible slave station, the status of the Ver.2-compatible slave station is stored in Other station data link status (SW0080 to SW0083) for the local station as well as that for the master station. (When the master station is normally performing data link with the Ver.2-compatible slave station, Other station data link status (SW0080 to SW0083) for the local station indicates "0: Normal".) Note that cyclic data in the Ver.2-compatible slave station will become "0" in the local station in the remote net Ver.1 mode.

Transient transmission cannot be performed due to an error such as a timeout error.

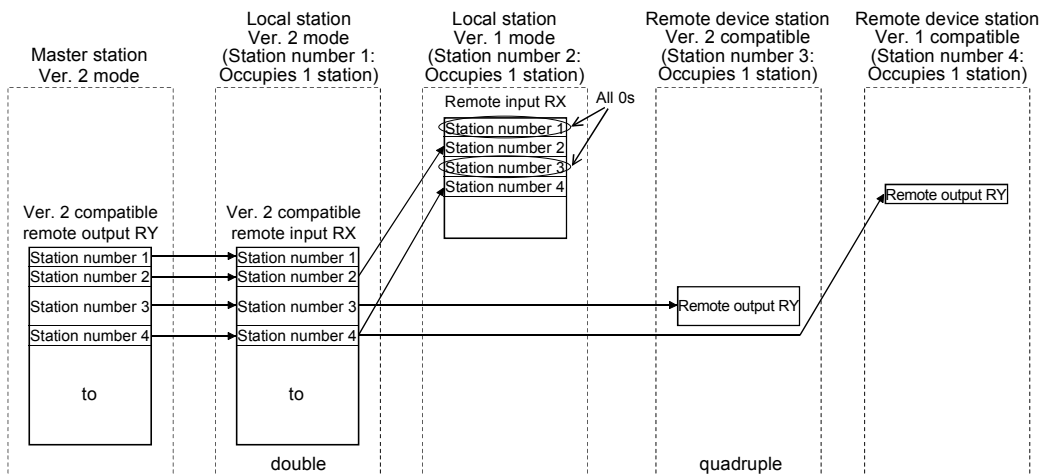

\*2 A link is performed as shown in the following areas.

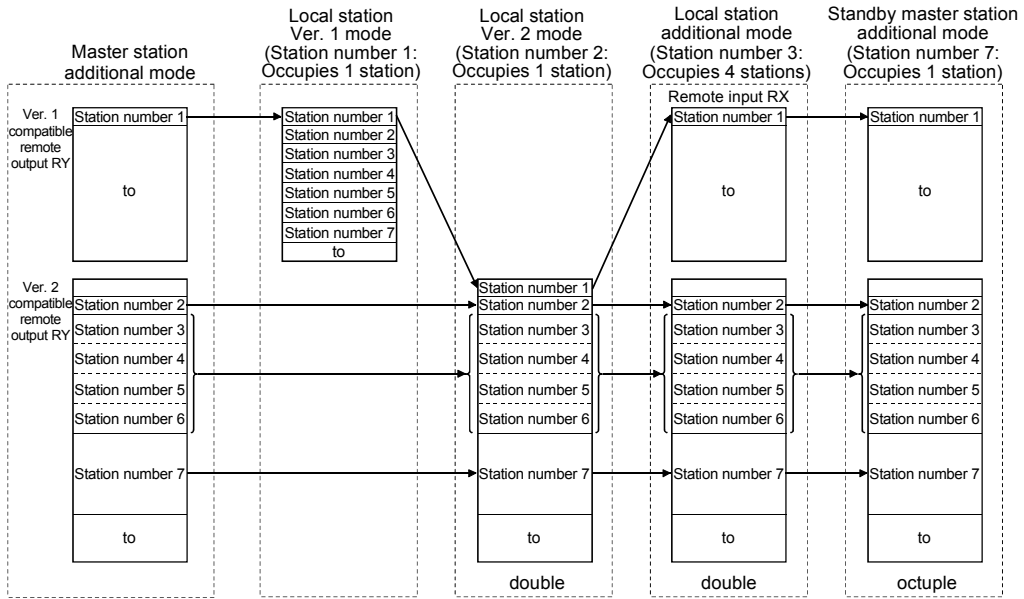

\*3 The remote net ver.2 mode and remote net additional mode cannot be used with the QJ61BT11.

\*4 Data link is not available when the version set in the station type of the master station information is different from that of the remote station. For example, when the station type of the master station information is set as "Ver.1 remote device station" although the actual remote device station is set to "Ver.2 remote device station", data link cannot be performed with the "ERR." LED on the master station flashing and the "L RUN" LED on the remote device station turned OFF.

**(b) Whether send/receive is enabled or not**

- Cyclic transmission

The following table indicates whether send/receive of cyclic data is enabled or not.

Send station				Receive station					
				L series master/local module, QJ61BT11N					
				Master station					
				Ver. 2 mode		Additional mode		Ver.1 mode	
				Ver.2 compatible area	Ver.1 compatible area	Ver.2 compatible area	Ver.1 compatible area	Ver.2 compatible area	Ver.1 compatible area
L series master/local module, QJ61BT11N	Master station	Ver.2 mode	Ver.2 compatible area	—	—	—	—	—	—
			Ver.1 compatible area	—	—	—	—	—	—
		Additional mode	Ver.2 compatible area	—	—	—	—	—	—
			Ver.1 compatible area	—	—	—	—	—	—
		Ver.1 mode	Ver.2 compatible area	—	—	—	—	—	—
			Ver.1 compatible area	—	—	—	—	—	—
	Local station	Ver.2 mode	Ver.2 compatible area	○	—	○	×	—	×
			Ver.1 compatible area	—	—	—	—	—	—
		Additional mode	Ver.2 compatible area	—	—	○	×	—	—
			Ver.1 compatible area	—	—	—	—	—	—
		Ver.1 mode	Ver.2 compatible area	—	—	—	—	—	—
			Ver.1 compatible area	○	—	×	○	—	○
		Intelligent device station	Ver.2 compatible	○	—	○	×	—	×
			Ver.1 compatible	○	—	×	○	—	○
Remote device station	Ver.2 compatible	○	—	○	×	—	×		
	Ver.1 compatible	○	—	×	○	—	○		
Remote I/O station	Ver.1 compatible	○	—	×	○	—	○		

○: Cyclic transmission enabled, ×: Cyclic transmission disabled, —: Prohibited

Send station				Receive station					
				L series master/local module, QJ61BT11N					
				Local station					
				Ver. 2 mode		Additional mode		Ver.1 mode	
				Ver.2 compatible area	Ver.1 compatible area	Ver.2 compatible area	Ver.1 compatible area	Ver.2 compatible area	Ver.1 compatible area
L series master/local module, QJ61BT11N	Master station	Ver.2 mode	Ver.2 compatible area	○	—	—	—	—	○
			Ver.1 compatible area	—	—	—	—	—	—
		Additional mode	Ver.2 compatible area	○	—	○	×	—	—
			Ver.1 compatible area	○	—	×	○	—	○
		Ver.1 Mode	Ver.2 compatible area	—	—	—	—	—	—
			Ver.1 compatible area	×	—	—	—	—	○
	Local station	Ver.2 mode	Ver.2 compatible area	○	—	○	—	—	×
			Ver.1 compatible area	—	—	—	—	—	—
		Additional mode	Ver.2 compatible area	○	—	○	×	—	×
			Ver.1 compatible area	—	—	—	—	—	—
		Ver.1 mode	Ver.2 compatible area	—	—	—	—	—	—
			Ver.1 compatible area	○	—	×	○	—	○
		Intelligent device station	Ver.2 compatible	○	—	○	×	—	×
			Ver.1 compatible	○	—	×	○	—	○
Remote device station	Ver.2 compatible	○	—	○	×	—	×		
	Ver.1 compatible	○	—	×	○	—	○		
Remote I/O station	Ver.1 compatible	○	—	×	○	—	○		

○: Cyclic transmission enabled, ×: Cyclic transmission disabled, —: Prohibited



Send station				Receive station				
				Intelligent device station		Remote device station		Remote I/O station
				Ver.2 compatible	Ver.1 compatible	Ver.2 compatible	Ver.1 compatible	Ver.1 compatible
L series master/local module, QJ61BT11N	Master station	Ver.2 mode	Ver.2 compatible area	○	○	○	○	○
			Ver.1 compatible area	—	—	—	—	—
		Additional mode	Ver.2 compatible area	○	×	○	×	×
			Ver.1 compatible area	×	○	×	○	○
		Ver.1 mode	Ver.2 compatible area	—	—	—	—	—
			Ver.1 compatible area	—	○	—	○	○
	Local station	Ver.2 mode	Ver.2 compatible area	—	—	—	—	—
			Ver.1 compatible area	—	—	—	—	—
		Additional mode	Ver.2 compatible area	—	—	—	—	—
			Ver.1 compatible area	—	—	—	—	—
		Ver.1 mode	Ver.2 compatible area	—	—	—	—	—
			Ver.1 compatible area	—	—	—	—	—
	Intelligent device station		Ver.2 compatible	—	—	—	—	—
			Ver.1 compatible	—	—	—	—	—
Remote device station		Ver.2 compatible	—	—	—	—	—	
		Ver.1 compatible	—	—	—	—	—	
Remote I/O station		Ver.1 compatible	—	—	—	—	—	

○: Cyclic transmission enabled, ×: Cyclic transmission disabled, —: Prohibited

3

3.4 Mode Selection  
3.4.1 Expanded cyclic setting

- Transient transmission

The following table indicates whether send/receive of transient data is enabled or not.

Send station		Receive station							
		Master station			Local station			Intelligent device station	
		Ver.2 mode	Additional mode	Ver.1 mode	Ver.2 mode	Additional mode	Ver.1 mode	Ver.2 mode	Ver.1 mode
Master station	Ver. 2 mode	—	—	—	○	—	○	○	○
	Additional mode	—	—	—	○	○	○	○	○
	Ver.1 mode	—	—	—	—	—	○	—	○
Local station	Ver. 2 mode	○	○	—	○	○	×	—	—
	Additional mode	—	○	—	○	○	×	—	—
	Ver.1 mode	○	○	○	×	×	○	—	—
Intelligent device station	Ver.2 mode	○	○	—	—	—	—	—	—
	Ver.1 mode	○	○	○	—	—	—	—	—

○: Transient transmission enabled, ×: Transient transmission disabled, —: Prohibited

### (c) Differences in functions between the modes of the L series master/local module

The following table lists differences in functions between the modes of the L series master/local module.

Item	Mode of the L series master/local module		
	Remote net Ver.1 mode, remote I/O net mode	Remote net Ver.2 mode	Remote net additional mode
Storage area for RX/Ry/RWr/RWw	Ver.1 compatible area	Ver.2 compatible area	Ver.1-compatible station: Ver.1-compatible area Ver.2-compatible station: Ver.2-compatible area
RWr/RWw of remote I/O stations	4 points per station <sup>*1</sup>	0 point (RWr and RWw move over forward.)	4 points per station
Zero points setting for a reserved station	Not available	Available	Not available
Remote I/O station points setting	Not available	Available	Not available

\*1 For the remote I/O net mode, RWr/RWw is not used.

## 3.5 I/O Signal List

---

The following describes the I/O signal list of the L series master/local module.

The "n" in the table indicates the master/local module's first I/O number of the L series, which is determined by both the installation position and the module installed before the L series master/local module.

**Ex** When the master/local module's first I/O number of the L series is X/Y30  
 Xn0 to X(n+1)F → X30 to X4F  
 Yn0 to Y(n+1)F → Y30 to Y4F

Signal direction: Programmable controller CPU ← L series master/local module				Signal direction: Programmable controller CPU → L series master/local module			
Input number	Signal name	Availability		Output number	Signal name	Availability	
		Master station	Local station			Master station	Local station
Xn0	Module error	○	○	Yn0	Use prohibited	—	—
Xn1	Host data link status	○	○	Yn1			
Xn2	Use prohibited	—	—	Yn2			
Xn3	Other station data link status	○	○	Yn3			
Xn4	Use prohibited	—	—	Yn4			
Xn5				Yn5			
Xn6				Yn6			
Xn7				Yn7			
Xn8				Yn8			
Xn9				Yn9			
XnA				YnA			
XnB				YnB			
XnC				YnC			
XnD				YnD			
XnE				YnE			
XnF				Module ready			
X(n+1)0	Use prohibited	—	—	Y(n+1)0			
X(n+1)1				Y(n+1)1			
X(n+1)2				Y(n+1)2			
X(n+1)3				Y(n+1)3			
X(n+1)4				Y(n+1)4			
X(n+1)5				Y(n+1)5			
X(n+1)6				Y(n+1)6			
X(n+1)7				Y(n+1)7			
X(n+1)8				Y(n+1)8			
X(n+1)9				Y(n+1)9			
X(n+1)A				Y(n+1)A			
X(n+1)B				Y(n+1)B			
X(n+1)C				Y(n+1)C			
X(n+1)D				Y(n+1)D			
X(n+1)E				Y(n+1)E			
X(n+1)F				Y(n+1)F			

○: Available, —: Not available



The use-prohibited output signals shown in the I/O signal list are used by the system and cannot be used by the user. In the event these signals are used (turned on/off) by the user, normal operations cannot be guaranteed.

## 3.6 Buffer Memory List

The buffer memory is used for data exchange between the L series master/local module and a programmable controller CPU.

Data can be read or written by parameter settings in GX Works2 or with dedicated instructions.

The contents of the buffer memory return to the default when the power is turned OFF or the programmable controller CPU is reset.

The following shows the buffer memory list.

When a standby master station is used, refer to the respective columns under "Availability" in the table as explained below.

- When a standby master station is operating as a master station: "Master station" column
- When a standby master station is operating as a standby master station: "Local station" column

Address		Item	Description	Read/write possibility	Availability		Reference
Hexadecimal	Decimal				Master station	Local station	
0 <sub>H</sub> ⋮ DF <sub>H</sub>	0 ⋮ 223	Parameter information area	Stores the parameter settings.	Read only	○ <sup>*4</sup>	—	Page 389, Appendix 2 (1)
E0 <sub>H</sub> ⋮ 15F <sub>H</sub>	224 ⋮ 351	Remote input (RX) <sup>*2</sup>	For the master station: Stores the input status from the slave stations.	Read only	○	—	
			For the local station: Stores the input status from the master station.		—	○	
160 <sub>H</sub> ⋮ 1DF <sub>H</sub>	352 ⋮ 479	Remote output (RY) <sup>*2</sup>	For the master station: Stores the output status to the slave stations.	Write only	○	—	Page 392, Appendix 2 (2)
			For the local station: Stores the output status to the master station. Also, stores the receive data from the remote/other local/intelligent device/standby master stations.	Read/write enabled	—	○	

Address		Item	Description	Read/write possibility	Availability		Reference
Hexadecimal	Decimal				Master station	Local station	
1E0 <sub>H</sub> ⋮ 2DF <sub>H</sub>	480 ⋮ 735	Remote register (RWw) <sup>*2</sup> Master station: For sending Local station: For sending/receiving	For the master station: Stores the send data to the remote device/all local /intelligent device/standby master stations.	Write only	○	—	Page 396, Appendix 2 (3)
			For the local station: Stores the send data to the master/other local/intelligent device/standby master stations. Also, stores the receive data from the remote device/other local/intelligent device/standby master stations.	Read/write enabled	—	○	
2E0 <sub>H</sub> ⋮ 3DF <sub>H</sub>	736 ⋮ 991	Remote register (RWr) <sup>*2</sup> Master station: For receiving Local station: For receiving	For the master station: Stores the receive data from the remote device/local/intelligent device/standby master stations.	Read only	○	—	
			For the local station: Stores the receive data from the master station.		—	○	
3E0 <sub>H</sub> ⋮ 5DF <sub>H</sub>	992 ⋮ 1503	Slave station offset, size information	Stores the offset and size of RX/Ry/RWw/RWr per slave station.	Read only	○	○	Page 399, Appendix 2 (4)
5E0 <sub>H</sub> ⋮ 5FF <sub>H</sub>	1504 ⋮ 1535	Link special relay (SB)	Stores the data link status.	Read/write enabled (write may be disabled depending on the device)	○	○	Page 402, Appendix 2 (5)
600 <sub>H</sub> ⋮ 7FF <sub>H</sub>	1536 ⋮ 2047	Link special register (SW)	Stores the data link status.		○	○	Page 403, Appendix 2 (6)
800 <sub>H</sub> ⋮ 9FF <sub>H</sub>	2048 ⋮ 2559	Use prohibited <sup>*1</sup>	—	—	—	—	—
A00 <sub>H</sub> ⋮ FFF <sub>H</sub>	2560 ⋮ 4095	Random access buffer	The specified data is stored and used by transient transmission.	Read/write enabled	○	○	Page 403, Appendix 2 (7)
1000 <sub>H</sub> ⋮ 1FFF <sub>H</sub>	4096 ⋮ 8191	Communication buffers	Stores the send and receive data and control data when performing transient transmission (communication using this buffer) with the local station, standby master station, and intelligent device station.	Read/write enabled	○	○	Page 403, Appendix 2 (8)
2000 <sub>H</sub> ⋮ 2FFF <sub>H</sub>	8192 ⋮ 12287	Automatic update buffer	Stores the automatically updated data when performing transient transmission with the AJ65BT-R2N (communication using the automatic update buffer).	Read/write enabled	○	—	Page 404, Appendix 2 (9)

Address		Item	Description	Read/write possibility	Availability		Reference
Hexadecimal	Decimal				Master station	Local station	
3000 <sub>H</sub> ⋮ 3FFF <sub>H</sub>	12288 ⋮ 16383	Use prohibited <sup>*1</sup>	—	—	—	—	—
4000 <sub>H</sub> ⋮ 41FF <sub>H</sub>	16384 ⋮ 16895	Ver.2 compatible remote input (RX) <sup>*3</sup>	For the master station: Stores the input status from the slave stations. For the local station: Stores the input status from the master station.	Read only	○ —	— ○	Page 405, Appendix 2 (10)
4200 <sub>H</sub> ⋮ 43FF <sub>H</sub>	16896 ⋮ 17407	Ver.2 compatible remote output (RY) <sup>*3</sup>	For the master station: Stores the output status to the slave stations. For the local station: Stores the output status to the master station. Also, stores the receive data from the remote/other local/intelligent device/standby master stations.	Write only Read/write enabled	○ —	— ○	
4400 <sub>H</sub> ⋮ 4BFF <sub>H</sub>	17408 ⋮ 19455	Ver.2 compatible remote register (RWw) <sup>*3</sup> Master station: For sending Local station: For sending/receiving	For the master station: Stores the send data to the remote device/all local /intelligent device/standby master stations. For the local station: Stores the send data to the master/other local/intelligent device/standby master stations. Also, stores the receive data from the remote device/other local/intelligent device/standby master stations.	Write only Read/write enabled	○ —	— ○	Page 407, Appendix 2 (11)
4C00 <sub>H</sub> ⋮ 53FF <sub>H</sub>	19456 ⋮ 21503	Ver.2 compatible remote register (RWr) <sup>*3</sup> Master station: For receiving Local station: For receiving	For the master station: Stores the receive data from the remote device/local/intelligent device/standby master stations. For the local station: Stores the receive data from the master station.	Read only	○ —	— ○	
5400 <sub>H</sub> ⋮ 7FFF <sub>H</sub>	21504 ⋮ 32767	Use prohibited <sup>*1</sup>	—	—	—	—	—

○: Available, —: Not available

\*1 Do not write any data to the use-prohibited area. Writing data to the "Use prohibited" area may cause malfunction of the programmable controller system.

\*2 Used when the remote net ver.1 mode or the remote net additional mode is selected.

\*3 Used when the remote net ver.2 mode or remote net additional mode is selected.

\*4 Not available for the standby master station (when it is controlling).

# CHAPTER 4 PROCEDURE BEFORE OPERATION

This chapter explains the procedure before operation.

The following describes the procedure before operation.

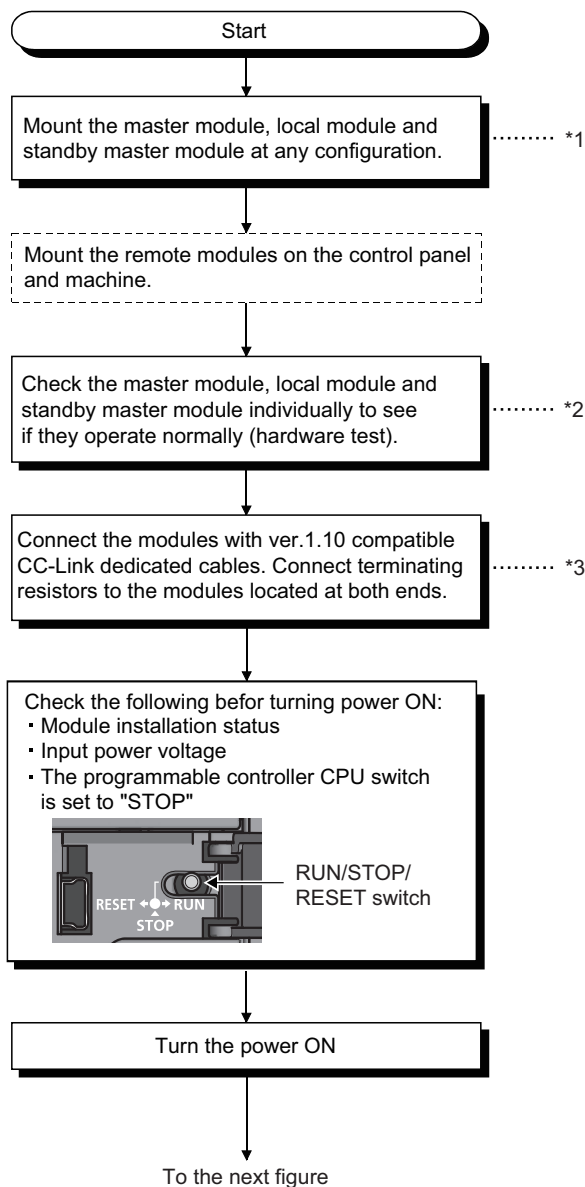

\*1  MELSEC-L CPU Module User's Manual (Hardware Design, Maintenance and Inspection)

\*2  Page 60, Section 6.2

\*3  Page 62, Section 6.3



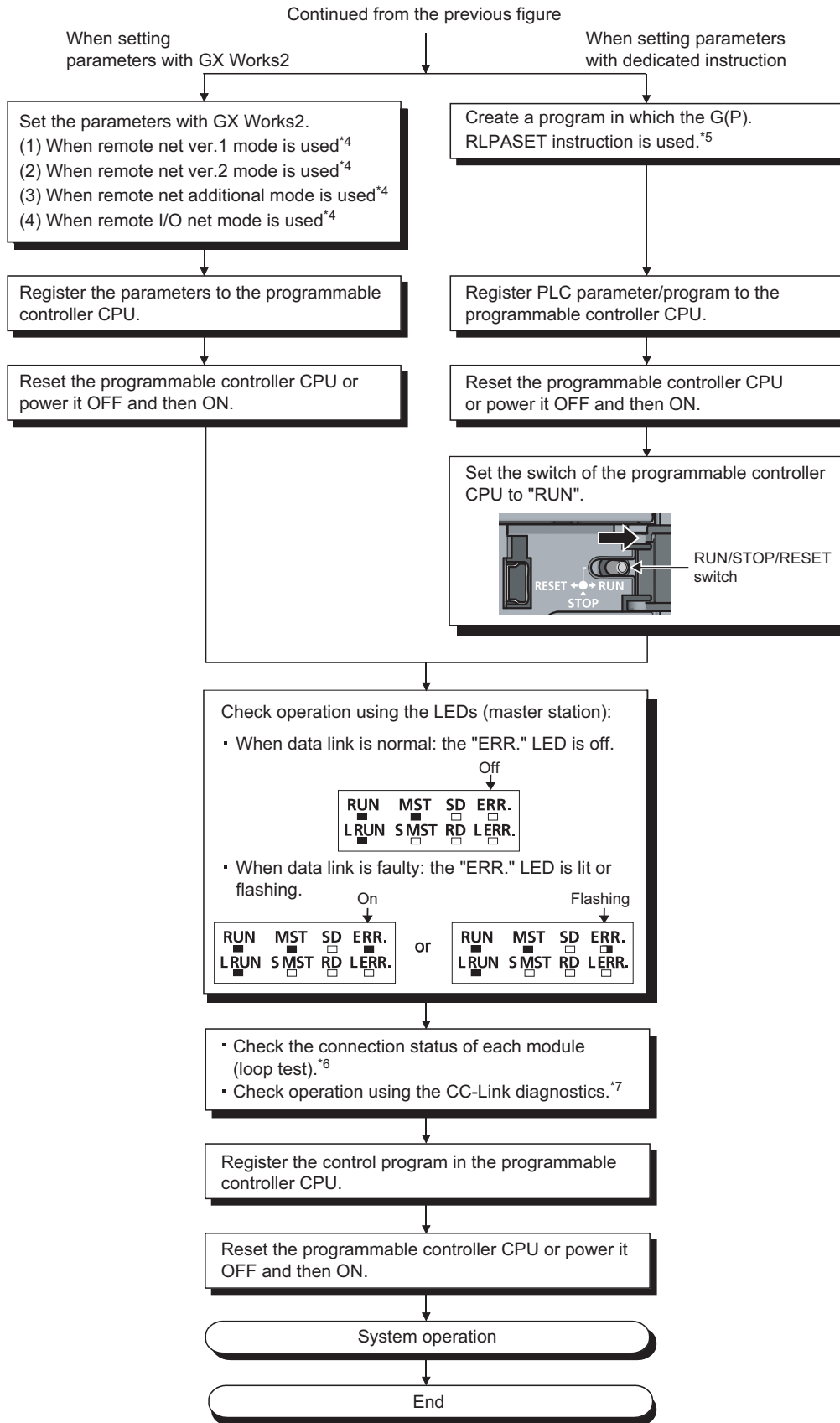

\*4 Page 72, CHAPTER 7  
 \*5 Page 221, Section 9.1.8  
 \*6 Page 67, Section 6.5  
 \*7 Page 375, Section 15.4

# CHAPTER 5 SYSTEM CONFIGURATION

This chapter explains the system configuration of the L series master/local module and the number of connectable modules.

## 5.1 System Configuration

### 5.1.1 System configuration of the L series master/local modules

#### (1) When using the built-in CC-Link function

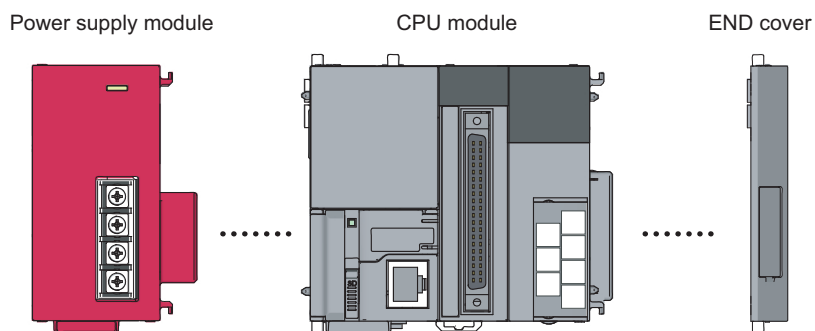

#### (2) When using the LJ61BT11

##### (a) Connecting to the CPU module

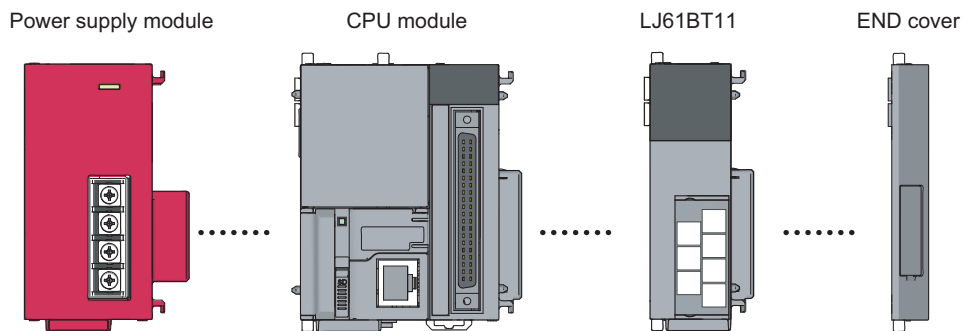

##### (b) Connecting to the head module

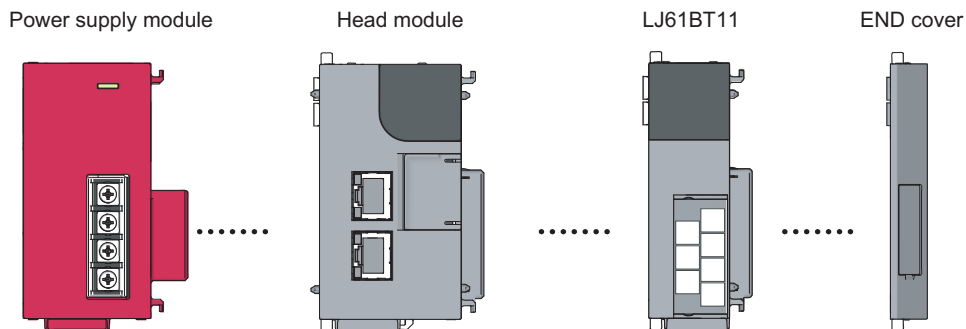

## 5.1.2 System configuration on CC-Link

The following shows a system configuration.

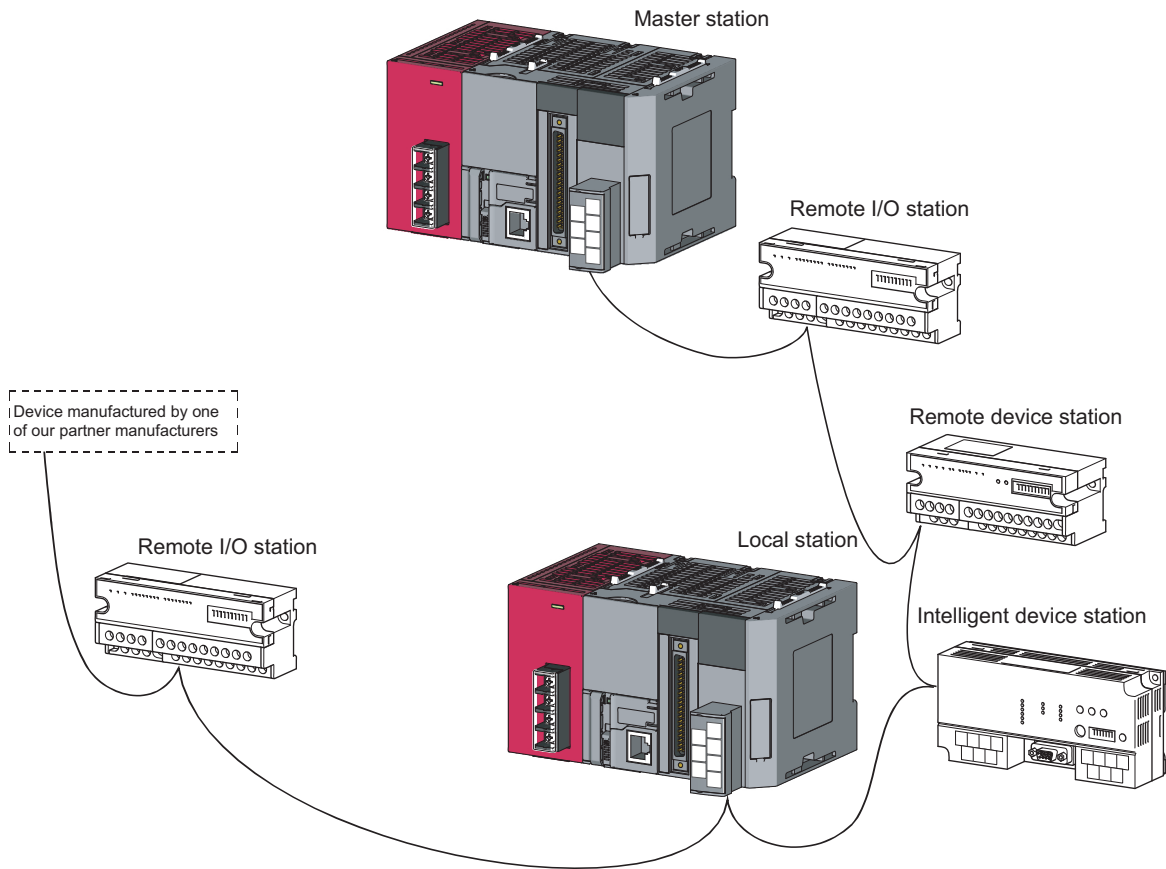

## 5.2 Applicable System

---



Applicable programmable controller CPUs and precautions on the system configuration are described below.

### 5.2.1 Applicable modules and number of connectable modules

---



#### (1) Modules applicable to the LJ61BT11, and number of connectable modules

Refer to the following manual.

-  MELSEC-L CPU Module User's Manual (Hardware Design, Maintenance and Inspection)
-  MELSEC-L CC-Link IE Field Network Head Module User's Manual

#### (2) Compatible software package

Refer to the following manual.

-  MELSEC-L CPU Module User's Manual (Hardware Design, Maintenance and Inspection)
-  MELSEC-L CC-Link IE Field Network Head Module User's Manual

#### (3) Usable slave stations

Both of ver.1 and ver.2 compatible slave stations can be used.

### 5.2.2 Restrictions on use with the head module

---

The following shows the restrictions when using the LJ61BT11 connected to the head module.

**(1) "Interrupt Setting" in Network Parameter is not available.**

**(2) The automatic CC-Link startup function cannot be used.**

**(3) Dedicated instructions cannot be used.**

In addition, the following slave stations cannot be connected when parameters are set with dedicated instructions.

- AJ65BT-R2N
- AJ65BT-D75P2-S3

## 5.2.3 Precautions on the system configuration

### (1) When using the remote station

This section describes notes to be paid attention upon system design to prevent an incorrect input from a remote station.

#### (a) When powering on or off

Start the data link after turning on the power to remote I/O modules.

Turn off the power to remote I/O modules after stopping the data link.

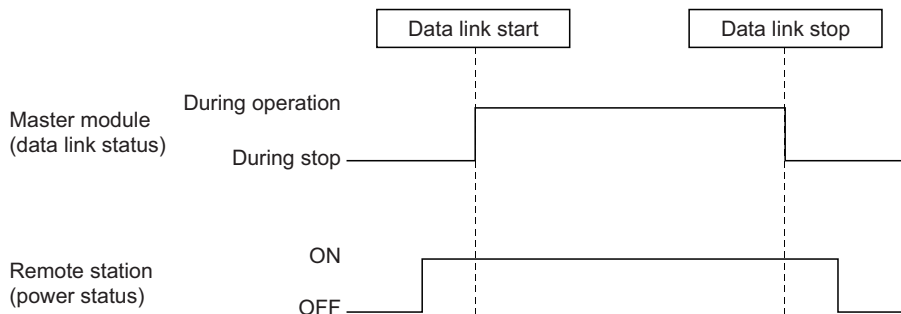

### (2) During momentary power failure of remote I/O modules

When a momentary power failure occurs in the power (24VDC) supplied to remote I/O modules, incorrect input may occur.

- Cause for incorrect input due to a momentary power failure

The remote I/O module hardware uses the power by internally converting the module power (24VDC) to 5VDC.

When a momentary power failure occurs in a remote I/O module, the following condition occurs: (Time for the 5VDC power in the remote I/O module to turn off) > (Response time for input module on and off)

Therefore, incorrect input occurs when a refresh is performed within the time indicated by 1) in the figure below.

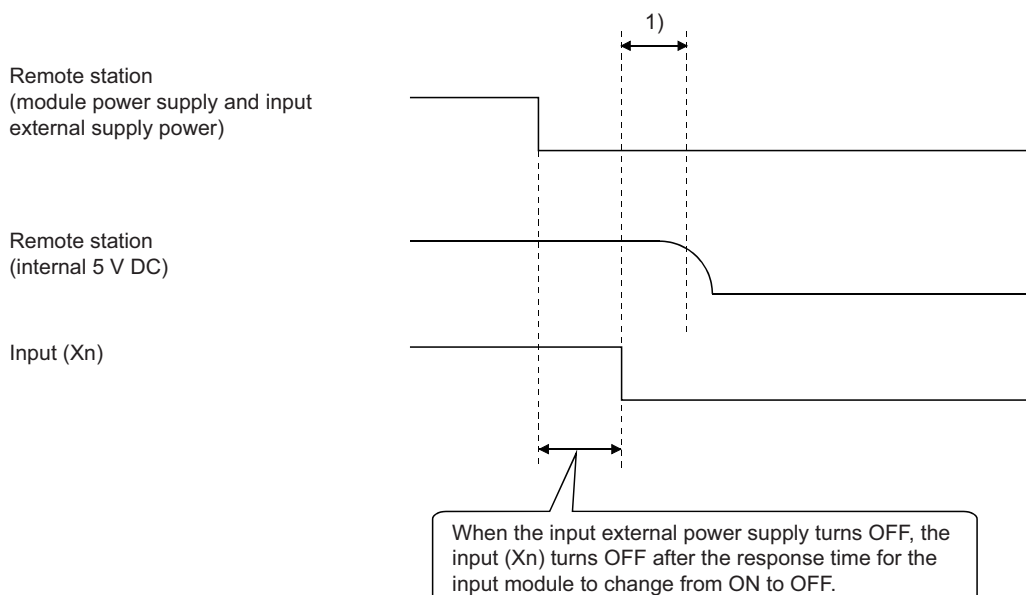

- Countermeasure for incorrect input

To the power supply module, the stabilized power supply and the external supply power of AC input, connect power cables from the same power source.

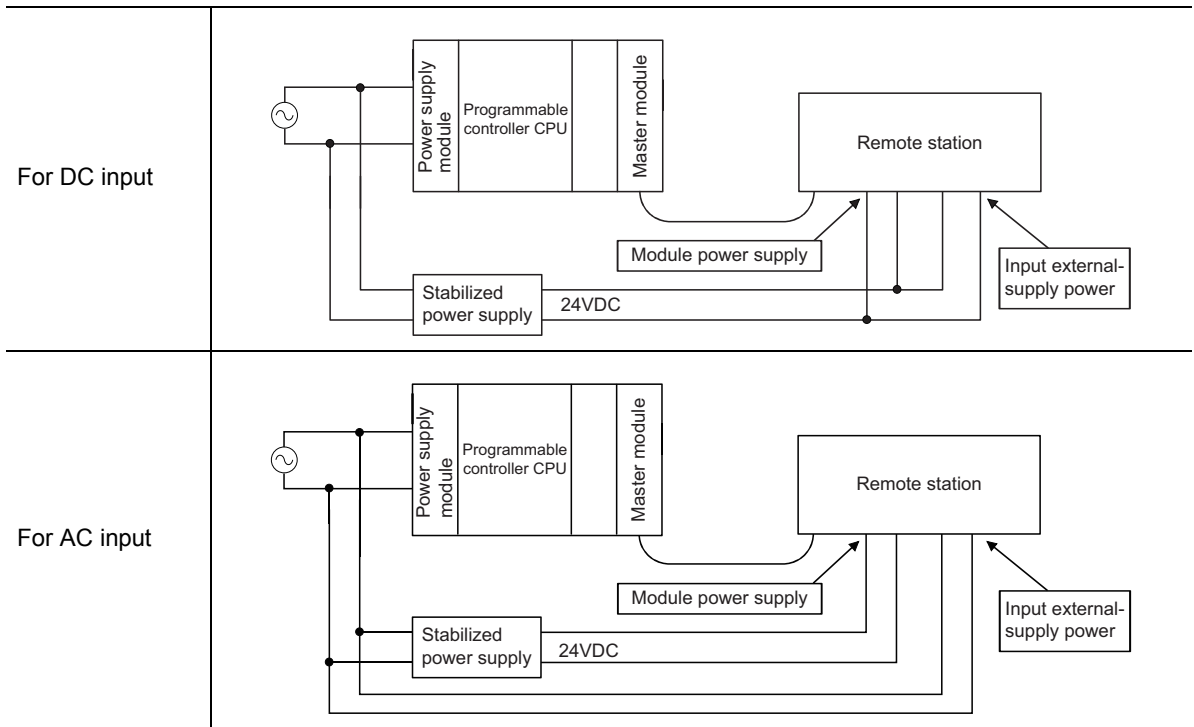

**Remark**

When supplying power from a single power source to multiple remote stations, select the proper type of cable and perform the wiring, taking into account a voltage drop. Connections can be established if the receiving port voltage at the remote stations is within the specified range of the remote stations to be used.

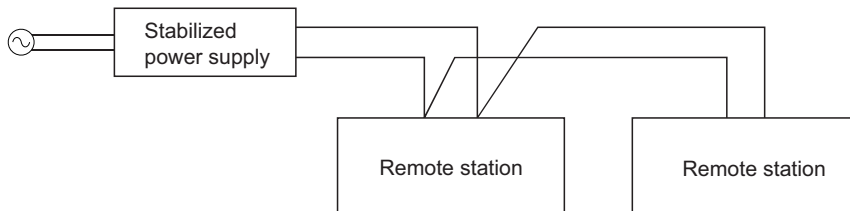

### (3) Access to station No.64

- (a) **To a local station of No. 64, other station access from GX Works2 or GOT is not allowed.**

If the station No. is changed to any of 0 to 63, other station access is executable.

- (b) **From the CC-Link board, other station access is not allowed to access a local station or intelligent device station whose station No. is 64.**

If the station No. is changed to any of 0 to 63, other station access is executable.

### (4) Precautions on the retry count setting for use of dedicated instructions

Note that some dedicated instructions are not applicable to the retry count setting. For details, refer to  Page 192, Section 9.1.1 (3).

For the retry count setting for use of dedicated instructions, there are no restrictions on CPU module models.

# CHAPTER 6 INSTALLATION AND CONNECTION



---

This chapter describes the installation and connection of the L series master/local modules.

## 6.1 Module Installation Environment and Position

---

Refer to the following manual.

-  MELSEC-L CPU Module User's Manual (Hardware Design, Maintenance and Inspection)
-  MELSEC-L CC-Link IE Field Network Head Module User's Manual

### 6.1.1 Handling precautions

---

- (1) Before installing or removing the module, shut off the external power supply for the system in all phases.**

Failure to do so may result in electric shock or cause the module to fail or malfunction.

- (2) Use the programmable controller in an environment that meets the general specifications shown in "Safety Guidelines", the manual supplied with the CPU module or head module.**

Failure to do so may result in electric shock, fire, malfunction, and damage to or deterioration of the product.

- (3) Do not drop the module case and terminal block and do not apply a strong impact since they are made of resin.**

- (4) Do not remove the printed-circuit board of each module from its case.**

This may cause a failure in the module.

- (5) To interconnect modules, engage the respective connectors and securely lock the module joint levers.**

Incorrect interconnection may cause malfunction, failure, or drop of the module.

- (6) Do not directly touch any conductive parts and electronic components of the module.**

Doing so may cause malfunction or failure of the module.



**(7) Prevent foreign matter such as dust or wire chips from entering the module.**

Such foreign matter can cause a fire, failure, or malfunction.

**(8) A protective film is attached to prevent foreign matter, such as wire chips, from entering the module during wiring.**

Do not remove this film until the wiring is complete.

Remove it for heat dissipation before system operation.

**(9) Solderless terminals with insulation sleeve cannot be used for the terminal block.**

It is recommended to cover the connection part of the solderless terminal with a marking tube or an insulation tube.

**(10) Before handling the module, touch a conducting object such as a grounded metal to discharge the static electricity from the human body.**

Failure to do so may cause the module to fail or malfunction.

**(11) Tighten the terminal screws within the following torque range.**

Screw	Tightening torque range
Terminal block screw (M3 screw)	0.42 to 0.58N·m
Terminal block mounting screw (M3.5 screw)	0.66 to 0.89N·m

**Point**

- Be sure to power off the station before installing or removing the terminal block. If the terminal block is installed or removed without powering off the station, correct data transmission cannot be guaranteed.
- Always power off the system in advance when installing or removing a terminating resistor to change the system. If the terminating resistor is installed or removed while the system is energized, normal data transmission will not be guaranteed.

## 6.2 Hardware Test

The hardware test checks whether or not each module works properly by itself.  
Always perform this hardware test before configuring the system.

### Point!

Be sure to execute the hardware test in the following status.

- Perform this hardware test by itself and without connecting any CC-Link Ver.1.10 compatible cable. If the hardware test is performed with the cable connected, it may result in an abnormal termination.
- Execute the hardware test in the condition where no CPU error has occurred. If the hardware test is performed with a CPU error occurred, the test may not be completed.

Execute the hardware test using the following procedure.

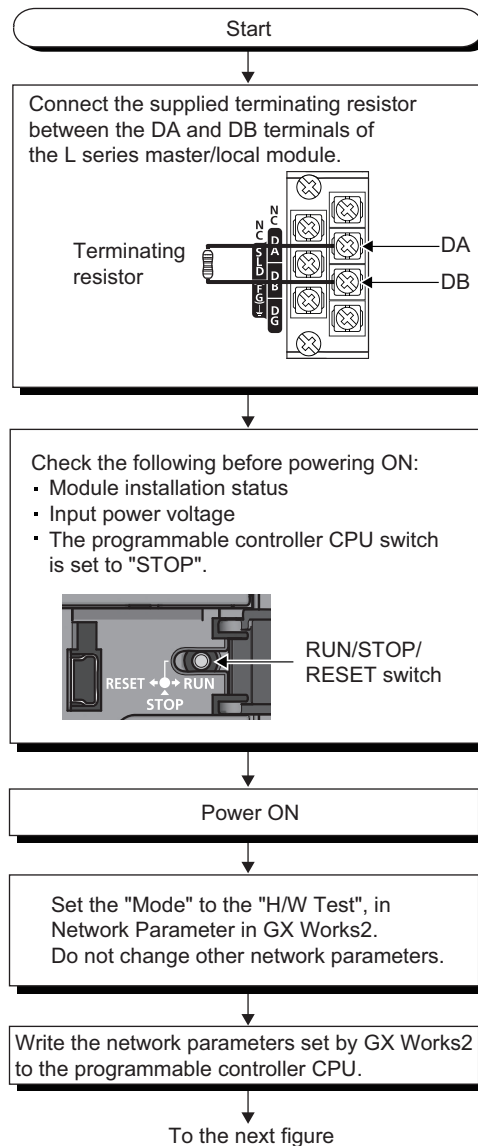

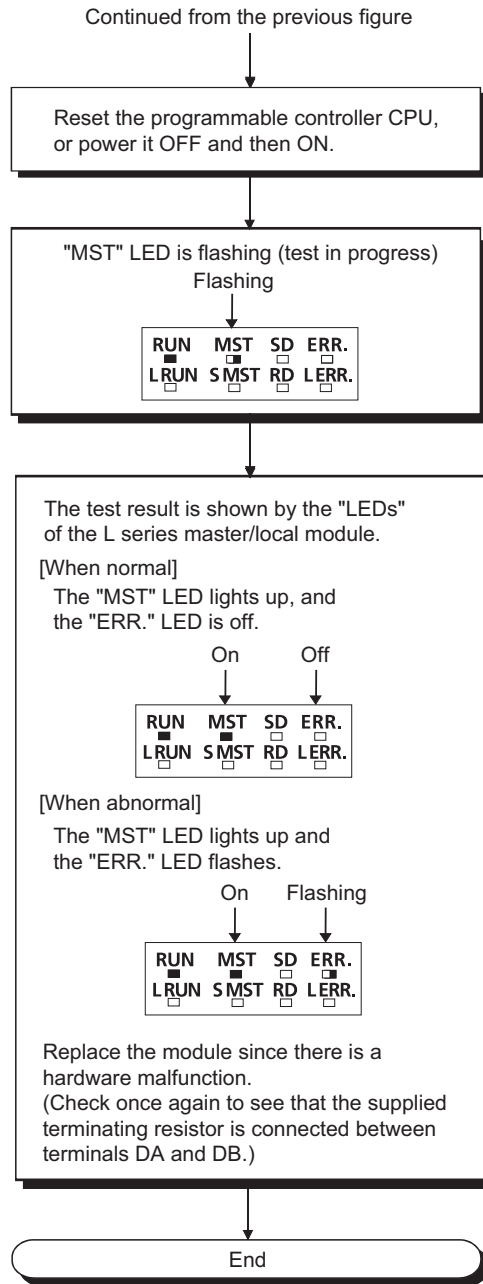

## 6.3 Connecting Modules with Ver.1.10 Compatible CC-Link Dedicated Cables

This section explains how to connect the master module, local modules, standby master module, remote modules and intelligent device modules with the Ver.1.10 compatible CC-Link dedicated cables.

- (1) Cables can be connected in any order, regardless of station numbers.
- (2) Connect the shielded wire of the Ver.1.10 compatible CC-Link dedicated cable to "SLD" of each module, and ground both ends of the shielded wire to the protective ground conductor via "FG".

The SLD and FG are connected within the module.

- (3) M3 screws are used as terminal block screws.
- (4) The following shows the applicable solderless terminals to attach to the terminal block. When wiring, use appropriate cables and install them within the applicable tightening torque range.

Use UL-qualified solderless terminals, and use manufacturer-recommended tools for the process. Note that solderless terminals with insulation sleeves cannot be used.

Solderless terminal		Cable			
Model	Applicable tightening torque	Wire diameter	Type	Material	Rated temperature
1.25-3	0.42 to 0.58N·m	22 to 16 AWG	Stranded cable	Copper wire	60°C or more

- (5) Connect a terminating resistor to each module at both ends of the CC-Link system.

Always connect the supplied "terminating resistors 110Ω 1/2W (brown, brown, brown, gold)" when the modules at the both ends of the CC-Link are L series master/local modules.

Connect each of the terminating resistors between "DA" and "DB".

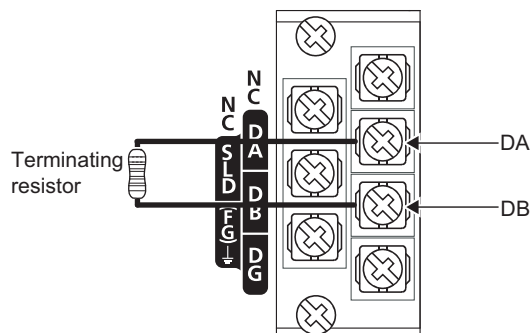

- (6) The master module can be connected at points other than both ends.
- (7) Star connection is not allowed.

(8) The connection method is shown below.

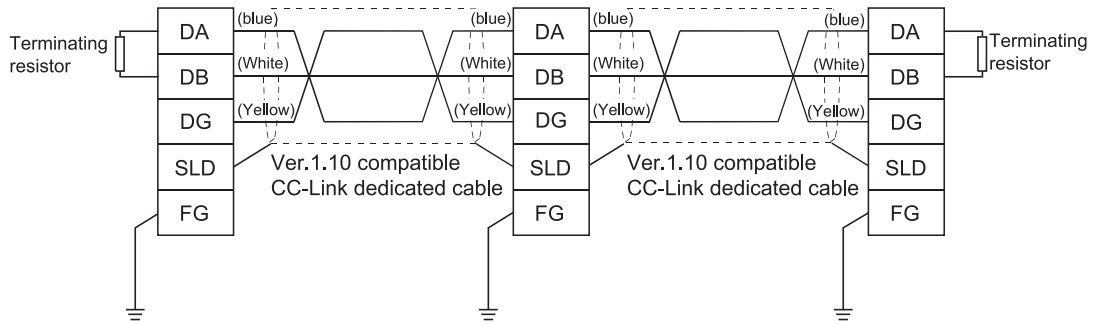

## 6.3.1 Wiring check

The following explains how to check the wiring status between the remote I/O and external devices.

[Example of wiring check]

Specify the "Remote Input(RX)" for the master station to "X1000" and the "Remote Output(RY)" to "Y1000" in GX Works2.

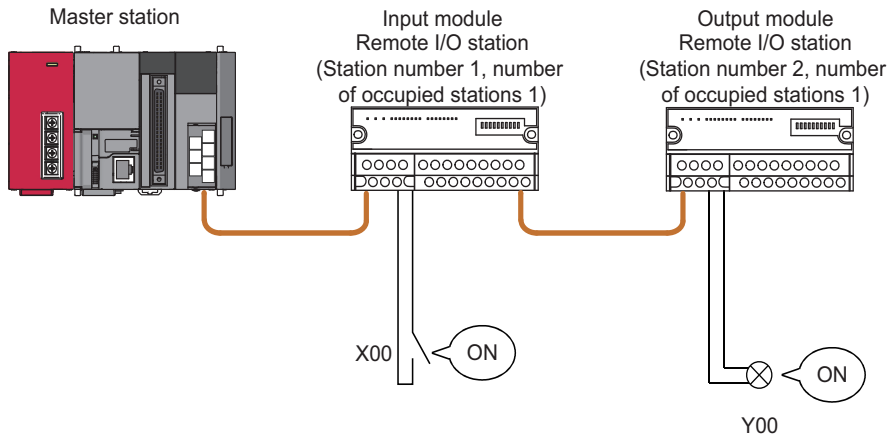

### (1) Checking the wiring between the input module and an external device

1. Turn ON the switch corresponding to the external device "X0," which is connected to the input module of station number 1.
2. Select [Online] ⇨ [Monitor] ⇨ [Device/Buffer Memory Batch] on GX Works2.
3. Set "X1000" in the "Device Name" field.
4. If X1000 is ON, the connection between the input module and external device has been properly made.

### (2) Checking the wiring between the output module and an external device

1. Select [Online] ⇨ [Monitor] ⇨ [Device/Buffer Memory Batch] on GX Works2.
2. Set "Y1020" in the "Device Name" field.
3. Select the monitor data of "Y1020", and then click "Modify Value".
4. Confirm that "Y1020" is set in the "Device/Label" field, and then click "ON".
5. If the connection between the output module and external device is properly made, the indicator lamp corresponding to the external device "Y00" is lit.

#### **Point**

If the X corresponding to the switch does not turn on or the lamp corresponding to the Y does not turn on, check the slave station offset, size information (buffer memory address 3E0<sub>H</sub>, Un\G992) for the RX/R<sub>Y</sub>/R<sub>Ww</sub>/R<sub>W<sub>r</sub></sub> assignment status of the module.

## 6.4 T-Branch Connection

### 6.4.1 T-branch system configuration

The following shows a system configuration using T-branch connection.

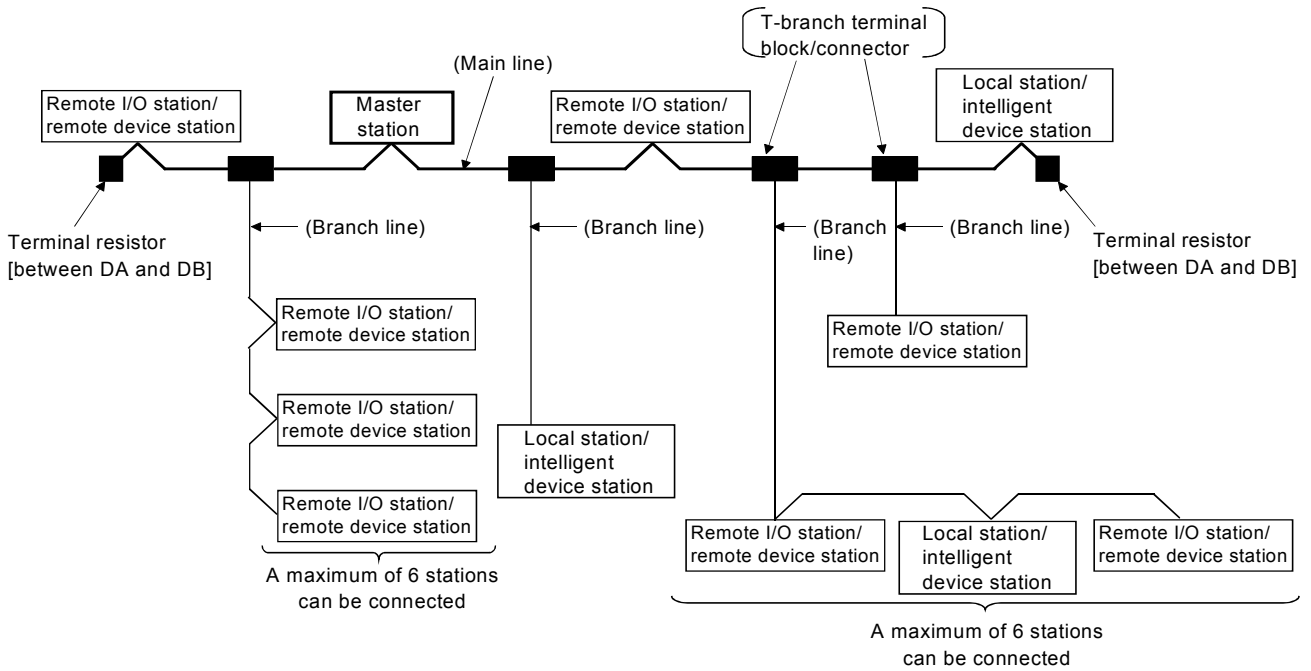

\* The number of branch lines is determined by the branch line length per branch line and the overall branch line length.

6

6.4 T-Branch Connection  
6.4.1 T-branch system configuration

## 6.4.2 T-branch communication specifications list

The following describes the communication specifications for T-branch connection.

For communication specifications not listed below, refer to  Page 26, Section 3.2.

Item	Specification		Remarks	
Transmission speed	625kbps	156kbps	10 M/5 M/2.5 Mbps are not allowed.	
Maximum length of the main line	100m	500m	Indicates the length of the cable between terminating resistors. The length of T branch cable (branch line length) is not included.	
Maximum length of the branch line	8m		Indicates the overall cable length per branch.	
Overall branch line length	50m	200m	Indicates the total length of all branch cables.	
Maximum number of connected stations on the branch line	6 stations per branch		The total number of connected stations depends on the CC-Link specifications.	
Connection cable	Ver. 1.10 compatible CC-Link dedicated cable		—	
T branch Terminal block/connector	<ul style="list-style-type: none"> <li>Terminal block</li> <li>Off-the-shelf terminal block</li> <li>Connector</li> </ul> Product equivalent to an FA sensor connector (IEC947-5-2) is recommended.		<ul style="list-style-type: none"> <li>When wiring cables for the main line side, try not to remove the covering as much as possible.</li> </ul>	
Maximum length of main line, distance between T branches, and length of cable between stations	CC-Link Ver.1.10 compatible cable (uses 110 Ω terminating resistor)			
	Transmission speed	Maximum length of main line	Distance between T branches	Length of cable between the remote I/O stations or remote device stations *1
	625kbps	100m	No limit	30 cm or longer
156kbps	500m	1 m or longer (*3)/2 m or longer (*4)		

\*3: The cable length of 1m or longer is for a system configured only with remote I/O stations and remote device stations.

\*4: The cable length of 2m or longer is for a system configuration that contains local stations and intelligent device stations.

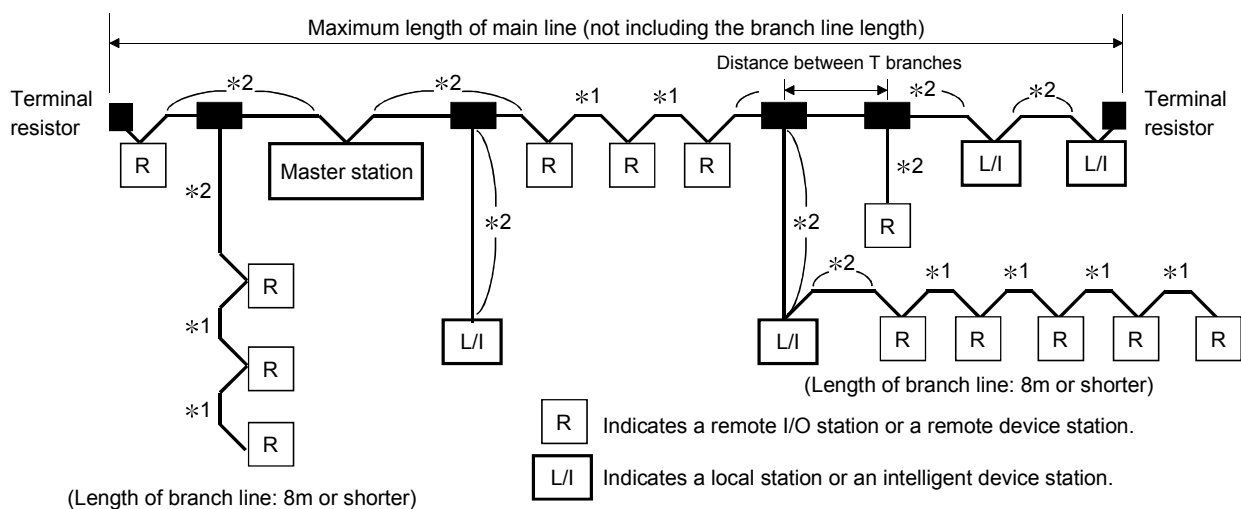



## 6.5 Loop Test

---

Confirm that the master station and slave stations are correctly connected with the Ver.1.10 compatible CC-Link dedicated cables and that data linking can be performed.

Loop test 1 checks the status of communication between the master station and all slave stations connected to the master station. This test is performed during the system start-up.

Loop test 2 checks the status of communication between the master station and the specified slave station. This test is executed when a slave station is added or when an abnormal termination occurs at loop test 1.

### *Point*

---

- Do not set the slave station transmission speed to "Auto-tracking" when performing a loop test. Set the slave station transmission speed as the same as that of the master station (156 kbps to 10 Mbps).  
An abnormal termination may occur in slave stations with transmission speed set to "Auto-tracking" only. In this case, check the cable connection status and the network line status following the troubleshooting procedure.
  - The setting of "Standby Master Station No." in Network Parameter is required to execute Loop test 2 for the standby master station.
  - When data link has started by the standby master station, Loop test 1 and 2 are not executable. To perform these loop tests, use GX Works2.
-

## 6.5.1 Loop test 1

---

Loop test 1 checks the connection status and the status of communication with slave stations.  
Perform the loop test 1 according to the following procedure.

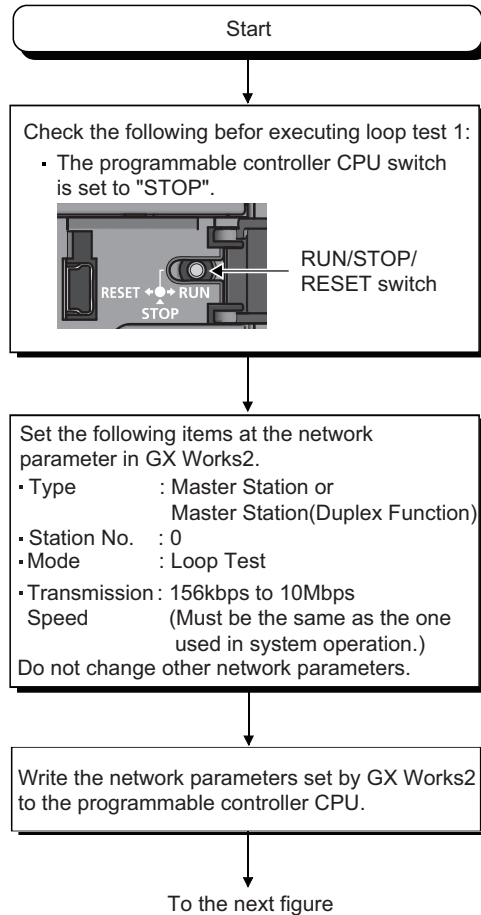

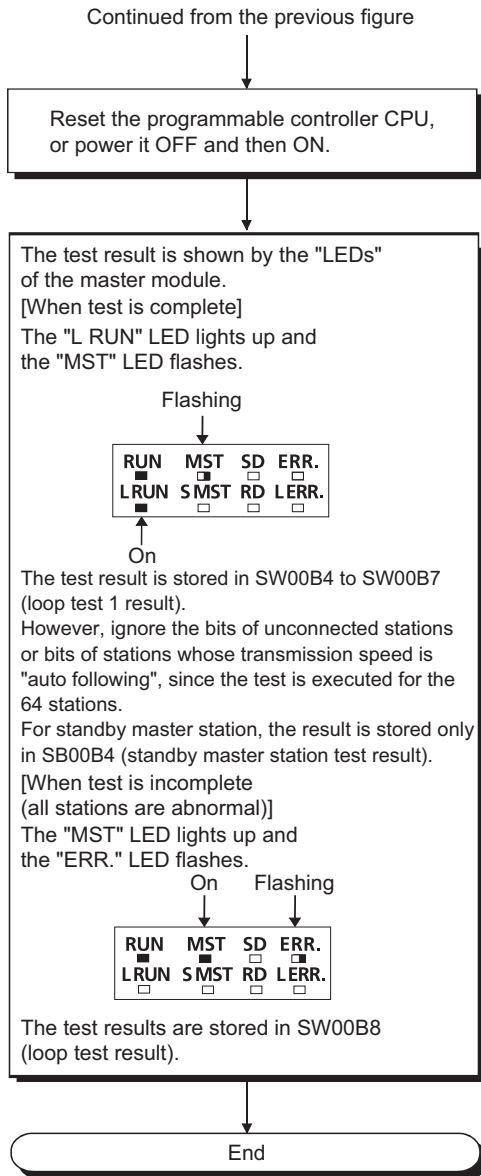

## 6.5.2 Loop test 2

Loop test 2 checks whether data linking can be performed normally with a specified slave station.  
Perform the loop test 2 according to the following procedure.

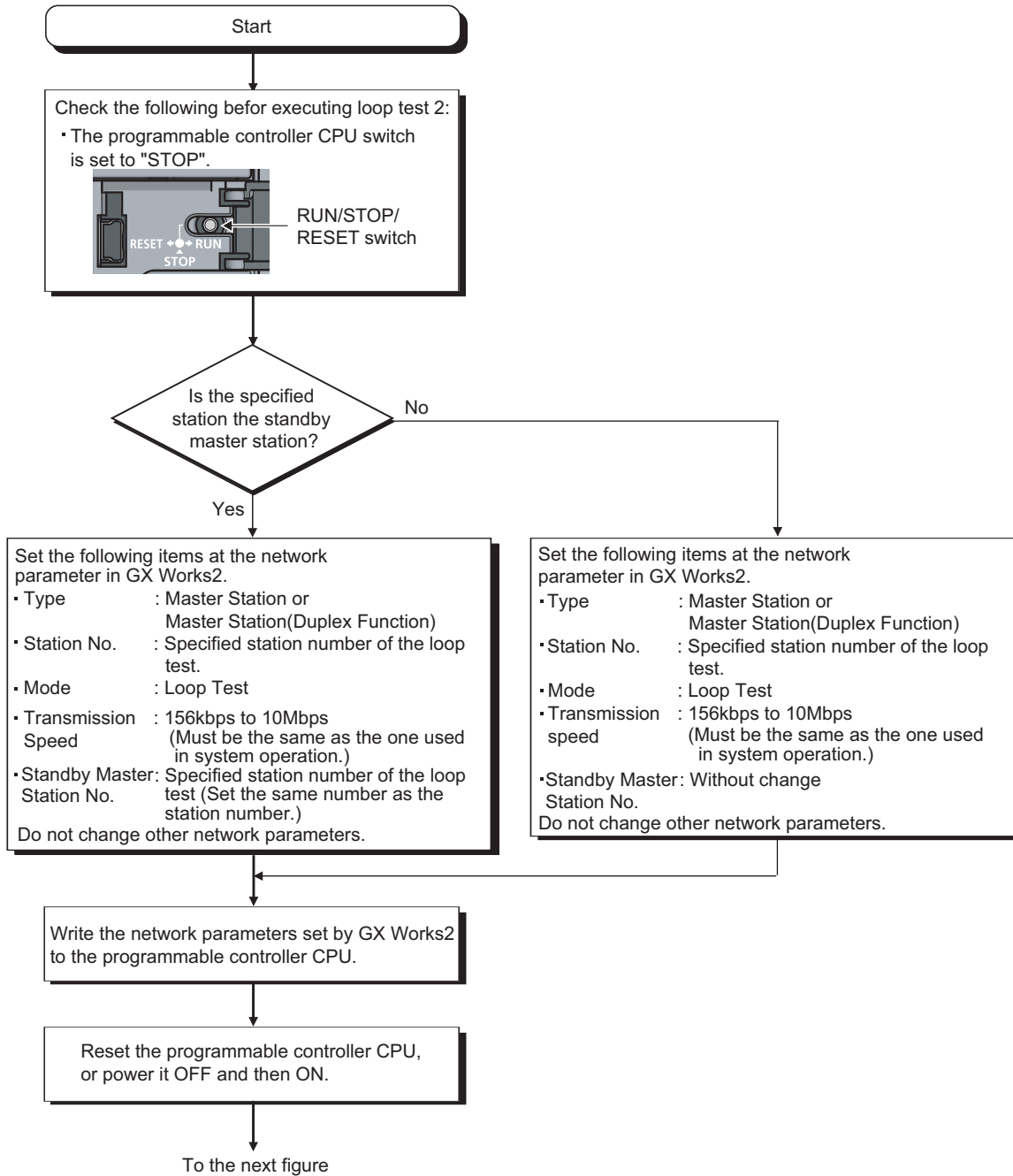

Continued from the previous figure

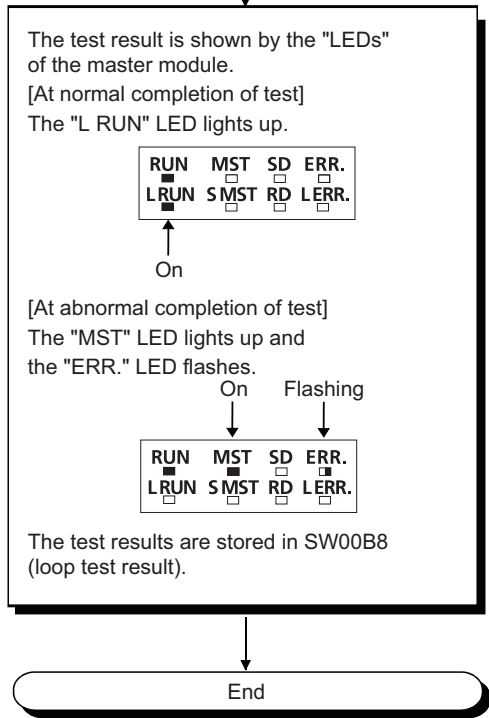

# CHAPTER 7 PARAMETER SETTINGS

For CC-Link, set parameters both for a master station and a slave station.

For a master station, set the information about a slave station to be connected to a CC-Link system.

For a slave station, set the station number of the slave station.

For how to set the parameters of a slave station, refer to the manual for the slave station used.

This chapter describes the parameter settings that are required for L series master/local modules.

## 7.1 Parameter Setting Method

Parameters for the L series master/local module can be set with a programming tool or a dedicated instruction. Select the setting method depending on the application.

Item	Application	Reference
Parameter settings with a programming tool	Use a programming tool for the following cases. <ul style="list-style-type: none"> <li>To set parameters on a window in a simple way, without creating program</li> <li>To transfer data automatically from RX, RY, RWr, RWw, SB, and SW in the L series master/local module to a device in a CPU module</li> </ul>	Page 76, Section 7.3 Page 98, Section 7.4
Parameter settings with the dedicated instruction (G(P).RLPASET instruction)	Use the dedicated instruction for the following cases. <ul style="list-style-type: none"> <li>To connect the maximum number of connectable L series master/local modules to one programmable controller system</li> <li>To change the parameter settings while a CPU module is set to RUN</li> </ul>	Page 221, Section 9.1.8

The following table lists the differences between the two setting methods.

		Parameter setting with GX Works2	Parameter setting with the dedicated instruction	
Program for setting parameters		Not required	Required	
Availability of network parameter settings	Operation Setting	Data Link Faulty Station Setting	N/A	
		Block Data Assurance per Station	N/A	
	Mode	Remote I/O Net Mode	N/A	
	Standby Master Station No.		Available	N/A
	Station Information Setting	Remote Station Points	Available	N/A
	Remote Device Station Initial Setting		Available	N/A
	Interrupt Setting		Available	N/A
Availability of automatic refresh parameter settings		Available	N/A	
Number of the connectable L series master/local modules	LCPU	Available <sup>*1</sup>	Available <sup>*1</sup>	
	Head module	Available <sup>*2</sup>	N/A	
Changing the parameter settings while the programmable controller CPU is in RUN status		N/A	Available	

\*1 For the number of connectable modules, refer to the following.

 MELSEC-L CPU Module User's Manual (Hardware Design, Maintenance and Inspection)

\*2 For the number of connectable modules, refer to the following.

 MELSEC-L CC-Link IE Field Network Head Module User's Manual

**Point** 

- If network parameters are set for modules on a system with both GX Works2 and the G(P).RLPASET instruction, the number of module(s) whose network parameters are set with the G(P).RLPASET instruction should not be included in the "Number of Modules" setting of GX Works2.
- To use the built-in CC-Link function, make sure that "Use built-in CC-Link" has been selected in "PLC Parameter" - "PLC System" - "Built-in CC-Link Setting". (Default: Checked)  
If the built-in CC-Link function is not used, clear the checkbox next to "Use built-in CC-Link" in "Built-in CC-Link Setting". (It will be offline.)

## 7.2 Parameter Setting List

This section lists the parameter setting items for the L series master/local module and whether the settings are required for each station.

○: The setting is available. △: The setting is required if necessary. ×: The setting is not available.

Item	Necessity of the setting		Remark	
	Master station	Local station, standby master station		
Number of Modules	○	○	—	
Start I/O No.	○	○	—	
Operation Setting	Parameter Name	△	△	—
	Data Link Faulty Station Setting	△	△	—
	Case of CPU STOP Setting	△	△	—
	Connected Devices Auto-detection	△	×	Set the setting only when "Remote Net(Ver.1 Mode)", "Remote Net(Ver.2 Mode)" or "Remote Net (Additional Mode)" is set in "Mode".
	Number of Occupied Stations	×	○	—
	Expanded Cyclic Setting	×	○	Set the setting only when "Remote Net(Ver.2 Mode)" or "Remote Net (Additional Mode)" is set in "Mode".
	Block Data Assurance per Station	△	△	—
Type	○	○	The setting is automatically input when "Station Type" is set in the CC-Link configuration window.	
Station No.	×	○	—	
Master Station Data Link Type	×	×	—	
Mode	○	○	The setting is automatically input when "Station Type" is set in the CC-Link configuration window.	
Transmission Speed	△	△	—	
Total Module Connected	○	×	The setting is automatically input when "Station Type" is set in the CC-Link configuration window.	
Remote Input(RX)	△	△	—	
Remote Output(RY)	△	△		
Remote Register(RWr)	△	△		
Remote Register(RWw)	△	△		
Ver.2 Remote Input(RX)	△	△	Set the setting only when "Remote Net (Additional Mode)" is set in "Mode".	
Ver.2 Remote Output(RY)	△	△		
Ver.2 Remote Register(RWr)	△	△		
Ver.2 Remote Register(RWw)	△	△		
Special Relay(SB)	△	△	—	
Special Register(SW)	△	△		
Retry Count	○	×	The settings are not required when "Remote I/O Net Mode" is set in "Mode".	
Automatic Reconnection Station Count	○	×		
Standby Master Station No.	△	×	<ul style="list-style-type: none"> <li>The setting is automatically input when the standby master station is set in the CC-Link configuration window.</li> <li>The setting is not required when "Remote I/O Net Mode" is set in "Mode".</li> </ul>	



Item	Necessity of the setting		Remark
	Master station	Local station, standby master station	
PLC Down Select	○	×	—
Scan Mode Setting	○	×	
Delay Time Setting	○	×	
Station Information Setting	○	×	
Set the station information in the CC-Link configuration window.	△	×	Select the setting when graphically configuring "Station Information Setting" by referring to the network map display area (for GX Works2 only).
Remote Device Station Initial Setting	△	×	The setting is not required when "Remote I/O Net Mode" is set in "Mode".
Interrupt Settings	△	△	—

## 7.3 Parameter Settings for a Master Station

This chapter describes the parameter settings when the L series master/local module is used as a master station.

### 7.3.1 Setting method

**1. Open the "Network Parameter" window on a programming tool.**

Project window ⇨ [Parameter] ⇨ [Network Parameter] ⇨ [CC-Link]

	1	2	3	4
Start I/O No.				
Operation Setting	Operation Setting			
Type	Master Station			
Station No. (*1)	0			
Master Station Data Link Type	PLC Parameter Auto Start			
Mode	Remote Net(Ver. 1 Mode)			
Transmission Speed(*1)	156kbps			
Total Module Connected(*1)	0			
Remote input(RX)				
Remote output(RY)				
Remote register(RWr)				
Remote register(RWw)				
Ver.2 Remote input(RX)				
Ver.2 Remote output(RY)				
Ver.2 Remote register(RWr)				
Ver.2 Remote register(RWw)				
Special relay(SB)				
Special register(SW)				
Retry Count	3			
Automatic Reconnection Station Count	1			
Standby Master Station No. (*1)				
PLC Down Select	Stop			
Scan Mode Setting	Asynchronous			
Delay Time Setting	0			
Station Information Setting	CC-Link Configuration Setting			
Remote Device Station Initial Setting	Initial Setting			
Interrupt Settings	Interrupt Settings			



- 2. Check the checkbox next to "Set the station information in the CC-Link configuration window" at the top of the window.**
- 3. Input settings in the "Network Parameter" window. (Refer to Page 77, Section 7.3.2)**
- 4. Click the [End] button.**
- 5. Write the settings to the CPU module using the programming tool.**  
[Online] ⇨ [Write to PLC]
- 6. The settings are reflected by resetting the CPU module or powering off and on the system. When the reflection is completed, data link is automatically started in the L series master/local modules.**

#### Point

- To change the settings for a master station or a slave station, stop data link in the master station. (Refer to Page 186, Section 8.3.8)
- When the settings for a slave station have been changed, change the settings for the master station accordingly.

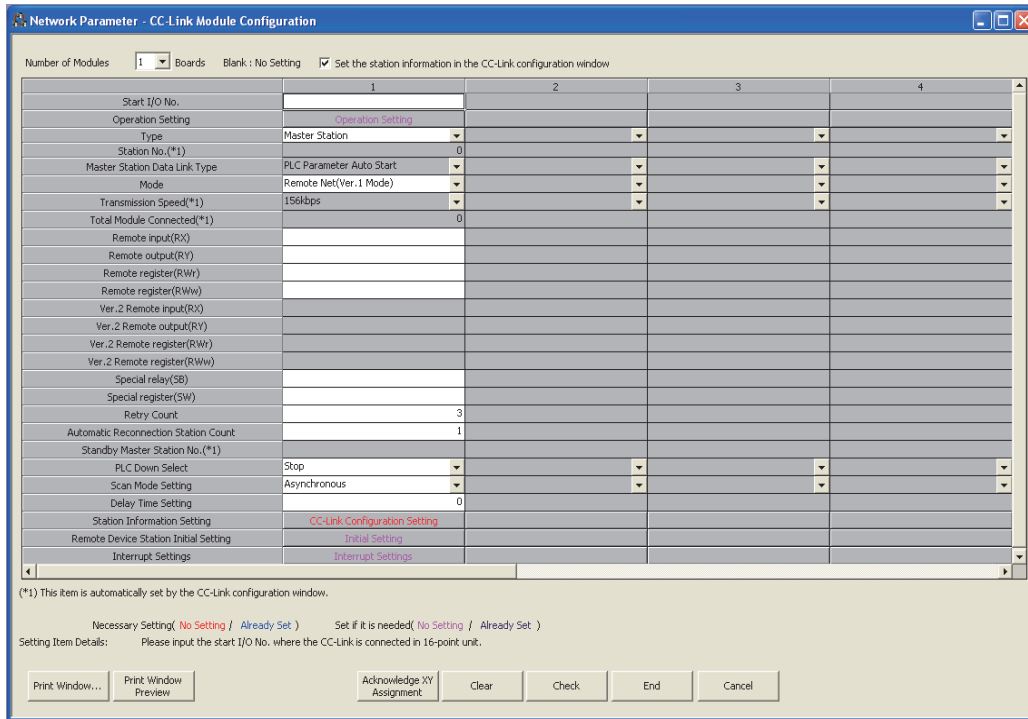
## 7.3.2 Setting details









Item	Description	Setting range
Number of Modules	Select the number of the L series master/local modules that are set using a programming tool. Do not include the number of the L series master/local modules that are set using the dedicated instruction (G(P).RLPASET).	Varies depending on a CPU module. (Refer to  Page 72, Section 7.1) (Default: Blank)
Set the station information in the CC-Link configuration window	Select it when graphically configuring "Station Information Setting" by referring to the network map display area. (Refer to  Page 83, Section 7.3.2 (2).)	<ul style="list-style-type: none"> <li>The station information is not set in the CC-Link configuration window. (The checkbox: Not checked)</li> <li>The station information is set in the CC-Link configuration window. (The checkbox: Checked) (Default: The station information is not set in the CC-Link configuration window. (The checkbox: Not checked))</li> </ul>
Start I/O No.	Set the start I/O number of a master station in units of 16 points.	Within the range of I/O points of the CPU module (Default: Blank)
Operation Setting	Set the operations to be performed upon an error or when the switch on a CPU module is set to STOP. (Refer to  Page 82, Section 7.3.2 (1))	—





7

7.3 Parameter Settings for a Master Station  
7.3.2 Setting details

Item	Description	Setting range	
Type	Select "Master Station". To configure the system that switches the control to the standby master station if the master station goes down, set as follows.	<ul style="list-style-type: none"> <li>• Master Station</li> <li>• Master Station (Duplex Function)</li> </ul> (Default: Master Station)	
	Operation		Setting
	When a failed master station becomes normal again, it does not return as a standby master station.		Master Station
<ul style="list-style-type: none"> <li>• When a failed master station becomes normal again, it returns as a standby master station.</li> <li>• When only the standby master station is started up, it starts data link as a master station.</li> </ul>	Master Station (Duplex Function)		
Station No.	Set the station number of the module.	<ul style="list-style-type: none"> <li>• Master Station: 0</li> <li>• Master Station (Duplex Function): 0 to 64</li> </ul> (Default: 0)	
Master Station Data Link Type	"PLC Parameter Auto Start" is displayed. (The setting is not required.)	—	
Mode	Select the mode of the L series master/local module. (Refer to  Page 35, Section 3.4.) If the mode is selected in the CC-Link configuration window for the station information setting, the mode selected in the CC-Link configuration window is automatically set.	<ul style="list-style-type: none"> <li>• Remote Net(Ver.1 Mode)</li> <li>• Remote Net(Ver.2 Mode)</li> <li>• Remote Net(Additional Mode)</li> <li>• Remote I/O Net Mode</li> <li>• Offline</li> <li>• Loop Test</li> <li>• H/W Test</li> </ul> (Default: Remote Net(Ver.1 Mode))	
Transmission Speed	Set the transmission speed of a module.	<ul style="list-style-type: none"> <li>• 156kbps</li> <li>• 625kbps</li> <li>• 2.5Mbps</li> <li>• 5Mbps</li> <li>• 10Mbps</li> </ul> (Default: 156kbps)	
Total Module Connected	Set the number of slave station (including a reserved station) to connect. If "Set the station information in the CC-Link configuration window" is selected, the setting is automatically input by configuring "Station Information Setting".	1 to 64 (Default: 64)	

Item	Description	Setting range
Remote Input(RX)	<p>Set the start device where data in RX, RY, RWr, and RWw are transferred. By setting these items, data in RX, RY, RWr, and RWw can be automatically transferred to a device in a CPU module without a program.</p> <p>(1) Number of refresh points All points for the station number 1 to the last station number are automatically assigned. (Refer to  Page 392, Appendix 2 (2) and Page 396, Appendix 2 (3).)</p>	<ul style="list-style-type: none"> <li>• Device X, M, L, B, D, W, R, ZR (X and W for a head module)</li> <li>• Device number Within the device range of the CPU module or head module (Default: Blank)</li> </ul>
Remote Output(RY)	<p>To use a different refresh device for each station, transfer data in the devices individually using a program (Un\G□ or FROM/TO instructions). The points for each station can be checked using Slave station offset, size information (buffer memory address: 3E0<sub>H</sub> to 5DF<sub>H</sub>). (Refer to  Page 399, Appendix 2 (4).)</p>	<ul style="list-style-type: none"> <li>• Device Y, M, L, B, T, C, ST, D, W, R, ZR (Y and W for a head module)</li> <li>• Device number Within the device range of the CPU module or head module (Default: Blank)</li> </ul>
Remote Register(RWr)	<p>(2) Buffer memory areas of the refresh sources (Refer to  Page 392, Appendix 2 (2), Page 396, Appendix 2 (3), Page 405, Appendix 2 (10), and Page 407, Appendix 2 (11).)</p>	<ul style="list-style-type: none"> <li>• Device M, L, B, D, W, R, ZR (W for a head module)</li> <li>• Device number Within the device range of the CPU module or head module (Default: Blank)</li> </ul>
Remote Register(RWw)	<ul style="list-style-type: none"> <li>• When "Remote Net(Ver.1 Mode)", "Remote Net(Additional Mode)", or "Remote I/O Net Mode" is set in "Mode", data in the Ver.1-compatible area are transferred to a CPU module.</li> <li>• When "Remote Net(Ver.2 Mode)" is set in "Mode", data in the Ver.2-compatible area are transferred to a CPU module.</li> </ul> <p>(3) To set unique devices Do not set the same device as the following items:</p> <ul style="list-style-type: none"> <li>• Refresh parameters of modules on the network</li> <li>• I/O numbers used for I/O modules and an intelligent function module</li> <li>• Auto refresh settings of an intelligent function module</li> </ul> <p>(4) To set X or Y as a refresh device Set a number later than the I/O numbers used for I/O modules and an intelligent function module.</p> <p>(5) Refresh timing Data are refreshed in the END process of a CPU module.</p>	<ul style="list-style-type: none"> <li>• Device M, L, B, T, C, ST, D, W, R, ZR (W for a head module)</li> <li>• Device number Within the device range of the CPU module or head module (Default: Blank)</li> </ul>

Item	Description	Setting range
Ver.2 Remote Input(RX)	<p>When "Remote Net(Additional Mode)" is set in "Mode", set the start device where data in RX, RY, RWr, and RWw (Ver.2-compatible area) of the L series master/local module are transferred.</p> <p>(1) Number of refresh points</p> <p>All points for the start station number to the last station number of a Ver.2-compatible slave station are automatically assigned. (Refer to  Page 405, Appendix 2 (10) and Page 407, Appendix 2 (11).)</p> <p>To use a different refresh device for each station, transfer the data in the devices individually using a program (Un\G□ or FROM/TO instructions). The points for each station can be checked using Slave station offset, size information (buffer memory address: 3E0<sub>H</sub> to 5DF<sub>H</sub>). (Refer to  Page 399, Appendix 2 (4).)</p> <p>The other contents are same as those for "Remote Input(RX)" described the above.</p>	Same as "Remote Input(RX)"
Ver.2 Remote Output(RY)		Same as "Remote Output(RY)"
Ver.2 Remote Register(RWr)		Same as "Remote Register(RWr)"
Ver.2 Remote Register(RWw)		Same as "Remote Register(RWw)"
Special Relay(SB)	<p>Set the start device where data in SB and SW are transferred. The data in SB and SW can be automatically transferred to a device in a CPU module without a program.</p>	<ul style="list-style-type: none"> <li>• Device M, L, B, D, W, R, SB, ZR (W and SB for a head module)</li> <li>• Device number Within the device range of the CPU module or head module (Default: Blank)</li> </ul>
Special Register(SW)		<ul style="list-style-type: none"> <li>• Device M, L, B, D, W, R, SW, ZR (W and SW for a head module)</li> <li>• Device number Within the device range of the CPU module or head module (Default: Blank)</li> </ul>
Retry Count	Set the number of retries for when a communication failure occurs.	1 to 7 (Default: 3)
Automatic Reconnection Station Count	<p>Set the number of slave stations that return to the system operation by a single link scan after the stations are disconnected due to a communication failure.</p> <p>Setting a larger number extends link scan time of when the station returns.</p>	1 to 10 (Default: 1)
Standby Master Station No.	Set the station number for the standby master station. Set the station number of the station that controls a CC-Link system instead of the master station if a master station goes down. (Refer to  Page 140, Section 8.2.7.)	<ul style="list-style-type: none"> <li>• Blank</li> <li>• 1 to 64 (Default: 64)</li> </ul>
PLC Down Select	Select whether to stop or continue data link if a stop error occurs in a CPU module. (Refer to  Page 132, Section 8.2.3.)	<ul style="list-style-type: none"> <li>• Stop</li> <li>• Continue (Default: Stop)</li> </ul>

Item	Description	Setting range
Scan Mode Setting	<p>Whether to synchronize the link scan with the sequence scan of a CPU module or not can be selected. (Refer to  Page 182, Section 8.3.7.)</p> <ul style="list-style-type: none"> <li>• Asynchronous A link scan does not synchronize with a sequence scan. Input transmission delay time is shortened.</li> <li>• Synchronous A link scan synchronizes with a sequence scan. (The sequence scan and link scan start simultaneously.) Output transmission delay time is shortened. Because of the synchronization, extended sequence scan time increases link scan time.</li> </ul>	<ul style="list-style-type: none"> <li>• Asynchronous</li> <li>• Synchronous</li> </ul> (Default: Asynchronous)
Delay Time Setting	Set 0.	0
Station Information Setting	Set information about a slave station connected to the master station. (Refer to  Page 83, Section 7.3.2 (2).)	—
Remote Device Station Initial Setting	Set the procedure for the initial settings when registering the initial settings of a remote device station using a programming tool. (Refer to  Page 90, Section 7.3.2 (3).)	—
Interrupt Settings	Set the conditions used to issue a request for the interrupt to a CPU module. (Refer to  Page 93, Section 7.3.2 (4).)	—

## (1) Operation Setting

Project window ⇨ [Parameter] ⇨ [Network Parameter] ⇨ [CC-Link] ⇨ [Operation Setting] button

Item	Description	Setting range
Parameter Name	Set the parameter name. (Even if the parameter name is not set, this will not affect the operation of the CC-Link system).	8 characters (Default: Blank)
Data Link Faulty Station Setting	Select whether to clear or hold data input from a data link faulty station. (Refer to  Page 133, Section 8.2.4 and Page 136, Section 8.2.6.)	<ul style="list-style-type: none"> <li>• Clear input data (not checked)</li> <li>• Hold input data (checked)</li> </ul> (Default: Clear input data (not checked))
Case of CPU STOP Setting	Select whether to refresh or clear compulsorily output (sending) data to a slave station when the switch on a CPU module is set to STOP. (Refer to  Page 134, Section 8.2.5 and Page 136, Section 8.2.6.)	<ul style="list-style-type: none"> <li>• Refresh (not checked)</li> <li>• Clear compulsorily (checked)</li> </ul> (Default: Refresh (not checked))
Connected Devices Auto-detection Setting	Select whether or not to read the model name of slave stations with the connected device auto-detection function. To read the model name of the slave stations with the connected device auto-detection function, refer to the following. iQ Sensor Solution Reference Manual	<ul style="list-style-type: none"> <li>• Do not to read the model name of the slave stations (not checked)</li> <li>• Read the model name of the slave stations (checked)</li> </ul> (Default: Do not to read the model name of the slave station (not checked))
Number of Occupied stations	The settings are not required when the L series master/local module is used as a master station.	—
Expanded Cyclic Setting		
Block Data Assurance per Station	Select whether to assure the integrity of cyclic data for each slave station. (Refer to  Page 159, Section 8.2.9.)	<ul style="list-style-type: none"> <li>• Disable setting (not checked)</li> <li>• Enable setting (checked)</li> </ul> (Default: Disable setting (not checked))



## (2) Station Information Setting

### (a) When the checkbox next to "Set the station information in the CC-Link configuration window" is checked

There are two ways to set the parameters.

- Set the parameters by automatically detecting the system configuration; and
- Select modules in "Module List" and drag and drop them to "List of stations".

#### Remark

For how to operate the CC-Link configuration window, refer to the following.

-  GX Works2 Version 1 Operating Manual (Common)

[Set the parameters by automatically detecting of the system configuration]

The time of setting parameters can be reduced by automatically reading information of slave stations connected to the L series master/local module.

The following lists how to set parameters by automatically detecting the system configuration.

1. Check if the station number of slave stations is correctly set.
2. Turn on the slave stations first, and turn on a master station.
3. Open the CC-Link configuration window.

Project window ⇨ [Parameter] ⇨ [Network Parameter] ⇨ [CC-Link] ⇨ [CC-Link Configuration Setting] button.

4. [CC-Link Configuration] ⇨ [Online] ⇨ [Detect Now]

Information of the system configuration obtained from the L series master/local module is reflected to the CC-Link configuration window.

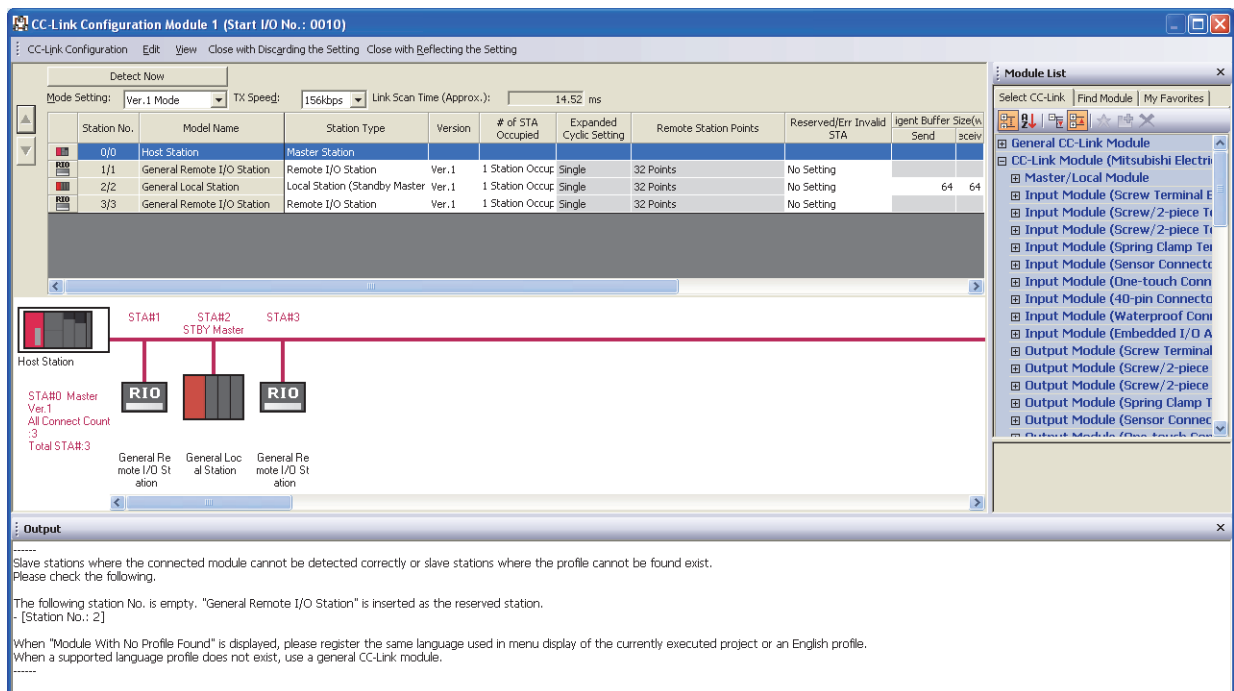

The following items are automatically reflected to the CC-Link Configuration window:

- Station No.
- Station Type \*1
- Version
- # of STA Occupied Stations
- Expanded Cyclic Setting

- \*1 When slave stations are used as local stations, the stations are displayed as intelligent device stations. Change the station type if necessary.
5. When a standby master station exists in the system configuration, the station number of the standby master station is set to the last station number. Change the number corresponding to the actual system configuration.
  6. When the setting is completed, close the CC-Link configuration window by clicking [Close with Reflecting the Setting].

### **Point**

---



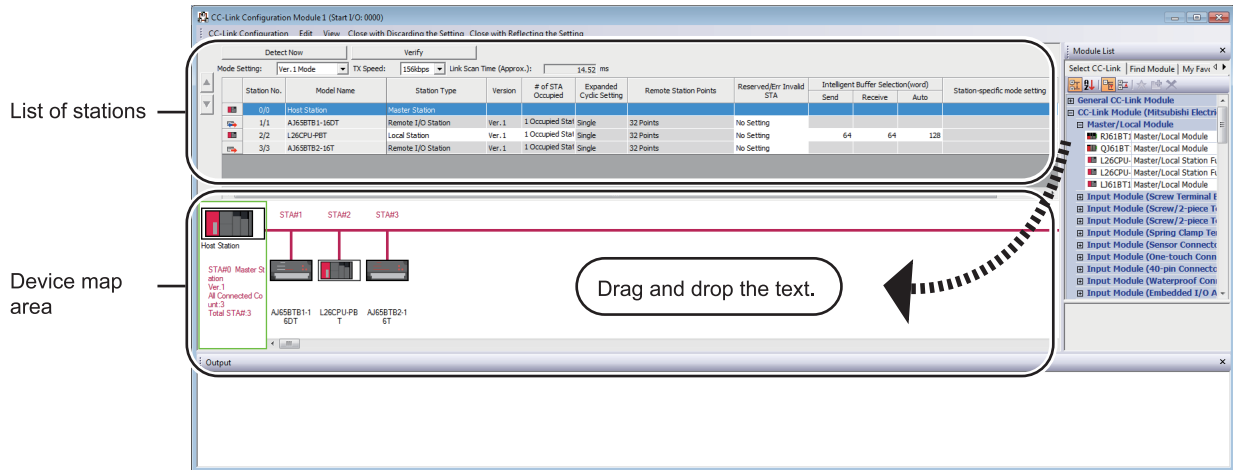

- When the station number is empty, the following items are displayed as:
    - Station Type: Remote I/O Station
    - Version: Ver.1
    - Number of Occupied Stations: Occupied Station 1
    - Expanded Cyclic Setting: Single
    - Remote Station Points: 32Points
    - Reserve/Invalid Station Select: Reserved
  - The connected devices auto-detection function cannot be executed on the station that has switched from a standby master station to a master station.  
To execute the connected devices auto-detection function, follow the procedure below:
    1. Turn off a master station and standby master station.
    2. Turn on the standby master station, then turn on the master station.
    3. Execute the connected devices auto-detection function.
  - To execute the connected devices auto-detection function after a system has been changed (for example, addition or modification of stations), turn on the slave stations then the master station.
-

[Select modules in "Module List" and drag and drop them to "List of stations"]

1. Open the CC-Link configuration window.  
 Project window ⇒ [Parameter] ⇒ [Network Parameter] ⇒ [CC-Link] ⇒ [CC-Link Configuration Setting] button
2. Select modules in "Module List" and drag and drop them to "List of stations".  
 Slave stations are added to "List of stations". The added modules are displayed in the device map area as well.
3. When the setting is completed, close the CC-Link configuration window by clicking [Close with Reflecting the Setting].

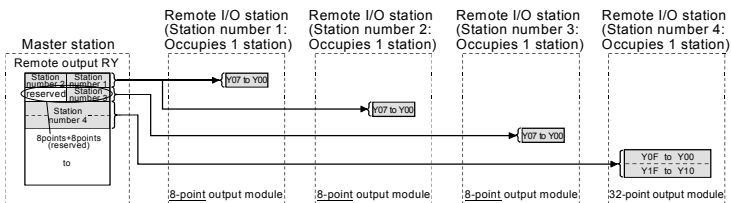

Item	Description	Setting range
Mode Setting	Select the mode of a master station. (Refer to  Page 35, Section 3.4.)	<ul style="list-style-type: none"> <li>• Ver.1 Mode</li> <li>• Ver.2 Mode</li> <li>• Addition Mode</li> <li>• Remote I/O Mode</li> </ul> (Default: Ver.1 Mode)
TX Speed	Select the transmission speed of a master station.	<ul style="list-style-type: none"> <li>• 156kbps</li> <li>• 625kbps</li> <li>• 2.5Mbps</li> <li>• 5Mbps</li> <li>• 10Mbps</li> </ul> (Default: 156kbps)
Link Scan Time (Approx.)	The estimate value of link scan time is displayed.	—
Station No.	<ul style="list-style-type: none"> <li>• For a master station 0/0 is displayed.</li> <li>• For a slave station The order of the slave station is displayed before the slash. The start station number of the slave station is displayed after the slash.</li> </ul>	—
Model Name	The model name of the module is displayed. If the module information cannot be found, "Module without profile" is displayed.	—
Station Type	Select the station type. Set the station type of the slave station actually connected.	Varies depending on the module that was set.

Item	Description	Setting range	
Version	<p>Select the CC-Link version of the slave station.</p> <p>Select the mode of the L series master/local module if the slave station is an L series master/local module. (Refer to  Page 35, Section 3.4.)</p> <p>Select the same CC-Link version as that of the slave station actually connected. If not, data link cannot be performed.</p>	Varies depending on the module that was set.	
# of STA Occupied	Select the number of occupied stations of the slave station.	Varies depending on the module that was set.	
Expanded Cyclic Setting	Select the expanded cyclic setting for the slave station. The setting can be selected only when "Ver.2 Remote Device Station" or "Ver.2 Intelligent Device Station" is set in "Station Type".	Varies depending on the module that was set.	
Remote Station Points	<p>The number of points of remote I/O (RX, RY) occupied by the slave station is displayed.</p> <p>The number of points can be changed for the Ver. 1 remote I/O station when "Remote Net(Ver.2 Mode)" is set in "Mode Setting". Changing the number of points can save the areas of a refresh device in a CPU module. (Refer to  Page 188, Section 8.3.9.)</p> <p>When setting eight points to the remote I/O stations, set them to even numbers of the stations consecutively. When setting eight points to odd numbers of the remote I/O stations, set "8 Points+8 Points (Reserved)" to the last station of consecutive remote I/O stations.</p> 	<ul style="list-style-type: none"> <li>• 0 Point (Reserved Station)</li> <li>• 8 Points</li> <li>• 8 Points+8 Points(Reserved)</li> <li>• 16 Points</li> <li>• 32 Points</li> </ul> <p>(Default: Varies depending on the number of occupied stations)</p>	
Reserved/Err Invalid STA	Select whether to set the slave station as a reserved station or an error invalid station. (Refer to  Page 178, Section 8.3.4, Page 179, Section 8.3.5, and Page 180, Section 8.3.6.)	<ul style="list-style-type: none"> <li>• No Setting</li> <li>• Reserved Station</li> <li>• Error Invalid Station</li> </ul> <p>(Default: No Setting)</p>	
Intelligent Buffer Size (word)	—	Set the size of buffer memory used to perform transient transmission with dedicated instructions. This setting can be configured only for a local station, intelligent device station, and standby master station.	—
	Send	Set the size of send buffer to send data using the G(P).RIWT instruction.	0, 64 to 4096
	Receive	Set the size of receive buffer to receive data using the G(P).RIRD instruction	<p>Note that the total buffer size of "Send" and "Receive" for all slave stations must be 4096 or less.</p> <p>(Default: 64)</p>
	Auto	Set the size of automatic update buffer to communicate with an intelligent device station using automatic update buffer. Set the size required for each intelligent device station.	<p>0, 128 to 4096</p> <p>Note that the total buffer size of "Auto" for all slave stations must be 4096 or less.</p> <p>(Default: 128)</p>
Station-specific mode setting	Set the station-specific mode for the slave station. This setting can be configured only when the slave station supports the station-specific mode.	Varies depending on the module that was set.	

Item		Description	Setting range
Module list	—	The list of slave stations is displayed. Information about slave stations can be set to the master station by dragging and dropping the items from "Module List".	—
	Select CC-Link	The list of CC-Link modules is displayed. Select modules from "General CC-Link Module" if they are not in the list.	
	Find Module	Search for modules by station type or model name. The modules displayed in "Find Result" can be dragged and dropped to "List of stations".	
	My Favorites	The modules registered in "My Favorites" are displayed. To register modules in "My Favorites", perform any of the following. <ul style="list-style-type: none"> <li>• Right-click on a module listed in "Select CC-Link".</li> <li>• Right-click on a module displayed in "Find Result" of "Find Module".</li> </ul>	
Output		Error details are displayed if settings have not been configured properly.	—

**(b) When the checkbox next to "Set the station information in the CC-Link configuration window" is not checked**



1. Set "Mode" and "Total Module Connected" in the "Network Parameter" window and open "CC-Link Station Information" window.

Project window ⇨ [Parameter] ⇨ [Network Parameter] ⇨ [CC-Link] ⇨ [Station Information] button

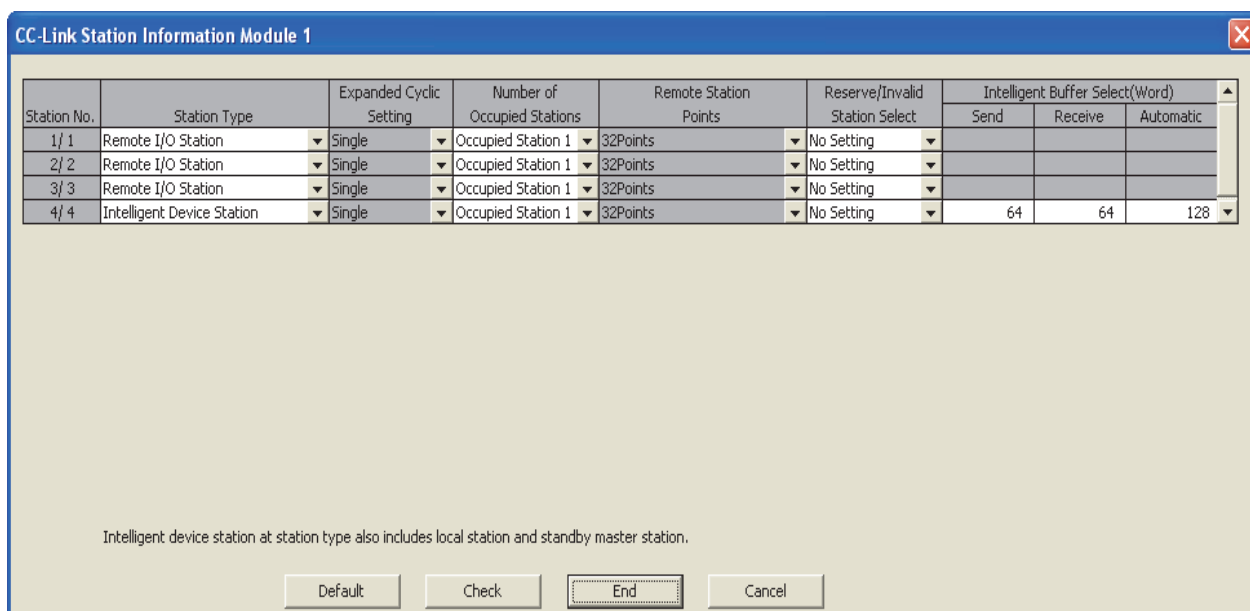
2. Input setting values.
3. When the setting is completed, click the [End] button and close the "CC-Link Station Information" window.

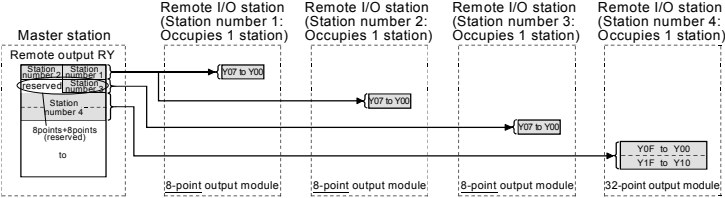

Item	Description	Setting range
Station No.	The order of the slave station is displayed before the slash. The start station number of the slave station is displayed after the slash.	—
Station Type	Select the station type of the slave station. Set the same type of the slave station actually connected.	Varies depending on the mode set in "Mode".
Expanded Cyclic Setting	Select the expanded cyclic setting for the slave station. The setting can be selected only when "Ver.2 Remote Device Station" or "Ver.2 Intelligent Device Station" is set in "Station Type".	<ul style="list-style-type: none"> <li>• Single</li> <li>• Double</li> <li>• Quadruple</li> <li>• Octuple</li> </ul> (Default: Single)
Occupied Count	Select the number of occupied stations of the slave station.	<ul style="list-style-type: none"> <li>• No Setting</li> <li>• Occupied Station 1</li> <li>• Occupied Station 2</li> <li>• Occupied Station 3</li> <li>• Occupied Station 4</li> </ul> (Default: Occupied Station 1)

Item	Description	Setting range	
Remote Station Points	<p>The number of points of remote I/O (RX, RY) occupied by the slave station is displayed.</p> <p>The number of points can be changed for the Ver. 1 remote I/O station when "Remote Net(Ver.2 Mode)" is set in "Mode Setting". Changing the number of points can save the areas of a refresh device in a CPU module. (Refer to  Page 188, Section 8.3.9.)</p> <p>When setting eight points to the remote I/O stations, set them to even numbers of the stations consecutively. When setting eight points to odd numbers of the remote I/O stations, set "8 Points+8 Points(Reserved)" to the last station of consecutive remote I/O stations.</p> 	<ul style="list-style-type: none"> <li>• 0 Points(Reserved Station)</li> <li>• 8 Points</li> <li>• 8 Points+8 Points(Reserved)</li> <li>• 16 Points</li> <li>• 32 Points</li> </ul> <p>(Default: Varies depending on the "Number of Occupied Stations".)</p>	
Reserve/Invalid Station	<p>Select whether to set the slave station as a reserved station or an error invalid station. (Refer to  Page 178, Section 8.3.4, Page 179, Section 8.3.5, and Page 180, Section 8.3.6.)</p>	<ul style="list-style-type: none"> <li>• No Setting</li> <li>• Reserved Station</li> <li>• Invalid Station</li> </ul> <p>(Default: No Setting))</p>	
Intelligent Buffer Select (Word)	---	<p>Set the size of buffer memory used to perform transient transmission with dedicated instructions. This setting can be configured only for an intelligent device station.</p>	---
	Send	<p>Set the size of send buffer to send data using the G(P).RIWT instruction.</p>	0, 64 to 4096
	Receive	<p>Set the size of receive buffer to receive data using the G(P).RIRD instruction.</p>	<p>Note that the total buffer size of "Send" and "Receive" for all slave stations must be 4096 or less. (Default: 64)</p>
	Auto	<p>Set the size of automatic update buffer to communicate with an intelligent device station using automatic update buffer. Set the size required for each intelligent device station.</p>	<p>0, 128 to 4096 Note that the total buffer size of "Auto" for all slave stations must be 4096 or less. (Default: 128)</p>

### (3) Remote Device Station Initial Setting

Register the initial settings using a programming tool, and reflect them to a remote device station using Remote device station initialization procedure registration instruction (SB000D).

Project window ⇨ [Parameter] ⇨ [Network Parameter] ⇨ [CC-Link] ⇨ [Initial Setting] button

- In "Target Station No.", set the station number of the remote device station where the initial settings are configured.  
Set the start station number instead if the number of occupied stations is two or more.
- Click the [Regist Procedure] button.
- Register the procedure for the initial settings in the "Remote Device Station Initial Setting Procedure Registration" window.
- Click the [End] button and close the setting window.

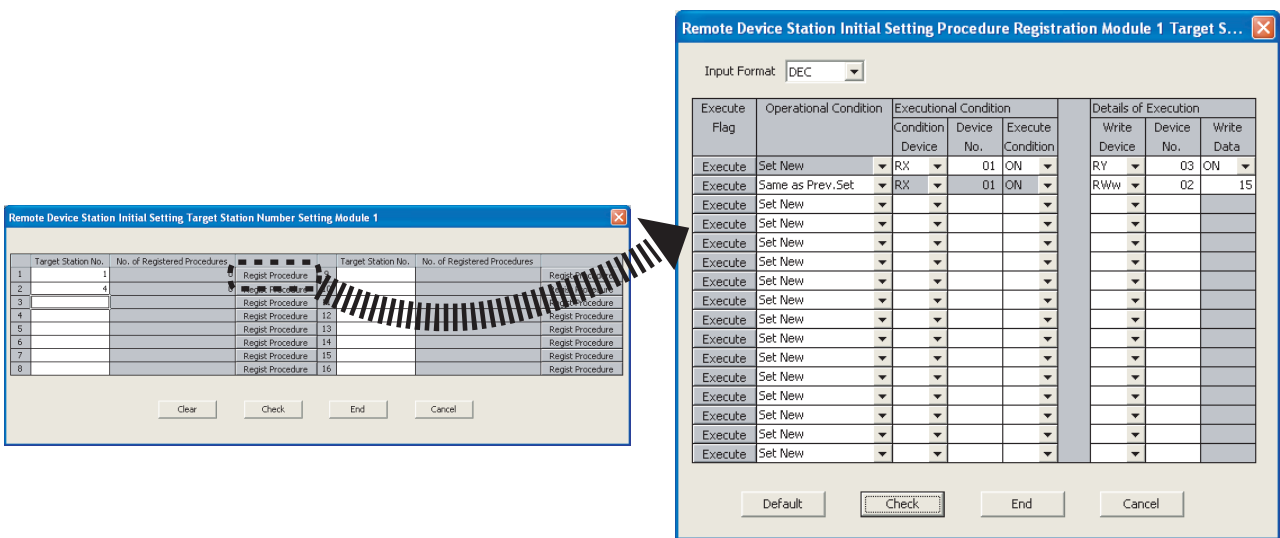

- "Remote Device Station Initial Setting Target Station Number Setting" window

Item	Description	Setting range
Target Station No.	Set the station number of the station where the initial settings are configured.	1 to 64 (Default: Blank)
No. of Registered Procedures	The number of the procedures registered using the [Regist Procedure] button is displayed.	—
[Regist Procedure]	"Remote Device Station Initial Setting Procedure Registration" is displayed by clicking it.	—

- "Remote Device Station Initial Setting Procedure Registration" window

Item	Description	Setting range
Input Format	Select the input format of "Write Data".	<ul style="list-style-type: none"> <li>• DEC</li> <li>• HEX</li> </ul> (Default: DEC)
Execute Flag	Select whether to actually execute the registered procedure or not. Click it to change the setting. Set "Only Set" to use the setting only as a reference when inputting similar setting items.	<ul style="list-style-type: none"> <li>• Execute</li> <li>• Only Set</li> </ul> (Default: Execute)
Operational Condition	Select whether to newly set the condition for the initial settings or use the same condition as the above line.	<ul style="list-style-type: none"> <li>• Set New</li> <li>• Same as Prev. Set</li> </ul> (Default: Set New)



Item	Description	Setting range		
Executorial Condition	—	Set the condition to execute the initial settings.	—	
	Condition Device	Select the device to execute the initial settings.	<ul style="list-style-type: none"> <li>• RX</li> <li>• SB</li> </ul> (Default: Blank)	
	Device No.	Set the device number of the device set in "Condition Device". Set a device with a device number of 0 as the first device of each station. For instance, 0 to 1F can be set to the device number for the station number 4 as shown below.		<ul style="list-style-type: none"> <li>• For RX: 0 to 37FH</li> <li>• For SB: 0 to FFH</li> </ul> (Default: Blank)
	Execute Condition	Select whether to execute the initial settings with ON of the condition device or with OFF of the condition device.	<ul style="list-style-type: none"> <li>• ON</li> <li>• OFF</li> </ul> (Default: Blank)	
Details of Execution	—	Set the device where the initial setting details are written and the data.	—	
	Write Device	Select the device where the initial settings are written.	<ul style="list-style-type: none"> <li>• RY</li> <li>• RWw</li> </ul> (Default: Blank)	
	Device No.	Set the device number of the device set in "Write Device". Set a device with a device number of 0 as the first device of each station. For instance, 0 to 1F can be set to the device number for the station number 4 as shown below.		<ul style="list-style-type: none"> <li>• For RY: 0 to 37FH</li> <li>• For RWw: 0 to 7FH</li> </ul> (Default: Blank)
Write Data	Set the data for the initial settings. (The data to be written to the device set in "Write Device" and "Device No.")	<ul style="list-style-type: none"> <li>• For RY: ON or OFF</li> <li>• For RWw: 0 to 65535 (0 to FFFFH)</li> </ul> (Default: Blank)		

5. When the initial settings are completed, write the settings to the CPU module using a programming tool.  
[Online] ⇔ [Write to PLC]
6. The settings are reflected by resetting the CPU module or powering off and on the system.
7. Turn on Remote device station initialization procedure registration instruction (SB000D) and start the initial settings.  
While the initial settings are being executed, Execution status of remote device station initialization procedure (SB005E) is on.  
Also, the execution procedure number and the target station number for the procedure registration are stored in Remote device station initialization procedure registration execution individual information (SW0110 to SW011F).
8. When the initial settings are completed for all the set stations, Completion status of remote device station initialization procedure (SB005F) is turned on.  
Also, the execution results are stored in Remote device station initialization procedure registration instruction result (SW005F).  
The data stored in Remote device station initialization procedure registration execution individual information (SW0110 to SW011F) become FF\*\*<sub>H</sub>. (\*\* represents the target station number for the initial settings.)
9. Turn off Remote device station initialization procedure registration instruction (SB000D).  
Remote device station initialization procedure registration instruction results (SW005F) and Remote device station initialization procedure registration execution individual information (SW0110 to SW011F) are cleared.

The following figure shows the operations of a link special relay (SB) and link special register (SW) when the remote device station initialization procedure registration is performed.

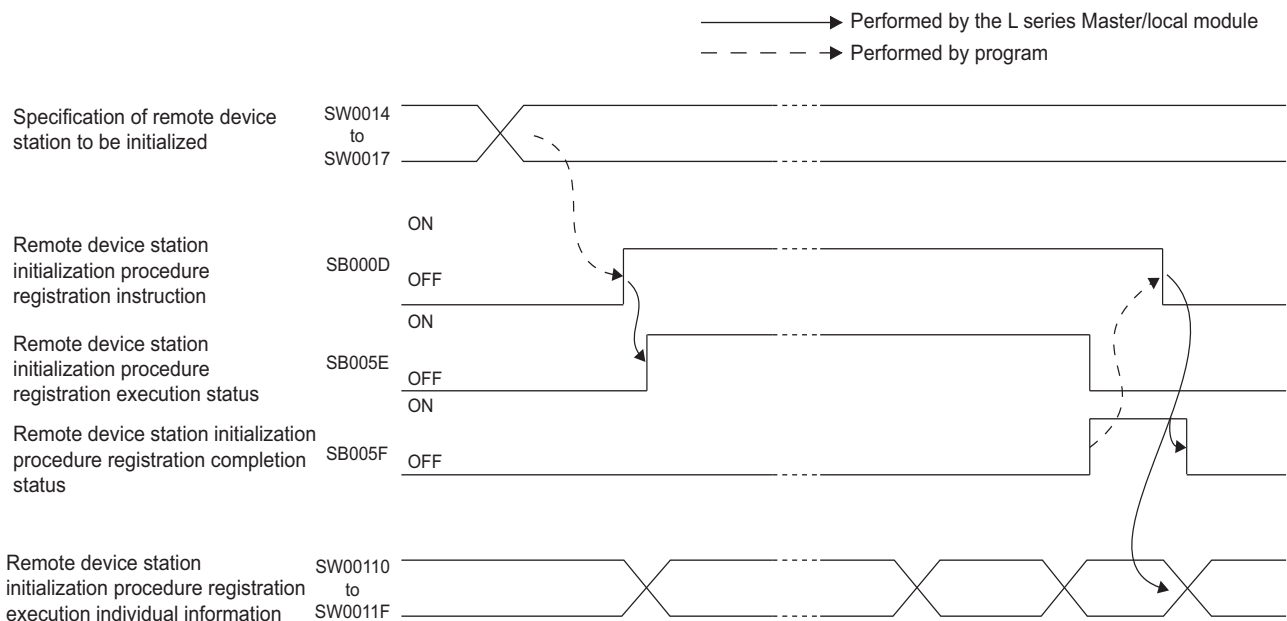

### (4) Interrupt Settings

Project window ⇨ [Parameter] ⇨ [Network Parameter] ⇨ [CC-Link] ⇨ [Interrupt Settings] button

1. In the "Interrupt Settings" window, set the conditions on which the L series master/local module issues the interrupt to a CPU module.
2. Click the [End] button and close the setting window.

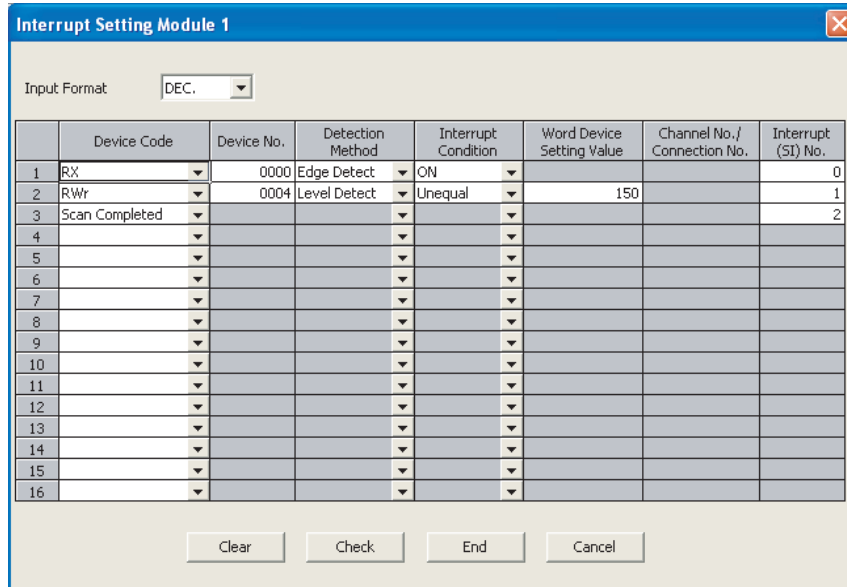

Item	Description	Setting range
Input Format	Select the input format of "Word Device Setting Value".	<ul style="list-style-type: none"> <li>• DEC</li> <li>• HEX</li> </ul> (Default: DEC)
Device Code	Set the device for the interrupt condition.	Refer to the following table on the next page.
Device No.		
Detection Method		
Interrupt Condition		
Word Device Setting Value	Set the word device value for the interrupt condition if RWr or SW is set in "Device Code".	
Channel No./Connection No.	The setting is not required for an L series master/local module.	
Interrupt (SI) No.	Set the interrupt (SI) No. used for the interrupt pointer setting of the PLC parameter.  The interrupt (SI) No. is the control number on the L series master/local module side to issue a request for the interrupt from the L series master/local module to a CPU module. (This is not a device used for an actual program.)	



Only one interrupt condition can be set for one interrupt program.



Item		Description	Setting range
PLC Side	Interrupt Pointer Start No.	Set the start number (I□□) of the interrupt pointer.	50 to 255 (Default: Blank)
	Interrupt Pointer Count	Set the number of the interrupt conditions set in the "Interrupt Settings" window of the network parameter.	1 to 16 (Default: Blank)
Intelligent Module Side	Start I/O No.	Set the start I/O number of the L series master/local module.	Within the range of I/O points of the CPU module (Default: Blank)
	Start SI No.	Set the start number of the SI No. set in "Interrupt (SI) No." in the "Interrupt Settings" window of the network parameter.	0 to 15 (Default: Blank)

### (a) Precautions

[When interrupt conditions are always established with "Level Detect" being set to "Detection Method"]

The interrupt process is performed for each link scan; therefore, if the sequence scan time is much longer than the link scan time, a watchdog timer error may occur in the CPU module due to the prolonged sequence scan.

To avoid this, check the conditions using a program and do not use the interrupt settings.

[Before executing an interrupt program]

Execute the EI instruction in the main routine program and enable the interrupt. (Refer to the MELSEC-L CPU Module User's Manual (Function Explanation, Program Fundamentals).)

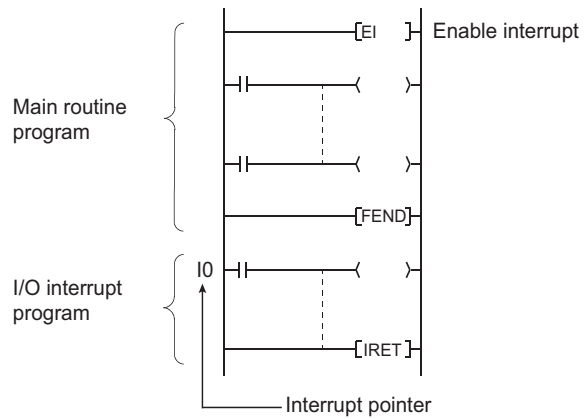

[When multiple interrupts occur simultaneously]

The operation may delay.

[Executing an interrupt program at rise or fall of the specified device]

Do not execute an interrupt program by using the rise (using the PLS instruction) or fall (using the PLF instruction) of the specified device because the device change may not be recognized.

**Ex** Example) Turn on RX10 and issue a request for the interrupt.



Since change of RX10 may not be read, this cannot be specified as interrupt condition.

[When the interrupt cannot be performed]

If the changing time of the device used for the interrupt condition is shorter than the transmission delay time, the device change cannot be detected.

[When using data in an interrupt program]

When an interrupt program is being executed, RX/Ry/RWr/RWw are not automatically refreshed to the device of a CPU module. Therefore, directly access the buffer memory of the L series master/local module with an intelligent function module device (Un\G□).

[When data link is faulty]

A request for the interrupt to a CPU module is not issued.

## 7.4 Parameter Settings for a Local Station and Standby Master Station

This section describes the parameter settings when the L series master/local module is used as a local station or standby master station.

### 7.4.1 Setting method

**1. Open the "Network Parameter" window in a programming tool.**

Project window ⇨ [Parameter] ⇨ [Network Parameter] ⇨ [CC-Link]

	1	2	3	4
Start I/O No.				
Operation Setting	Operation Setting			
Type	Local Station			
Station No.				
Master Station Data Link Type				
Mode	Remote Net(Ver.1 Mode)			
Transmission Speed	Auto-tracking			
Total Module Connected				
Remote input(RX)				
Remote output(RY)				
Remote register(RW)				
Remote register(RWw)				
Ver.2 Remote input(RX)				
Ver.2 Remote output(RY)				
Ver.2 Remote register(RW)				
Ver.2 Remote register(RWw)				
Special relay(SB)				
Special register(SW)				
Retry Count				
Automatic Reconnection Station Count				
Standby Master Station No.				
PLC Down Select				
Scan Mode Setting				
Delay Time Setting				
Station Information Setting				
Remote Device Station Initial Setting				
Interrupt Settings	Interrupt Settings			

**2. Input settings in the "Network Parameter" window.**

**3. Click the [End] button.**

**4. Write the settings to the CPU module using the programming tool.**

[Online] ⇨ [Write to PLC]

**5. The settings are reflected by resetting the CPU module or powering off and on the system. When the reflection is completed, data link is automatically started in the L series master/local modules.**



When changing the settings for a local station or standby master station, change the settings for the master station accordingly.



## 7.4.2 Setting details

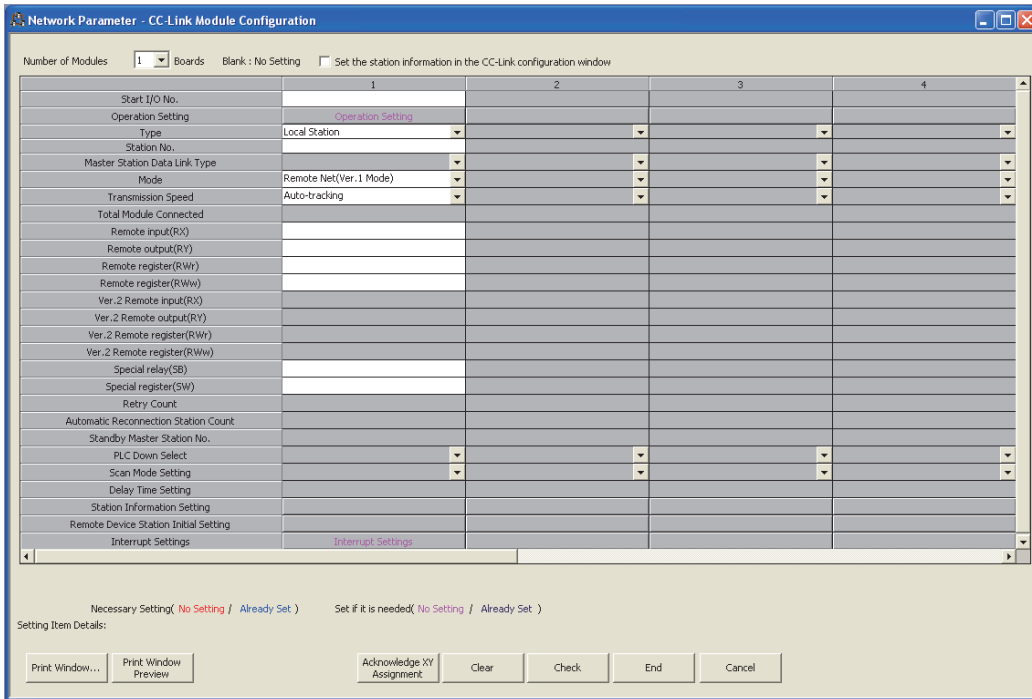







Item	Description	Setting range						
Number of Modules	Select the number of the L series master/local modules. Do not include the number of the L series master/local modules that are set using the dedicated instruction (G(P).RLPASET).	Varies depending on a CPU module. (Refer to  Page 72, Section 7.1.) (Default: Blank)						
Set the station information in the CC-Link configuration window	Checking this item is not necessary for a local station or standby master station.	—						
Start I/O No.	Set the start I/O number of the L series master/local module in units of 16 points.	Within the range of I/O points of the CPU module (Default: Blank)						
Operation Setting	Set the operations to be performed upon an error or when the switch on a CPU module is set to STOP. (Refer to  Page 103, Section 7.4.2 (1).)	—						
Type	Select "Local Station" to use the L series master/local module as a local station. (Refer to  Page 140, Section 8.2.7.)	<ul style="list-style-type: none"> <li>• Master Station (Duplex Function)</li> <li>• Local Station</li> <li>• Standby Master Station</li> </ul> (Default: Master Station)						
	<table border="1"> <thead> <tr> <th>Operation</th> <th>Setting</th> </tr> </thead> <tbody> <tr> <td>When only the standby master station is started up, it starts data link as a master station.</td> <td>Master Station (Duplex Function)*1</td> </tr> <tr> <td>Other than the above</td> <td>Standby Master Station</td> </tr> </tbody> </table>		Operation	Setting	When only the standby master station is started up, it starts data link as a master station.	Master Station (Duplex Function)*1	Other than the above	Standby Master Station
	Operation		Setting					
	When only the standby master station is started up, it starts data link as a master station.		Master Station (Duplex Function)*1					
Other than the above	Standby Master Station							
*1 When selecting "Master Station (Duplex Function)", configure the same settings as those of the master station. (Refer to  Page 77, Section 7.3.2.)								
Station No.	Set the station number.	<ul style="list-style-type: none"> <li>• Local Station, Standby Master Station: 1 to 64</li> <li>• Master Station (Duplex Function): 0 to 64</li> </ul> (Default: Blank)						

7

7.4 Parameter Settings for a Local Station and Standby Master Station  
7.4.2 Setting details

Item	Description	Setting range
Master Station Data Link Type	The setting is not required when the L series master/local module is used as a local station or standby master station.	—
Mode	<p>Set the mode for the L series master/local module. (Refer to  Page 35, Section 3.4.)</p> <p>Set the same mode as that of the master station to use an L series master/local module as a standby master station.</p>	<ul style="list-style-type: none"> <li>• Remote Net(Ver.1 Mode)</li> <li>• Remote Net(Ver.2 Mode)</li> <li>• Remote Net(Additional Mode)</li> <li>• Offline</li> <li>• Loop Test (for "Master Station (Duplex Function)" only)</li> <li>• H/W Test</li> </ul> <p>(Default: Remote Net(Ver.1 Mode))</p>
Transmission Speed	Set the transmission speed of the module.	<ul style="list-style-type: none"> <li>• Auto-tracking (selectable only for a local station and standby master station)</li> <li>• 156kbps</li> <li>• 625kbps</li> <li>• 2.5Mbps</li> <li>• 5Mbps</li> <li>• 10Mbps</li> </ul> <p>(Default: For "Master Station (Duplex Function)": 156kbps, For local stations and standby station: Auto-tracking)</p>
Total Module Connected	The setting is not required when the L series master/local module is used as a local station or standby master station. (This does not apply when "Master Station (Duplex Function)" is selected in "Type".)	—

Item	Description	Setting range
Remote Input (RX)	<p>Set the start device where data in RX, RY, RWr, and RWw are transferred. By setting these items, data in RX, RY, RWr, and RWw can be automatically transferred to a device in a CPU module without a program.</p> <p>(1) Number of refresh points All points for the station number 1 to last station number are automatically assigned. (Refer to  Page 392, Appendix 2 (2) and Page 396, Appendix 2 (3).) To use a different refresh device for each station, transfer the device individually using a program (Un\G□ or FROM/TO instructions). The points for each station can be checked using Slave station offset, size information (buffer memory address: 3E0<sub>H</sub> to 5DF<sub>H</sub>). (Refer to  Page 399, Appendix 2 (4).)</p>	<ul style="list-style-type: none"> <li>• Device X, M, L, B, D, W, R, ZR (X and W for a head module)</li> <li>• Device number Within the device range of the CPU module or head module (Default: Blank)</li> </ul>
Remote Output(RY)	<p>(2) Buffer memory areas of the refresh sources (Refer to  Page 392, Appendix 2 (2), Page 396, Appendix 2 (3), Page 405, Appendix 2 (10), and Page 407, Appendix 2 (11).)</p> <ul style="list-style-type: none"> <li>• When "Remote Net(Ver.1 Mode)", "Remote Net(Additional Mode)", or "Remote I/O Net Mode" is set in "Mode", data in the Ver.1-compatible area are transferred to a CPU module.</li> <li>• When "Remote Net(Ver.2 Mode)" is set in "Mode", data in the Ver.2-compatible area are transferred to a CPU module.</li> </ul> <p>(3) To set unique devices Do not set the same device as the following items:</p> <ul style="list-style-type: none"> <li>• Refresh parameters of modules on the network</li> <li>• I/O numbers used for I/O modules and an intelligent function module</li> <li>• Auto refresh settings of an intelligent function module</li> </ul> <p>(4) To set X or Y as a refresh device Set a number later than the I/O numbers used for I/O modules and an intelligent function module.</p> <p>(5) Refresh timing Data are refreshed in the END process of a CPU module.</p>	<ul style="list-style-type: none"> <li>• Device Y, M, L, B, T, C, ST, D, W, R, ZR (Y and W for a head module)</li> <li>• Device number Within the device range of the CPU module or head module (Default: Blank)</li> </ul>
Remote Register (RWr)	<p>(2) Buffer memory areas of the refresh sources (Refer to  Page 392, Appendix 2 (2), Page 396, Appendix 2 (3), Page 405, Appendix 2 (10), and Page 407, Appendix 2 (11).)</p> <ul style="list-style-type: none"> <li>• When "Remote Net(Ver.1 Mode)", "Remote Net(Additional Mode)", or "Remote I/O Net Mode" is set in "Mode", data in the Ver.1-compatible area are transferred to a CPU module.</li> <li>• When "Remote Net(Ver.2 Mode)" is set in "Mode", data in the Ver.2-compatible area are transferred to a CPU module.</li> </ul> <p>(3) To set unique devices Do not set the same device as the following items:</p> <ul style="list-style-type: none"> <li>• Refresh parameters of modules on the network</li> <li>• I/O numbers used for I/O modules and an intelligent function module</li> <li>• Auto refresh settings of an intelligent function module</li> </ul> <p>(4) To set X or Y as a refresh device Set a number later than the I/O numbers used for I/O modules and an intelligent function module.</p> <p>(5) Refresh timing Data are refreshed in the END process of a CPU module.</p>	<ul style="list-style-type: none"> <li>• Device M, L, B, D, W, R, ZR (W for a head module)</li> <li>• Device number Within the device range of the CPU module or head module (Default: Blank)</li> </ul>
Remote Register (RWw)	<p>(3) To set unique devices Do not set the same device as the following items:</p> <ul style="list-style-type: none"> <li>• Refresh parameters of modules on the network</li> <li>• I/O numbers used for I/O modules and an intelligent function module</li> <li>• Auto refresh settings of an intelligent function module</li> </ul> <p>(4) To set X or Y as a refresh device Set a number later than the I/O numbers used for I/O modules and an intelligent function module.</p> <p>(5) Refresh timing Data are refreshed in the END process of a CPU module.</p>	<ul style="list-style-type: none"> <li>• Device M, L, B, T, C, ST, D, W, R, ZR (W for a head module)</li> <li>• Device number Within the device range of the CPU module or head module (Default: Blank)</li> </ul>
Ver.2 Remote Input (RX)	<p>When "Remote Net(Additional Mode)" is set in "Mode", set the start device where data in RX, RY, RWr, and RWw (Ver.2-compatible area) of the L series master/local module are transferred.</p>	Same as "Remote Input(RX)"
Ver.2 Remote Output (RY)	<p>When "Remote Net(Additional Mode)" is set in "Mode", set the start device where data in RX, RY, RWr, and RWw (Ver.2-compatible area) of the L series master/local module are transferred.</p>	Same as "Remote Output(RY)"
Ver.2 Remote Register (RWr)	<p>(1) Number of refresh points All points for the start station number to last station number of a Ver.2-compatible slave station are automatically assigned. (Refer to  Page 405, Appendix 2 (10) and Page 407, Appendix 2 (11).) To use a different refresh device for each station, transfer the data in the devices individually using a program (Un\G□ or FROM/TO instructions). The points for each station can be checked using Slave station offset, size information (Buffer memory address: 3E0<sub>H</sub> to 5DF<sub>H</sub>) (Refer to  Page 399, Appendix 2 (4).)</p>	Same as "Remote Register(RWr)"
Ver.2 Remote Register (RWw)	<p>The other contents are same as those for "Remote Input(RX)" described the above.</p>	Same as "Remote Register(RWw)"

7

7.4 Parameter Settings for a Local Station and Standby Master Station  
7.4.2 Setting details

Item	Description	Setting range
Special Relay (SB)	Set the start device where SB and SW are transferred. By setting these items, SB and SW can be automatically transferred to a device in a CPU module without a program.	<ul style="list-style-type: none"> <li>• Device M, L, B, D, W, R, SB, ZR (W and SB for a head module only)</li> <li>• Device number Within the device range of the CPU module or head module (Default: Blank)</li> </ul>
Special Register (SW)		<ul style="list-style-type: none"> <li>• Device M, L, B, D, W, R, SW, ZR (W and SW for a head module)</li> <li>• Device number Within the device range of the CPU module or head module (Default: Blank)</li> </ul>
Retry Count Automatic Reconnection Station Count Standby Master Station No. PLC Down Select Scan Mode Setting Delay Time Setting Station Information Setting Remote Device Station Initial Setting	The settings are not required when the L series master/local module is used as a local station or standby master station. (This does not apply when "Master Station (Duplex Function)" is selected in "Type").	—
Interrupt Settings	Set the conditions used to issue a request for the interrupt to a CPU module. (Refer to  Page 104, Section 7.4.2 (2).)	—

**(1) Operation setting**

Project window ⇨ [Parameter] ⇨ [Network Parameter] ⇨ [CC-Link] ⇨ [Operation Setting] button

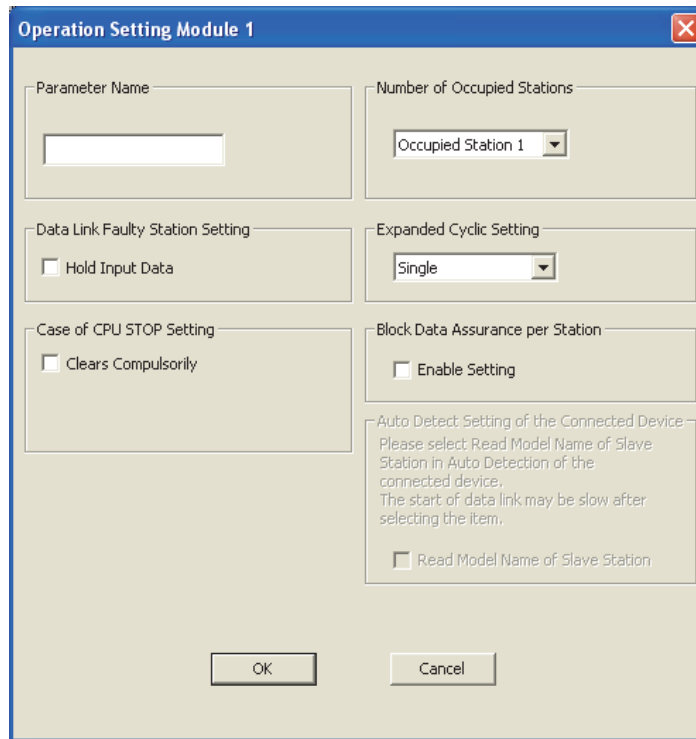

Item	Description	Setting range
Parameter Name	Set the parameter name. (Even if the parameter name is not set, this will not affect the operation of the CC-Link system).	8 characters (Default: Blank)
Data Link Faulty Station Setting	Select whether to clear or hold data input from a data link faulty station. (Refer to  Page 133, Section 8.2.4 and Page 136, Section 8.2.6.)	<ul style="list-style-type: none"> <li>• Clear input data (not checked)</li> <li>• Hold input data (checked)</li> </ul> (Default: Clear input data (not checked))
Case of CPU STOP Setting	Select whether to refresh or clear compulsorily output (sending) data to a slave station when the switch on a CPU module is set to STOP. (Refer to  Page 134, Section 8.2.5 and Page 136, Section 8.2.6.)	<ul style="list-style-type: none"> <li>• Refresh (not checked)</li> <li>• Clear compulsorily (checked)</li> </ul> (Default: Refresh (not checked))
Connected Devices Auto-detection Setting	The settings are not required when the L series master/local module is used as a local station or standby master station.	—
Number of Occupied Stations	Set the number of occupied local and standby master station.	<ul style="list-style-type: none"> <li>• Occupied Station 1</li> <li>• Occupied Station 2</li> <li>• Occupied Station 3</li> <li>• Occupied Station 4</li> </ul> (Default: Occupied Station 1)
Expanded Cyclic Setting	Select the expanded cyclic setting for the L series master/local module. Select the setting only for the following cases. <ul style="list-style-type: none"> <li>• When "Remote Net(Ver.2 Mode)" or "Remote Net(Additional Mode)" is set in "Mode"</li> <li>• When "Local Station" or "Standby Master Station" is set in "Type"</li> </ul>	<ul style="list-style-type: none"> <li>• Single</li> <li>• Double</li> <li>• Quadruple</li> <li>• Octuple</li> </ul> (Default: Single)
Block Data Assurance per Station	Select whether to assure the integrity of cyclic data for each slave station. (Refer to  Page 159, Section 8.2.9.)	<ul style="list-style-type: none"> <li>• Disable setting (not checked)</li> <li>• Enable setting (checked)</li> </ul> (Default: Disable setting (not checked))

7

7.4 Parameter Settings for a Local Station and Standby Master Station  
7.4.2 Setting details

## (2) Interrupt Settings

Project window ⇨ [Parameter] ⇨ [Network Parameter] ⇨ [CC-Link] ⇨ [Interrupt Settings] button

1. In the "Interrupt Settings" window, set the conditions on which the L series master/local module issues the interrupt to a CPU module.
2. Click the [End] button and close the setting window.

	Device Code	Device No.	Detection Method	Interrupt Condition	Word Device Setting Value	Channel No./Connection No.	Interrupt (SI) No.
1	RX	0000	Edge Detect	ON			0
2	RWr	0004	Level Detect	Unequal	150		1
3	Scan Completed						2
4							
5							
6							
7							
8							
9							
10							
11							
12							
13							
14							
15							
16							

Item	Description	Setting range
Input Format	Select the input format of "Word Device Setting Value".	<ul style="list-style-type: none"> <li>• DEC</li> <li>• HEX</li> </ul> (Default: DEC)
Device Code	Set the device for the interrupt condition.	Refer to the following table on the next page.
Device No.		
Detection Method		
Interrupt Condition		
Word Device Setting Value		
Channel No./Connection No.	The setting is not required for an L series master/local module.	
Interrupt (SI) No.	Set the interrupt (SI) No. used for the interrupt pointer setting of the PLC parameter.  The interrupt (SI) No. is the control number on the L series master/local module side to issue a request for the interrupt from the L series master/local module to a CPU module. (This is not a device used for an actual program.)	



Only one interrupt condition can be set for one interrupt program.

(Setting range)

If the interrupt condition is established upon completion of a link scan, the interrupt is issued. If "Scan Completed" is set in "Device Code", the interrupt is issued without condition upon completion of a link scan.

Device Code	Device No.	Detection Method	Interrupt Condition	Word Device Setting Value	Channel No./Connection No.	Interrupt (SI) No.
RX	0 to 1FFF(H)	Edge Detect + ON: Interrupt at rise		—		
SB	0 to 01FF(H)	Edge Detect + OFF: Interrupt at fall				
RY	0 to 1FFF(H)	Level Detect + ON: Interrupt at ON Level Detect + OFF: Interrupt at OFF				
RWr	0 to 07FF(H)	Edge Detect + Equal: Interrupt when the value is matched (first time only)		0 to 65535 (0(H) to FFFF(H))	—	0 to 15
SW	0 to 01FF(H)	Edge Detect + Unequal: Interrupt when the value is not matched (first time only)				
		Level Detect + Equal: Interrupt when the value is matched				
		Level Detect + Unequal: Interrupt when the value is not matched				
Scan Completed	—					

3. When the interrupt settings are completed, open the "Intelligent Function Module Interrupt Pointer Setting" window of the PLC parameter.  
Relate "Interrupt (SI) No." of the L series master/local module set in the "Interrupt Settings" window to the interrupt pointer of the CPU module.  
Project window ⇨ [Parameter] ⇨ [PLC Parameter] ⇨ "PLC System" tab ⇨ [Interrupt Pointer Setting] button
4. Input settings to the "Intelligent Function Module Interrupt Pointer Setting" window.
5. Click the [End] button and close the setting window.

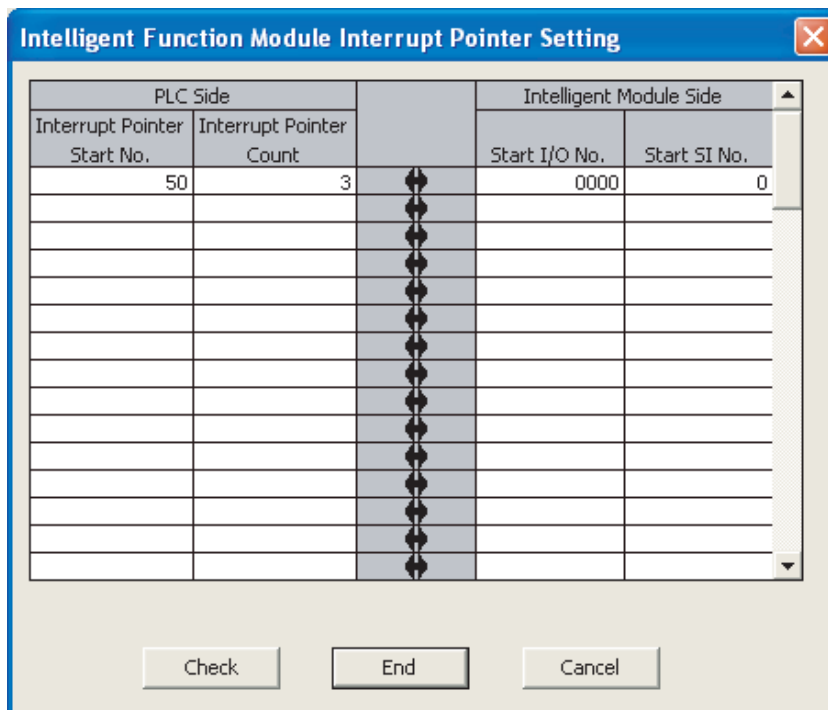

Item		Description	Setting range
PLC Side	Interrupt Pointer Start No.	Set the start number (I□□) of the interrupt pointer.	50 to 255 (Default: Blank)
	Interrupt Pointer Count	Set the number of the interrupt conditions set in the "Interrupt Settings" window of the network parameter.	1 to 16 (Default: Blank)
Intelligent Module Side	Start I/O No.	Set the start I/O number of the L series master/local module.	Within the range of I/O points of the CPU module (Default: Blank)
	Start SI No.	Set the start number of the SI No. set in "Interrupt (SI) No." in the "Interrupt Settings" window of the network parameter.	0 to 15 (Default: Blank)



## 7.5 Precautions on the Parameter Setting

### (1) Station number setting

The following explains how to set the station numbers for the master station and slave stations.

Specify the station numbers according to the following conditions.

- Set the station numbers not used for other stations. If a station number already in use is set, an error occurs.
- Set consecutive station numbers for stations in the same system. To set empty station numbers for future use, set the stations as reserved stations. Setting the stations as reserved stations prevents the stations from being detected as a faulty station. Set reserved stations in the master station using the network parameter of a programming tool. (☞ Page 83, Section 7.3.2 (2), Page 178, Section 8.3.4)
- When the number of occupied stations in a module is two or more, set the start station number.

**Ex** Station number setting in modules when the number of occupied stations is two or more

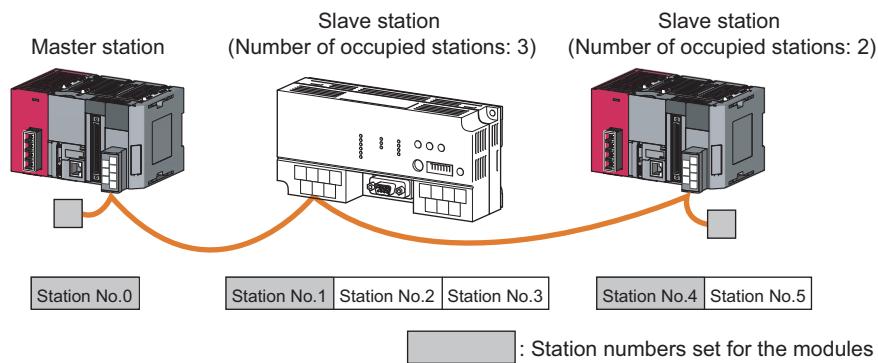

**Ex** Setting the station numbers 1 to 3 (number of occupied stations: 3) as reserved stations

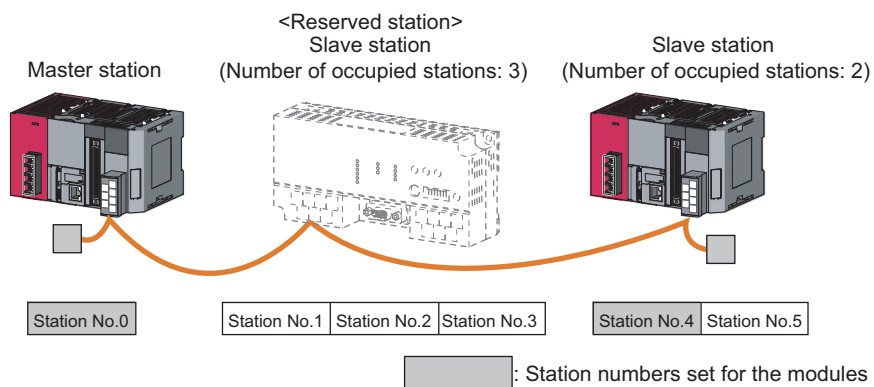

### Point

- If an empty station number is set without setting a reserved station, the station is detected as a faulty station in Other station data link status (SW0080 to SW0083).
- The station numbers need to be consecutive, but wiring does not need to be performed in the order of station number.

## (2) Transmission speed setting



For using the module as a local station or standby master station, the transmission speed can be set to "Auto-tracking".

In that case, no transmission speed setting error will occur because the local station or standby master station tracks the transmission speed of the master station automatically.

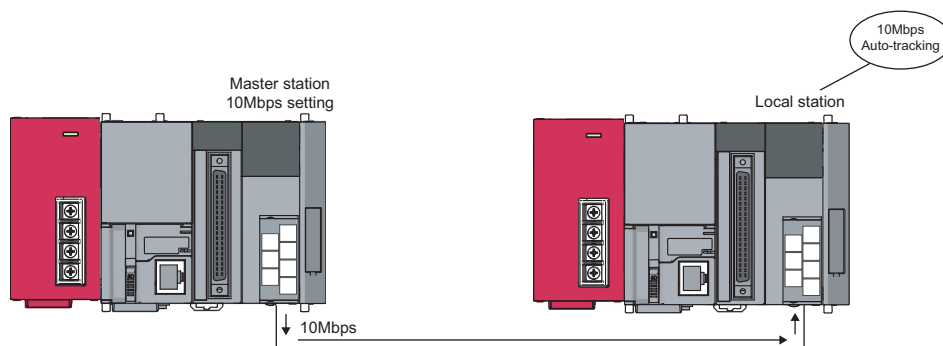
The transmission speed can be checked with the B RATE LED on the front of the module. (Refer to  Page 22, CHAPTER 2.)



### Point

- When the transmission speed is set to "Auto-tracking", it takes about five seconds for the transmission speed to be determined after powered on. This also applies when a station is reconnected to the network after disconnection. When the terminal block is installed or removed or line status becomes unstable during the power-on, it may takes five seconds or longer for the transmission speed to be established.
- The transmission speed that can be set varies depending on the total cable length. For details, refer to  Page 30, Section 3.2.2.
- Use the same transmission speed for all of the master station and slave stations. If the setting for even one of the stations is different, data link cannot function properly.
- To check whether the same transmission speed is set for all of the master station and slave stations, obtain the transmission speed settings in the loop test with GX Works2. (Refer to  Page 378, Section 15.4.2.)

## (3) Mismatch in the number of points between parameter-set expanded cyclic setting and installation status

If there is a mismatch in the number of points between the parameter-set expanded cyclic setting and installation status, the L series master/local module stores an error code into SW0069. Also, it stores the matching status of each station into SW009C to SW009F.

#### (4) Precautions on the mode between the master/local station and the standby master station

In any of the following cases, an error (error code: B3A0<sub>H</sub>) will occur at a local or standby master station.

If an error has occurred, correct the that for the master, local, or standby master station, and reset the CPU module.

- The mode set for the master station differs from that for the standby master station.
- When the master station is set to the remote net ver.1 mode, the local station is set to the remote net ver.2 mode or remote net additional mode.
- When the master station is set to the remote net ver.2 mode, the local station is set to the remote net additional mode.

#### (5) Automatic refresh setting

##### (a) By specifying refresh devices, automatic refresh is performed in the END process of the CPU module.

The automatic refresh covers the areas from the station No.1 to the last station No. set in the network parameter setting (including occupied stations).

##### (b) When the remote net additional mode is selected, data of the station No.1 to the last Ver.1-compatible station (including occupied stations) and data of Ver.2-compatible stations from its first station No. (the last Ver.1-compatible station No. +1) to the last station No. are automatically refreshed to devices specified in the first and last halves respectively.

##### (c) In the Ver.2-compatible remote register, data in the area up to the last remote device or intelligent device station No. are refreshed.

**Ex** The remote net additional mode, Ver.1-compatible station: No. 1 to 8, Ver.2-compatible station: No. 9 to 16 (occupying 1 station, quadruple setting), refresh devices (first half): Y1000, and refresh devices (last half): Y1100 are set

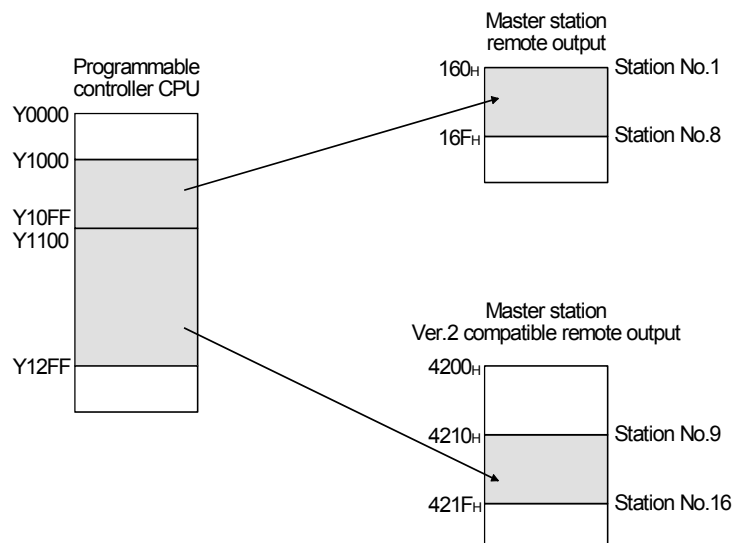

# CHAPTER 8 FUNCTIONS

This chapter explains the functions of the L series master/local module, dividing them into three sections: "Basic Functions", "Functions for Improving System Reliability" and "Handy Functions".

## 8.1 Basic Functions

This section explains the basic functions of the L series master/local module.

### 8.1.1 Communication with remote I/O stations

The following is an overview of the communication between the master station and a remote I/O station using the remote I/O net mode.

In the communication with the remote I/O station, the on/off data of the switches and indicator lamps are communicated through remote input RX and remote output RY.

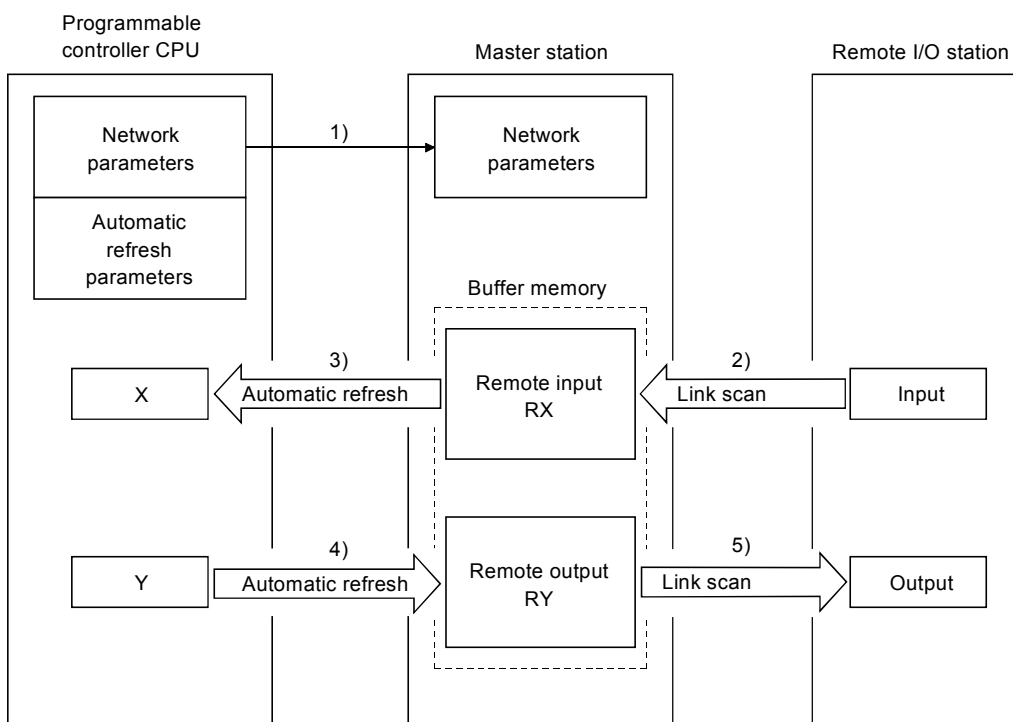

[Data link startup]

1. When the programmable controller system is powered on, the network parameters in the programmable controller CPU are transferred to the master station, and the CC-Link system automatically starts up.

[Remote input]

2. The input status of a remote I/O station is stored automatically (for each link scan) in the master station's "remote input RX" buffer memory.
3. The input status stored in the "remote input RX" buffer memory is stored in the CPU device set with the automatic refresh parameters.

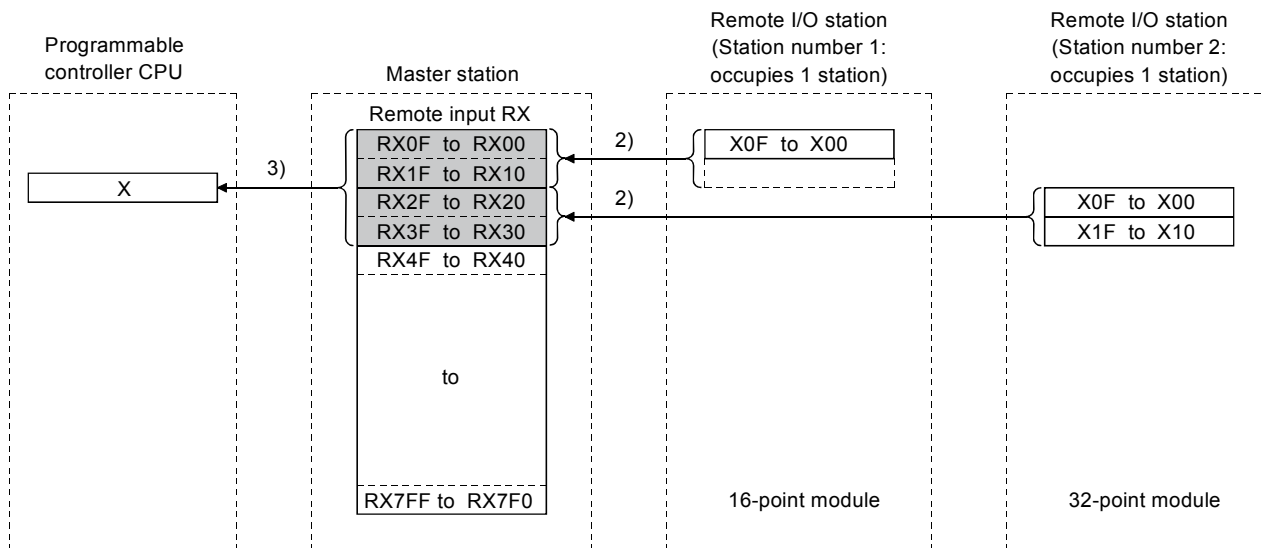

[Remote output]

4. The on/off data of the CPU device set with the automatic refresh parameters is stored in the "remote output RY" buffer memory.
5. The output status stored in the "remote output RY" buffer memory is output automatically (for each link scan) to remote I/O stations.

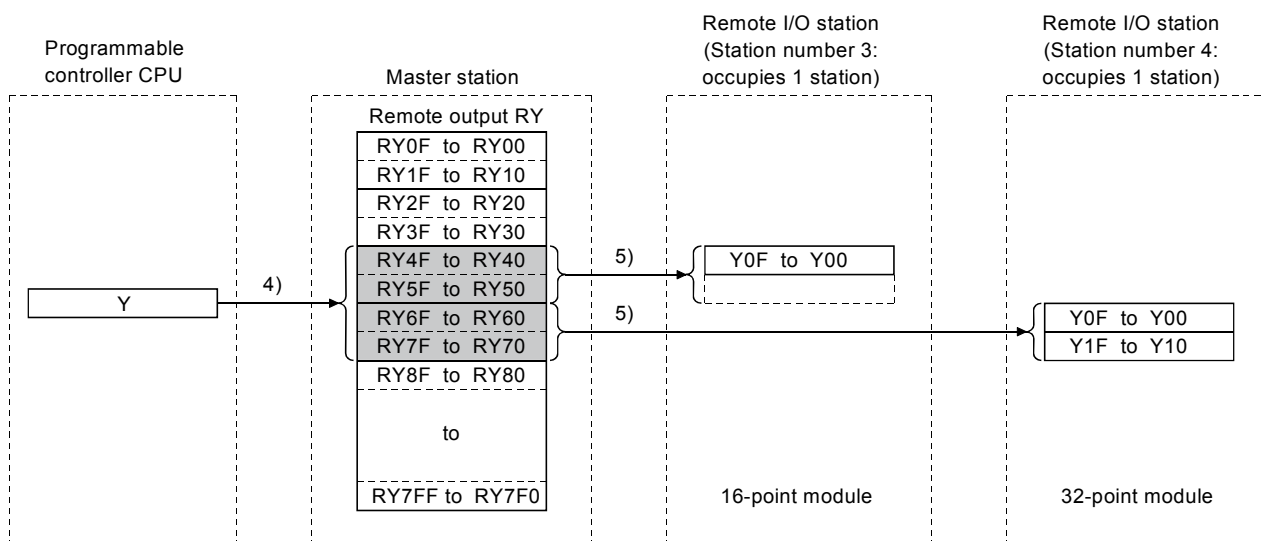

 **WARNING**

- When setting the automatic refresh parameters, it is recommended to specify "Y" as the remote output RY refresh device. If any device other than "Y" (e.g. M or L) is specified, parameter setting must be made to compulsorily clear the device status at a CPU STOP. If parameter setting is not made, the device status before a STOP is retained as is.

For slave station compulsory clear in case of CPU STOP, refer to  Page 134, Section 8.2.5.

## 8.1.2 Communication with remote device stations

This section explains an overview of the communication between the master and remote device stations. In the communication with remote device stations, the signals for handshaking with remote device stations (initial data request flag, error reset request flag, etc.) are communicated using remote input RX and remote output RX. Numeric data (averaging processing specification, digital output value, etc.) is communicated using remote register RWw and remote register RWr.

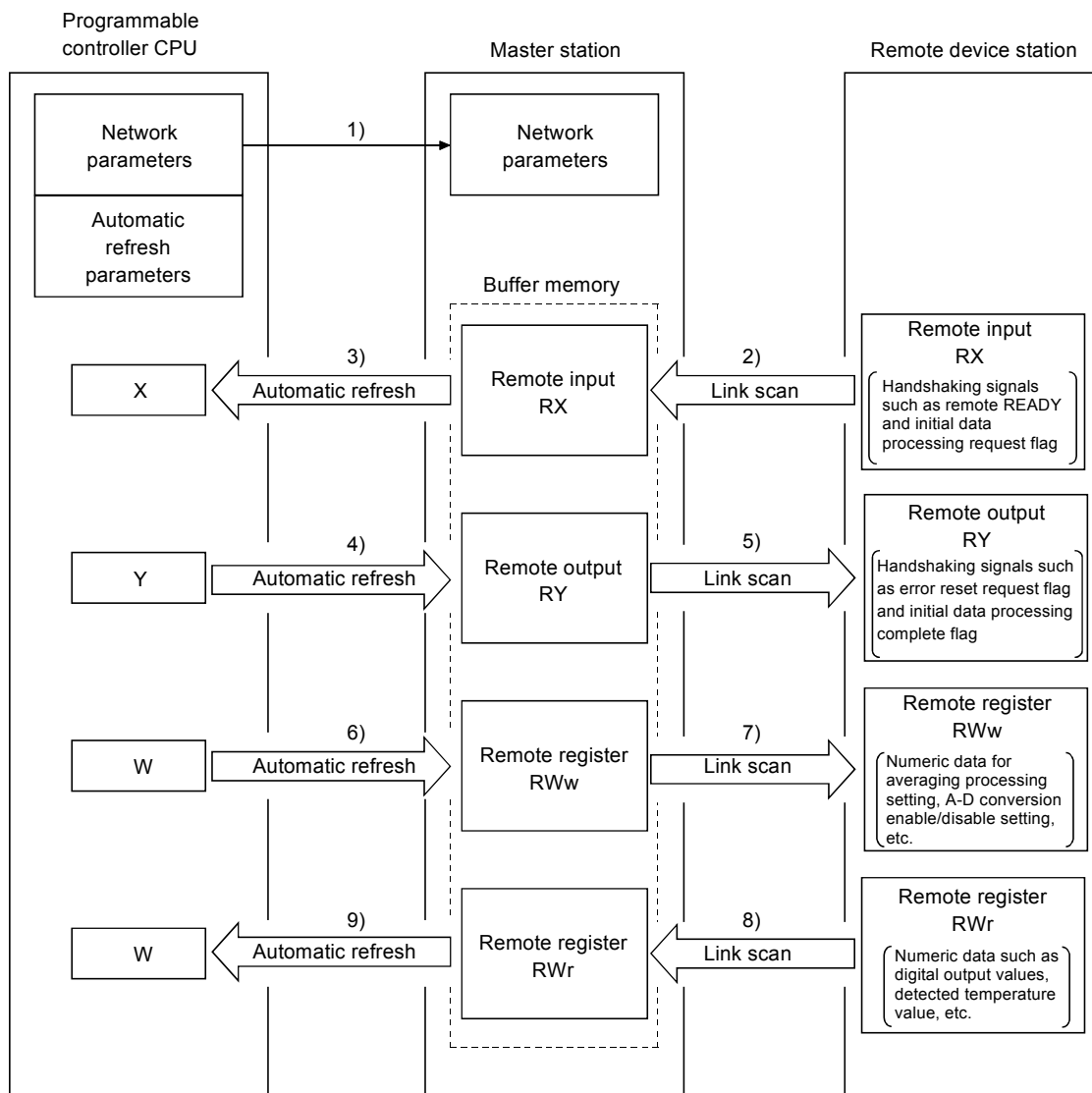

[Data link startup]

1. When the programmable controller system is powered on, the network parameters in the programmable controller CPU are transferred to the master station, and the CC-Link system automatically starts up.

[Remote input]

2. The remote input RX of a remote device station is stored automatically (for each link scan) in the master station's "remote input RX" buffer memory.
3. The input status stored in the "remote input RX" buffer memory is stored in the CPU device set with the automatic refresh parameters.

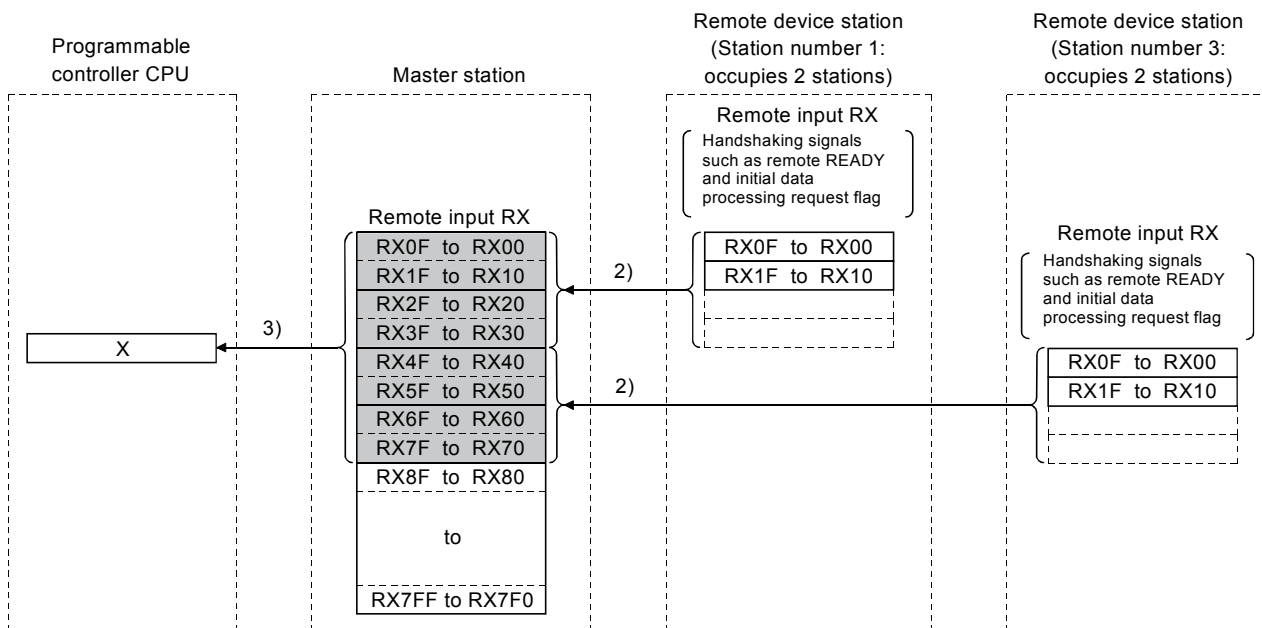

[Remote input RX when the AJ65BT-64AD is set to station number 1]

Signal direction: AJ65BT-64AD → Master module	
Device No.	Signal name
RX00	CH1 A-D conversion completed flag
RX01	CH2 A-D conversion completed flag
RX02	CH3 A-D conversion completed flag
RX03	CH4 A-D conversion completed flag
RX04	Not used
⋮	
RX17	
RX18	Initial data processing request flag
RX19	Initial data setting complete flag
RX1A	Error status flag
RX1B	Remote READY
RX1C	Not used
⋮	
RX1F	



[Remote output]

4. The on/off data of the CPU device set with the automatic refresh parameters is stored in the "remote output RY" buffer memory.
5. Remote output RY is automatically set to on/off (for each link scan) according to the output status stored in the "remote output RY" buffer memory.

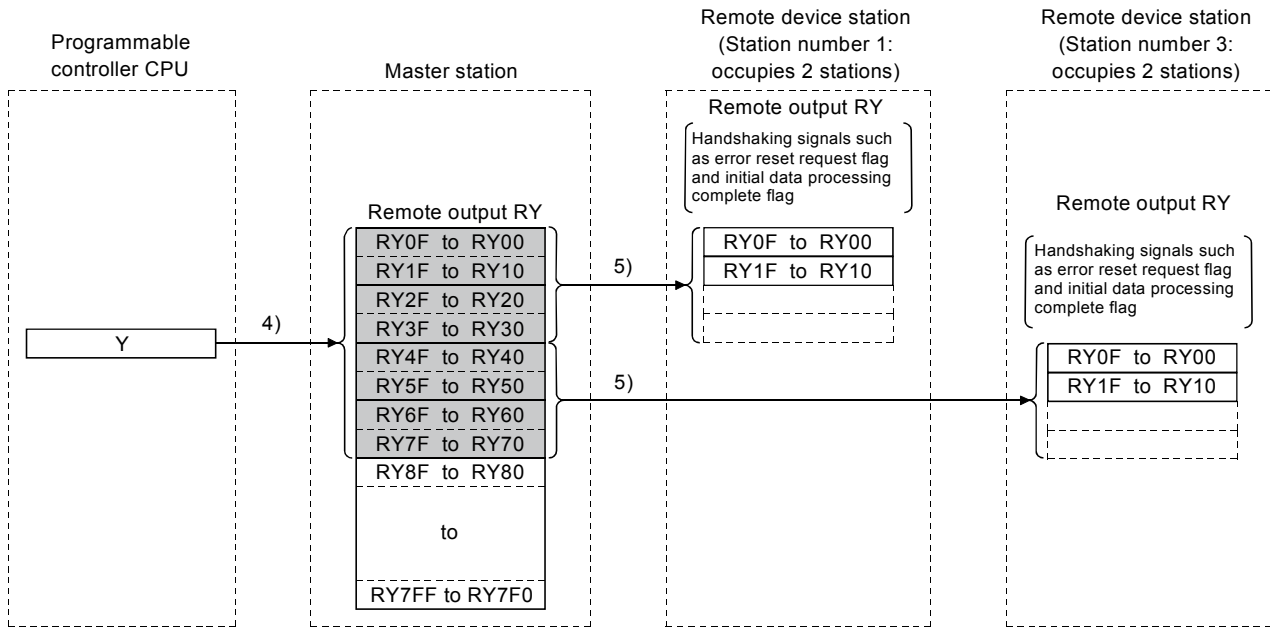

[Remote output RY when the AJ65BT-64AD is set to station number 1]

Signal direction: Master module → AJ65BT-64AD	
Device No.	Signal name
RY00	Selection of offset/gain values
RY01	Selection of voltage/current
RY02	Not used
⋮	
RY17	
RY18	Initial data setting complete flag
RY19	Initial data setting request flag
RY1A	Error reset request flag
RY1B	Not used
⋮	
RY1F	

[Writing to the remote register RWw]

6. The transmission data of the CPU device set with the automatic refresh parameters is stored in the "remote register RWw" buffer memory.
7. The data stored in the "remote register RWw" buffer memory is automatically sent to the remote register RWw of each remote device station.

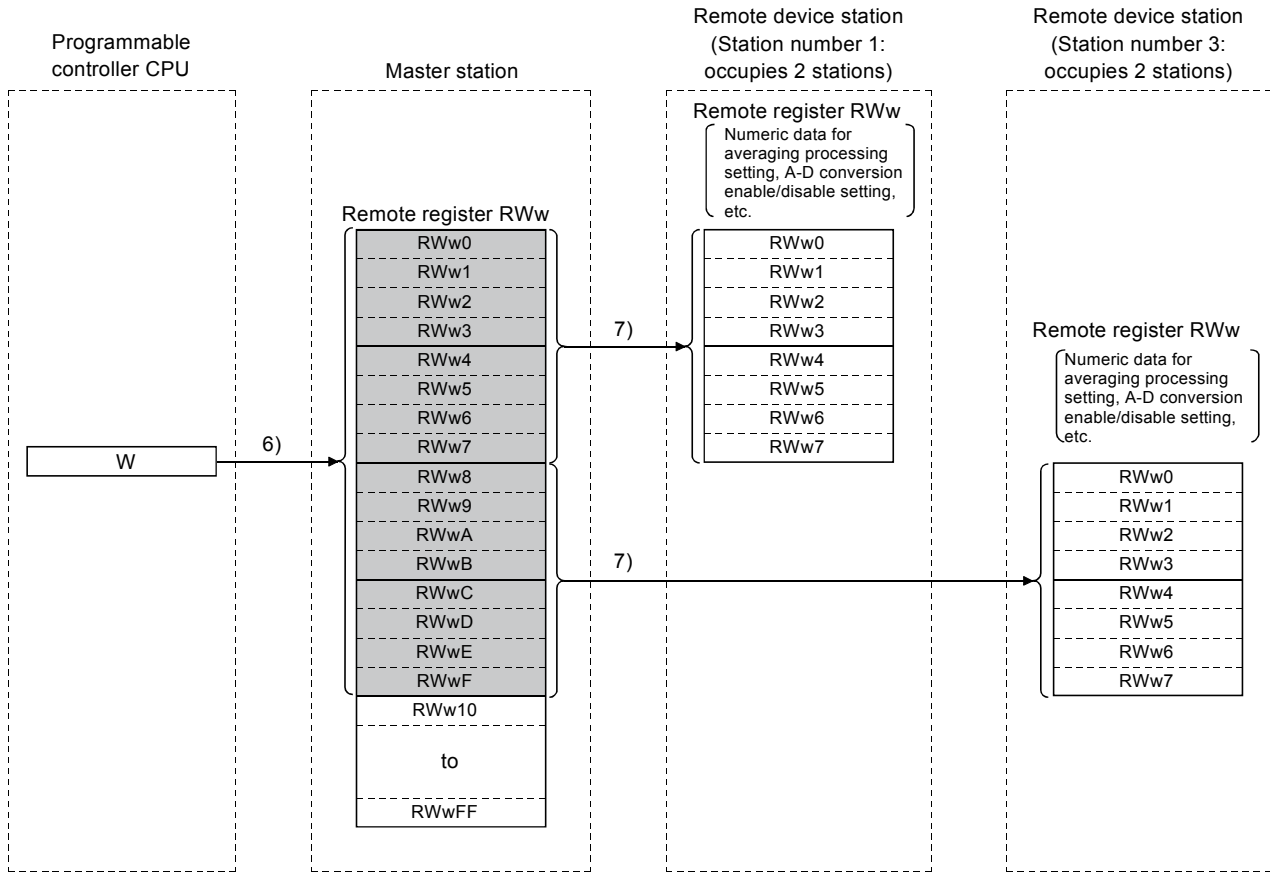

[Remote register RWw when the AJ65BT-64AD is set to station number 1]

Signal direction: master module → AJ65BT-64AD	
Address	Description
RWw0	Averaging process setting
RWw1	CH1 average time, number of times
RWw2	CH2 average time, number of times
RWw3	CH3 average time, number of times
RWw4	CH4 average time, number of times
RWw5	Data format
RWw6	A-D conversion enable/disable setting
RWw7	Not used

\* The data to be written to the remote registers RWw0 to RWwn is predefined for each remote device station.

[Reading from the remote register (RWr)]

- 8. The remote register RWr data of a remote device station is automatically stored in the "remote register Rwr" buffer memory of the master station.
- 9. The remote register RWr data of a remote device station stored in the "remote register RWr" buffer memory is stored in the CPU device set with the automatic refresh parameters.

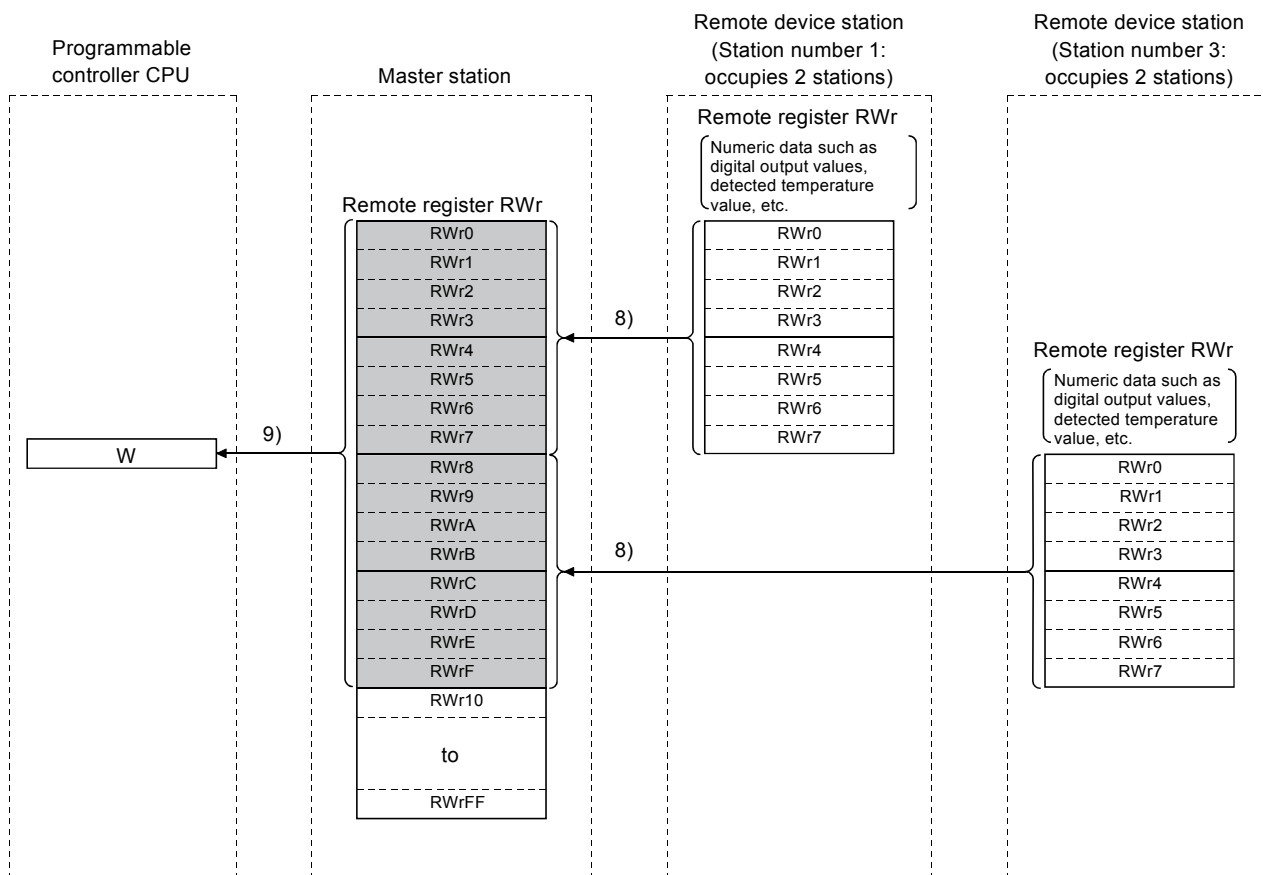

[Remote register RWr when the AJ65BT-64AD is set to station number 1]

Signal direction: AJ65BT-64AD → Master module	
Address	Description
RWr0	CH1 digital output value
RWr1	CH2 digital output value
RWr2	CH3 digital output value
RWr3	CH4 digital output value
RWr4	Error code
RWr5	Not used
RWr6	
RWr7	

# 8.1.3 Communication with local stations

This section explains an overview of the communication between the master and local stations.

## (1) Communication between the master and local stations by cyclic transmission

Data communication between programmable controller CPUs can be performed in N:N mode using remote input RX and remote output RY (bit data used in local station systems) as well as remote register RWw and remote register RWr (word data for writing and reading used in local station systems).

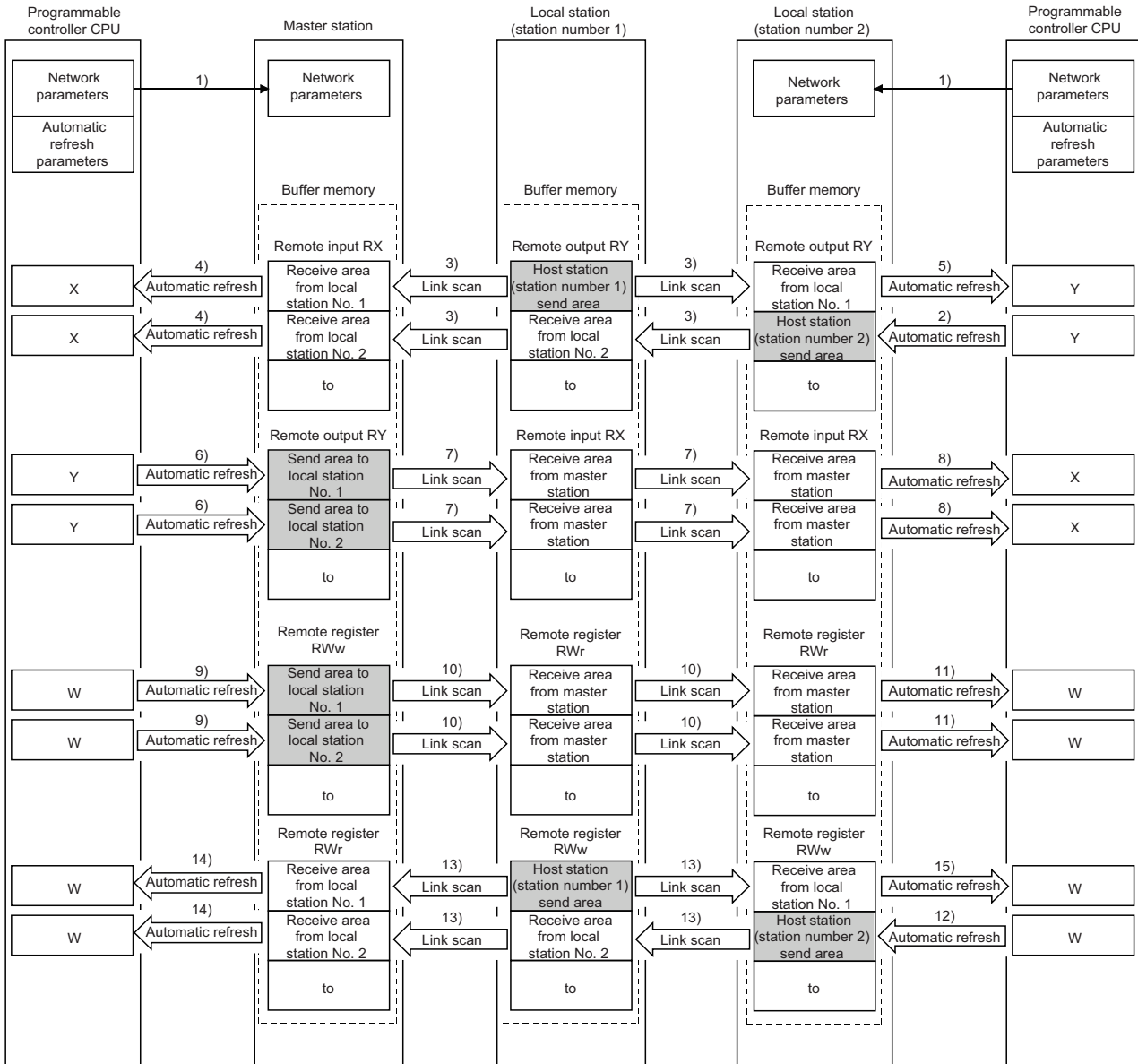

The master station sends only the data for the stations that are performing data link.  
The data for the stations that are not performing data link are not sent.

[Data link startup]

1. When the programmable controller system is powered on, the network parameters in the programmable controller CPU are transferred to the master station and the CC-Link system starts up automatically.

[On/off data from a local station to the master station or other local stations]

2. The on/off data of the CPU device set with the automatic refresh parameters is stored in the "remote output RY" buffer memory of the local station. The remote output RY is used as output data in local station systems.
3. The data in the "remote output RY" buffer memory of the local station is automatically stored (for each link scan) in the "remote input RX" buffer memory of the master station and the "remote output RY" buffer memory of other local stations.
4. The input status stored in the "remote input RX" buffer memory is stored in the CPU device set with the automatic refresh parameters. The remote input RX is used as input data in local station systems.
5. The input status stored in the "remote output RY" buffer memory is stored in the CPU device set with the automatic refresh parameters.

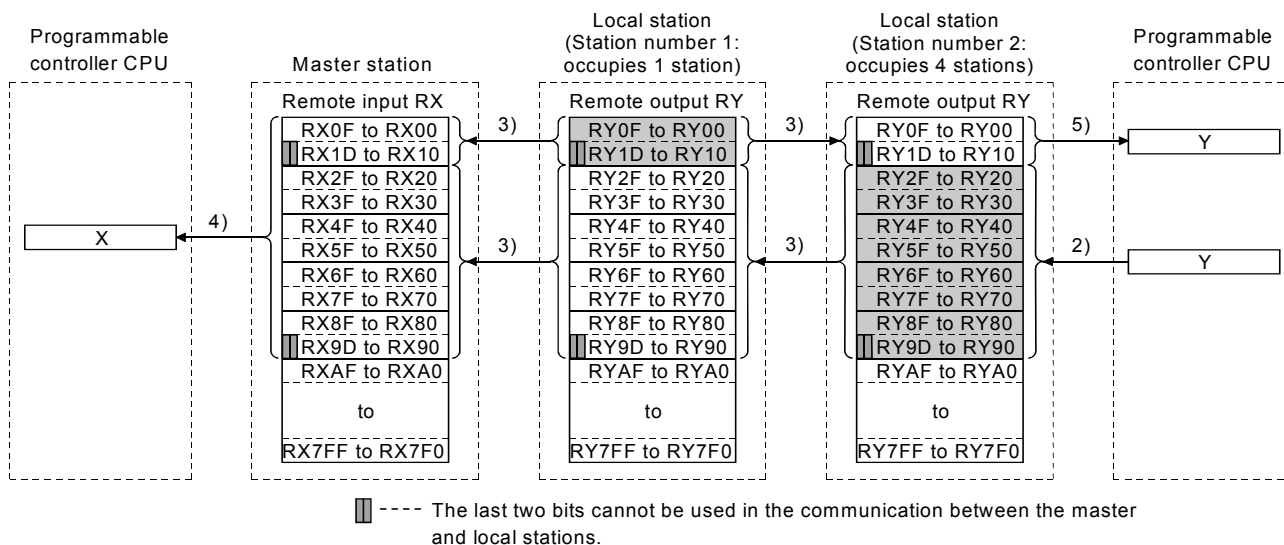

[On/off data from the master station to local stations]

6. The on/off data of the CPU device set with the automatic refresh parameters is stored in the "remote output RY" buffer memory of the master station.
7. The data in the "remote output RY" buffer memory is stored automatically (for each link scan) in the "remote input RX" buffer memory of the local station.
8. The input status stored in the buffer memory "remote input RX" is stored in the CPU device set with the automatic refresh parameters.

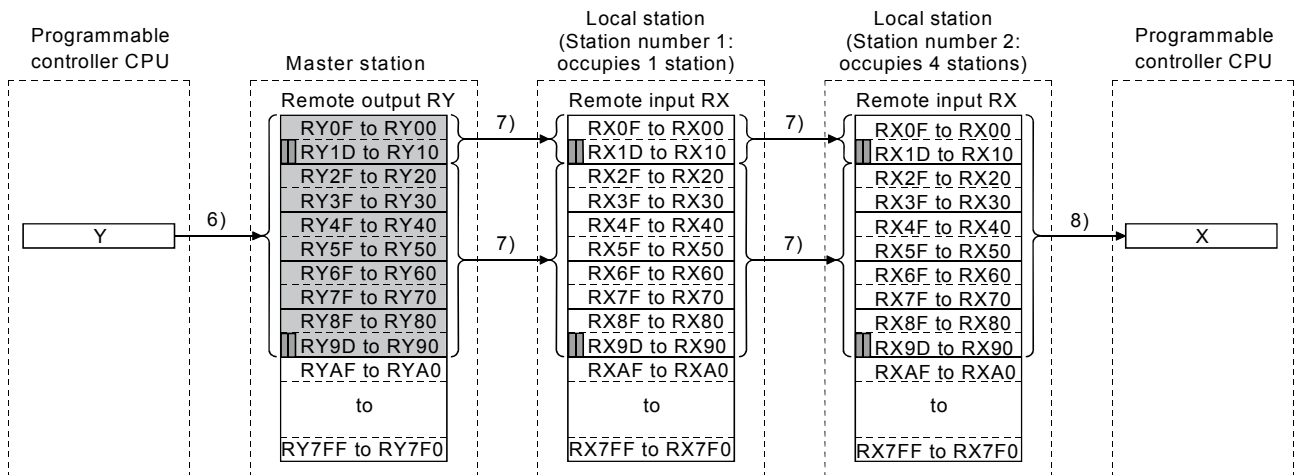

▬ ---- The last two bits cannot be used in the communication between the master and local stations.

[Word data from the master station to all local stations]

- 9.** The word data of the CPU device set with the automatic refresh parameters is stored in the "remote register RWw" buffer memory of the master station.  
The remote register RWw is used as word data for writing in local station systems.
- 10.** The data in the buffer memory "remote register RWw" is stored automatically (for each link scan) in the buffer memory "remote register RWr" of all local stations.  
The remote register RWr is used as word data for reading in local station systems.
- 11.** The word data stored in the buffer memory "remote register RWr" is stored in the CPU device set with the automatic refresh parameters.

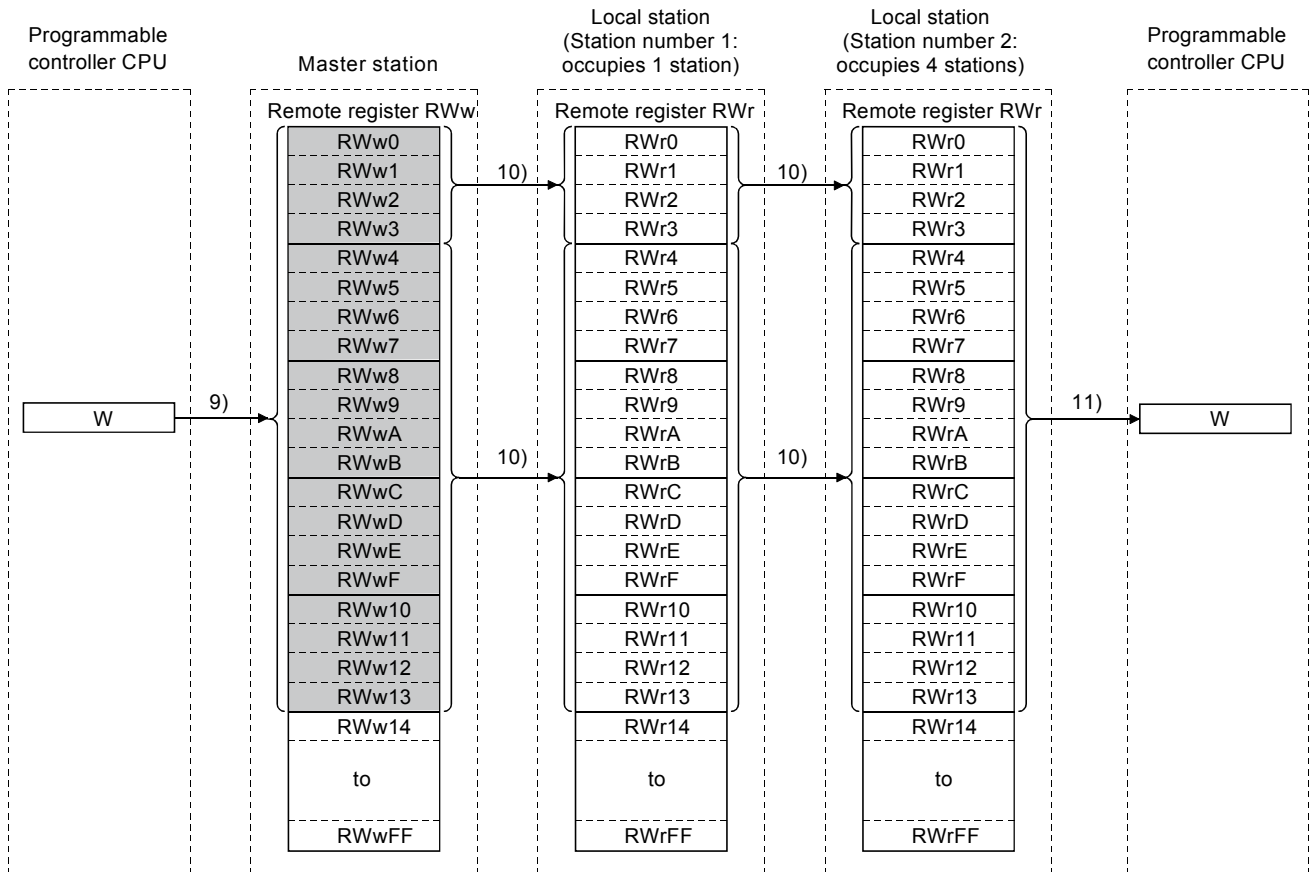

[Word data from a local station to the master and other local stations]

- 12.** Word data set with the automatic refresh parameters is stored in the "remote register RWw" buffer memory of the local station.  
However, the data is stored only in the area corresponding to its own station number.
- 13.** The data in the "remote register RWw" buffer memory is stored automatically (for each link scan) in the "remote register RWr" of the master station and the "remote register RWw" of other local stations.
- 14.** The word data stored in the "remote register RWr" buffer memory is stored in the CPU device set with the automatic refresh parameters.
- 15.** The word data stored in the "remote register RWw" buffer memory is stored in the CPU device set with the automatic refresh parameters.

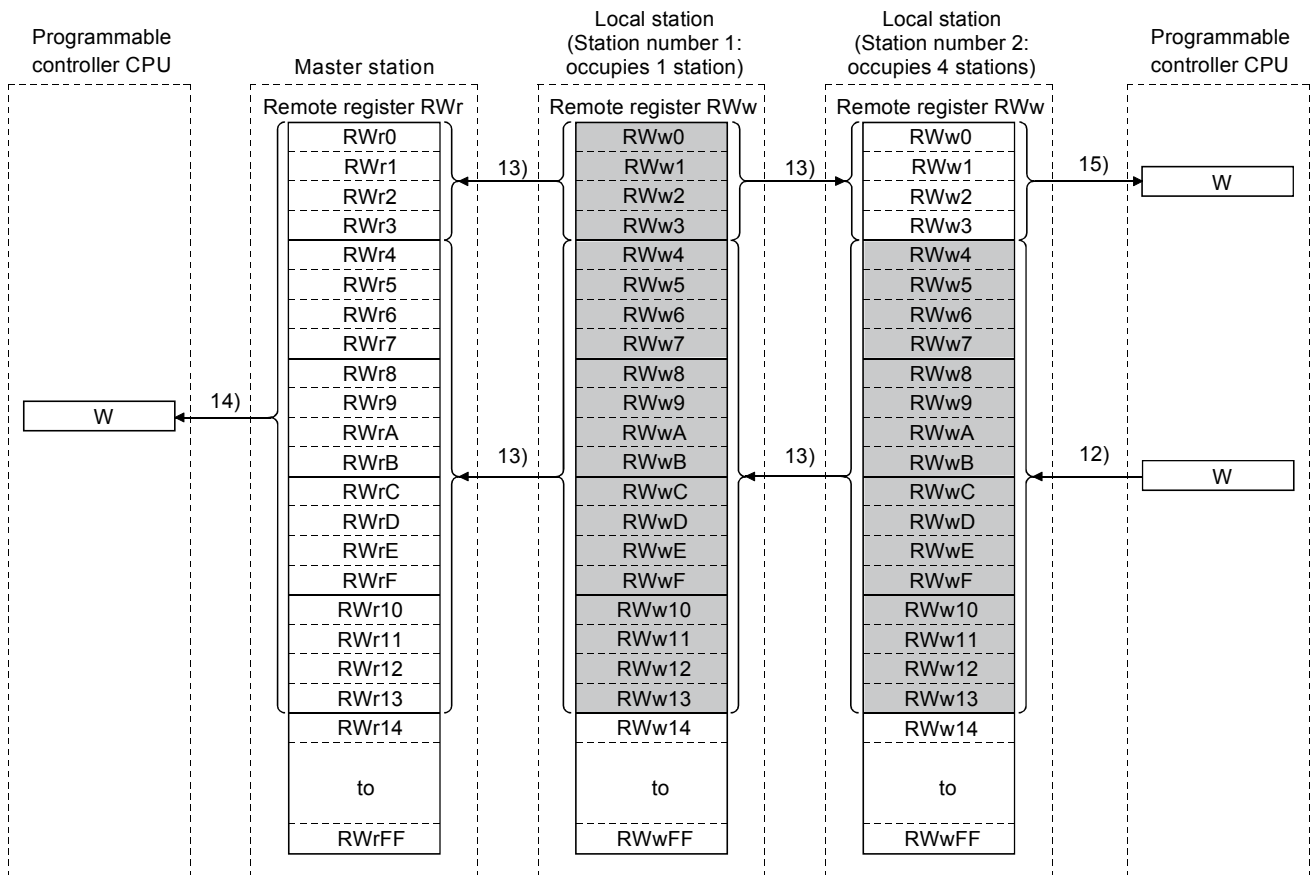



## (2) Communication between the master and local stations by transient transmission

Transient transmission is one of the transmission methods, and by which data are sent or received at any timing on a one-to-one basis (1:1) by specifying the target.

[Writing data to the buffer memory in a local station using the G(P).RIWT instruction]

1. Data to be written to the buffer memory in a local station is stored in the send buffer in the master module.
2. The data is written to the buffer memory in the local station.
3. The local station returns a writing complete response to the master station.
4. The devices specified with the G(P).RIWT instruction are turned on.

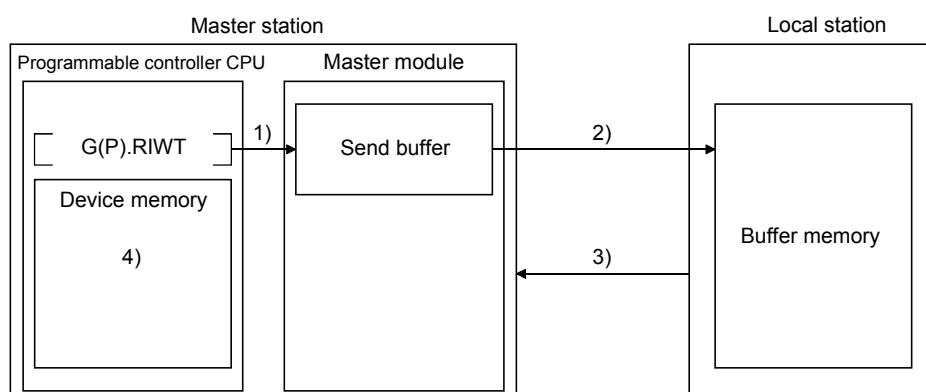

[Reading data from the buffer memory in a local station using the G(P).RIRD instruction]

1. The data in the buffer memory of the local station is accessed.
2. The data read is stored in the receive buffer of the master station.
3. The data is stored in the device memory of the programmable controller CPU and the devices specified with the G(P).RIRD instruction are turned on.

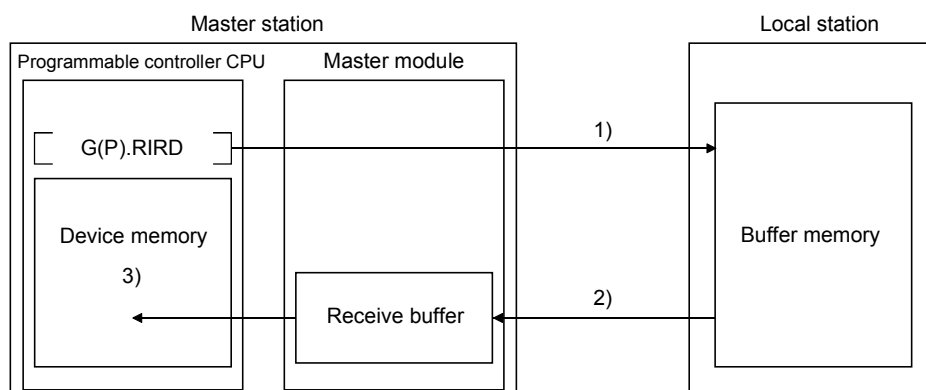

### Point

Before performing data communication using transient transmission, the sizes of the send and receive buffers must be set up in the buffer memory of the master station.

For details on setting the sizes of the send and receive buffers, refer to  Page 83, Section 7.3.2 (2).

## 8.1.4 Communication with intelligent device stations

This section explains an overview of the communication between the master and intelligent device stations.

### (1) Communication between the master station and intelligent device stations by cyclic transmission

Handshaking signals with intelligent device stations (positioning complete, positioning start. etc.) are sent or received using remote input RX and remote output RX.

Numeric data (positioning start number, present feed value, etc.) is sent or received using remote register RWw and remote register RWr.

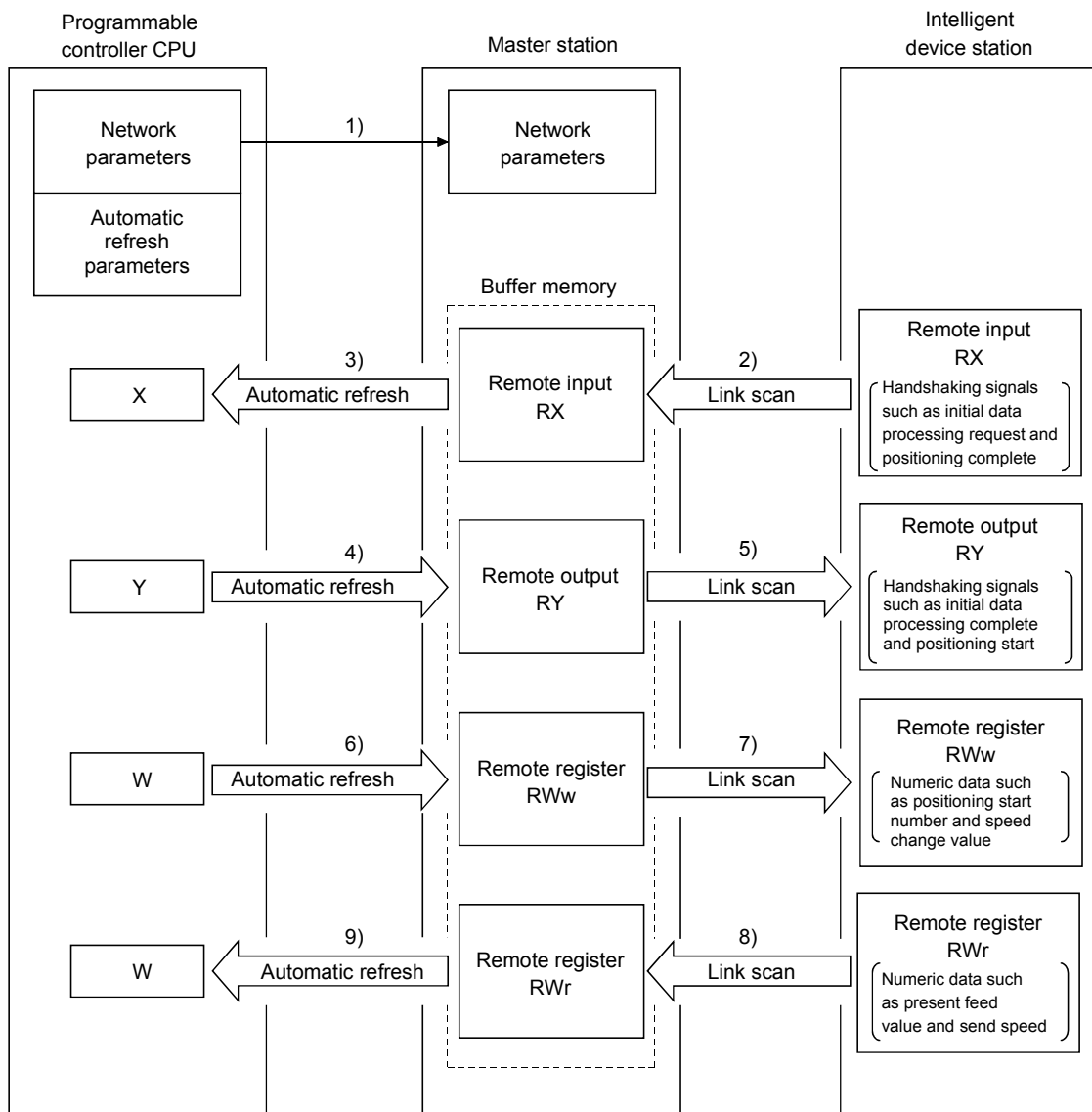

[Data link startup]

1. When the programmable controller system is powered on, the network parameters in the programmable controller CPU are transferred to the master station, and the CC-Link system automatically starts up.

[Remote input]

2. The remote input RX of an intelligent device station is stored automatically (for each link scan) in the master station's "remote input RX" buffer memory.
3. The input status stored in the "remote input RX" buffer memory is stored in the CPU device set with the automatic refresh parameters.

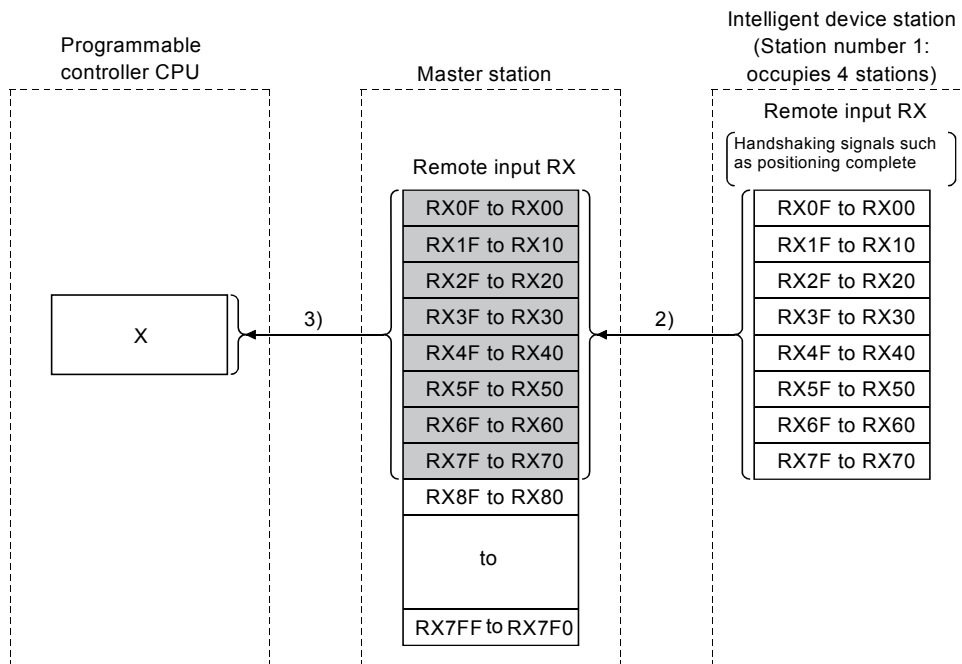

[Remote input RX when the AJ65BT-D75P2-S3 is set to station number 1]

Signal direction: AJ65BT-D75P2-S3 → Master module	
Device No.	Signal name
RX00	D75P2 ready complete
RX01	Single-axis start complete
RX02	Dual-axis start complete
RX03	Use prohibited
RX04	Single-axis BUSY
RX05	Dual-axis BUSY
RX06	Use prohibited
RX07	Single-axis positioning complete
RX08	Dual-axis positioning complete
⋮	⋮

[Remote output]

4. The on/off data of the CPU device set with the automatic refresh parameters is stored in the "remote output RY" buffer memory.
5. Remote output RY of the intelligent device station is automatically set to on/off (for each link scan) according to the output status stored in the "remote output RY" buffer memory.

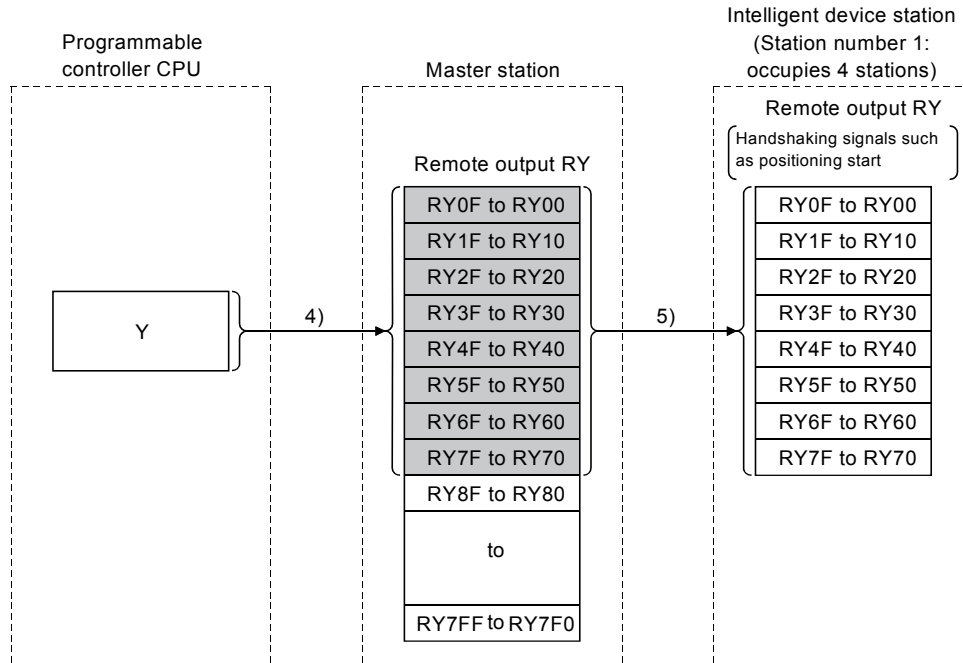

[Remote output RY when the AJ65BT- D75P2-S3 is set to station number 1]

Signal direction: AJ65BT-D75P2-S3 → Master module	
Address	Description
RY01	Use prohibited
⋮	
RY0F	
RY10	Single-axis positioning start
RY11	Dual-axis positioning start
RY12	Use prohibited
RY13	Single-axis stop
RY14	Dual-axis stop
⋮	⋮

[Writing to the remote register (RWw)]

6. The transmission data of the CPU device set with the automatic refresh parameters is stored in the "remote register RWw" buffer memory.
7. The data stored in the "remote register RWw" buffer memory is automatically sent to the remote register RWw of the intelligent device station.

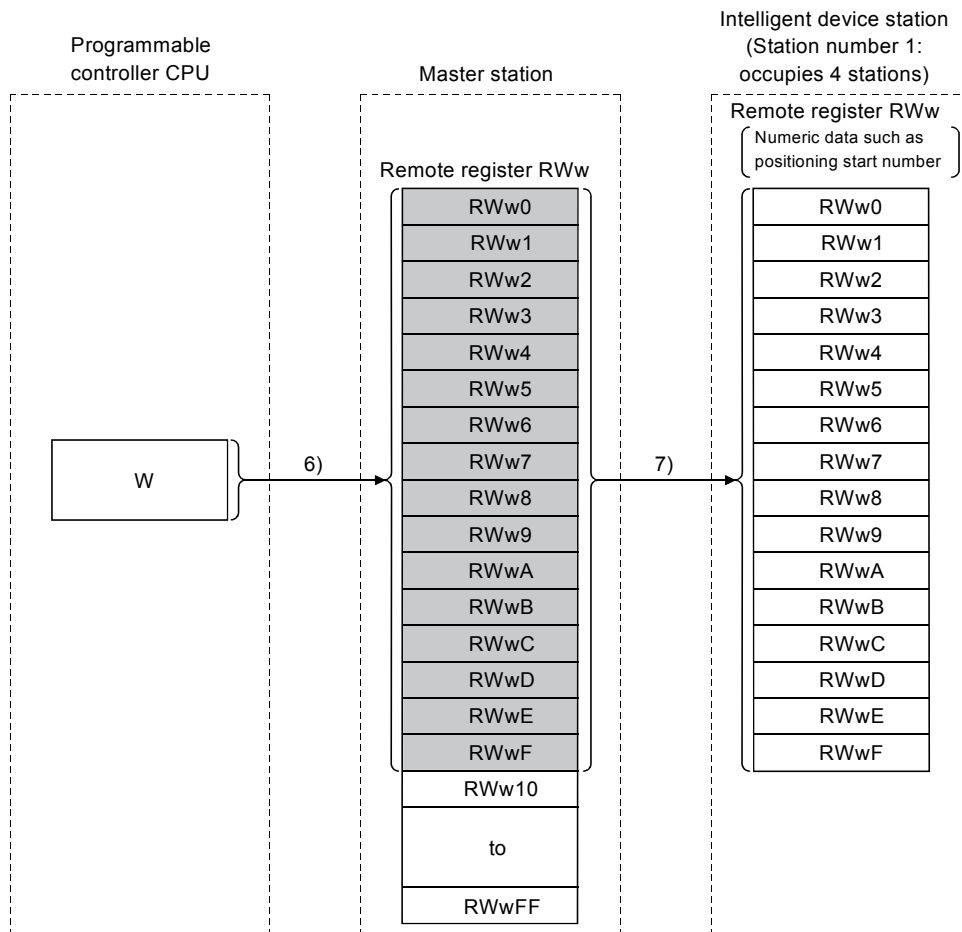

[Remote register RWw when the AJ65BT-D75P2-S3 is set to station number 1]

Signal direction: Master module → AJ65BT-D75P2-S3	
Address	Description
RWw0	Single-axis positioning start number
RWw1	Single-axis override
RWw2	Single-axis new present value
RWw3	
RWw4	Single-axis new speed value
RWw5	
RWw6	Single-axis JOG speed
RWw7	
⋮	⋮

\* The data to be written to the remote registers RWw0 to RWwn is predefined for each intelligent device station.

[Reading from the remote register (RWr)]

- 8. The remote register RWr data of the intelligent device station is automatically stored in the "remote register Rwr" buffer memory of the master station.
- 9. The remote register RWr data of the intelligent device station stored in the "remote register RWr" buffer memory is stored in the CPU device set with the automatic refresh parameters.

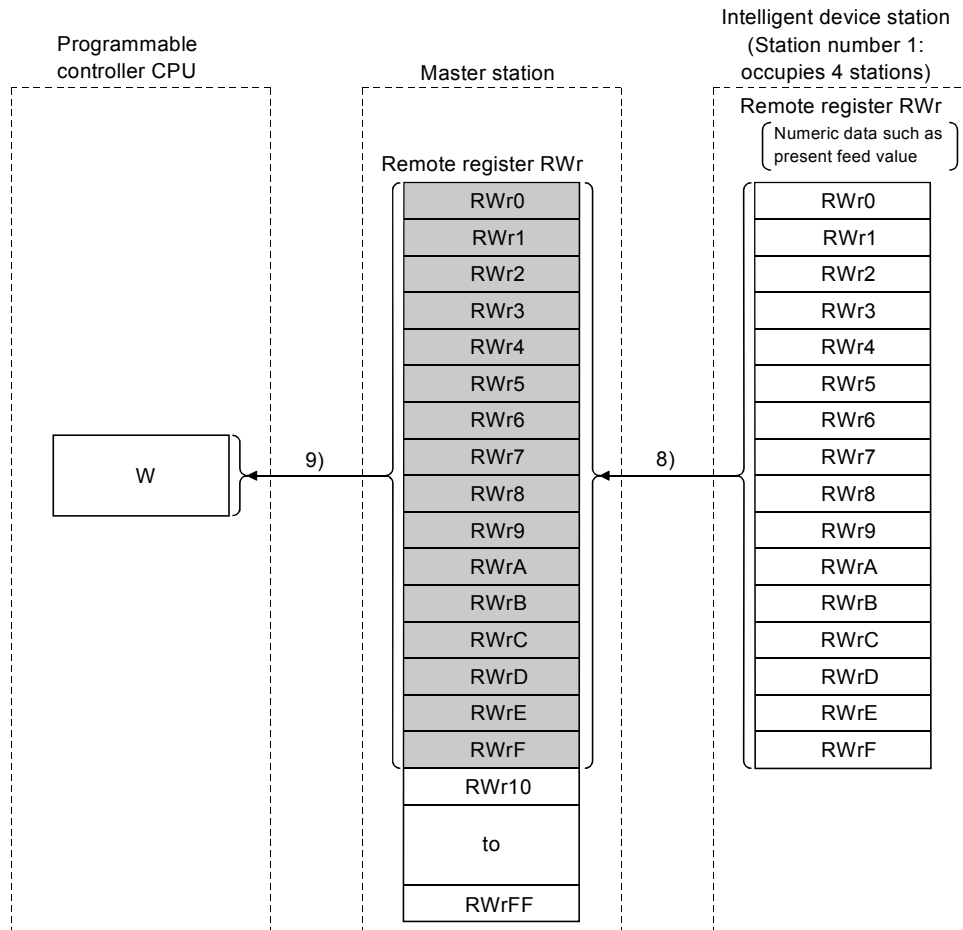

[Remote register RWr when the AJ65BT-D75P2-S3 is set to station number 1]

Signal direction: AJ65BT-D75P2-S3 → Master module	
Address	Description
RWr0	Single-axis present feed value
RWr1	
RWr2	Single-axis feed speed
RWr3	
RWr4	Single-axis valid M code
RWr5	Single-axis error number
RWr6	Single-axis warning number
RWr7	Single-axis operating status
⋮	⋮

## (2) Communication between the master and intelligent device stations by transient transmission

Transient transmission is one of the transmission methods, and by which data are sent or received at any timing on a one-to-one basis (1:1) by specifying the target.

[Writing data to the buffer memory in the intelligent device station using the G(P).RIWT instruction]

1. Data to be written to the buffer memory in an intelligent device station is stored in the send buffer in the master module.
2. The data is written to the buffer memory in the intelligent device.
3. The intelligent device returns a writing complete response to the master station.
4. The devices specified with the G(P).RIWT instruction are turned on.

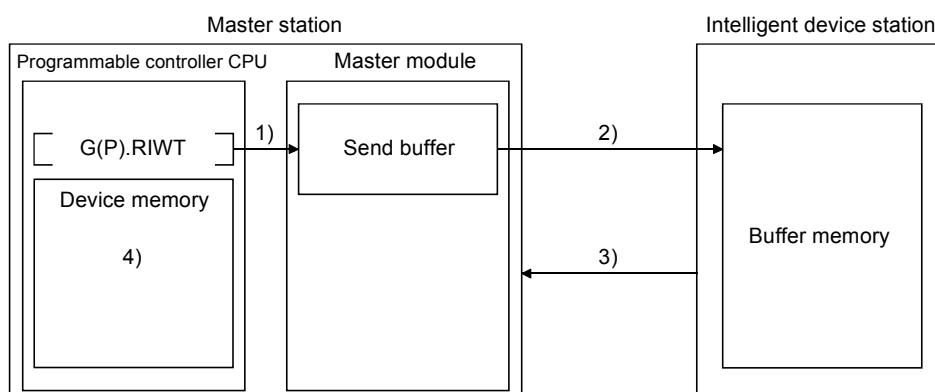

[Reading data from the buffer memory in the intelligent device station using the G(P).RIRD instruction]

1. The data in the buffer memory of an intelligent device station is accessed.
2. The data read is stored in the receive buffer of the master station.
3. The data is stored in the device memory of the programmable controller CPU and the devices specified with the G(P).RIRD instruction are turned on.

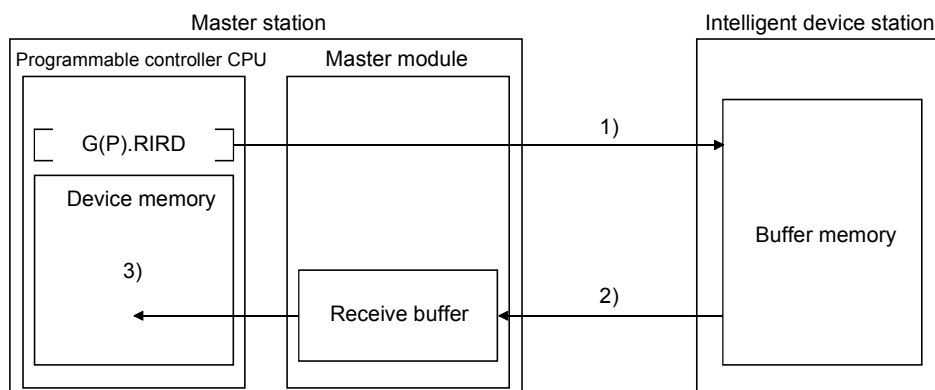

### Point

Before performing data communication using transient transmission, the sizes of the send and receive buffers must be set up in the buffer memory of the master station.

For details on setting the sizes of the send and receive buffers, refer to  Page 83, Section 7.3.2 (2).

## 8.2 Functions for Improving System Reliability

This section explains the functions for improving the reliability of the CC-Link system.

### 8.2.1 Slave station cut-off function

This function disconnects a slave station that has gone down due to a cause such as power off, and continues the data link among only normal slave stations (no setting is required).

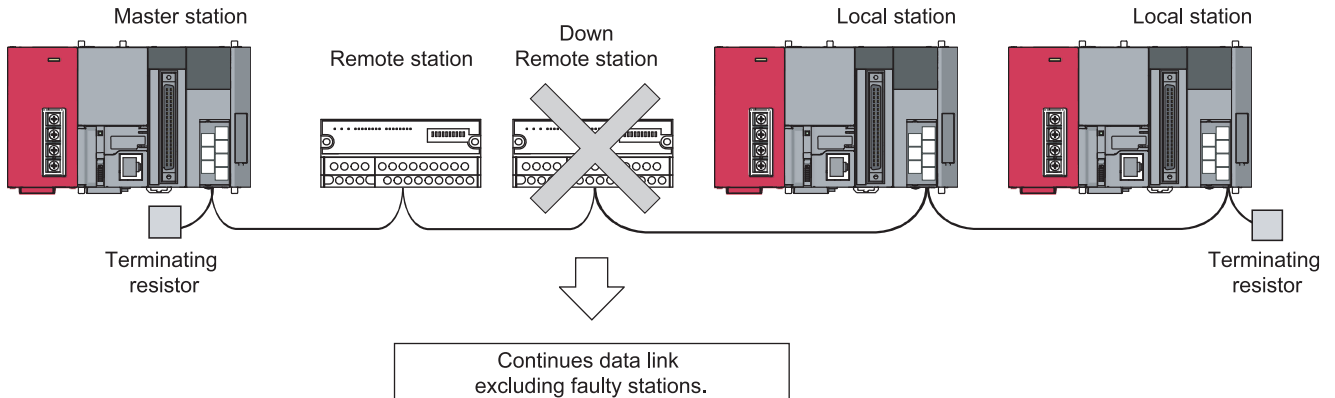

#### Point

In the event of cable disconnection, the data link cannot be performed because there is no terminating resistor ("ERR." LED turns on).

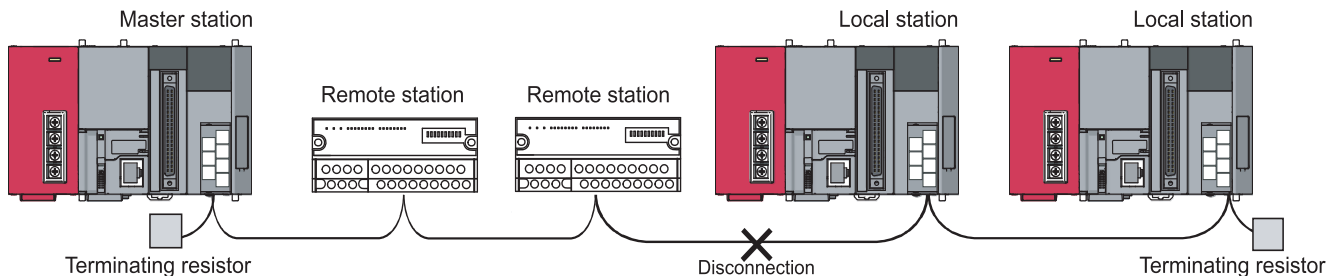



## 8.2.2 Automatic return function

---

This function allows a slave station that has been disconnected from the data link due to a cause such as power off to be automatically reconnected to the data link when it returns to the normal status.

[Setting method]

Set a value for "Automatic Reconnection Station Count" in the network parameter setting of GX Works2. (Refer to

 Page 77, Section 7.3.2 and Page 99, Section 7.4.2.)

## 8.2.3 Data link status setting in case of master station programmable controller CPU failure

---

This function sets the data link status (stop/continue) in case that an "error that stops the operation" occurs in the master station programmable controller CPU when the system does not have a standby master station.

When it is set to "continue", the data link among local stations can be continued.

For the status of each station at error occurrence, refer to  Page 136, Section 8.2.6.

### **Point**

---

- The data link continues when the master station programmable controller CPU falls into an "error that stops the operation".
  - With a standby master station setting, the data link will not continue when the master station programmable controller CPU is down even if the data link status at CPU down is set to "Continue". The standby master function overrides the setting and the data link control is switched to the standby master station.
- 

[Setting method]

Specify "PLC Down Select" in the network parameter setting of GX Works2. (Refer to  Page 77, Section 7.3.2 and Page 99, Section 7.4.2.)

## 8.2.4 Setting the status of input data from a data link faulty station

This function sets whether to clear or retain the input data (remote input (RX)) from data link faulty stations.

For the status of each station at error occurrence, refer to  Page 136, Section 8.2.6.

### (1) Target input (receiving) data

The following shows the applicable buffer memory areas.

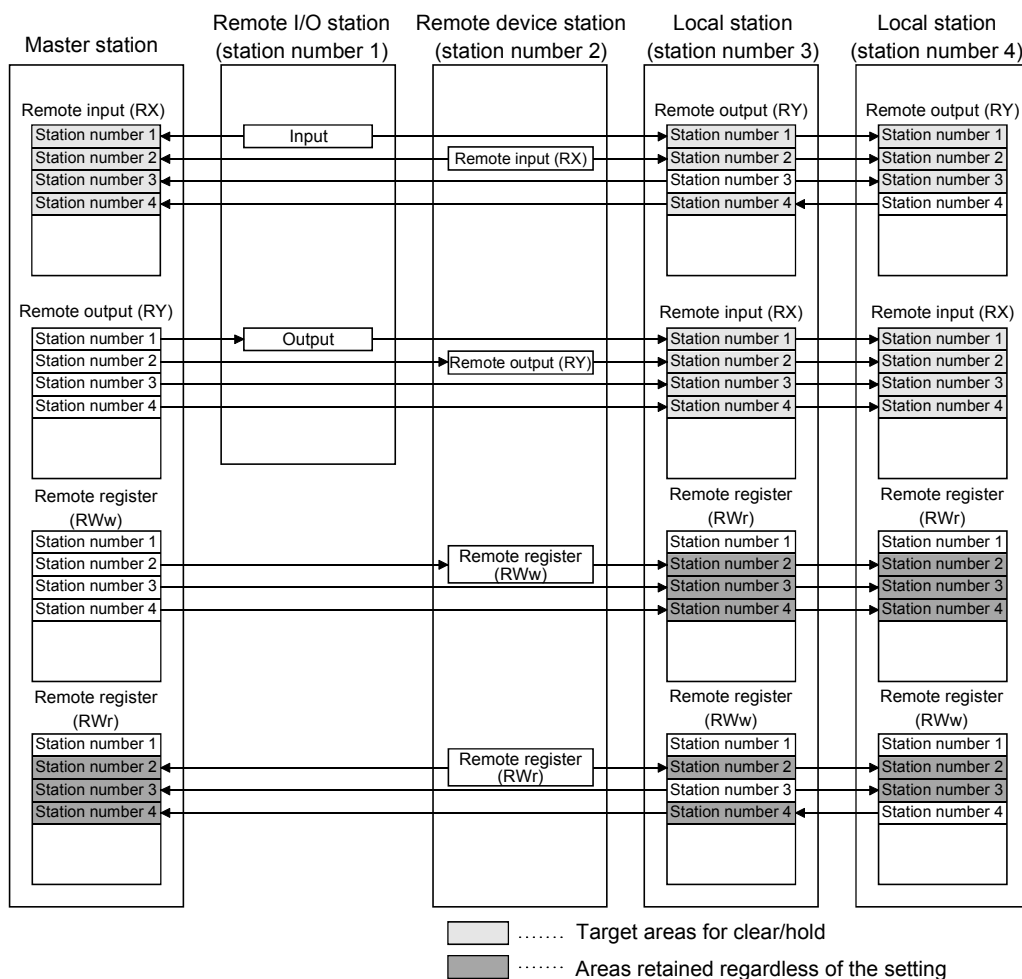

The remote input RX in the master station and the remote input RX and remote output RY in local stations either clear or retain data from faulty stations according to the setting.

The remote register RWr in the master station and the remote register RWw and remote register RWr in local stations retain data from faulty stations regardless of the setting.

### Point

When the data link faulty station is set as an error invalid station, input data (remote input RX) from that station is retained regardless of the setting.

### (2) Setting method

Set a mode in "Operation Setting" - "Data Link Faulty Station Setting" in the network parameter setting of GX Works2. (Refer to  Page 82, Section 7.3.2 (1) and Page 103, Section 7.4.2 (1).)

## 8.2.5 Slave station refresh/compulsory clear setting in case of programmable controller CPU STOP

This function forcibly clears the output data (remote output RY) to slave stations when the programmable controller CPU comes to STOP.

Remote output RY refresh device setting in the automatic refresh parameter dialog box provides the following choices.

- When "Y" is specified, the remote output RY is cleared regardless of the parameter setting.
- When specifying any device other than "Y" (e.g. M or L), make parameter setting to specify whether to refresh or forcibly clear the remote output RY.

For the status of each station at error occurrence, refer to  Page 136, Section 8.2.6.

### (1) Target output (send) data

The following shows the applicable buffer memory areas.

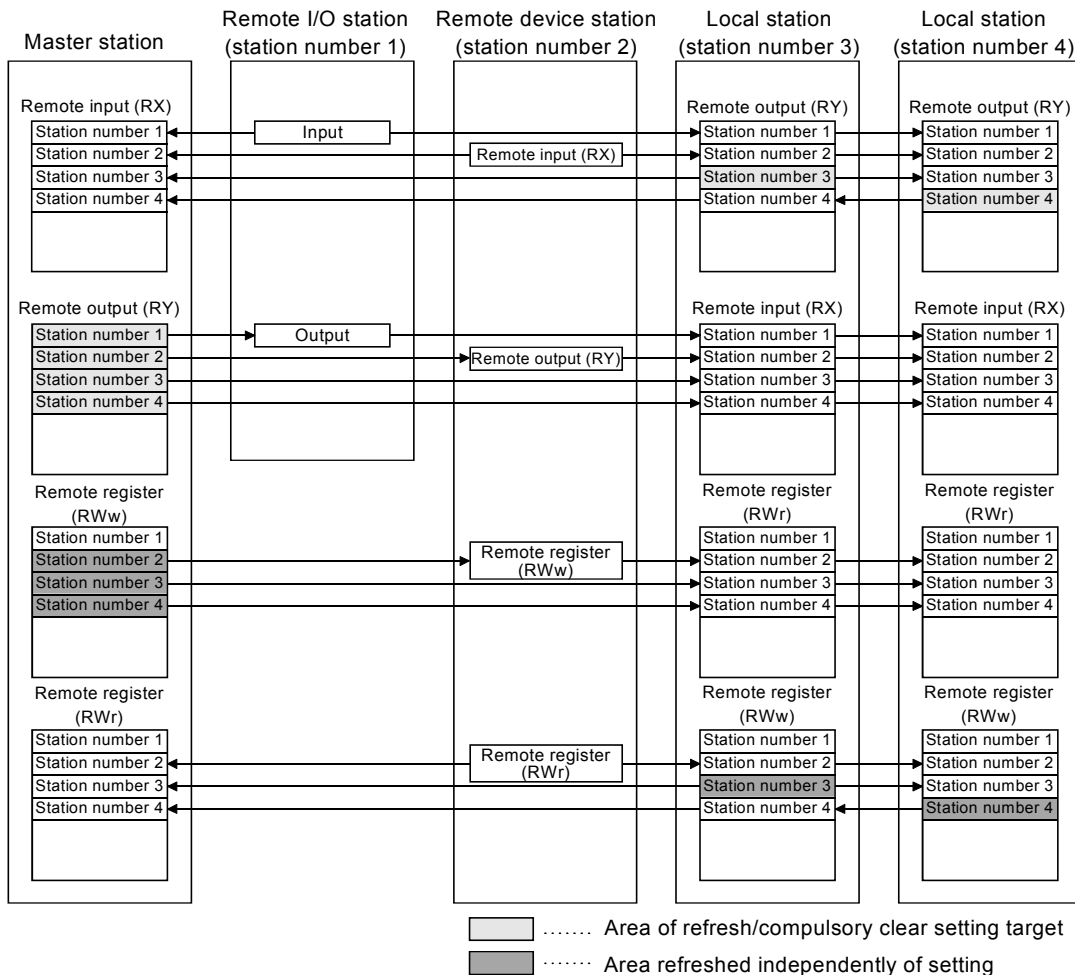

The remote output RY is refreshed or compulsorily cleared according to the setting when the programmable controller CPUs for the master and local stations come to STOP.

The remote input RX, remote register RWw and remote register RWr are refreshed regardless of the setting when the programmable controller CPUs for the master and local stations come to STOP.

**Point** 

- Selecting the compulsory clear option disables compulsory output to slave stations at CPU STOP using GX Works2.
- This setting is also valid when the TO instruction is used for RY refresh.

**(2) Setting method**

Set a mode in "Operation Setting" - "Case of CPU STOP Setting" in the network parameter setting of GX Works2.

(Refer to  Page 82, Section 7.3.2 (1) and Page 103, Section 7.4.2 (1).)

## 8.2.6 Station status at error occurrence

This section explains the status of each station that is set in network parameter's "PLC Down Select" and "Operation Setting" in case of error occurrence. (Refer to  Page 132, Section 8.2.3, Page 133, Section 8.2.4 and Page 134, Section 8.2.5.)

### (1) Status of the master station, standby master station (acting as a master station) and remote I/O station at error occurrence

The following shows the operations of the master station, standby master station (acting as a master station) and remote I/O station upon the occurrence of an error.

Data link status		Master station, standby master station (acting as a master station)				Remote I/O station		
		Remote input (RX)	Remote output (RY)	Remote register (RWw)	Remote register (RWr)	Input	Output	
When data link is stopped due to an error generated by the master station programmable controller CPU (data link continue)		Continue	*1	Continue	Hold	Continue	*1	
When data link is stopped due to an error generated by the local station programmable controller CPU (data link continue)		*2	Continue	Continue	Continue	Continue	Continue	
When data link for the entire system is stopped	The GX Works2 data link faulty station is set (master station setting)	Clear	Clear	Undefined	Undefined	Hold	By external signals	All points OFF
		Hold	Hold					
When a communication error (power off, etc.) occurs in a remote I/O station	The GX Works2 data link faulty station is set (master station setting)	Clear	Clears the receive area from the remote I/O station having a communication error	Continue	Continues operation of areas other than the remote I/O station	Continues operation of areas other than the remote I/O station	By external signals	All points OFF
		Hold	Retains the receive area from the remote I/O station with a communication error					
When a communication error (power off, etc.) occurs in a remote device station	The GX Works2 data link faulty station is set (master station setting)	Clear	Clears the receive area from the remote device station with a communication error	Continue	Continue	Retains the receive area from the remote device station with a communication error	Continue (Not affected by the communication status of the remote device station)	Continue (Not affected by the communication status of the remote device station)
		Hold	Retains the receive area from the remote device station with a communication error.					

Data link status			Master station, standby master station (acting as a master station)				Remote I/O station	
			Remote input (RX)	Remote output (RY)	Remote register (RWw)	Remote register (RWr)	Input	Output
When a communication error (power off, etc.) occurs in a local station	The GX Works2 data link faulty station is set (master station setting)	Clear	Clears the receive area from the local station with a communication error	Continue	Continue	Retains the receive area from the local station with a communication error	Continue (Not affected by the communication status of the local station)	Continue (Not affected by the communication status of the local station)
		Hold						

\*1 If parameter setting has been made using the dedicated instructions, the data is held. If parameter setting has been made using GX Works2, the data is cleared when the RY refresh device is set to Y, the data is cleared or held when the RY refresh device is set to other than Y. (Refer to  Page 134, Section 8.2.5.)

\*2 When the RY refresh device is set to "Y" for the local station that has stopped, only the receive area is cleared from the stopped local station ; the receive area is retained or cleared when the RY refresh device is set to other than Y. (Refer to  Page 134, Section 8.2.5.)

Operation continues for the receive areas from other stations.



## (2) Status of the remote device station, local station, standby master station (acting as a local station) and intelligent device station at error occurrence

The following shows the status of the remote device station, local station, standby master station (acting as a local station) and intelligent device station at error occurrence.

Data link status			Remote device station, intelligent device station				Local station, standby master station (acting as a local station)			
			Remote input (RX)	Remote output (RY)	Remote register (RWw)	Remote register (RWr)	Remote input (RX)	Remote output (RY)	Remote register (RWw)	Remote register (RWr)
When data link is stopped due to an error generated by the master station programmable controller CPU (data link continue)			Continue	*1	Continue	Continue	Clear	Continue	Continue	Continue
When data link is stopped due to an error generated by the local station programmable controller CPU (data link continue)			Continue	Continue	Continue	Continue	Continue	*2	Continue	Continue
When data link for the entire system is stopped	The GX Works2 data link faulty station is set (local station setting)	Clear	Undefined	All points OFF	Undefined	Undefined	Clear	Retains the receive areas from other stations	Retains the receive area from other stations	Hold
		Hold					Hold			
When a communication error (power off, etc.) occurs in a remote I/O station	The GX Works2 data link faulty station is set (local station setting)	Clear	Continue	Continue	Continue	Continue	Clear	Retains the receive area from a remote I/O station with a communication error	Continue	Continue
		Hold					Hold			
When a communication error (power off, etc.) occurs in a remote device station	The GX Works2 data link faulty station is set (local station setting)	Clear	Undefined	Undefined	Undefined	Undefined	Clear	Retains the receive area from a remote device station with a communication error	Retains the receive area from a remote device station with a communication error	Continue
		Hold					Hold			



Data link status			Remote device station, intelligent device station				Local station, standby master station (acting as a local station)			
			Remote input (RX)	Remote output (RY)	Remote register (RWw)	Remote register (RWr)	Remote input (RX)	Remote output (RY)	Remote register (RWw)	Remote register (RWr)
When a communication error (power off, etc.) occurs in a local station	The GX Works2 data link faulty station is set (local station setting)	Clear	Continue	Continue	Continue	Continue	Continue	Clears the receive area from a local station with a communication error	Retains the receive area from a local station with a communication error	Continue
		Hold						Retains the receive area from a local station with a communication error		

- \*1 If parameter setting has been made using the dedicated instructions, the data is held. If parameter setting has been made using GX Works2, the data is clear when the RY refresh device is set to Y, the data is cleared or held when the RY refresh device is set to other than Y. (Refer to  Page 134, Section 8.2.5.)
- \*2 When Y is set to the refresh device of the remote output (RY) in the local station that has stopped, only the receive area from the stopped local station is cleared. The data is held or cleared according to the parameter settings when the device other than Y is set. (Refer to  Page 134, Section 8.2.5.)  
Operation continues for the receive areas from other stations.

## 8.2.7 Standby master function

This function enables the data link to continue working by switching the control to the standby master station (meaning a backup station for the master station) if a system down occurs in the master station due to a malfunction in the programmable controller CPU or power supply.

The master station can return to normal and to system operation as the standby master station, even during data-link control by the standby master station, thus preparing itself for a standby master station system down (master station duplex function).

### (1) Types of the standby master function

The standby master function can be categorized into three types as listed below.

Function	When the master station goes down, the standby master station operates as a master station to continue data link.	When a failed master station becomes normal again, it return as a standby master station.	When only a standby master station is started up, it starts data link as a master station.
Master station switching function	○	×	× <sup>*1</sup>
Master station duplex function	○	○	× <sup>*1</sup>
Data link start function using a standby master station <sup>*2</sup>	○	○	○

○: Enabled, ×: Disabled

\*1 A standby master station does not start data link until the master station starts up.

\*2 Configure the same system for the master station and standby master station (same modules connected, parameters, and program).

## (2) Operation of the standby master function

The following are the operations of the master station and standby master station of when the master station goes down.

The following figures show the operation until a failed master station goes back to normal after the standby master station starts to operate as a master station and data link is continued.

Controlling: Controlling the data link of the CC-Link system

Standby status: Standing by in case the station controlling the data link of the CC-Link system becomes faulty.

Data link control by the master station

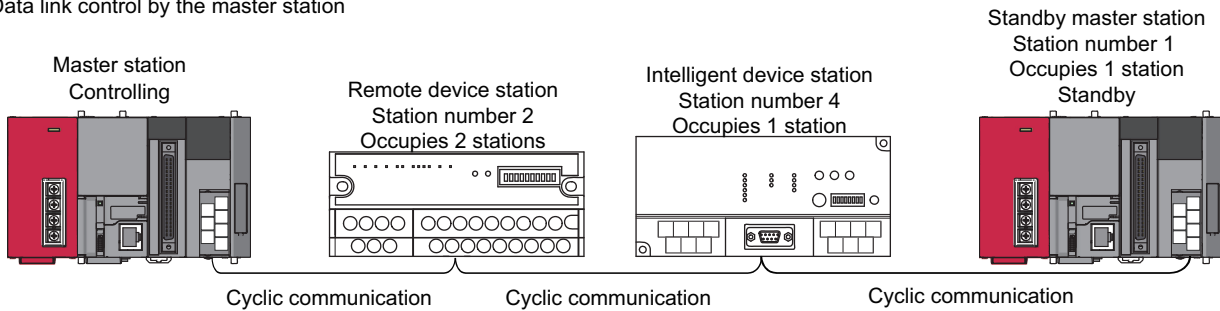

Master station is down → Data link control by the standby master station

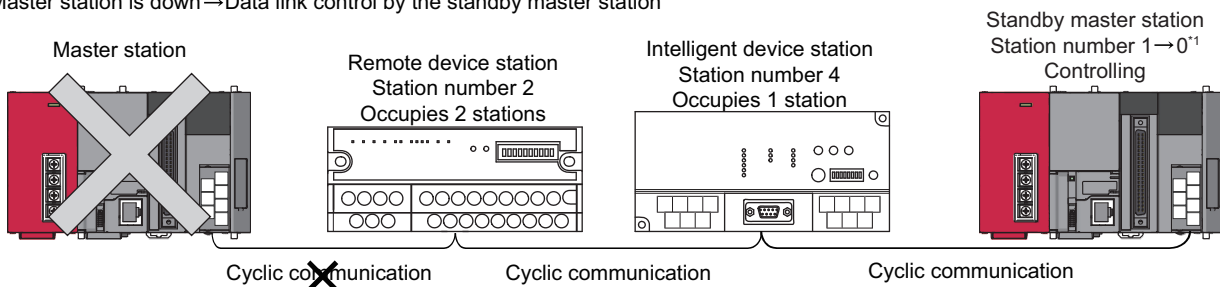

The master station in the normal state returns to the system operation. → The master station is on standby in case of the standby master station failure.

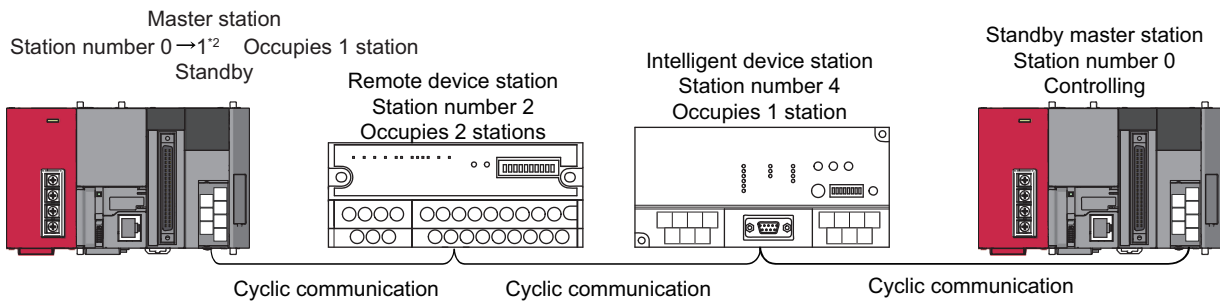

To the next figure

- \*1 When the master station goes down and the standby master station starts to take in control of data link, the station number of the standby master station becomes 0.
- \*2 When the master station returns as a standby master station, the station number of the master station becomes the number set in "Standby Master Station No." of the network parameter.

Continued from the previous figure



An error has occurred in the standby master station. → Data link is controlled by the master station.

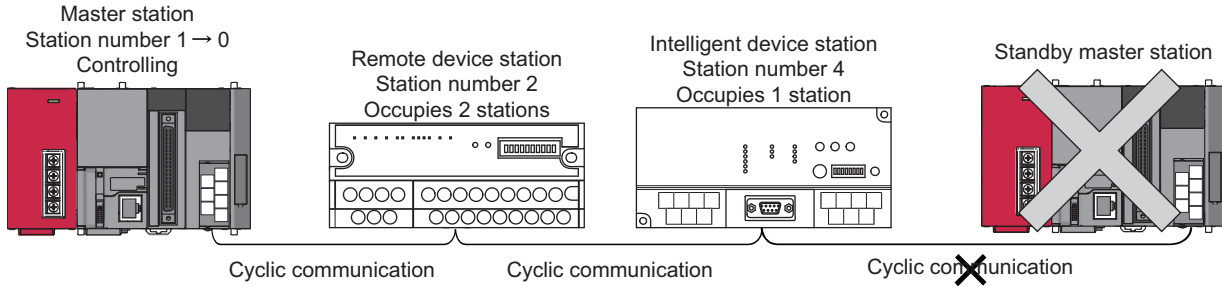

The standby master station in the normal state returns to the system operation. → The standby master station is on standby in case of the master station failure.

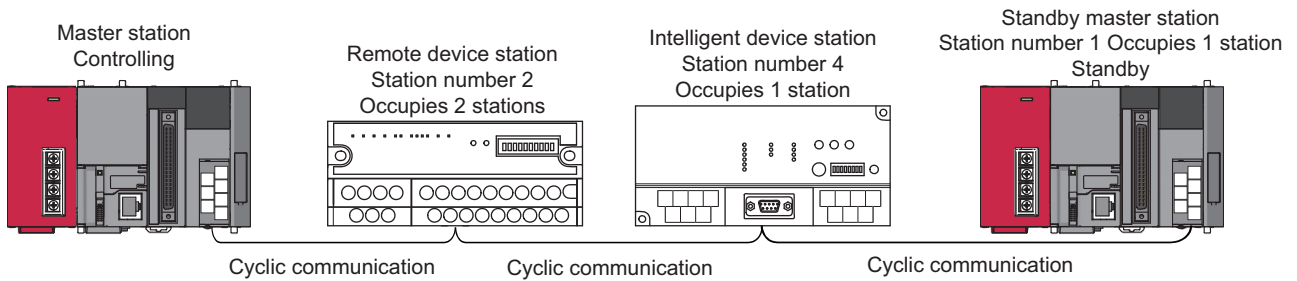

### (3) Overview of link data transmission when the standby master function is used

The following shows an overview of link data transmission when the standby master function is used.

#### (a) When the master station controls the data link

- Master station output

Outputs (RY/RWw) from the master station are stored in inputs (RX/RWr) of the standby master station (shaded areas in the figure below).

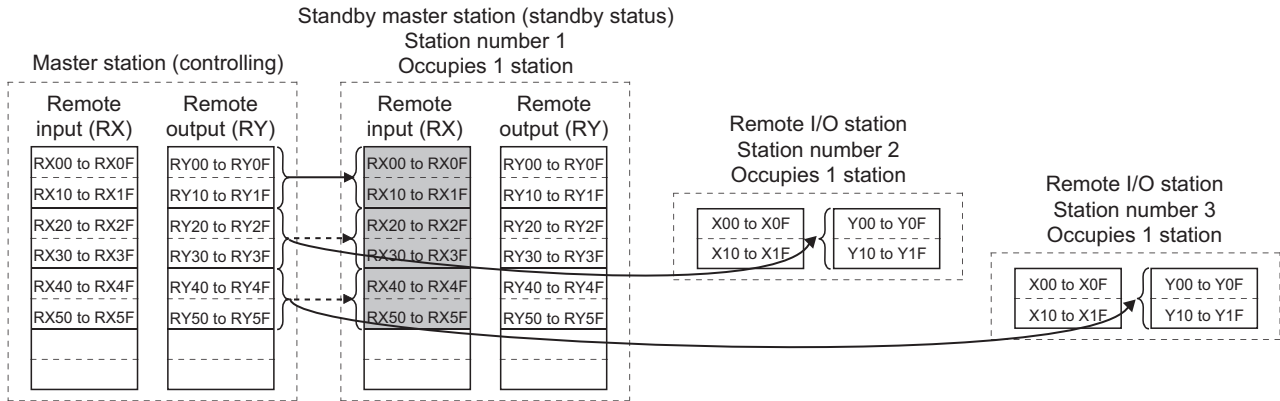

- Master station input

Inputs (RX/RWr) from slave stations to the master station are stored in outputs (RY/RWw) of the standby master station (shaded areas in the figure below).

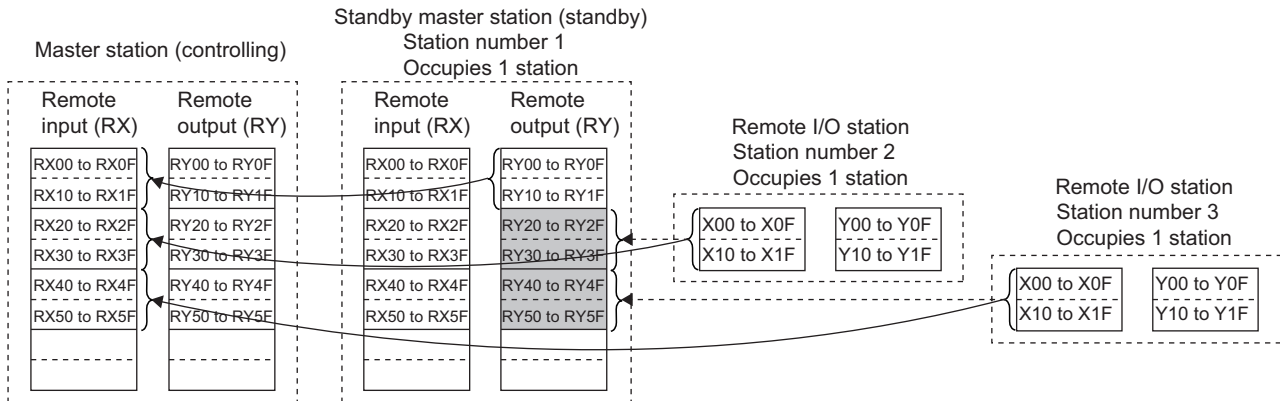

**(b) Master station down → Standby master station data link control**

If the master station goes down, the standby master station takes over the control of data link as the master station.

- Standby master station output

Outputs (RY/RWw) of the master station are stored in inputs (RX/RWr) of the standby master station. By transferring the inputs (RX/RWr) of the standby master station to the outputs (RY/RWw), outputs to the slave stations are continued (shaded areas in the figure above). (Refer to  Page 152, Section 8.2.7 (8).)

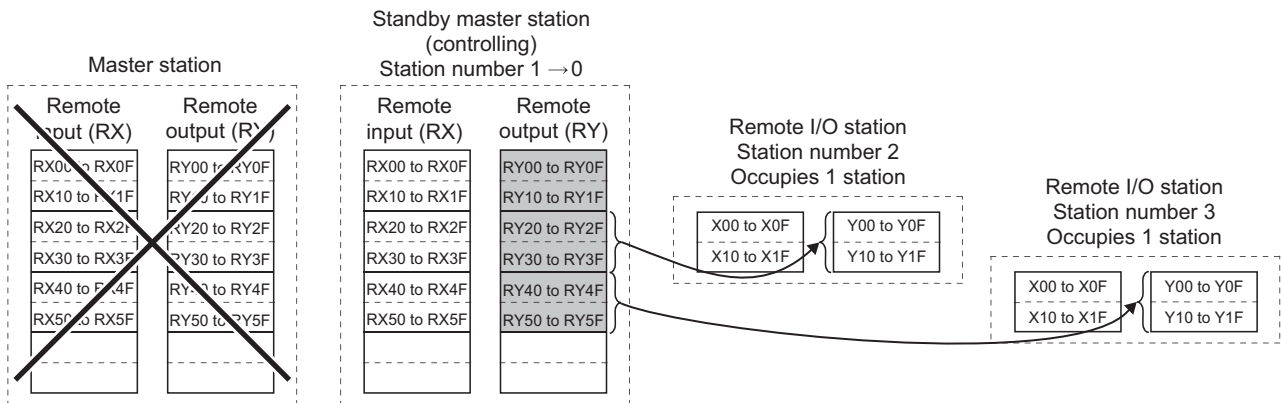

- Standby master station input

Inputs (RX/RWr) of the master station are stored in outputs (RY/RWw) of the standby master station. By transferring the outputs (RY/RWw) of the standby master station to the inputs (RX/RWr), inputs from the slave stations are continued (shaded areas in the figure above). (Refer to  Page 152, Section 8.2.7 (8).)

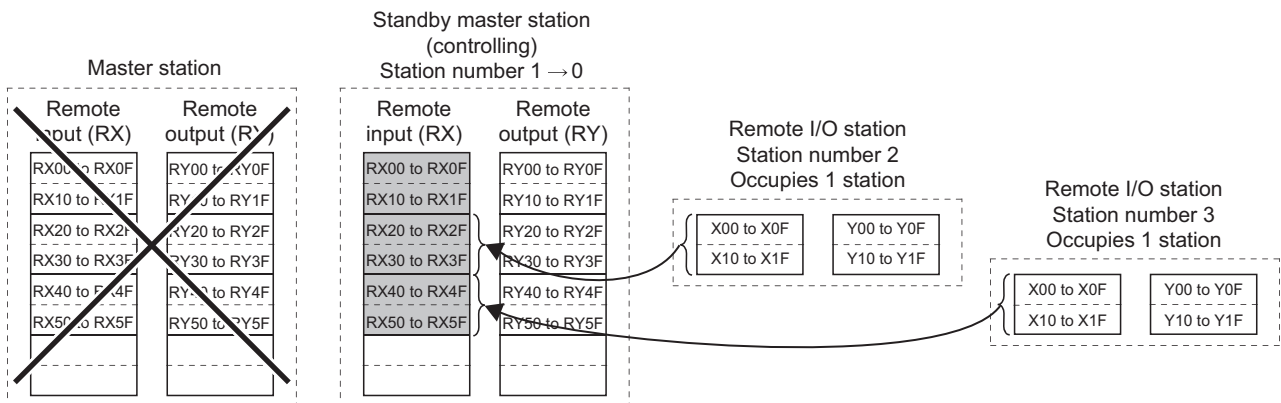

**(c) When the master station returns to system operation and the standby master station is controlling the data link**

- Standby master station output

Outputs (RY/RWw) from the standby master station are stored in inputs (RX/RWw) of the master station (shaded areas in the figure below).

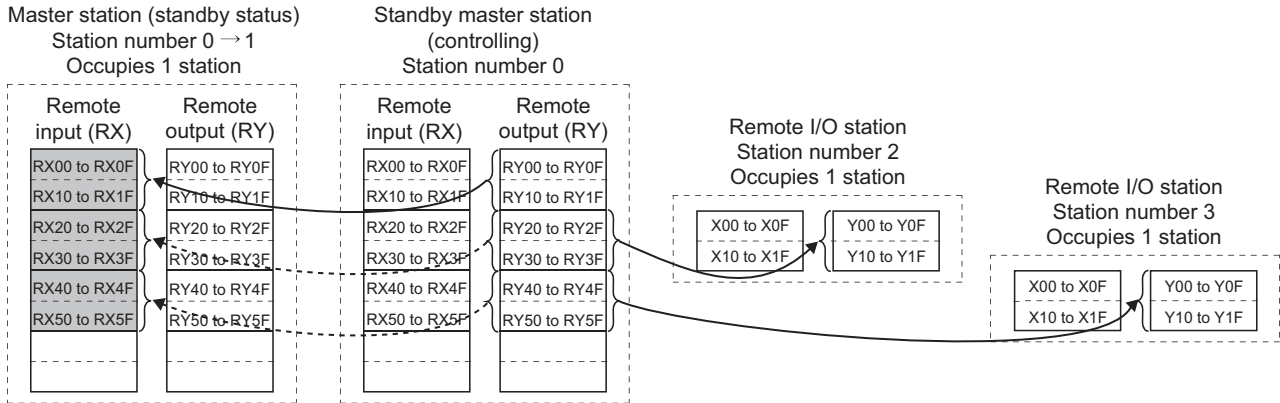

- Standby master station input

Inputs (RX/RWw) from slave stations to the standby master station are stored in outputs (RY/RWw) of the master station (shaded areas in the figure below).

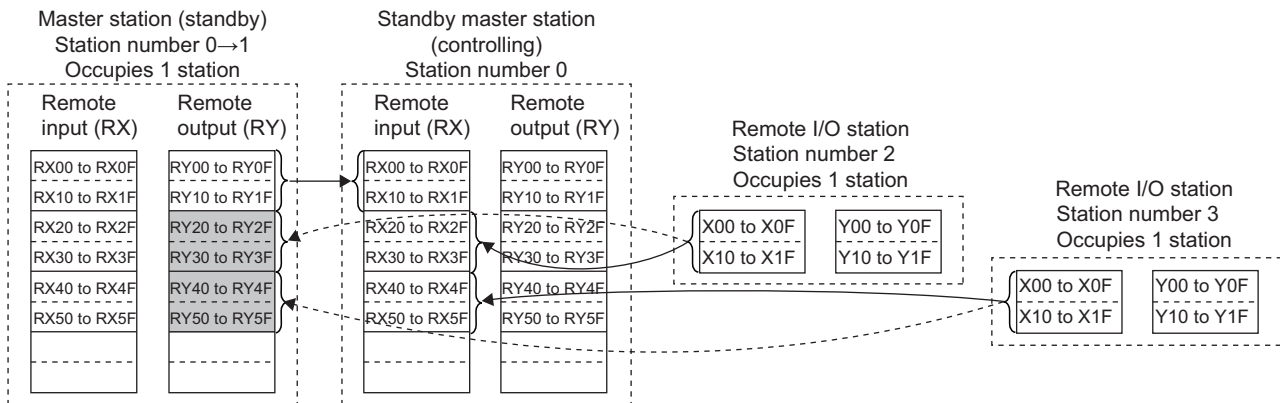

**(d) Standby master station down → Master station data link control**

If the standby master station goes down, the master station takes over the control of data link.

- Master station output

Outputs (RY/RWw) of the standby master station are stored in inputs (RX/RWw) of the master station. By transferring the inputs (RX/RWw) of the master station to the outputs (RY/RWw), outputs to the slave stations are continued (shaded areas in the figure above). (Refer to  Page 152, Section 8.2.7 (8).)

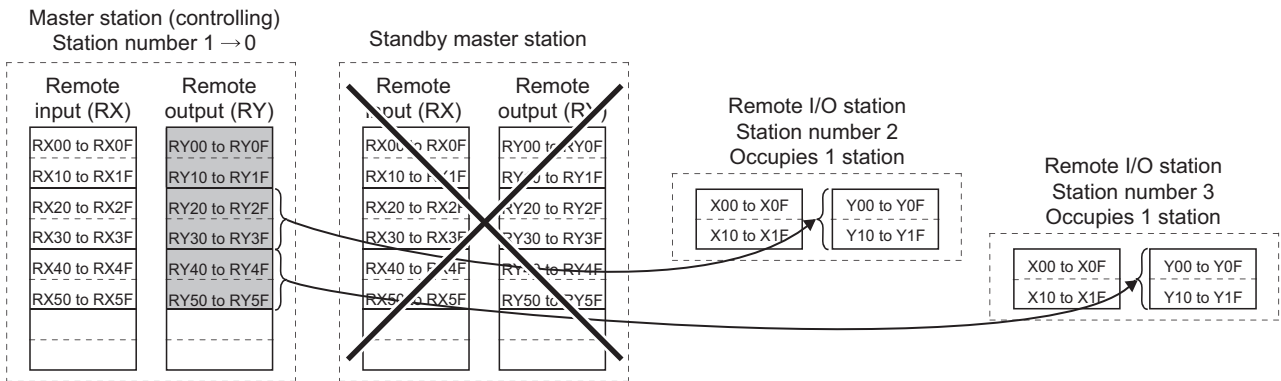

- Master station input

Inputs (RX/RWw) of the standby master station are stored in the outputs (RY/RWw) of the master station. By transferring the outputs (RY/RWw) of the master station to the inputs (RX/RWw), inputs from the slave stations are continued (shaded areas in the figure above). (Refer to  Page 152, Section 8.2.7 (8).)

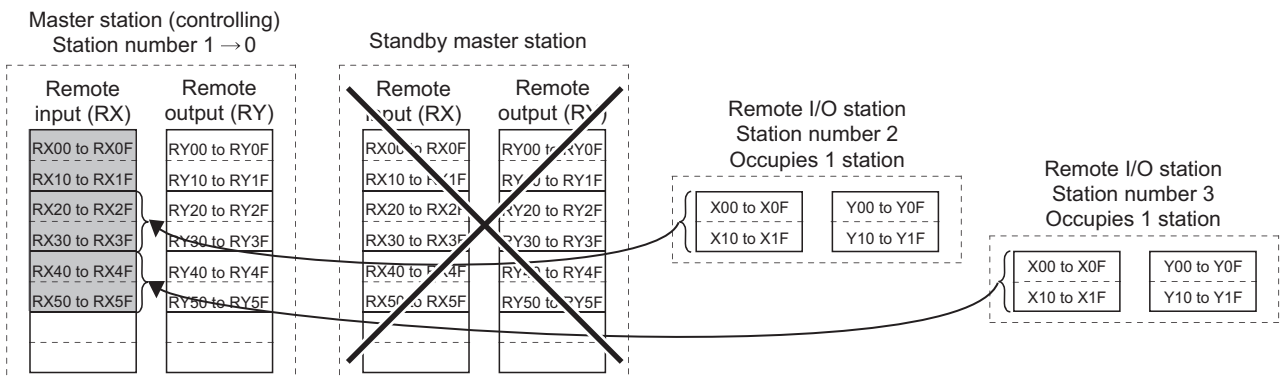



### (4) Setting method

Perform the setting using GX Works2.

#### (a) Setting the master station

Configure the settings in "Type" and "Standby Master Station No." of the network parameter as follows.

For other settings, refer to  Page 77, Section 7.3.2

1. Open the "Network Parameter" window to configure the setting in "Type" as follows.

Function	Operation			Setting in "Type"
	When the master station goes down, the standby master station operates as a master station to continue data link.	When a failed master station becomes normal again, it returns as a standby master station.	When only a standby master station is started up, it starts data link as a master station.	
Master station switching function	○	×	×	Master Station
Master station duplex function	○	○	×	Master Station (Duplex Function)
Data link start function using a standby master station	○	○	○	Master Station (Duplex Function)

○: Enabled, ×: Disabled

2. Set the station number to 0 when "Master Station (Duplex Function)" is selected in "Type".
3. Set "Standby Master Station No." from 1 to 64.

 When "Master Station (Duplex Function)" is selected in "Type"

Start I/O No.	1
Operation Setting	Operation Setting
Type	Master Station(Duplex Function)
Station No.	0
Master Station Data Link Type	PLC Parameter Auto Start
Mode	Remote Net(Ver.1 Mode)
Transmission Speed	10Mbps
Total Module Connected	3
Remote input(RX)	X1000
Remote output(RY)	Y1000
Remote register(RWr)	W0
Remote register(RWv)	W100
Ver.2 Remote input(RX)	
Ver.2 Remote output(RY)	
Ver.2 Remote register(RWr)	
Ver.2 Remote register(RWv)	
Special relay(SB)	SB0
Special register(SW)	SW0
Retry Count	3
Automatic Reconnection Station Count	1
Standby Master Station No.	1
PLC Down Select	Stop
Scan Mode Setting	Asynchronous
Delay Time Setting	0
Station Information Setting	Station Information
Remote Device Station Initial Setting	Initial Setting
Interrupt Settings	Interrupt Settings

**(b) Setting the standby master station**

Configure the settings in "Type" and "Mode" of the network parameter as follows.

For other settings, refer to  Page 99, Section 7.4.2

**1. Open the "Network Parameter" window to configure the setting in "Type" as follows**

Function	Operation			Setting in "Type"
	When the master station goes down, the standby master station operates as a master station to continue data link.	When a failed master station becomes normal again, it returns as a standby master station.	When only a standby master station is started up, it starts data link as a master station.	
Master station switching function	○	×	×	Standby Master Station
Master station duplex function	○	○	×	Standby Master Station
Data link start function using a standby master station	○	○	○	Master Station (Duplex Function)

○: Enabled, ×: Disabled

**2. Set the station number from 1 to 64.**

Set the same number as that of "Standby Master Station No." that was set for the master station.

**3. Set the same mode as that of the master station in "Mode".**

**4. When "Master Station (Duplex Function)" has been selected in "Type", set the same settings as those of the master station in items other than "Type" and "Mode".**

 When "Standby Master Station" is selected in "Type"

Start I/O No.	1
Operation Setting	Operation Setting
Type	Standby Master Station
Station No.	1
Master Station Data Link Type	
Mode	Remote Net(Ver. 1 Mode)
Transmission Speed	Auto-tracking
Total Module Connected	
Remote input(RX)	X1000
Remote output(RY)	Y1000
Remote register(RWr)	W0
Remote register(RWw)	W100
Ver. 2 Remote input(RX)	
Ver. 2 Remote output(RY)	
Ver. 2 Remote register(RWr)	
Ver. 2 Remote register(RWw)	
Special relay(SB)	SB0
Special register(SW)	SW0
Retry Count	
Automatic Reconnection Station Count	
Standby Master Station No.	
PLC Down Select	
Scan Mode Setting	
Delay Time Setting	
Station Information Setting	
Remote Device Station Initial Setting	
Interrupt Settings	Interrupt Settings

## (5) Precautions

### (a) The number of standby master stations

One standby master station can be connected in one system.

### (b) Right of controlling data link of a standby master station

When a master station goes down, the right of controlling data link is automatically transferred to a standby master station. Note that an instruction to refresh cyclic data is not issued. Use a link special relay (SB) and link special register (SW) to issue a refresh instruction. (☞ Page 150, Section 8.2.7 (6))

After the instruction is issued, information before a master station error is detected is output to each station.

### (c) Change in the parameter settings of the master station

While data link is performed by a standby master station, the parameter settings of the master station cannot be changed.

### (d) Station number setting for a standby master station

If the station number setting in "Station No." of the network parameter on a standby master station differs from that set in "Standby Master Station No." of the network parameter for the master station, an error (error code: B39A<sub>H</sub>) occurs in the standby master station.

If an error has occurred, reset the CPU module of the standby master station after changing "Standby Master Station No." of the master station or changing the station number set using "Station No." of the standby master station.

### (e) If the terminal block of a master station is removed while the master station is controlling data link

If the terminal block of a master station is removed without powering off the master station and reconnected, both of the master station and standby master station will perform master operation because the right of controlling data link is transferred to the standby master station; therefore, communications cannot be normally performed. By powering off the master station and reconnecting the terminal block and powering on the master station, the master station is reconnected as standby master station operation; therefore, communications can be normally performed.

### (f) The status of an LED when the right of controlling data link is transferred to a standby master station

When the master station goes down and the standby master station starts to take in control of data link, the ERR. LED on the standby master station flashes. The station number of the standby master station is changed from the one set in the parameters to the station number 0, and the standby master station is regarded that it is not connected. Data link is normally performed.

To prevent this situation, set the standby master station as an error invalid station.

### (g) Number of points and range of devices to back up data using a program

The number of points and range of devices where data from a master station (station operating as a master station) to a standby master station (station operating as a standby master station) are backed up using a program vary depending on the system.

### (h) If an error is detected in the master station in the initial status (before data link is started)

The operation is not switched from the standby master station to the master station, and data link is not started. (This applies only to the master station switching function and master station duplex function.)

**(i) Processing that sets the link devices saved at master switching and refresh instruction at standby master switching**

After saving the link devices, wait a fixed number of scans and execute the processing that sets the link devices saved at master switching and Refresh instruction at standby master switching (SB0001).  
Number of scans for waiting after saving the link devices differs depending on the mode setting. Use the following values.

Mode setting	Number of scans for waiting	Remark
Remote net Ver.1 mode Remote I/O net mode	Fixed to 0	—
Remote net Ver.2 mode Remote net additional mode	(Link scan time / Sequence scan time) (Rounded up to the nearest integer) × 4	<ul style="list-style-type: none"> <li>• For link scan time, use the maximum value after master switching.</li> <li>• For sequence scan time, use the minimum value after master switching.</li> </ul>

**(6) Link special relays/registers (SB and SW) relating to the standby master function**

The following shows the list of the link special relays and registers relating to the standby master function.

For details, refer to  Page 409, Appendix 3.

Link special relay/register	Number	Name
Link special relay	SB0001	Refresh instruction at standby master switching
	SB000C	Forced master switching
	SB0042	Refresh instruction acknowledgement status at standby master switching
	SB0043	Refresh instruction complete status at standby master switching
	SB0046	Forced master switching executable status
	SB005A	Master switching request acknowledgement
	SB005B	Master switching request complete
	SB005C	Forced master switching request acknowledgement
	SB005D	Forced master switching request complete
	SB0062	Host standby master station setting information
	SB0070	Master station information
	SB0071	Standby master station information
	SB0079	Master station return specification information
	SB007B	Host master/standby master operation status
Link special register	SW0043	Refresh instruction at standby master switching result
	SW005D	Forced master switching instruction result
	SW0073	Standby master station number

## (7) On/off timings of link special relays (SB) relating to the standby master function

The following shows the on/off timings of the link special relays (SB) relating to the standby master function.

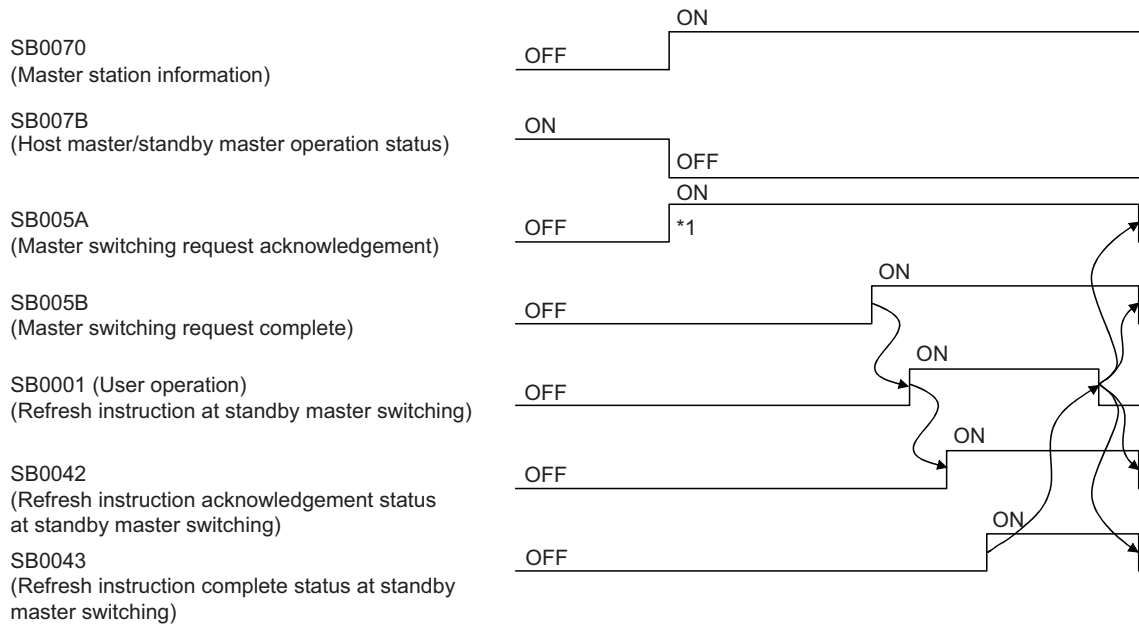

- \*1 When turning on SB005A, save data stored in RX, RY, RWr, and RWw to the devices and set data stored in RX to RY, data stored in RY to RX, data stored in RWr to RWw, and data stored in RWw to RWr using a program. In addition, turn on SB0001.
- After saving data stored in RX, RY, RWr, and RWw to the devices, wait a fixed number of scans and execute the processing that sets data stored in RX to RY, data stored in RY to RX, data stored in RWr to RWw, and data stored in RWw to RWr using a program and the processing that turns on SB0001.
- For details, refer to Page 149, Section 8.2.7 (5)

## (8) Program example when the standby master function (master station duplex function) is used

A program example is created under the following conditions when the standby master function (master station duplex function) is used.

### (a) System configuration

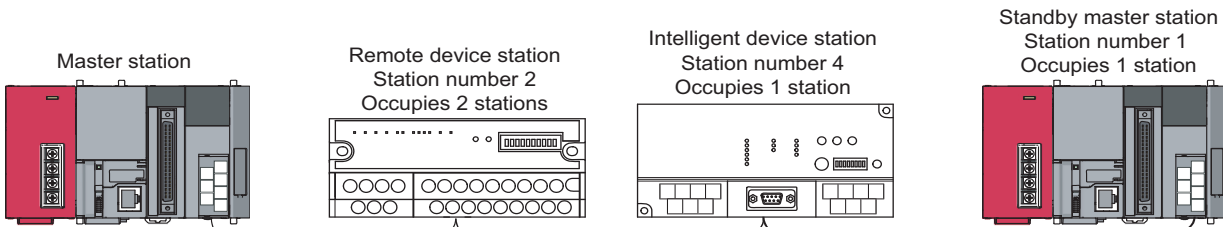

### (b) Parameter settings of the master station

Start I/O No.	1	0000
Operation Setting	Operation Setting	
Type	Master Station(Duplex Function)	
Station No. (*1)	0	
Master Station Data Link Type	PLC Parameter Auto Start	
Mode	Remote Net(Ver. 1 Mode)	
Transmission Speed(*1)	10Mbps	
Total Module Connected(*1)	3	
Remote input(RX)	X1000	
Remote output(RY)	Y1000	
Remote register(RWr)	W0	
Remote register(RWw)	W100	
Ver. 2 Remote input(RX)		
Ver. 2 Remote output(RY)		
Ver. 2 Remote register(RWr)		
Ver. 2 Remote register(RWw)		
Special relay(SB)	SB0	
Special register(SW)	SW0	
Retry Count	3	
Automatic Reconnection Station Count	1	
Standby Master Station No. (*1)	1	
PLC Down Select	Stop	
Scan Mode Setting	Asynchronous	
Delay Time Setting	0	
Station Information Setting	CC-Link Configuration Setting	
Remote Device Station Initial Setting	Initial Setting	
Interrupt Settings	Interrupt Settings	

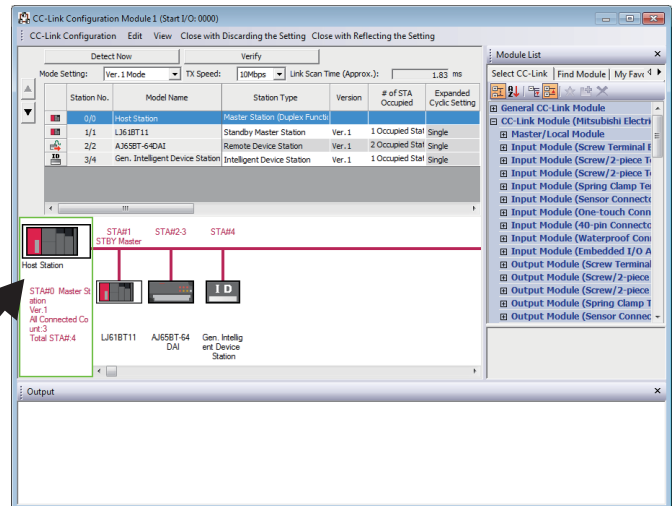

### (c) Parameter settings of the standby master station

Start I/O No.	1	0000
Operation Setting	Operation Setting	
Type	Standby Master Station	
Station No.	1	
Master Station Data Link Type		
Mode	Remote Net(Ver. 1 Mode)	
Transmission Speed	Auto-tracking	
Total Module Connected		
Remote input(RX)	X1000	
Remote output(RY)	Y1000	
Remote register(RWr)	W0	
Remote register(RWw)	W100	
Ver. 2 Remote input(RX)		
Ver. 2 Remote output(RY)		
Ver. 2 Remote register(RWr)		
Ver. 2 Remote register(RWw)		
Special relay(SB)	SB0	
Special register(SW)	SW0	
Retry Count		
Automatic Reconnection Station Count		
Standby Master Station No.		
PLC Down Select		
Scan Mode Setting		
Delay Time Setting		
Station Information Setting		
Remote Device Station Initial Setting	Initial Setting	
Interrupt Settings	Interrupt Settings	

**(d) Program example when standby master function (master station duplex function) is used**

- Control start relay used when master station is operating: M10
- Control start relay used when standby master station is operating: M11

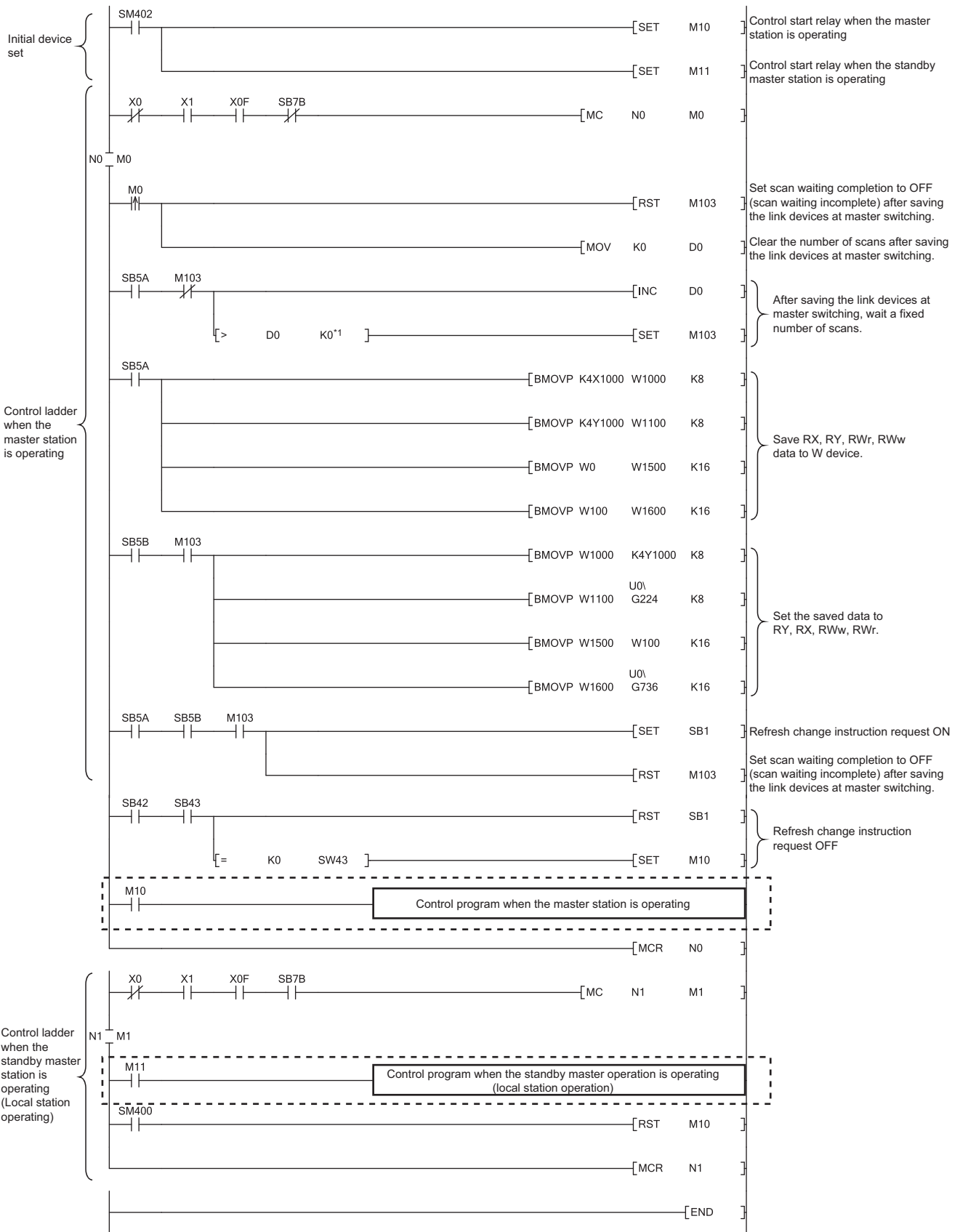

\*1 After saving the link devices, wait a fixed number of scans and execute the processing that sets the link devices saved at master switching and Refresh instruction at standby master switching (SB0001).

For details, refer to Page 149, Section 8.2.7 (5)



**(e) When forcibly switching the data link control right from the standby master station to the master station**

The areas enclosed by the broken and dotted lines in the program example shown in (d) must be modified as shown below.

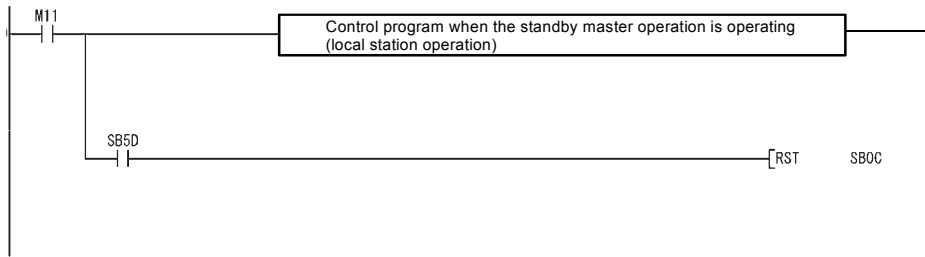
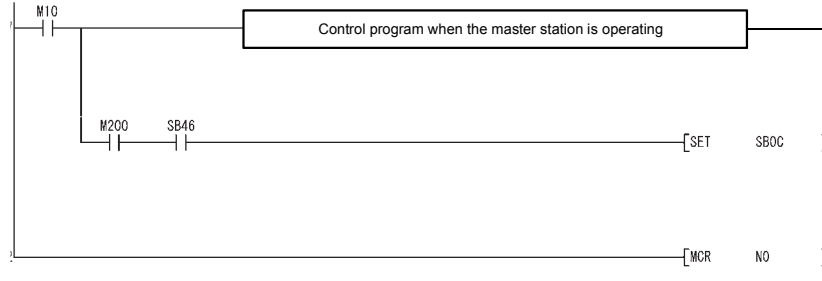

## 8.2.8 Data link start by standby master station

This function allows data link to start by turning on either of the master or standby master station.

When the standby master station is turned on, even if no power is applied to the master station, data link will start.

To enable this function, the same parameters and programs must be set to the master and standby master stations.

When using the standby station as a backup for the master station, utilize the standby master function explained in

 Section 4.3.6.

Controlling: Controlling the data link of the CC-Link system

Standby status: Standing by, waiting for a failure of the station controlling the data link of the CC-Link system

When only standby master station is started, data link is controlled by the standby master station.

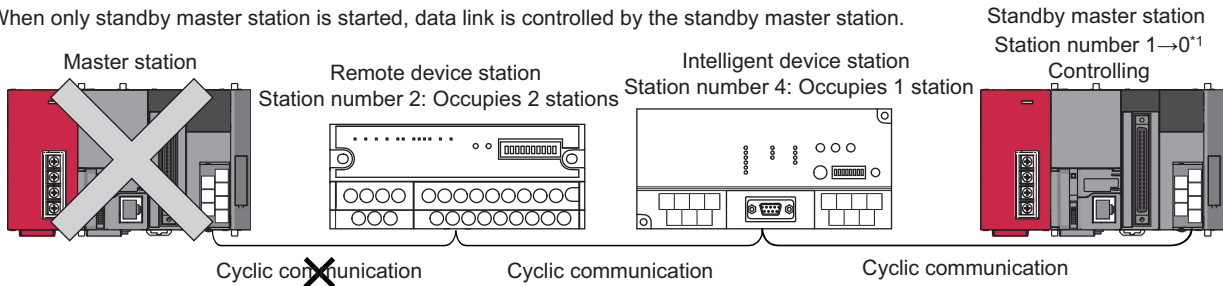

The master station in the normal state returns to the system operation. → The master station is on standby in case of the standby master station failure.

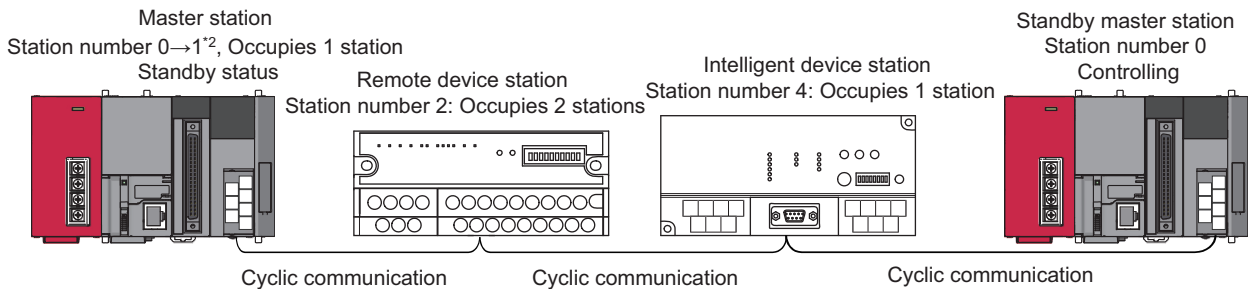

To the next figure

\*1 When the master station goes down and the data link control is switched to the standby master station, the station number of the standby master station becomes "0".

\*2 When the master station returns as a standby master station, the station number of the master station becomes the one specified in the "Standby Master Station No." in the network parameter setting.

Continued from the previous figure

Error occurred in standby master station → Master station controls data link.

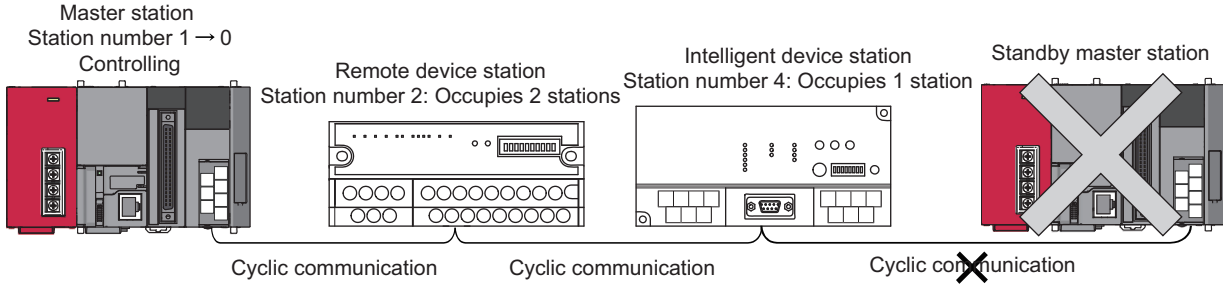

Standby master station returns to normal and comes back online → It stands by waiting for a master station failure

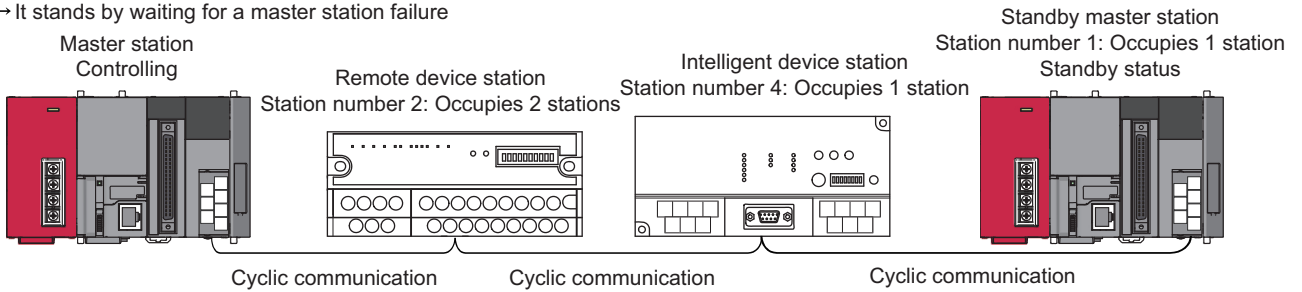

## (1) Setting method

The following shows how to make settings.

- (a) Set station No.0 for the master station, and any of station 1 to 64 for the standby master station.
- (b) Configure the same system (the same programmable controller CPU, I/O modules, and/or intelligent function modules) for the master and standby master stations.
- (c) Select "Master Station (Duplex Function)" for "Type" in the network parameter setting of GX Works2.
- (d) Set other network parameter items.

	1
Start I/O No.	
Operation Setting	Operation Setting
Type	Master Station(Duplex Function)
Station No.	0
Master Station Data Link Type	PLC Parameter Auto Start
Mode	Remote Net(Ver. 1 Mode)
Transmission Speed	10Mbps
Total Module Connected	3
Remote input(RX)	X1000
Remote output(RY)	Y1000
Remote register(RWr)	W0
Remote register(RWw)	W100
Ver. 2 Remote input(RX)	
Ver. 2 Remote output(RY)	
Ver. 2 Remote register(RWr)	
Ver. 2 Remote register(RWw)	
Special relay(SB)	SB0
Special register(SW)	SW0
Retry Count	3
Automatic Reconnection Station Count	1
Standby Master Station No.	1
PLC Down Select	Stop
Scan Mode Setting	Asynchronous
Delay Time Setting	0
Station Information Setting	Station Information
Remote Device Station Initial Setting	Initial Setting
Interrupt Settings	Interrupt Settings

- (e) Write the same parameters and programs to the master and standby master stations.

## (2) Precautions when starting data link by the standby master station

### (a) Parameters and program set in the master station and standby master station

Set the same parameters and program in the master station and standby master station. If not, the operation is not guaranteed.

### (b) Line test

When the data link start function by a standby master station is used, a line test cannot be executed using the mode setting. Use a programming tool to execute a line test. (  Page 378, Section 15.4.2 (1))

## 8.2.9 Block guarantee of cyclic data per station

This function allows guaranteeing the consistency of the cyclic data for each slave station according to the parameter setting.

To ensure the consistency of data exceeding two words, use this function.

When this function is not used, cyclic data may be separated into new data and old data in 2-word (32-bit) units, depending on the auto refresh timing.

Set this function to master stations, local stations and standby master stations.

The following example shows the range in which data of remote register RWw is secured when this function is set in the remote net Ver.1 mode.

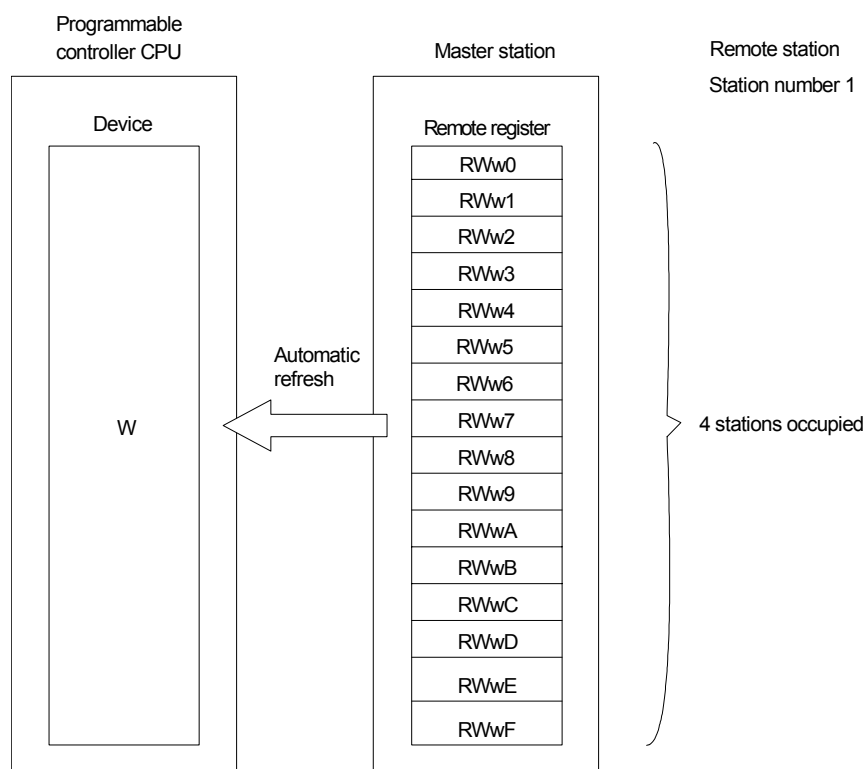

For slave station number 1 that has setting of "4 stations occupied" in the remote net Ver.1 mode, remote register data in the range RWw0 to RWwF are guaranteed.

Data are guaranteed in the same way for other remote devices (RX/Ry/RWr).

They are also guaranteed for remote devices (RX/Ry/RWr/RWw) in the remote I/O network mode.

The following example shows the range in which data of remote register RWw are guaranteed when this function is set in the remote net Ver.2 mode.

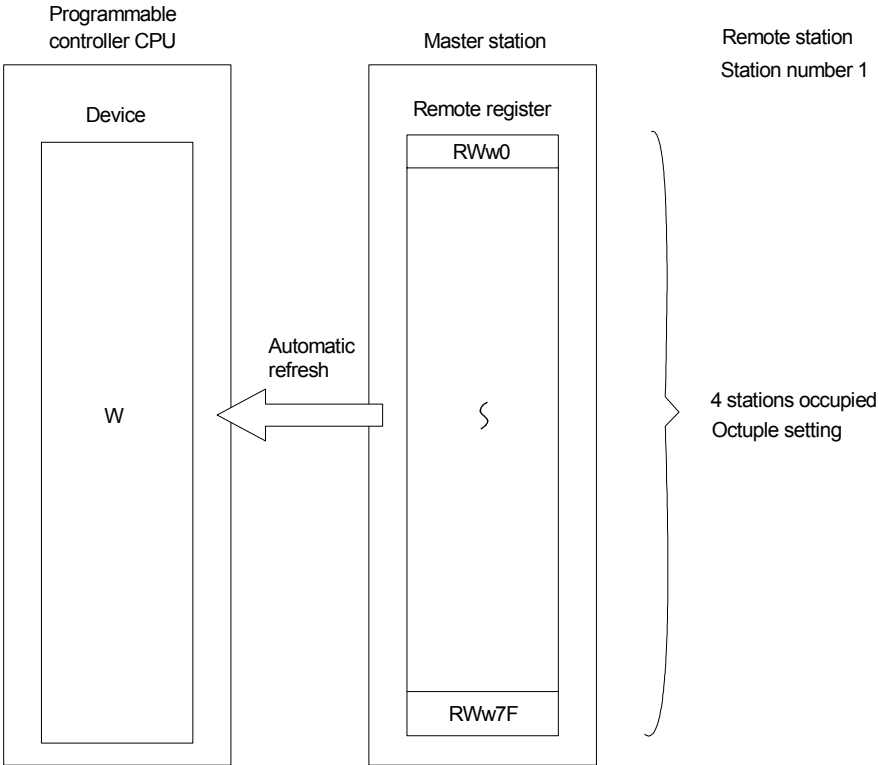

For slave station number 1 that has setting of "4 stations occupied" and "octuple" in the remote net Ver.2 mode, remote register data in the range RWw0 to RWw7F are guaranteed.

Data are guaranteed in the same way for other remote devices (RX/Ry/RWr).

They are also guaranteed for remote devices (RX/Ry/RWr/RWw) in the remote net additional mode.

## (1) Setting method

The following describes the setting method.

- (a) Click the **Operation Setting** button in the network parameter setting in GX Works2.

Start I/O No.	1
Operation Setting	Operation Setting
Type	Master Station
Station No.	0
Master Station Data Link Type	PLC Parameter Auto Start
Mode	Remote Net(Ver.1 Mode)
Transmission Speed	10Mbps
Total Module Connected	64
Remote input(RX)	
Remote output(RY)	
Remote register(RWr)	
Remote register(RWw)	
Ver.2 Remote input(RX)	
Ver.2 Remote output(RY)	
Ver.2 Remote register(RWr)	
Ver.2 Remote register(RWw)	
Special relay(SB)	
Special register(SW)	
Retry Count	3
Automatic Reconnection Station Count	1
Standby Master Station No.	
PLC Down Select	Stop
Scan Mode Setting	Asynchronous
Delay Time Setting	0
Station Information Setting	Station Information
Remote Device Station Initial Setting	Initial Setting
Interrupt Settings	Interrupt Settings

- (b) The [Operation Setting] window is displayed. Check the [Block Data Assurance per Station] checkbox.

The screenshot shows the 'Operation Setting Module 1' dialog box with the following settings:

- Parameter Name: (Empty text box)
- Number of Occupied Stations: Occupied Station 1
- Data Link Faulty Station Setting:  Hold Input Data
- Expanded Cyclic Setting: Single
- Case of CPU STOP Setting:  Clears Compulsorily
- Block Data Assurance per Station:  Enable Setting
- Machine Automatically Detection Setting:  Read the model name of slave node

- (c) Make the auto refresh settings for each remote device.

## (2) Precautions when using the block guarantee of cyclic data per station

### (a) When using this function, be sure to make the auto refresh settings.

If the auto refresh settings have not been made for all devices, remote input (RX), remote output (RY) and remote registers (RWr/RWw) in the buffer memory may not be refreshed.

The following message is displayed if the auto refresh settings have not been completed.

If this message is displayed, check the settings.

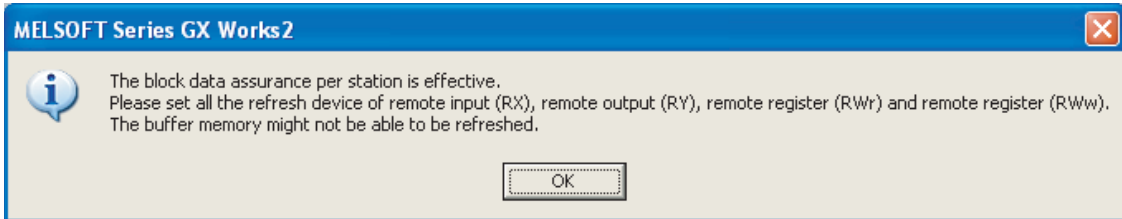



**(b) When this function is used, the transmission delay time increases (compared with when this function is not used).**

When designing a new system by using an existing system as it is, confirm the delay time of the data from the remote station before starting the system.

**Point** 

---

For the formula for calculating the transmission delay time when the block guarantee of cyclic data per station is used and when it is not used, refer to  Page 435, Appendix 4.2 to Page 443, Appendix 4.6.

---

**(c) When this function is used, the link refresh time increases (compared with when this function is not used).**

When designing a new system by using an existing system as it is, confirm the link refresh time before starting the system.

**Point** 

---

For the formula for calculating the link refresh time when the block guarantee of cyclic data per station is used and when it is not used, refer to  Page 454, Appendix 4.11.

---

## 8.2.10 Secured 32-bit data

When the following conditions, 1) and 2) are satisfied in the CC-Link network, 32-bit data in remote registers (RWr/RWw) between a programmable controller CPU and a master/local station can be secured.

1) Access starts from a remote register (RWr/RWw) address of an "even number".

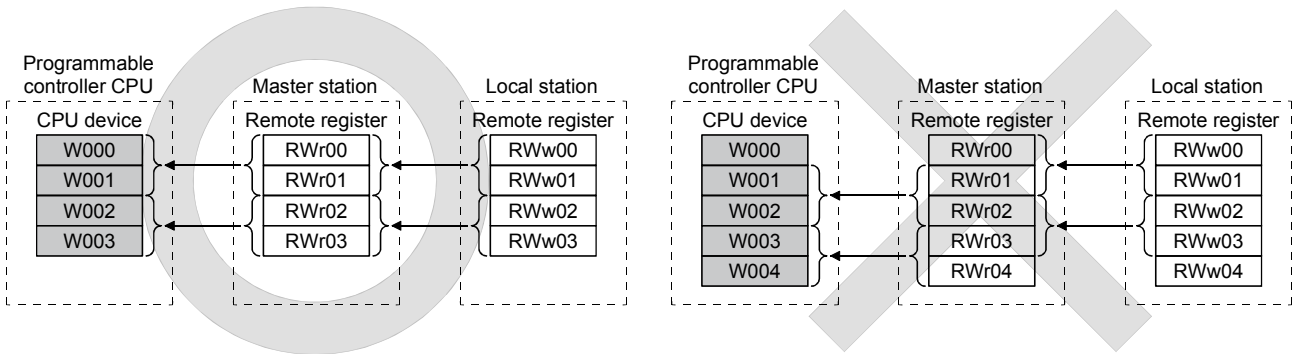

\*Because the start address on the remote register side is an "odd address", new and old data may be mixed in 16-bit (1-word) units.

2) Access by the program must be made in units of even points.

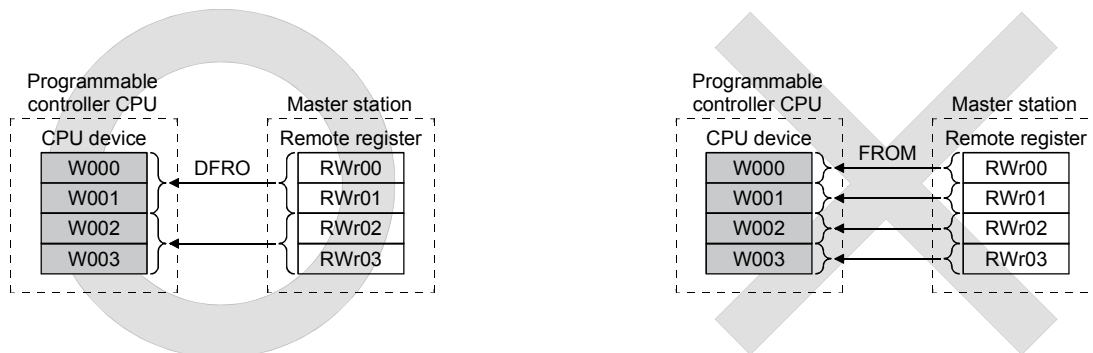

\*Because the access is made for each single point (1-word), new and old data may be mixed in 16-bit (1-word) units.

## 8.3 Handy Functions

This section explains some handy functions of the L series master/local module.

### 8.3.1 Remote device station initialization procedure registration function

The initial settings of remote device stations can be performed using GX Works2 for registration to the programmable controller CPU.

The L series master/local module instructs registration or remote device station initialization procedure (SB000D) and then stores the number of the currently executing procedure to the buffer memory. For this reason, when processing has stopped, the relevant information such as the procedure number or target station number can be confirmed. For details on procedure numbers, refer to  (1)(b)(9) in Section 8.3.1.

Also, if a running remote device station is replaced due to a failure, initial processing that has been done for all stations before can be performed for the replaced remote device station by specifying it. Remote device stations other than the specified station continue to operate.

For example, in an AJ65BT-64AD, settings such as "A/D conversion enable/prohibit specification" and "Averaging process specification" can be easily configured.

For the availability of this function, refer to the manuals of the remote device stations to be used.

#### (1) Number of setting items for remote device station initialization procedure registration

Remote device station initialization procedure registration can be executed up to 16 items per remote device station.

If setting 17 items or more is necessary, execute initial setting with the program.

The initial processing in the remote device station initialization procedure registration and initial settings with the program cannot be executed at the same time.

Executing them at the same time may cause remote device station malfunction.

Remote device station initialization procedure registration can be executed up to 16 stations.

When 17 or more remote device stations are connected, execute the initial settings for the 17th and subsequent stations using the program.

#### (2) Remote device station initialization procedure setting method

Configure the settings in "Remote Device Station Initial Setting" in the network parameter setting of the master station, and reflect the initial settings to the remote device station by using the remote device station initialization procedure registration instruction (SB000D).

For setting examples using GX Works2, refer to  Page 253, Section 11.1.2 (4), Page 265, Section 11.2.2 (4), and Page 278, Section 11.3.2 (4).

- (a) In "Target Station No.", set the station number of the module for which the initial settings are to be performed.

Setting range: 1 to 64

	Target Station No.	No. of Registered Procedures		Target Station No.	No. of Registered Procedures		
1	3	2	Regist Procedure	9			Regist Procedure
2	5	1	Regist Procedure	10			Regist Procedure
3			Regist Procedure	11			Regist Procedure
4			Regist Procedure	12			Regist Procedure
5			Regist Procedure	13			Regist Procedure
6			Regist Procedure	14			Regist Procedure
7			Regist Procedure	15			Regist Procedure
8			Regist Procedure	16			Regist Procedure

Clear Check End Cancel

- (b) Set the initial setting procedure in "Regist Procedure".

**1. Input format**

Set the data input format for "Write Data" in details of execution.

Setting range:	DEC.
	HEX.
Default:	DEC.

**2. Execute Flag**

Set whether or not to execute the specified initial setting procedure.

Setting range:	Execute
	Only set (use as a memo when the execution conditions are the same as when the execution flag is set as "Execute", but the content of execution is different.)
Default:	Execute

**3. Operational condition**

Select whether to newly set the condition for the initial settings or use the previous condition.

Setting range:	Set New
	Same as Prev. Set
Default:	Set New

**4. Executional condition settings "Condition Device"**

Set the device to be used for the initial setting operating condition.

Setting range:	RX
	SB

**5. Executional condition settings "Device No."**

Set the device number to be used for the initial setting operating condition.  
Even if the target station number is different, the same number must be set.

Setting range:	When RX is selected 0 to 37F (H)
	When SB is selected 0 to FF (H)

**6. Executional condition settings "Execute Condition"**

Set the conditions under which initial settings are performed.

Setting range:	ON
	OFF

**7. Details of execution "Write Device"**

Set the device to which the contents of the initial setting are written.

Setting range:	RY
	RWw

**8. Details of execution "Device No."**

Set the device number to which the contents of the initial settings are written.  
Even if the target station number is different, the same number must be set.

Setting range:	When RY is selected: 0 to 37F (H)
	When RWw is selected: 0 to 0F (H)

**9. Details of execution "Write Data"**

Set the contents of the initial settings.

Setting range:	When RY is selected: ON/OFF
	When RWw is selected: 0 to 65535 (Decimal), 0 to FFFF (Hexadecimal)

The following shows the procedure registration window appeared after setting of (1) to (9).  
For procedure numbers, the first line of the window is regarded as procedure number 1.

### (3) Method for initializing only a specified station (specification of remote device station to be initialized)

When a running remote device station is replaced due to a failure, initial processing that has been done for all stations conventionally can be performed for the replaced remote device station by specifying it. Remote device stations other than the specified station continue their operations.

The following shows an example in which remote device station number 3 is specified to be initialized.

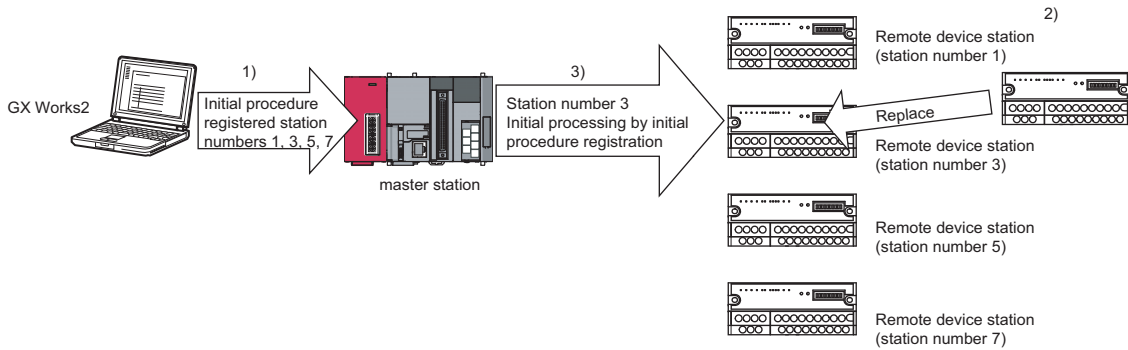

1. First of all, execute the initial settings for all remote device stations (station numbers 1, 3, 5, 7).
2. When a failure occurs on remote device station number 3 during operation, replace the failed remote device station.
3. Specify the replaced station number 3 as a remote device station to be initialized. Then, perform the initial processing.

During initial processing of station number 3, control of the other stations (station numbers 1, 5, 7) is continued.

#### (a) How to specify the remote device station to be initialized

Set the station to be initialized in the "specification of remote device station to be initialized (SW0014 to SW0017)" in the link special register.

To set this, turn ON the bit corresponding to the specified station number within SW0014 to SW0017 (only the bit of the head station number).

When all bits are OFF, initial processing is performed on all stations that are set in the "Remote Device Station Initial Setting" in the network parameter setting.

	b15	b14	b13	b12	b11	b10	b9	b8	b7	b6	b5	b4	b3	b2	b1	b0
SW0014	16	15	14	13	12	11	10	9	8	7	6	5	4	3	2	1
SW0015	32	31	30	29	28	27	26	25	24	23	22	21	20	19	18	17
SW0016	48	47	46	45	44	43	42	41	40	39	38	37	36	35	34	33
SW0017	64	63	62	61	60	59	58	57	56	55	54	53	52	51	50	49

Numbers 1 to 64 in the above table indicate the station numbers.

#### (4) Enable initial settings

Before creating a program for communication with remote device stations, create a program to enable the initial settings using SB000D (remote device station initialization procedure registration instruction) and SB005F (completion status of remote device station initialization procedure execution).

For details, refer to  Page 255, Section 11.1.3, Page 267, Section 11.2.3 and Page 280, Section 11.3.3.

Procedure for the remote device station initialization procedure registration

**1. Turn SB000D ON, and start to execute the registered initial setting.**

During execution of initial processing, SB005E (remote device station initialization procedure execution status) stays ON.

Also, the execution procedure numbers and target station numbers of the registration are stored to SW0110 to SW011F (remote device station initialization procedure registration execution individual information).

**2. When initial processing of all preset stations is completed, SB005F turns ON.**

Also, the execution result is stored to SW005F (remote device station initialization procedure instruction result).

The execution procedure numbers in SW0110 to SW011F become FF00<sub>H</sub>.

**3. When SB000D is turned OFF on completion of initial processing (SB005F : ON), SB005F, and SW0110 to SW011F are cleared.**

The following shows operation of the link special relays and link special registers when remote device station initialization procedure registration is performed.

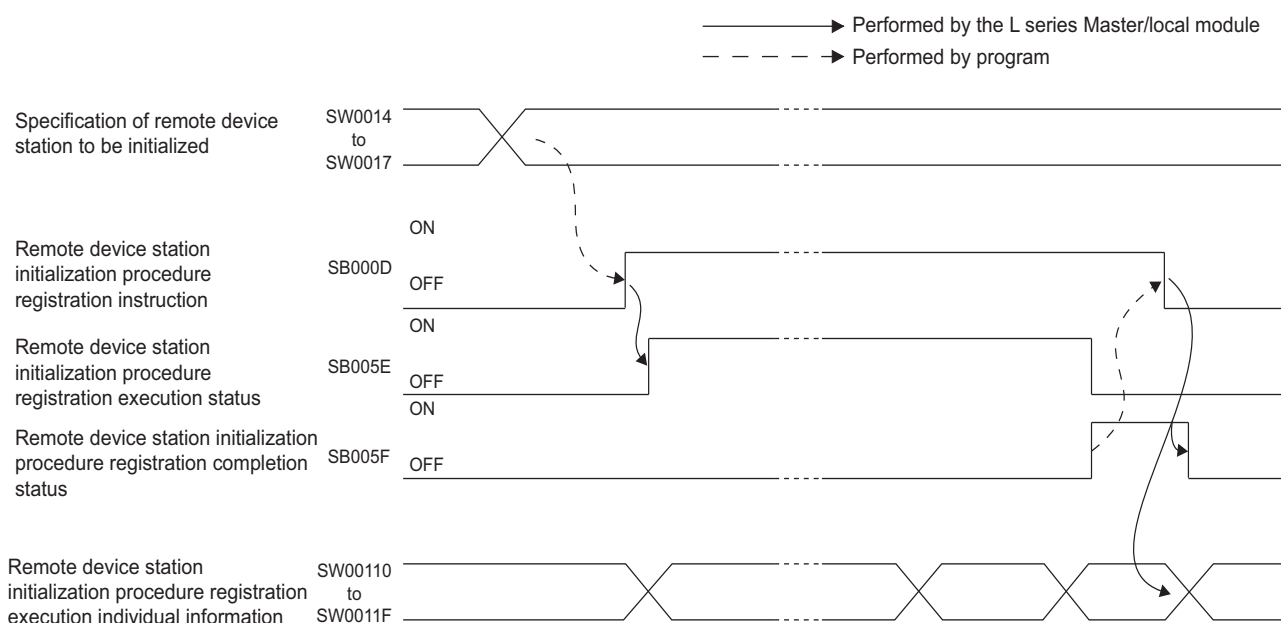

## (5) Preparation for communication with remote device stations

1. Register the network parameters and the created program in the programmable controller CPU.
2. Reset the programmable controller CPU or power it off and then on.
3. Instruct the master station to register the remote device station initialization procedure (SB000D).  
(This instruction may not be necessary in some cases such as when the remote input RX is set as a startup condition.)

### *Point*

---

- Because one step is performed per link scan, as the number of settings increases the processing time will extend beyond that specified in the program.
  - While the remote device station initialization procedure registration instruction (SB000D) is on, the refresh of the remote input/output and remote registers stops.
  - When the remote device station initialization procedure registration instruction (SB000D) turns OFF after completion of the initial processing, all of RY signals that have turned ON during the initial processing turn OFF. Therefore, for signals that should be kept ON (e.g. CH.□ Conversion enable flag of the AJ65BT-64RD3/4), turn them ON in the program.
  - The remote device station initialization procedure registration completion status (SB005F) does not turn ON unless all of initial processing for the stations specified in the remote device station initialization procedure registration station specification (SW0014 to SW0017) is completed normally.  
If any error station exists, turn OFF the remote device station initialization procedure registration instruction (SB000D) depending on the status of the other stations.
  - The remote device station initialization procedure registration is not allowed for the standby master station.  
When replacing a remote device station while the standby master station is operating as a master, perform initial setting on the program.
-



## (6) Link special relays and registers (SB/SW) relating to remote device station initialization procedure registration

The following shows the list of the link special relays and registers relating to the remote device station initialization procedure registration.

For more details, refer to  Page 409, Appendix 3.

Link special relay/register	Number	Name
Link special relay	SB000D	Remote device station initialization procedure registration instruction
	SB005E	Execution status of remote device station initialization procedure
	SB005F	Completion status of remote device station initialization procedure
Link special register	SW0014	Specification of remote device station to be initialized
	SW0015	
	SW0016	
	SW0017	
	SW005F	Remote device station initialization procedure registration instruction result
	SW0110	Remote device station initialization procedure registration execution individual information (target 1)
	SW0111	Remote device station initialization procedure registration execution individual information (target 2)
	SW0112	Remote device station initialization procedure registration execution individual information (target 3)
	SW0113	Remote device station initialization procedure registration execution individual information (target 4)
	SW0114	Remote device station initialization procedure registration execution individual information (target 5)
	SW0115	Remote device station initialization procedure registration execution individual information (target 6)
	SW0116	Remote device station initialization procedure registration execution individual information (target 7)
	SW0117	Remote device station initialization procedure registration execution individual information (target 8)
	SW0118	Remote device station initialization procedure registration execution individual information (target 9)
	SW0119	Remote device station initialization procedure registration execution individual information (target 10)
	SW011A	Remote device station initialization procedure registration execution individual information (target 11)
SW011B	Remote device station initialization procedure registration execution individual information (target 12)	
SW011C	Remote device station initialization procedure registration execution individual information (target 13)	
SW011D	Remote device station initialization procedure registration execution individual information (target 14)	
SW011E	Remote device station initialization procedure registration execution individual information (target 15)	
SW011F	Remote device station initialization procedure registration execution individual information (target 16)	

## 8.3.2 Event issuance for the interrupt program

This function issues events (signals to execute an interrupt program) according to factors such as the on/off status of specified RX, RY and SB devices and the match/mismatch status of specified RWr and SW device data, in order to allow the programmable controller CPU to execute the interrupt program. This enables the high speed receive processing without being influenced by the sequence scan.

Because the conditions for issuing the events are set using GX Works2, the number of program steps is reduced, thus shortening the sequence scan time.

Events can be issued to all stations.

A maximum of 16 event issuance conditions can be set.

### (1) Event issuance conditions

Events are issued under the following conditions:

On/off status of specified RX, RY and SB devices

Match/mismatch status of specified RWr and SW device data

When the link scan is completed

### (2) Event issuance condition setting method

#### (a) First, set the "Interrupt Setting" in the network parameter setting.

If interrupt conditions are established when the link scan is completed, the interrupt is issued. If "Scan Completed" is set to "Device Code", the interrupt is issued without conditions when the link scan is completed.

#### 1. Input format

Set the data input format for "Word Device Setting Value".

Setting range:	DEC.
	HEX.
Default:	DEX.

#### 2. Device code

Set the device to be used for the event issuance conditions.

Setting range:	RX
	SB
	RY
	RWr
	SW
	Scan Completed

#### 3. Device No.

Set the device number to be used for the event issuance conditions.

Setting range:	When RX or RY is selected: 0 to 1FFF (H)
	When SB or SW is selected: 0 to 01FF (H)
	When RWr is selected: 0 to 07FF (H)

#### 4. Detection method

Set the detection method for the event issuance conditions.

Setting range:	Edge Detect (Issues event only at rise and fall.)
	Level Detect (Issues each link scan event when the event issuance conditions are established.)

**5. Interrupt condition**

Set the conditions under which events are issued.

Setting range:	When RX, SB or RY is selected ON/OFF
	When RWr or SW is selected Equal/Unequal

**6. Word device setting value**

Set the conditions under which events are issued when RWr or SW is selected.

Setting range:	0 to 65535 (Decimal)
	0 to FFFF (Hexadecimal)

**7. Interrupt (SI) No.**

Set the intelligent function module interrupt pointer number.

(SI is an interrupt pointer for an intelligent function module and not a device used in an actual program.)

Setting range: 0 to 15

	Device Code	Device No.	Detection Method	Interrupt Condition	Word Device Setting Value	Channel No./Connection No.	Interrupt (SI) No.
1	RX	0000	Edge Detect	ON			0
2	RWr	0004	Level Detect	Unequal	150		1
3	Scan Completed						2
4							
5							
6							
7							
8							
9							
10							
11							
12							
13							
14							
15							
16							

**Point**

Only one event issuance condition can be set for each interrupt program.

**(b) Select "PLC Parameter" -- "PLC System" -- "Intelligent Function Module Setting" -- "Interrupt Pointer Setting".**

**1. "Interrupt Pointer Start No." on the PLC side.**

Set the interrupt pointer start number for the CPU.

Setting range: 50 to 255

**2. "Interrupt Pointer Count" on the PLC side**

Set the number of event issuance conditions specified in the "Interrupt Setting" of the network parameter setting

Setting range: 1 to 16

**3. "Start I/O No." on the intelligent module side**

Set the start input/output number for the intelligent function module for which the interrupt setting was performed.

Setting range: Within the range of I/O points of the CPU module



**(c) When multiple interrupts occur simultaneously**

The operation may delay.

**(d) Executing the interrupt program at rise or fall of the specified device**

Do not execute the interrupt program by using the rise (using the PLS instruction) or fall (using the PLF instruction) of the specified device because the device change may not be recognized.

**Ex** The interrupt request is executed by turning on RX10

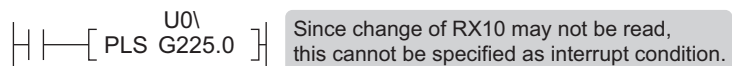

**(e) When the interrupt cannot be performed**

If the changing time of the device used for the interrupt condition is shorter than the transmission delay time, the device change cannot be detected.

**(f) When using data for the interrupt program**

When the interrupt program is being executed, RX/RY/RWr/RWw are not auto refreshed to the device of the CPU module. Therefore, directly access to the buffer memory of the L series master/local module by using Intelligent function module device Un\G□.

**(g) When the data link is faulty**

The interrupt request to the CPU module is not performed

**(4) Simulation of the interrupt program**

When the event issuance conditions are established in the master station using GX Works2, the interrupt program is executed even when the corresponding modules are not connected, and then the interrupt program can be simulated.

**Ex** An event is issued when RX01 turns on, and then an interrupt program is executed.

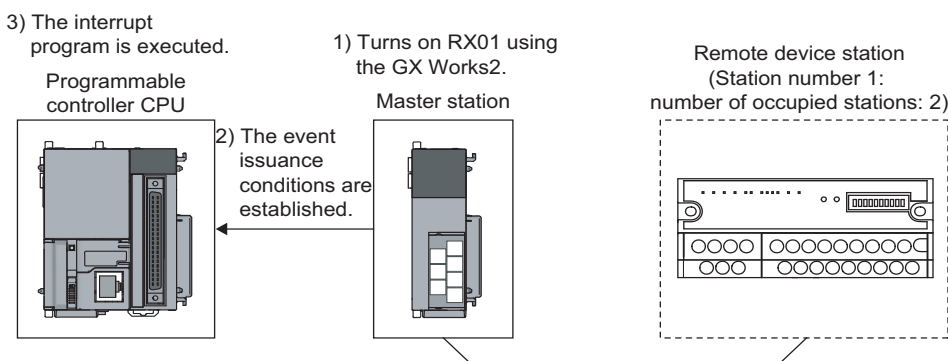

## 8.3.3 Automatic CC-Link startup

When in a system configuration including not only remote I/O stations but also remote device stations and intelligent device stations, the CC-Link startup and data refresh are performed only by powering up the system and without creating a program for it.

Use this function to check the operation when constructing a system. When performing control, always set the network parameters.

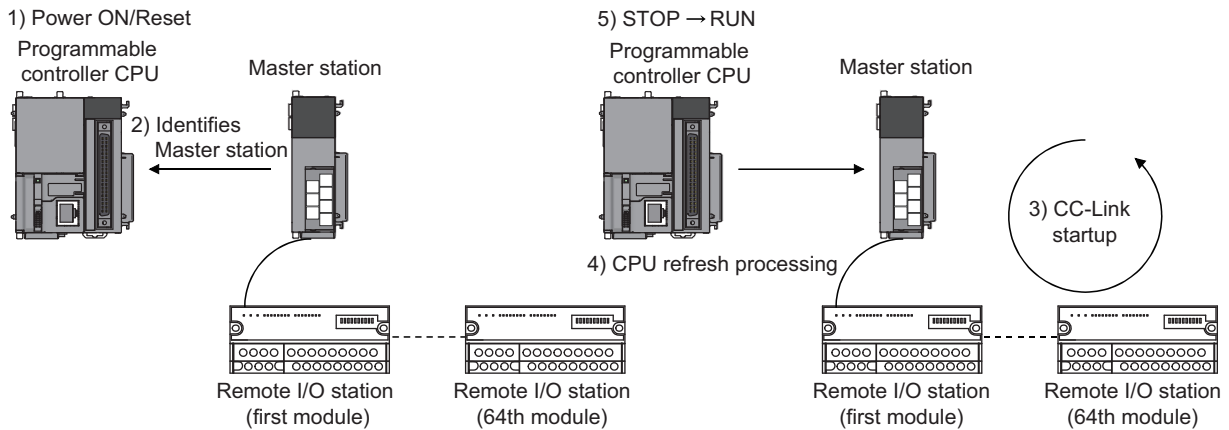

### (1) Default parameter settings at automatic CC-Link startup

The following lists the default automatic refresh parameter settings, the network parameter settings and the buffer memory size specifications for the intelligent device stations when the automatic CC-Link starts up.

#### (a) Content of default automatic refresh parameter settings

LCPU	Direction	Master station
X1000 to X17FF	←	RX0000 to RX07FF
Y1000 to Y17FF	→	RY0000 to RY07FF
W1E00 to W1EFF	←	RWr00 to RWrFF
W1F00 to W1FFF	→	RWw00 to RWwFF
SB0600 to SB07FF	←	SB0000 to SB01FF
SW0600 to SW07FF	←	SW0000 to SW01FF

#### (b) Default network parameter settings

Type	Master station
Mode	Remote Net (Ver.1 Mode)
Transmission Speed	156kbps
Total Module Connected	64 modules
Retry Count	3 times
Automatic Reconnection Station Count	1 module
Standby Master Station No.	No standby master station specified.
PLC Down Select	Data link stop when a master station CPU error occurs
Scan Mode Setting	Asynchronous
Delay Time Setting	0

**(c) Default operation setting**

Item	Description
Data Link Faulty Station Setting	Clear the input data.
Case of CPU STOP Setting	Refresh.
Block Data Assurance per Station	Disable the setting.

**(d) Buffer memory size specification for intelligent device station**

Send buffer	64 words
Receive buffer	64 words
Automatic update buffer	128 words

**Point**

- Perform an automatic CC-Link startup in the following settings.
  - Master station
  - Remote net Ver.1 mode
  - Transmission speed: 156kbps
- Make sure to perform loop tests by GX Works2 for all stations if an automatic CC-Link startup is performed and changes such as replacement of a module, etc. are made to the system during data link operation.  
Stations whose data link has already been established (only stations whose station numbers overlap) may also go down if stations with overlapping head station numbers return to the system.
- If an automatic CC-Link startup was performed, a temporary error invalid station cannot be used.
- The device on the LCPU in the contents of the default automatic refresh parameter settings is changed with device points of "PLC Parameter" - "Device" at the automatic CC-Link startup. If no refresh device exists, the auto refresh is not performed.  
If the auto refresh is not performed when the SM319 of the CPU module is in off status, check the device points assignment of the CPU module.

**(2) Execution conditions****(a) When a CPU module without built-in CC-Link function is connected**

The automatic CC-Link startup function is applicable only to one "LJ61BT11".

When two or more LJ61BT11s are mounted, the automatic CC-Link startup function is applicable only to the LJ61BT11 that has the smallest start I/O number.

**(b) When a CPU module with built-in CC-Link function is connected**

The automatic CC-Link startup function is applicable only to one L series master/local module.

When the LJ61BT11 is mounted, the automatic CC-Link startup function is applicable only to one L series master/local module that has the smallest start I/O number. (When the default values are set to the I/O assignment setting window, the automatic CC-Link startup function is applicable to the built-in CC-Link function.)

## 8.3.4 Reserved station function

This function prevents slave stations that are not actually connected (but to be connected in the future) from being treated as "data link faulty stations" by the master station and local stations.

When the master station is placed in the remote net ver.2 mode, points for reserved stations can be set to 0.

Use GX Works2 to set 0 points for reserved stations.

Although dedicated instructions are not usable for this setting, if reading from or writing to reserved stations is disabled when refreshing cyclic data with FROM/TO instructions, the same result is obtained.

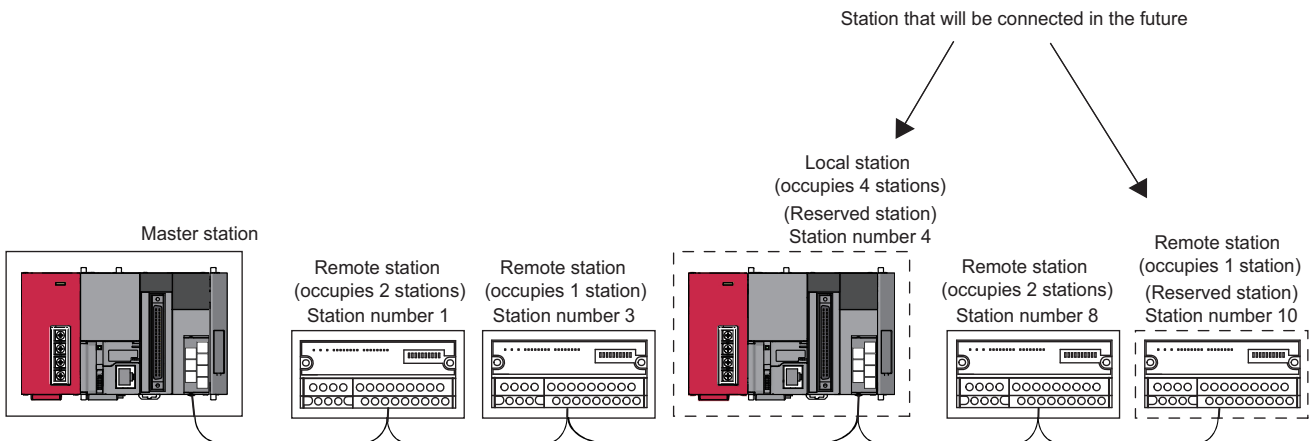

If a connected slave station is specified as a reserved station, data link with the specified slave station becomes disabled.

[Setting method]

Set the reserved function in "Station Information Setting" of the network parameter setting in GX Works2.

(Refer to  Page 83, Section 7.3.2 (2).)

- Make reserved station setting by choosing "Station Information Setting" - "Reserve/Invalid Station Select".
- Make 0 points setting for the reserved station by choosing "Station Information Setting" - "Remote Station Points".



## 8.3.5 Error invalid station setting function

This function prevents slave stations that are powered off in the system configuration from being treated as "data link faulty stations" by the master station and local stations, using the network parameter settings.

Note that if a station is set as an error invalid station, problems occurring in that station can no longer be detected. In addition, the error invalid station settings cannot be changed while online because they are set with the network parameters.

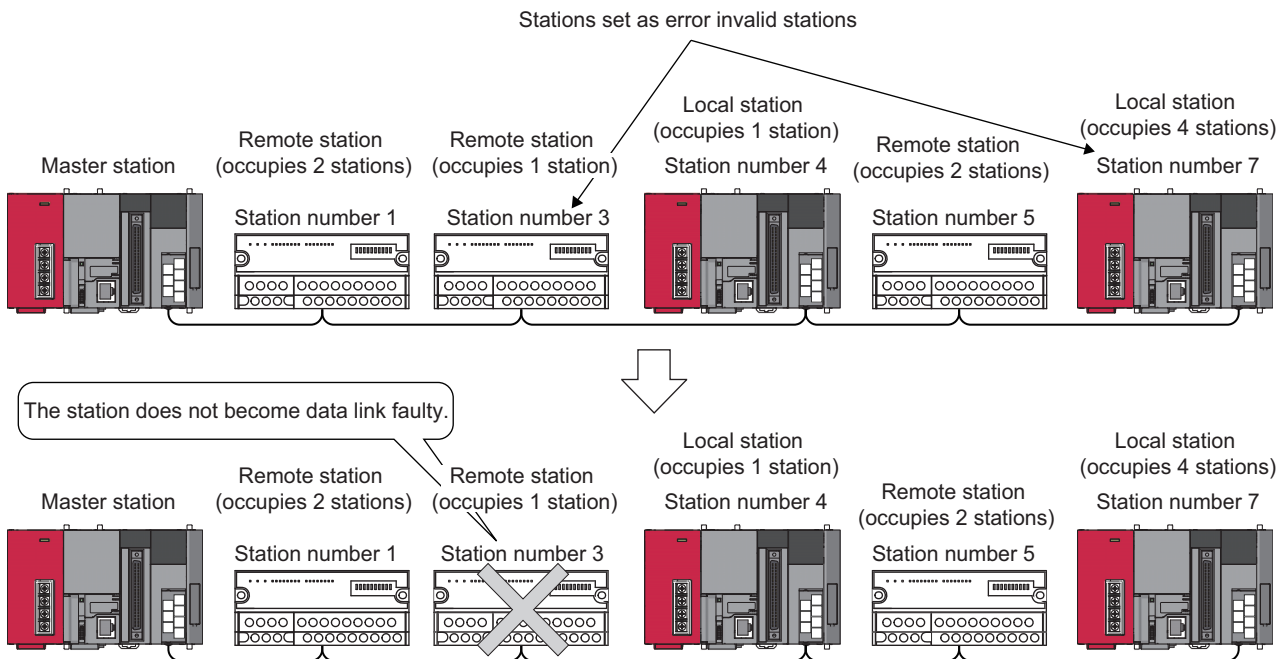

### Point

- If a slave station that is set as an error invalid station is "specified as a reserved station," the reserved station function overrides the error invalid station setting function.
- If errors are generated at all the stations when they are set as error-invalid stations, the "ERR." LED will light.

#### [Setting method]

Set the reserved function in "Station Information Setting" of the network parameter setting in GX Works2.

(Refer to  Page 83, Section 7.3.2 (2).)

## 8.3.6 Temporary error invalid station setting function

This function allows the replacement of modules while online, without error detection.

Also, this function prevents slave stations, which are turned off in the system configuration, from being treated as "data link faulty stations" temporarily.

### (1) Setting method

Set the [Diagnostics] ⇨ [CC-Link Diagnostics] using GX Works2.

1. Select a station from the station list.
2. Execute with right click ⇨ Shortcut menu ⇨ [Set/Cancel Temporary Error Invalid Station].

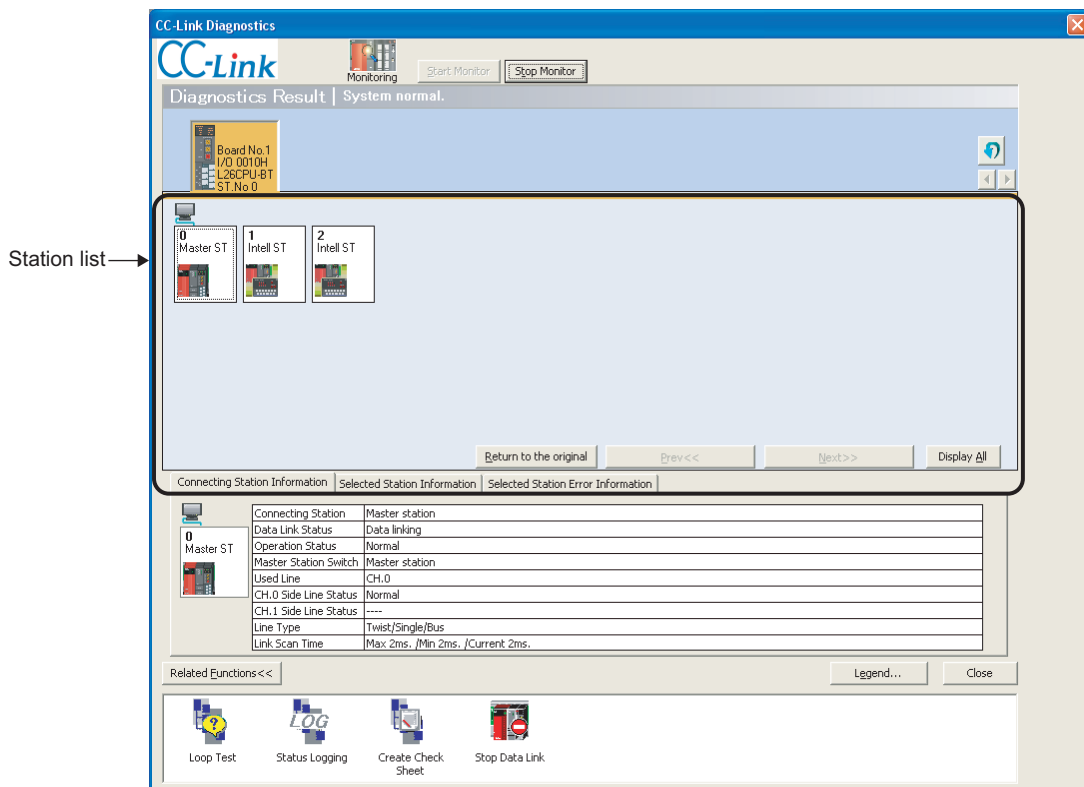

## (2) Precautions

### (a) Precautions when temporary error invalid station setting is executed

- Do not write to buffer memory addresses 5E0<sub>H</sub>, and 603<sub>H</sub> to 607<sub>H</sub>.
- Do not execute at one time by programs and other peripherals.

If executed at one time, temporary error invalid station setting may not operate normally.

### (b) Input/output status at temporary error invalid station setting

All the cyclic transmission data of the stations set as temporary error-invalid stations is refreshed.

However, when a station set as a temporary error-invalid station becomes faulty, the input is retained and the output switches off.

### (c) When multiple stations are set as occupied stations, the temporary error invalid station setting must be executed specifying the starting station number for each occupied station. If executing temporary error invalid station setting to a station which is not the starting station in the actual assignment, the invalid setting is ignored.

## 8.3.7 Scan synchronous function

This function selects whether to synchronize or not the link scan with the sequence scan.

### (1) Synchronous mode

Performs data linking using the scan that is synchronized with the program.

(The sequence scan and link scan start at the same time.)

In the synchronous mode, the link scan interval becomes longer when the sequence scan takes long because the link scan is synchronized with the sequence scan.

#### **Point**

- While in the synchronous mode, the sequence scan time must not exceed the time specified for the corresponding transmission speed, as listed below.

If the scan time exceeds the specified time, a time out error occurs at each station.

Transmission speed	Sequence scan time
10Mbps	50ms
5Mbps	50ms
2.5Mbps	100ms
625kbps	400ms
156kbps	800ms

- The asynchronous mode is recommended for a mixed system of local stations A1SJ61BT11 and A1SJ61QBT11 when the L series master/local module is used as the master station.  
When using a system that uses the L series master/local module as the master station in the synchronous mode, make sure to observe the restrictions in (a) and (b) below.
  - When using a system consisting of both the A1SJ61BT11 and A1SJ61QBT11 as local stations, set the sequence scan time of the local station CPU to be shorter than ST.  
For more details on "ST", refer to  Page 430, Appendix 4.1.
  - When using a system consisting of the QJ61BT11N as the master station in the synchronous mode and both the A(1S)J61BT11 and A(1S)J61QBT11 as local stations, use XnC as an interlock of the FROM/TO instructions on the local station CPU side.
- When operating in the synchronous mode, the "L RUN" LED may be lit dimly.

### (2) Asynchronous mode

Performs data linking without synchronizing with the program.

### (3) Setting method

Set the scan synchronous function in "Scan Mode Setting" of the network parameter setting in GX Works2. (Refer to  Page 77, Section 7.3.2 to Page 99, Section 7.4.2.)

#### (4) Data flows in synchronous and asynchronous modes

The data flows in both the synchronous and asynchronous modes are explained using examples of communications between the master station and remote I/O stations.

##### Point

Even if latched device (listed in "CPU side device" in the table below) data are cleared to 0 by a program at reset of the CPU module or at power off and on, the latched data may be output depending on the timing of link scan and link refresh. For how to prevent output of latched device data, perform "Method for disabling output" listed in the table below.

CPU side device	Method for disabling output
Latch relay (L)	Clear the value of the device to 0 using the initial device value. For how to set an initial device value, refer to the MELSEC-L CPU Module User's Manual (Function Explanation, Program Fundamentals).
File register (R, ZR)	
Extended data register (D)	Delete all latch range settings.
Extended link register (W)	
Device in the latch range	

##### (a) Data flow in the asynchronous mode

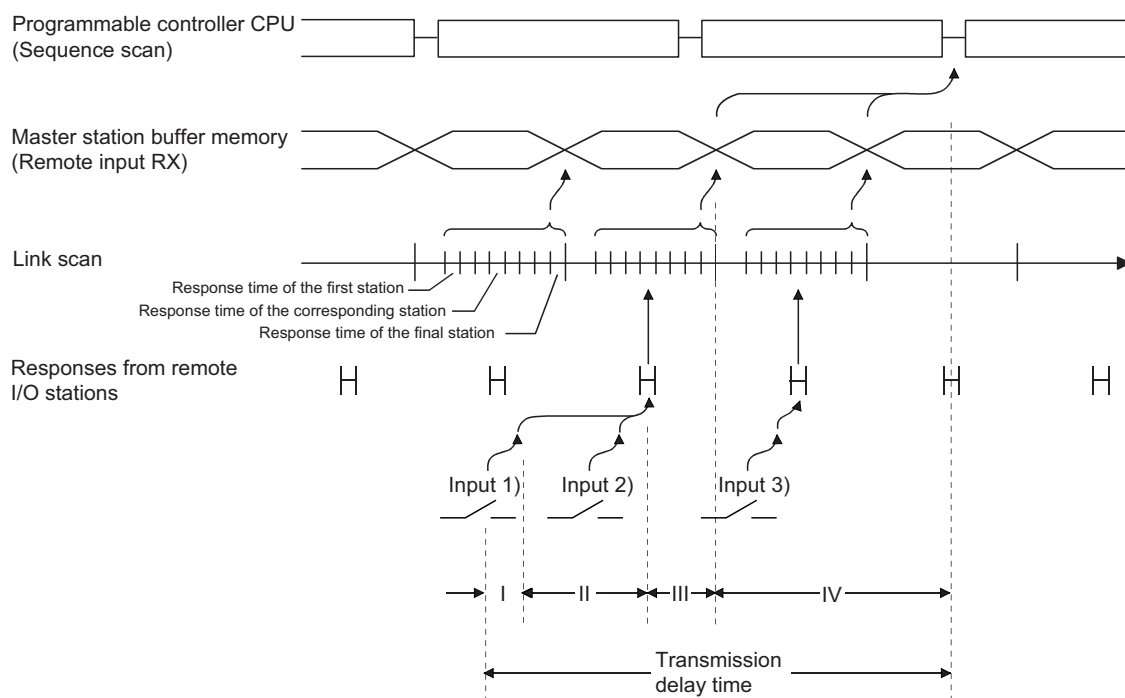

I: Delay time due to response delay of remote I/O station

II: Delay time of transmission from the remote I/O station to the master station

III: Delay time from reception by the master station to storage in the buffer memory

IV: Delay time until the master station's information is refreshed in the programmable controller CPU

**(b) Data flow in the synchronous mode**

- Sequence scan  $\geq$  Link scan

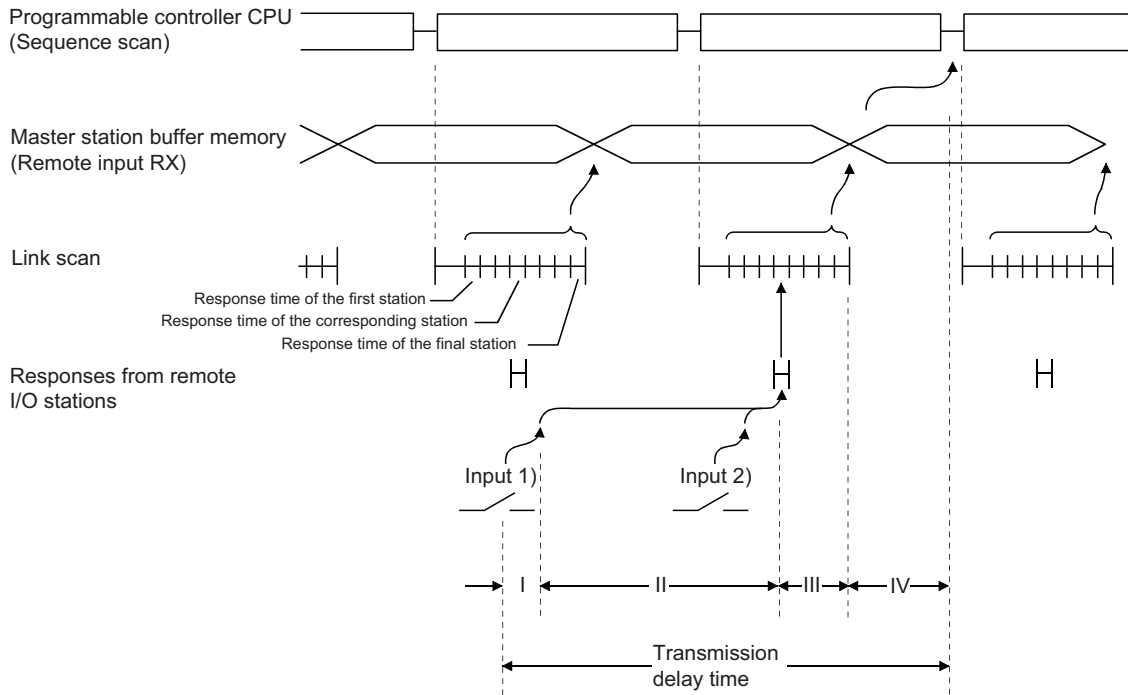

I: Delay time due to response delay of remote I/O station

II: Delay time of transmission from the remote I/O station to the master station

III: Delay time from reception by the master station to storage in the buffer memory

IV: Delay time until the master station's information is refreshed in the programmable controller CPU

- Sequence scan < Link scan

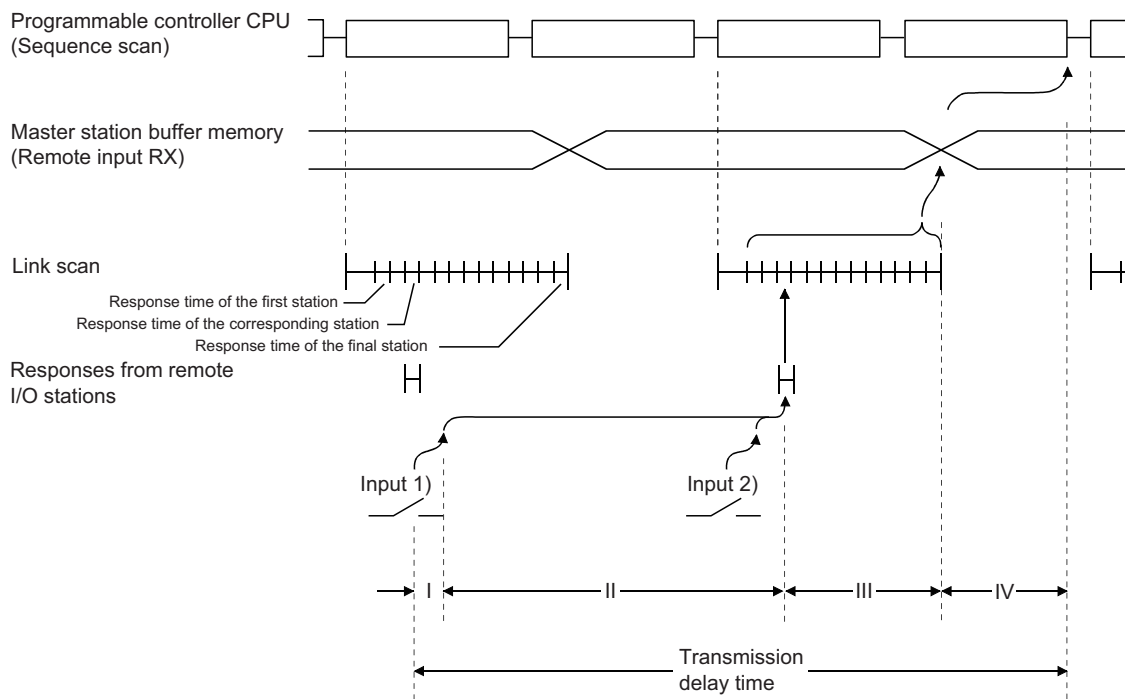

- I: Delay time due to response delay of remote I/O station
- II: Delay time of transmission from the remote I/O station to the master station
- III: Delay time from reception by the master station to storage in the buffer memory
- IV: Delay time until the master station's information is refreshed in the programmable controller CPU

## 8.3.8 Data link stop/restart

This function stops and restarts local data links.

If the data link is stopped, programs can be efficiently debugged, since other stations data are not received and host station data are not sent.

If the data link of the master station is stopped, the data link of the entire system stops.

### (1) Setting method

Set the [Diagnostics] ⇒ [CC-Link Diagnostics] using GX Works2.

- 1) Select the module to stop/restart data links on "Module list/diagnosis object select".
- 2) Execute "Start Data Link" or "Stop Data Link" in Related functions, by double-clicking it.

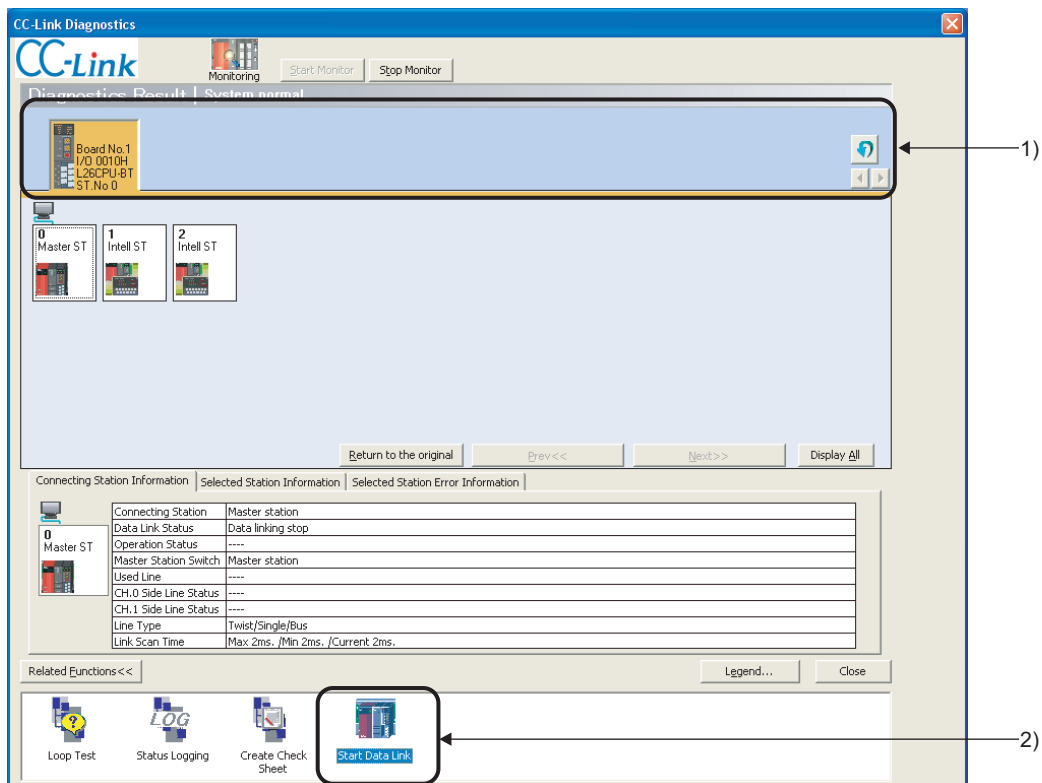



## (2) Precautions

### (a) Precautions when executing data link stop/restart

- Do not write to buffer memory address 5E0<sub>H</sub>.
- Do not execute at one time by programs and other peripherals.  
If executing at one time, data link stop/restart may not operate normally.

### (b) If executing "Stop Data Link" at the master station when GX Works2 is connected to a local station as the following system configuration, data link in the whole system stops and the transmission from GX Works2 to the master station cannot be operated via CC-Link.

To restart the transmission from GX Works2, reset the programmable controller CPU of the data link stop station and restart data link.

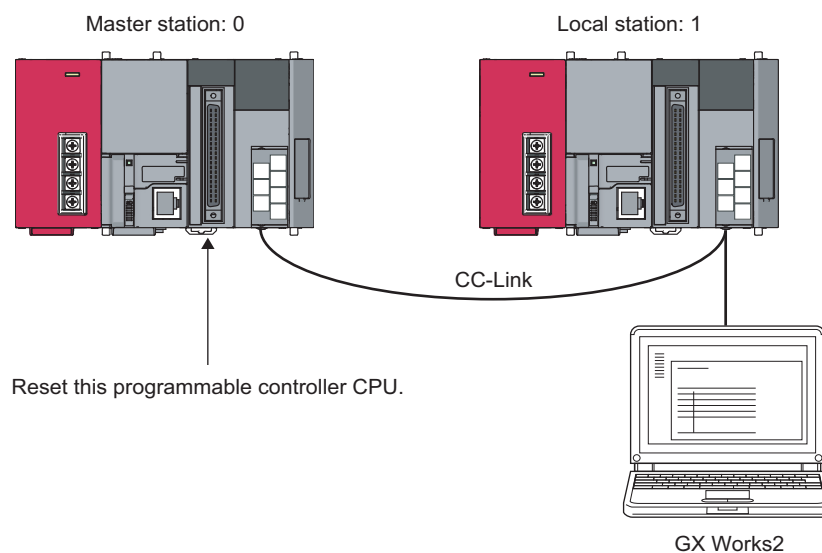

## 8.3.9 Remote I/O station points setting

The points of each remote I/O station can be set to 8, 16 or 32 points.

This saves the refresh device points of the programmable controller CPU and link refresh time.

The remote I/O station points setting can be used in the remote net ver. 2 mode only.

For parameter setting, use GX Works2.

This function cannot be executed if the dedicated instruction is used for parameter setting. This function can be executed when read/write from/to the CPU devices is performed according to the I/O points of each station at cyclic data refresh using the FROM/TO instruction.

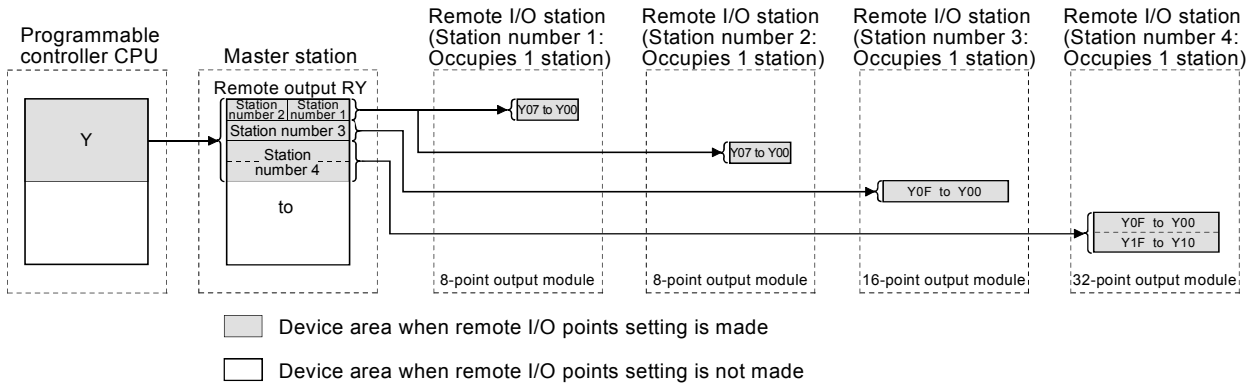

### Point!

Set points to even-numbered 8-point setting remote I/O stations consecutively. If points are set to odd-numbered 8-point setting remote stations, select 8 points + 8 points reserved in the "Remote Station Points" setting of the last of the consecutive remote I/O stations.

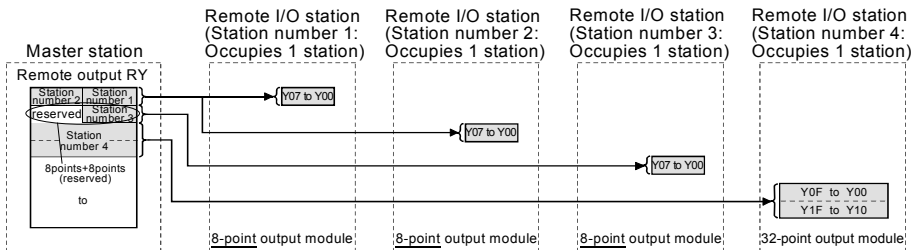

Odd-numbered 8-point setting remote stations cannot be set for 8 remote station points.

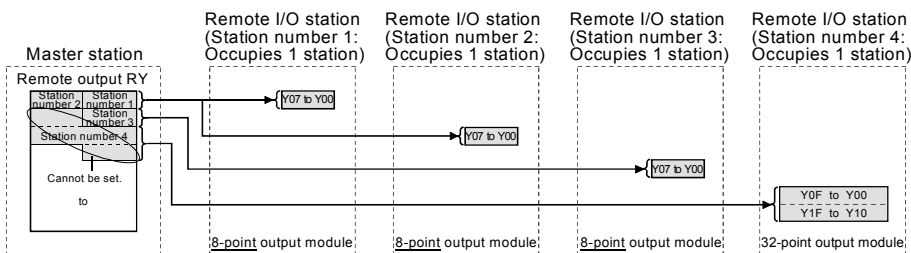

Refer to Page 77, Section 7.3.2 and Page 99, Section 7.4.2 for the parameter setting.

[Setting method]

Use GX Works2 to set "Station Information Setting" - "Remote Station Points" in the network parameter setting. (Refer to  Page 83, Section 7.3.2 (2).)

### (1) Precautions for setting the remote I/O station points

The number of parameter-set remote I/O station points should be equal to or greater than the number of I/O points of the mounted remote I/O stations. If it is less than the number of I/O points of the mounted remote I/O stations, the inputs/outputs after the set number of points will not operate normally.

## 8.3.10 Master station duplication error cancel function

This function cancels a master station duplication error without turning the power supply off to on, or without resetting the programmable controller CPU, if a master station duplication error is detected.

### (1) Removing the cause of error occurrence

Before performing the master station duplication error cancel function, remove the cause of error occurrence of the master station duplication error.

Another master station may exist in the same line, or the line may be affected by noises or others.

### (2) Link special relay/register (SB/SW) relating to the master station duplication error cancel function

After removing the cause of error occurrence of the master station duplication error, turn on SB0007 (master station duplication error canceling request).

The following shows the list of the link special relays and registers relating to the Master station duplication error cancel function.

For details, refer to  Page 409, Appendix 3.

Link special relay/register	Number	Name
Link special relay	SB0007	Master station duplication error canceling request
	SB0057	Master station duplication error canceling acknowledgement
	SB0058	Master station duplication error canceling complete
Link special register	SW0057	Master station duplication error canceling result

### (3) Timing chart of link special relay (SB) and link special register (SW)

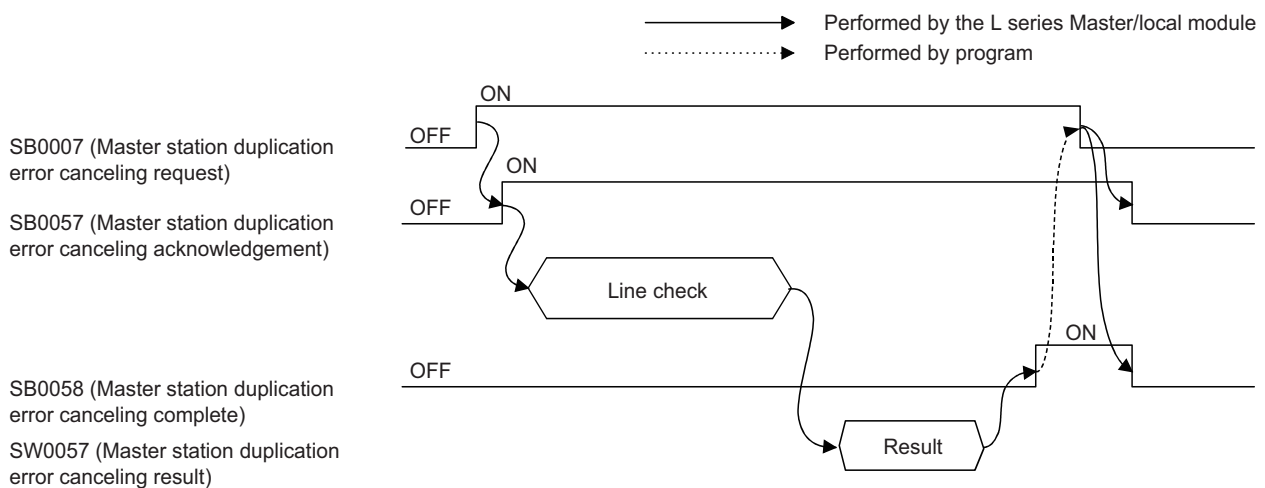

# CHAPTER 9 DEDICATED INSTRUCTIONS AND PROGRAMMING

The following explains precautions on dedicated instructions and programming.

## 9.1 Dedicated Instructions

Using dedicated instructions, the L series master/local module is capable of the transient transmission to local stations and intelligent device stations.

### 9.1.1 Dedicated instruction list, applicable devices, and precautions

#### (1) Dedicated instruction list

The following table lists the dedicated instructions that can be used for each of these stations:

Target station	Instruction	Description	Reference
Master station Local station	G(P).RIRD	Reads data from the buffer memory or the programmable controller CPU device of the specified station.	Page 193, Section 9.1.2
	G(P).RIWT	Writes data into the buffer memory or the programmable controller CPU device of the specified station.	Page 199, Section 9.1.3
Intelligent device station	G(P).RIRD	Reads data from the buffer memory of the specified station.	Page 193, Section 9.1.2
	G(P).RIWT	Writes data into the buffer memory of the specified station.	Page 199, Section 9.1.3
	G(P).RIRCV	Automatically performs handshaking with the specified station and reads data from the buffer memory of that station. Available for modules that have signals for the handshake (e.g. AJ65BT-R2N).	Page 205, Section 9.1.4
	G(P).RISEND	Automatically performs handshaking with the specified station and writes data into the buffer memory of that station. Available for modules that have signals for the handshake (e.g. AJ65BT-R2N).	Page 210, Section 9.1.5
	G(P).RIFR	Reads data in the automatic update buffer of the specified station. Available for modules that have the automatic update buffer (e.g. AJ65BT-R2N).	Page 215, Section 9.1.6
	G(P).RITO	Writes data into the automatic update buffer of the specified station. Available for modules that have the automatic update buffer (e.g. AJ65BT-R2N).	Page 218, Section 9.1.7
Master station	G(P).RLPASET	Sets the network parameters for the master station and starts up the data link.	Page 221, Section 9.1.8
Remote device station	G(P).RDMSG	Reads/writes parameters from/to the remote device station and reads the status of the remote device station. Available for communication with a remote device station that supports the message transmission function (e.g. NZ2AW1C2AL).	Page 236, Section 9.1.9

Execute the dedicated instructions while the data link is being performed.

If any of the dedicated instructions is executed offline, no error will occur, but the execution of the dedicated instruction will not be completed.

## (2) Available devices

The following devices are available for the dedicated instructions:

Internal devices		File register	Constant
Bit*1	Word		
X, Y, M, L, F, V, B	T, ST, C, D, W	R, ZR	K, H

- \*1 Word device bit designation can be used for bit data.  
 Word device bit designation is done by specifying [Word device] or [Bit No.].  
 (Bit numbers must be given in hexadecimal.)  
 For example, bit 10 of D0 is designated as [D0.A].  
 However, bit designation is not allowed for timers (T), retentive timers (ST) and counters (C).

## (3) Precautions

### (a) Precautions for using Monitoring time (SW0009) and Dedicated instruction retry count setting (SW000B)

- The Dedicated instruction retry count setting (SW000B) is applicable to the following dedicated instructions. (Refer to  Page 416, Appendix 3.2)

Instruction	Station executing dedicated instructions	
	Master station	Local station
G(P).RIRD	○	○
G(P).RIWT	○	○
G(P).RISEND	○	×
G(P).RIRCV	○	×
G(P).RIFR	×	×
G(P).RITO	×	×
G(P).RLPASET	×	×

○: Applicable, ×: N/A

Set the Dedicated instruction retry count setting when the error completion device turns ON due to noise. If this setting is made, frequency of this turn-ON will be greatly reduced. Note that no retry is performed when the target station has been disconnected at the time of dedicated instruction execution.

- Before execution of dedicated instructions, set the Monitoring time (SW0009) and Dedicated instruction retry count setting (SW000B).

## 9.1.2 G(P).RIRD

The G(P).RIRD instruction reads the specified points of data from the buffer memory or the programmable controller CPU device of the specified station.

Set data	Usable devices									
	Internal device (System, user)		File register	Link direct device J□□		Intelligent function module device U□\G□	Index register Z□	Constant		Other
	Bit	Word		Bit	Word			K, H	\$	
(S)	—	○			—			—	—	—
(D1)	—	○			—			—	—	—
(D2)		○			—			—	—	—

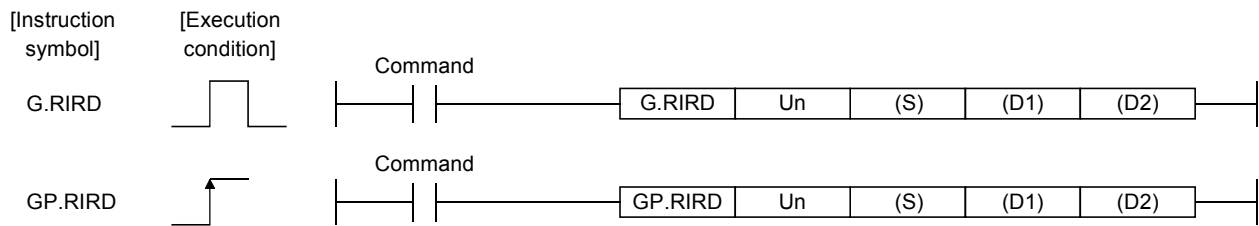

Set data

Device <sup>*1</sup>	Description	Setting range	Data type
Un	Start I/O number of the module (First 2 digits of I/O No. with three digits)	0 to FE <sub>H</sub>	Binary 16 bits
(S)	Start number of the device in which control data is stored.	Within the range of the specified device	Device name
(D1)	Start number of the device to which read data is to be stored.	Within the range of the specified device	
(D2)	Device that is turned ON for one scan upon completion of reading. (D2) + 1 also turns ON at an abnormal completion.	Within the range of the specified device	Bit

\*1 The file register of each of the local device and the program cannot be used as a device for setting data.

Control data

Device	Item	Set data	Setting range	Set by
(S) + 0	Completion status	Stores the status when the instruction is complete. 0: No error (normal completion) Other than 0: Error code	—	System
(S) + 1	Station number	Specify the station numbers of the master station, local station and intelligent device station.	0 to 64	User
(S) + 2	Access code Attribute code	<p>The diagram shows a horizontal row of 16 small boxes representing bits. The first 8 boxes are labeled 'b15' at the top left and 'b8' at the top right. The next 8 boxes are labeled 'b7' at the top left and 'b0' at the top right. Below the first 8 boxes is a double-headed arrow labeled 'Access code'. Below the next 8 boxes is a double-headed arrow labeled 'Attribute code'.</p>	Page 195, Section 9.1.2 (1), Page 195, Section 9.1.2 (2)	User
(S) + 3	Buffer memory address or device number	Specify the buffer memory start address or device start number.	*1	User
(S) + 4	Number of points to read	Specify the read data count (in word units).	1 to 480* <sup>2</sup> 1 to 32* <sup>3</sup>	User

\*1 For details, refer to the manual for the local station or the intelligent device station from which data are read.

When the random access buffer is specified, specify the start address of the random access buffer as 0.

\*2 The value indicates the maximum number of data to be read.

Specify the value within the buffer memory capacity of the local station or the intelligent device station, or the receive buffer area setting range set by a parameter.

\*3 When reading device data from the programmable controller CPU other than the QCPU, LCPU, QnACPU or AnUCPU, the setting range shall be 1 to 32 words.



**(1) Buffer memory in the CC-Link**

Buffer Memory contents		Access code	Attribute code
Buffer in the intelligent device station		00 <sub>H</sub>	04 <sub>H</sub>
Buffers in master station and local station	Random access buffer	20 <sub>H</sub>	
	Remote input	21 <sub>H</sub>	
	Remote output	22 <sub>H</sub>	
	Remote register	24 <sub>H</sub>	
	Link special relay	63 <sub>H</sub>	
	Link special register	64 <sub>H</sub>	

**(2) Device memory in the programmable controller CPU**

Device contents	Name	Device type		Unit	Access code	Attribute code
		Bit	Word			
Input relay	X	○	—	Hexadecimal	01 <sub>H</sub>	05 <sub>H</sub>
Output relay	Y	○	—	Hexadecimal	02 <sub>H</sub>	
Internal relay	M	○	—	Decimal	03 <sub>H</sub>	
Latch relay	L	○	—	Decimal	83 <sub>H</sub>	
Link relay	B	○	—	Hexadecimal	23 <sub>H</sub>	
Timer (contact)	T	○	—	Decimal	09 <sub>H</sub>	
Timer (coil)	T	○	—	Decimal	0A <sub>H</sub>	
Timer (present value)	T	—	○	Decimal	0C <sub>H</sub>	
Retentive timer (contact)	ST	○	—	Decimal	89 <sub>H</sub>	
Retentive timer (coil)	ST	○	—	Decimal	8A <sub>H</sub>	
Retentive timer (present value)	ST	—	○	Decimal	8C <sub>H</sub>	
Counter (contact)	C	○	—	Decimal	11 <sub>H</sub>	
Counter (coil)	C	○	—	Decimal	12 <sub>H</sub>	
Counter (present value)	C	—	○	Decimal	14 <sub>H</sub>	
Data register	D	—	○	Decimal	04 <sub>H</sub>	
Link register	W	—	○	Hexadecimal	24 <sub>H</sub>	
File register	R	—	○	Decimal	84 <sub>H</sub>	
Link special relay	SB	○	—	Hexadecimal	63 <sub>H</sub>	
Link special register	SW	—	○	Hexadecimal	64 <sub>H</sub>	
Special relay	SM	○	—	Decimal	43 <sub>H</sub>	
Special register	SD	—	○	Decimal	44 <sub>H</sub>	

Devices other than shown above cannot be accessed.

When accessing a bit device, specify it with 0 or a multiple of 16.

The extended data register of address D65536 or higher, and the extended link register of address W10000 or higher cannot be specified.

### (3) Functions

#### (a) Operation chart for the RIRD instruction

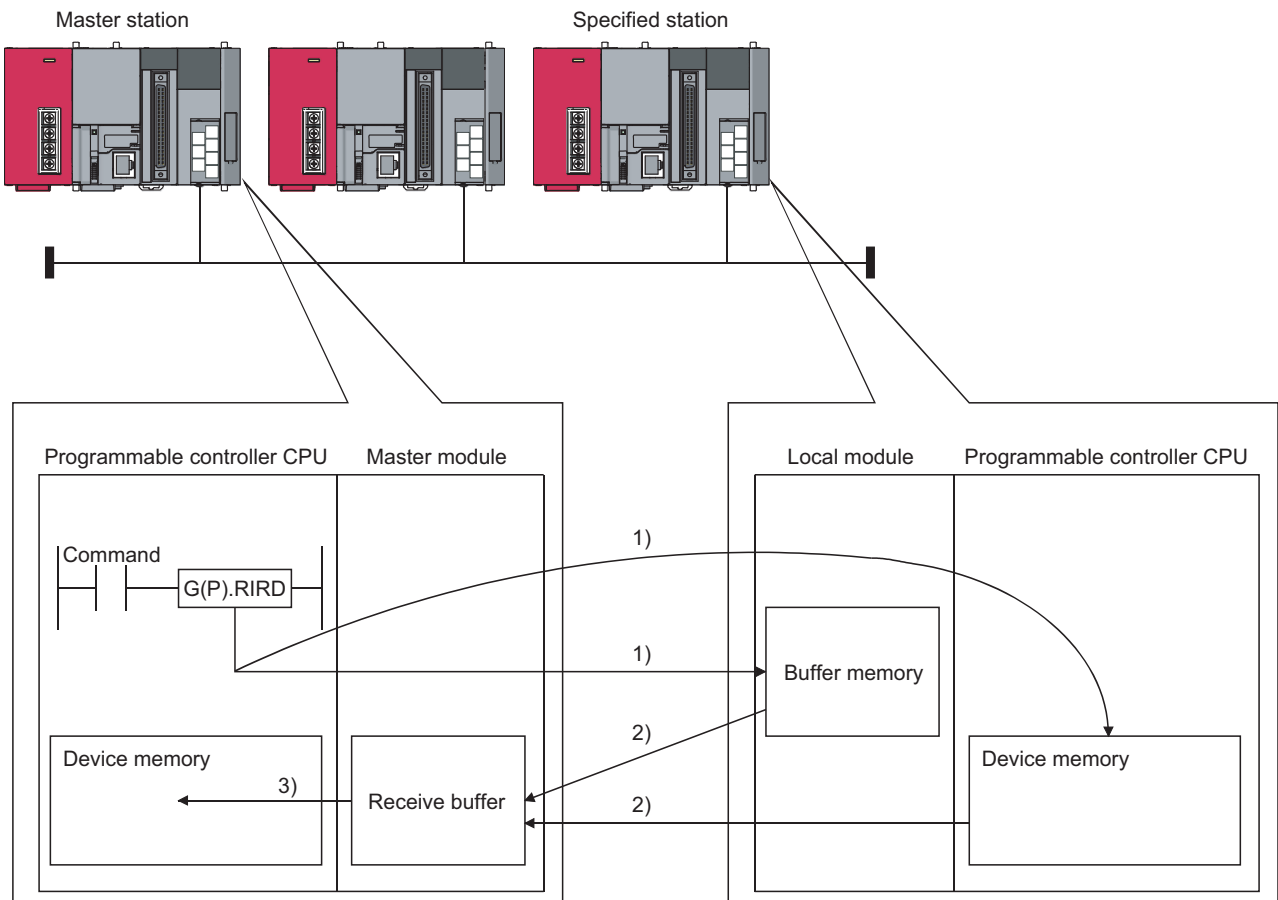

1. Accesses the buffer memory specified by (S)+2 and (S)+3 of the station specified by (S)+1, or the programmable controller CPU device.
2. Stores the data that has been read in the receive buffer of the master module.
3. Stores the data that has been read after the device specified in (D1), and the device specified by (D2) turns on.

#### (b) The G(P).RIRD instruction can be executed to multiple local stations or intelligent device stations simultaneously.

Note that concurrent execution of multiple instructions including other dedicated instruction(s) (refer to  Page 191, Section 9.1) is not allowed to the same local station or intelligent device station.

Create a program in which a flag remains on until the instruction is completed.

**(c) There are two types of interlock signals for the G(P).RIRD instruction: the completion device (D2) and status display device at completion (D2) + 1.**

- Completion device  
Turns ON in the END processing of the scan where the G(P).RIRD instruction is completed, and turns OFF in the next END processing.
- Status display device at completion  
Turns ON and OFF depending on the completion status of the G(P).RIRD instruction.  
Normal completion: Stays OFF and does not change.  
Abnormal completion: Turns ON in the END processing of the scan where the G(P).RIRD instruction is completed, and turns OFF in the next END processing.

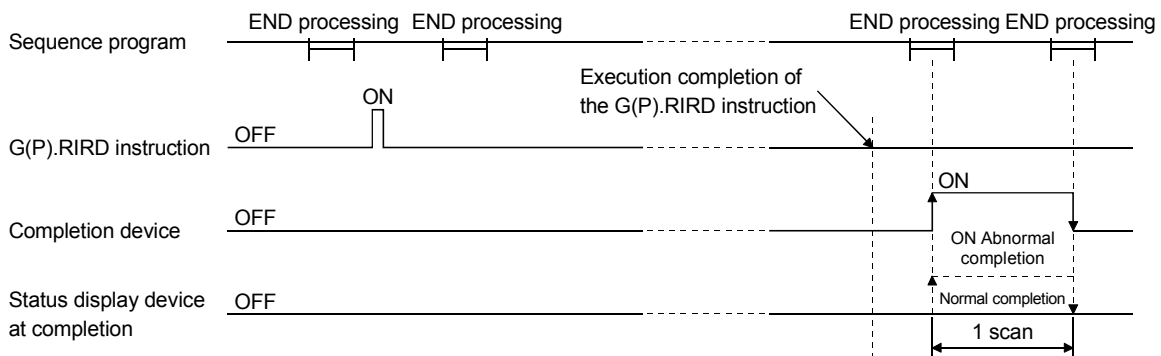

**(d) Multiple dedicated instructions cannot be executed for the same station.**

Since it takes several scans until the processing of the dedicated instruction is completed, execute the next dedicated instruction after the completion device has turned ON.

The next dedicated instruction executed before completion of the previously executed dedicated instruction is ignored.

**(e) The basic number of steps of the G(P).RIRD instruction is 8 steps.**

**(f) Use GX Works2 to assign receive buffer in "Station Information Setting" in the "Network Parameter" window.**

For more details on the setting, refer to  Page 83, Section 7.3.2 (2).

**(4) Operation error**

In the following cases, an operation error occurs; the error flag (SM0) turns ON and the error code is stored in SD0.

Error code	Description of operation error
2112	When the module specified by Un is not an intelligent function module.
	When the module specified by Un is not a special function module.
4002	When an attempt was made to execute an unsupported instruction.
4003	When the number of devices in the instruction is incorrect.
4004	When the instruction specifies a device that cannot be used.
4100	When the instruction contains the data that cannot be used.
4101	When the number of data set to be used exceeds the allowable range.
	Or, when the storage data or constants of the device specified with the instruction exceeds the allowable range.

### (5) Program example

When X0 is turned ON, 10-word data are stored from the area starting D1000 in a local station (station No.1), which is connected to the master module in the I/O No. position of X/Y40 to X/Y5F, into the area starting from D0. (When the link special register (SW) refresh device is set to SW0000) M12 is the RIRD instruction executing flag.

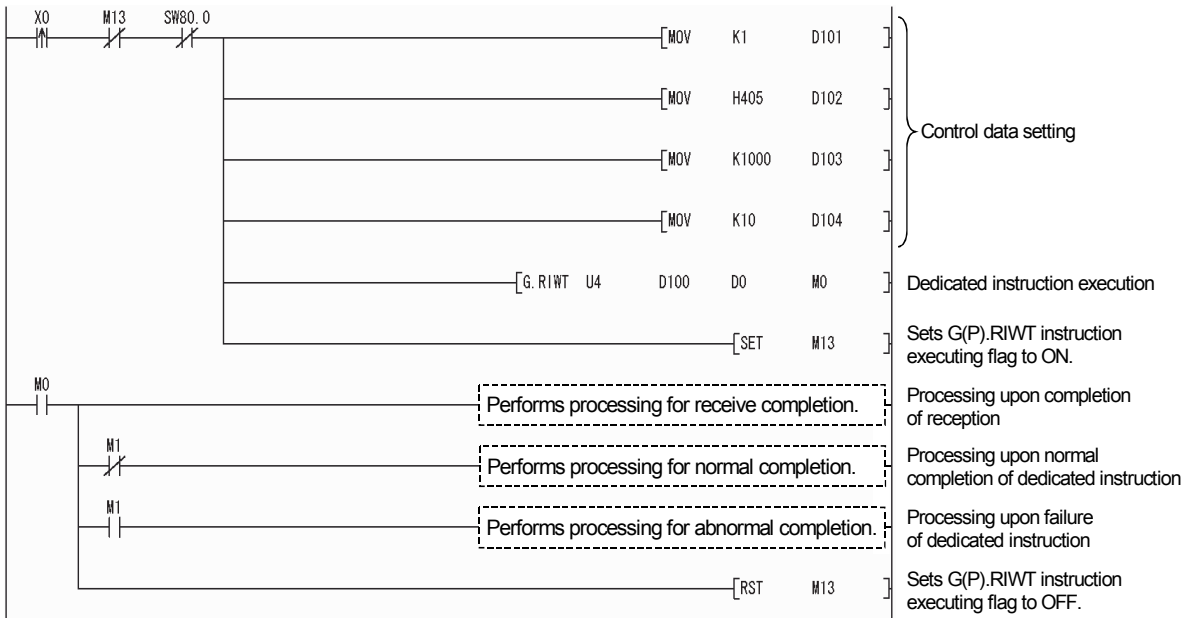

### 9.1.3 G(P).RIWT

The G(P).RIWT instruction writes the specified points of data, to the buffer memory or the programmable controller CPU device of the specified station.

Set data	Usable devices									
	Internal device (System, user)		File register	Link direct device J□\□		Intelligent function module device U□\G□	Index register Z□	Constant		Other
	Bit	Word		Bit	Word			K, H	\$	
(S1)	—	○			—			—	—	—
(S2)	—	○			—			—	—	—
(D)		○			—			—	—	—

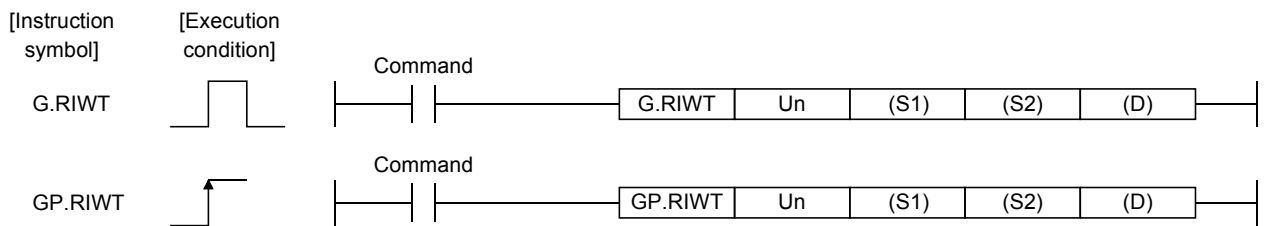

Set data

Device *1	Description	Setting range	Data type
Un	Start I/O number of the module (First 2 digits of I/O No. with three digits)	0 to FE <sub>H</sub>	Binary 16 bits
(S1)	Start number of the device in which control data is stored.	Within the range of the specified device	Device name
(S2)	Start number of the device to which write data is to be stored.	Within the range of the specified device	
(D)	Device that is turned ON for one scan upon completion of writing. (D) + 1 also turns ON at an abnormal completion.	Within the range of the specified device	Bit

\*1 The file register of each of the local device and the program cannot be used as a device for setting data.

Control data

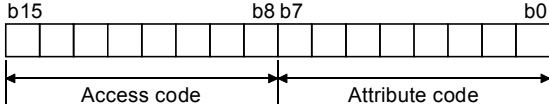
Device	Item	Set data	Setting range	Set by
(S1) + 0	Completion status	Stores the status when the instruction is complete. 0: No error (normal completion) Other than 0: Error code	—	System
(S1) + 1	Station number	Specify the station numbers of the master station, local station and intelligent device station.	0 to 64	User
(S1) + 2	Access code Attribute code		Page 201, Section 9.1.3 (1), Page 201, Section 9.1.3 (2)	User
(S1) + 3	Buffer memory address or device number	Specify the buffer memory start address or device start number.	*1	User
(S1) + 4	Number of points to write	Specify the write data count (in word units).	1 to 480* <sup>2</sup> 1 to 10* <sup>3</sup>	User

- \*1 For details, refer to the manual for the local station or the intelligent device station to which data are written. When the random access buffer is specified, specify the start address of the random access buffer as 0.
- \*2 The value indicates the maximum number of data to be written. Specify the value within the buffer memory capacity of the local station or the intelligent device station, or the send buffer area setting range set by a parameter.
- \*3 When writing device data to the programmable controller CPU other than the QCPU, LCPU, QnACPU or AnUCPU, the setting range shall be 1 to 10 words.

**(1) Buffer memory in the CC-Link**

Buffer Memory contents		Access code	Attribute code
Buffer in the intelligent device station		00 <sub>H</sub>	04 <sub>H</sub>
Buffers in master station and local station	Random access buffer	20 <sub>H</sub>	
	Remote input	21 <sub>H</sub>	
	Remote output	22 <sub>H</sub>	
	Remote register	24 <sub>H</sub>	
	Link special relay	63 <sub>H</sub>	
	Link special register	64 <sub>H</sub>	

**(2) Device memory in the programmable controller CPU**

Device contents	Name	Device type		Unit	Access code	Attribute code
		Bit	Word			
Input relay	X	○	—	Hexadecimal	01 <sub>H</sub>	05 <sub>H</sub>
Output relay	Y	○	—	Hexadecimal	02 <sub>H</sub>	
Internal relay	M	○	—	Decimal	03 <sub>H</sub>	
Latch relay	L	○	—	Decimal	83 <sub>H</sub>	
Link relay	B	○	—	Hexadecimal	23 <sub>H</sub>	
Timer (contact)	T	○	—	Decimal	09 <sub>H</sub>	
Timer (coil)	T	○	—	Decimal	0A <sub>H</sub>	
Timer (present value)	T	—	○	Decimal	0C <sub>H</sub>	
Retentive timer (contact)	ST	○	—	Decimal	89 <sub>H</sub>	
Retentive timer (coil)	ST	○	—	Decimal	8A <sub>H</sub>	
Retentive timer (present value)	ST	—	○	Decimal	8C <sub>H</sub>	
Counter (contact)	C	○	—	Decimal	11 <sub>H</sub>	
Counter (coil)	C	○	—	Decimal	12 <sub>H</sub>	
Counter (present value)	C	—	○	Decimal	14 <sub>H</sub>	
Data register	D	—	○	Decimal	04 <sub>H</sub>	
Link register	W	—	○	Hexadecimal	24 <sub>H</sub>	
File register	R	—	○	Decimal	84 <sub>H</sub>	
Link special relay	SB	○	—	Hexadecimal	63 <sub>H</sub>	
Link special register	SW	—	○	Hexadecimal	64 <sub>H</sub>	
Special relay	SM	○	—	Decimal	43 <sub>H</sub>	
Special register	SD	—	○	Decimal	44 <sub>H</sub>	

Devices other than shown above cannot be accessed.

When accessing a bit device, specify it with 0 or a multiple of 16.

The extended data register of address D65536 or higher, and the extended link register of address W10000 or higher cannot be specified.

### (3) Functions

#### (a) Operation chart for the G(P).RIWT instruction

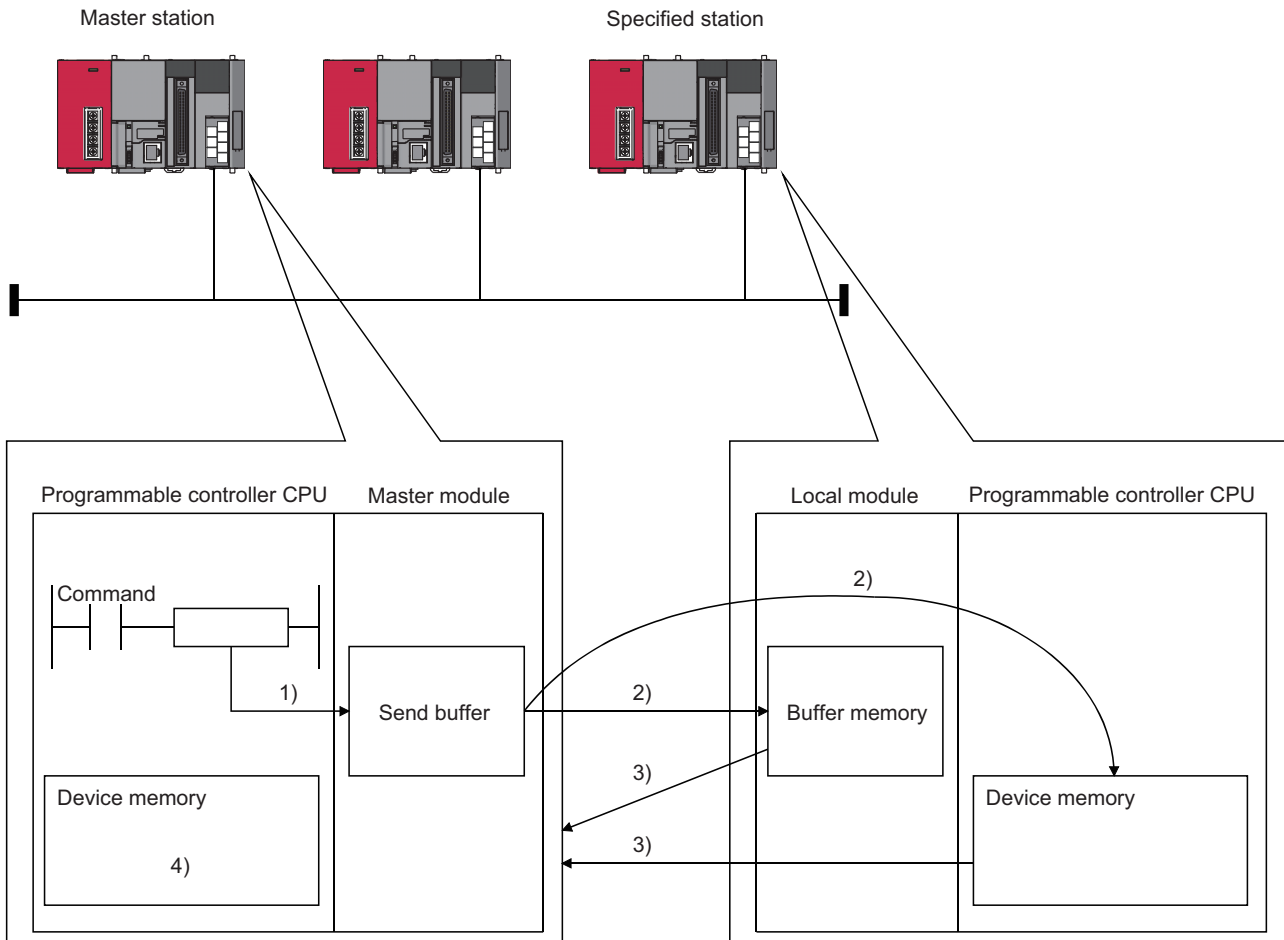

1. Stores the data to be written to the specified station in the send buffer of the master module.
2. Writes the data specified by (S2) to the buffer memory specified by (S1)+2 and (S1)+3 of the station specified by (S1)+1 or to the programmable controller CPU device.
3. The specified station returns the write complete response to the master station.
4. The device specified by (D) turns ON.

#### (b) The G(P).RIWT instruction can be executed to multiple local stations or intelligent device stations simultaneously.

Note that concurrent execution of multiple instructions including other dedicated instruction(s) (refer to  Page 191, Section 9.1) is not allowed to the same local station or intelligent device station.

Create a program in which a flag remains on until the instruction is completed.



**(c) There are two types of interlock signals for the G(P).RIWT instruction: the completion device (D) and the status display device at completion (D) + 1.**

1) Completion device

Turns ON in the END processing of the scan where the G(P).RIWT instruction is completed, and turns OFF in the next END processing.

2) Status display device at completion

Turns ON and OFF depending on the completion status of the G(P).RIWT instruction.

Normal completion: Stays OFF and does not change.

Abnormal completion: Turns ON in the END processing of the scan where the G(P).RIWT instruction is completed, and turns OFF in the next END processing.

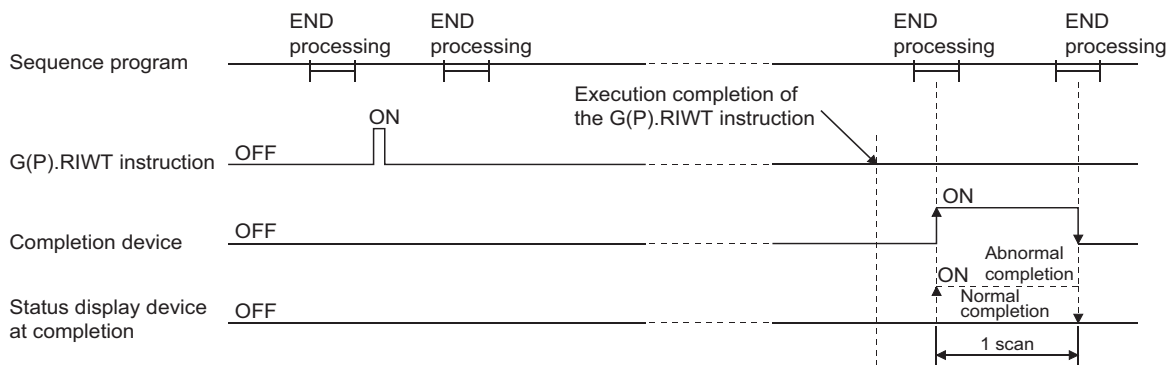

**(d) Multiple dedicated instructions cannot be executed for the same station.**

Since it takes several scans until the processing of the dedicated instruction is completed, execute the next dedicated instruction after the completion device has turned ON.

The next dedicated instruction executed before completion of the previously executed dedicated instruction is ignored.

**(e) The basic number of steps of the G(P).RIWT instruction is 8 steps.**

**(f) Use GX Works2 to assign send buffer in "Station Information Setting" in the "Network Parameter" window.**

For more details on the setting, refer to  Page 83, Section 7.3.2 (2).

**(4) Operation error**

In the following cases, an operation error occurs; the error flag (SM0) turns ON and the error code is stored in SD0.

Error code	Description of operation error
2112	When the module specified by Un is not an intelligent function module.
	When the module specified by Un is not a special function module.
4002	When an attempt was made to execute an unsupported instruction.
4003	When the number of devices in the instruction is incorrect.
4004	When the instruction specifies a device that cannot be used.
4100	When the instruction contains the data that cannot be used.
4101	When the number of data set to be used exceeds the allowable range.
	Or, when the storage data or constants of the device specified with the instruction exceeds the allowable range.

## (5) Program example

When X0 is turned ON, 10-word data are written from the area starting D0 in a local station (station No.1), which is connected to the master module in the I/O No. position of X/Y40 to X/Y5F, into the area starting from D1000. (When the link special register (SW) refresh device is set to SW0000) M13 is the G(P).RIWT instruction executing flag.

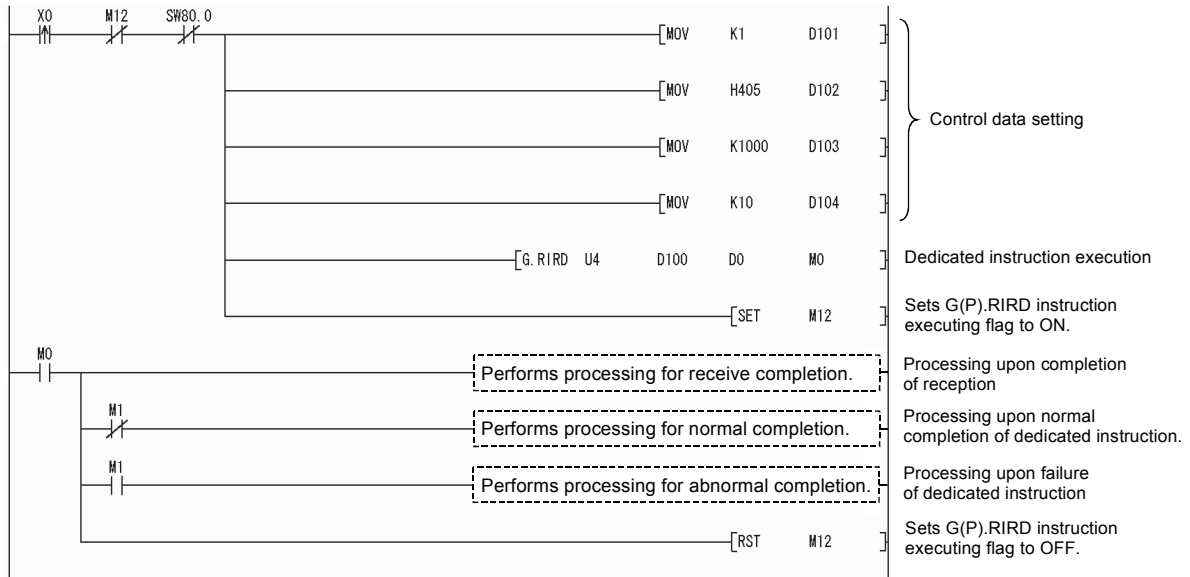

## 9.1.4 G(P).RIRCV

The G(P).RIRCV instruction automatically performs handshaking with an intelligent device station and reads data from the buffer memory of the specified intelligent device station.

Available for modules that have signals for the handshake (e.g. AJ65BT-R2N).

Set data	Usable devices									
	Internal device (System, user)		File register	Link direct device J□\□		Intelligent function module device U□\G□	Index register Z□	Constant		Other
	Bit	Word		Bit	Word			K, H	\$	
(S1)	—	○			—			—	—	—
(D1)	—	○			—			—	—	—
(S2)	—	○			—			—	—	—
(D2)		○			—			—	—	—

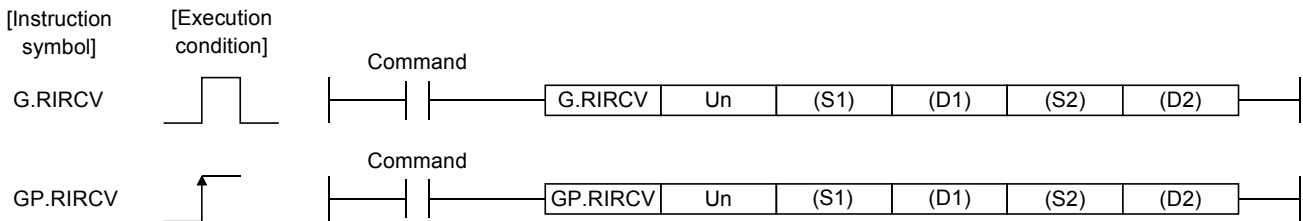

Set data

Device *1	Description	Setting range	Data type
Un	Start I/O number of the module (First 2 digits of I/O No. with three digits)	0 to FE <sub>H</sub>	Binary 16 bits
(S1)	Start number of the device in which control data is stored.	Within the range of the specified device	Device name
(D1)	Start number of the device to which read data is to be stored.	Within the range of the specified device	
(S2)	Start number of the device in which the interlock signals are stored.	Within the range of the specified device	
(D2)	Device that is turned ON for one scan upon completion of reading. (D2)+1 also turns ON at an abnormal completion.	Within the range of the specified device	Bit

\*1 The file register of each of the local device and the program cannot be used as a device for setting data.

Control data

Device	Item	Set data	Setting range	Set by
(S1) + 0	Completion status	Stores the status when the instruction is complete. 0: No error (normal completion) Other than 0: Error code	—	System
(S1) + 1	Station number	Specify the station number of the intelligent device station.	0 to 64	User
(S1) + 2	Access code Attribute code	Set "0004 <sub>H</sub> ".	0004 <sub>H</sub>	User
(S1) + 3	Buffer memory address	Specify the buffer memory start address.	*1	User
(S1) + 4	Number of points to read	Specify the read data count (in word units).	1 to 480* <sup>2</sup>	User

\*1 Refer to the manual for the intelligent device station from which data will be read.

\*2 Indicates the maximum number of data items that can be read.

Specify the buffer memory capacities of the intelligent device station and the receive buffer area setting range to be set with a parameter.

Interlock signal storage devices

Device	Item	Set data	Setting range	Set by				
(S2) + 0	<table border="1" style="display: inline-table; vertical-align: middle;"> <tr> <td>b15 to b8</td> <td>b7 to b0</td> </tr> <tr> <td>0</td> <td>RY</td> </tr> </table>	b15 to b8	b7 to b0	0	RY	RY: Request device	0 to 127	User
		b15 to b8	b7 to b0					
0	RY							
		Set the upper 8 bits to 0.	0	User				
(S2) + 1	<table border="1" style="display: inline-table; vertical-align: middle;"> <tr> <td>b15 to b8</td> <td>b7 to b0</td> </tr> <tr> <td>RWr *1</td> <td>RX</td> </tr> </table>	b15 to b8	b7 to b0	RWr *1	RX	RX: Completion device	0 to 127	User
		b15 to b8	b7 to b0					
RWr *1	RX							
		RWr: Error code storage device If none, set to FF <sub>H</sub> .	0 to 15 FF <sub>H</sub>	User				
(S2) + 2	<table border="1" style="display: inline-table; vertical-align: middle;"> <tr> <td>b15 to b0</td> </tr> <tr> <td>completion mode</td> </tr> </table>	b15 to b0	completion mode	0: Complete with the contents of 1 device (RXn). 1: Complete with the contents of 2 devices (RXn and RXn+1). (RXn+1 turns ON at an abnormal completion.)	0/1	User		
b15 to b0								
completion mode								

\*1 The same error code as that for the control data completion status is stored in the error code storage device.

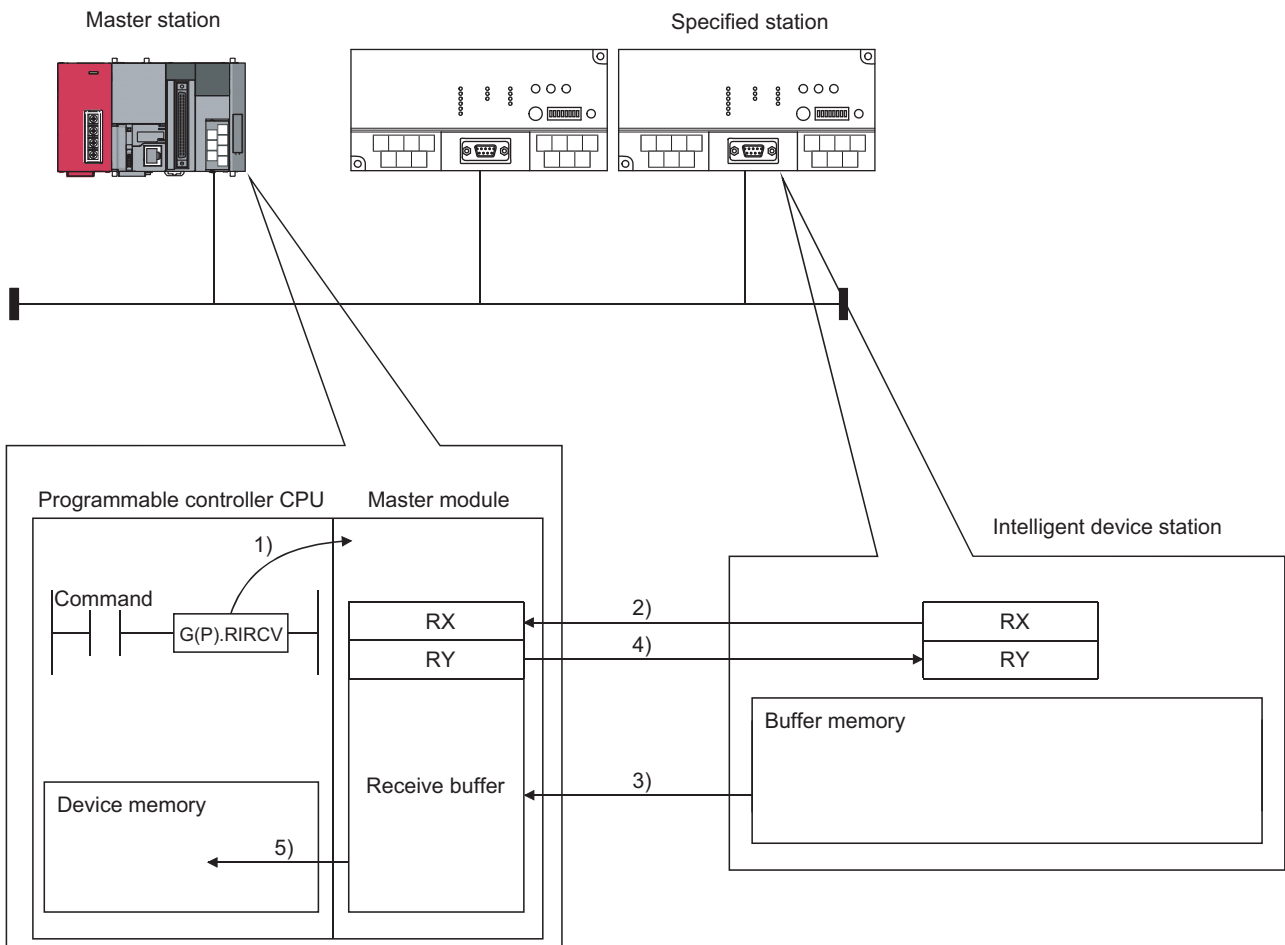
**(1) Functions****(a) Operation chart for the G(P).RIRCV instruction**

- 1) Instructs the master module to read data from the buffer memory specified in (S1)+2 and (S1)+3 of the station specified in (S1)+1.
- 2) The master module monitors the remote input (RX) specified in (S2)+1.
- 3) When the remote input (RX) specified in (S2)+1 turns ON from OFF, the master module reads data from the buffer memory of the specified station.  
Read data are stored in the receive buffer of the master module.
- 4) The master module turns the remote output (RY) specified in (S2)+0 ON.  
When the remote input specified in (S)+1 turns OFF from ON, the remote output specified in (S2)+0 turns OFF.
- 5) Data read out from the specified station are stored in the device specified in (D1) and subsequent devices, and a device specified in D2 turns ON.

**(b) The G(P).RIRCV instruction can be executed to multiple intelligent device stations simultaneously.**

Note that concurrent execution of multiple instructions including other dedicated instruction(s) (refer to  Page 191, Section 9.1) is not allowed to the same local station or intelligent device station.  
Create a program in which a flag remains on until the instruction is completed.

**(c) There are two types of interlock signals for the G(P).RIRCV instruction: the completion device (D2) and the status display device at completion (D2)+1.**

- Completion device  
Turns ON in the END processing of the scan where the G(P).RIRCV instruction is completed, and turns OFF in the next END processing.
- Status display device at completion  
Turns ON and OFF depending on the completion status of the G(P).RIRCV instruction.  
Normal completion: Stays OFF and does not change.  
Abnormal completion: Turns ON in the END processing of the scan where the G(P).RIRCV instruction is completed, and turns OFF in the next END processing.

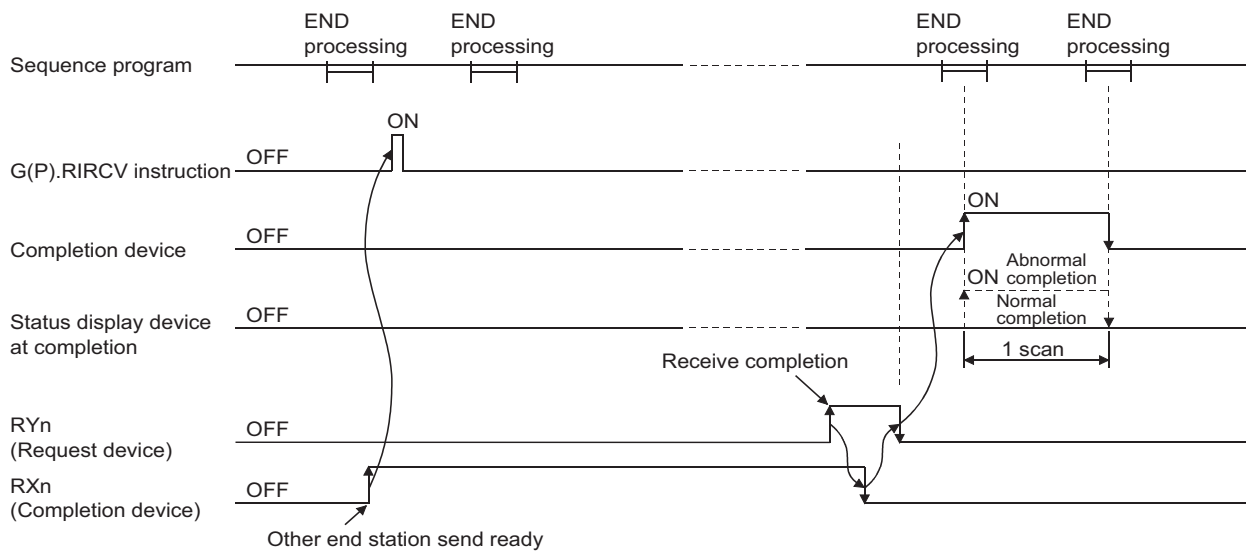

**(d) Multiple dedicated instructions cannot be executed for the same station.**

Since it takes several scans until the processing of the dedicated instruction is completed, execute the next dedicated instruction after the completion device has turned ON. The next dedicated instruction executed before completion of the previously executed dedicated instruction is ignored.

**(e) The basic number of steps of the G(P).RIRCV instruction is 10 steps.**

**(f) Use GX Works2 to assign receive buffer in "Station Information Setting" in the "Network Parameter" window.**

For more details on the setting, refer to  Page 83, Section 7.3.2 (2).

**(2) Operation error**

In the following cases, an operation error occurs; the error flag (SM0) turns ON and the error code is stored in SD0.

Error code	Description of operation error
2112	When the module specified by Un is not an intelligent function module.
	When the module specified by Un is not a special function module.
4002	When an attempt was made to execute an unsupported instruction.
4003	When the number of devices in the instruction is incorrect.
4004	When the instruction specifies a device that cannot be used.
4100	When the instruction contains the data that cannot be used.
4101	When the number of data set to be used exceeds the allowable range.
	Or, when the storage data or constants of the device specified with the instruction exceeds the allowable range.

**(3) Program example**

When M1 turns ON, 11-word data in the buffer memory address 400<sub>H</sub> and later of the intelligent device station No.63 (AJ65BT-R2N), which is connected to the master module installed in the position of I/O No. X/Y00 to X/Y1F, are read out to the area starting from D40.

The settings of the interlock signal storage device are as follows: request device RY2, completion device RX2, error code storage device RWr2, and completion mode 1.

Also, set the link special register (SW) refresh device to SW0000.

M10 is the G(P).RIRCV instruction executing flag.

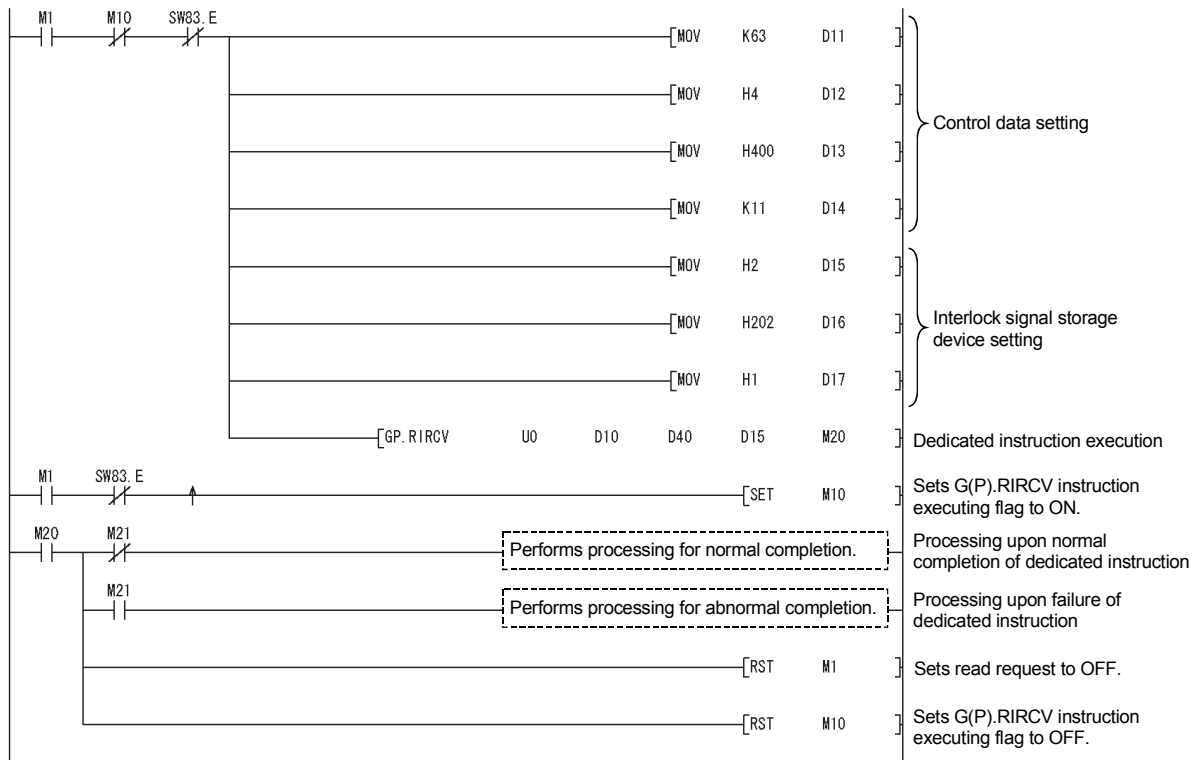

## 9.1.5 G(P).RISEND

The G(P).RISEND instruction automatically performs handshaking with an intelligent device station and writes data to the buffer memory of the specified intelligent device station.

Available for modules that have signals for the handshake (e.g. AJ65BT-R2N).

Set data	Usable devices									
	Internal device (System, user)		File register	Link direct device J□\□		Intelligent function module device U□\G□	Index register Z□	Constant		Other
	Bit	Word		Bit	Word			K, H	\$	
(S1)	—	○			—			—	—	—
(S2)	—	○			—			—	—	—
(S3)	—	○			—			—	—	—
(D)		○			—			—	—	—

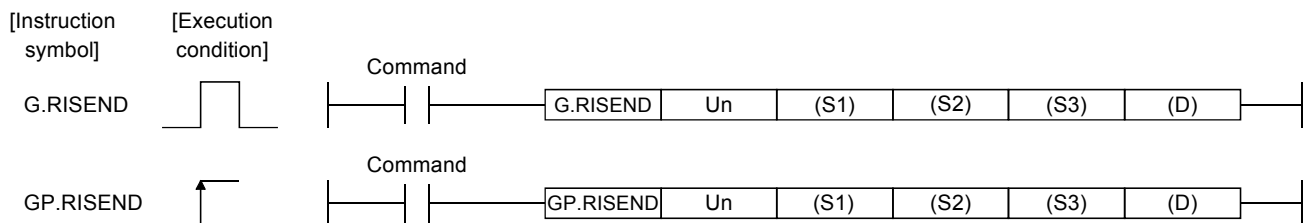

Set data

Device <sup>*1</sup>	Description	Setting range	Data type
Un	Start I/O number of the module (First 2 digits of I/O No. with three digits)	0 to FE <sub>H</sub>	Binary 16 bits
(S1)	Start number of the device in which control data is stored.	Within the range of the specified device	Device name
(S2)	Start number of the device to which write data is to be stored.	Within the range of the specified device	
(S3)	Start number of the device in which the interlock signals are stored.	Within the range of the specified device	
(D)	Device that is turned ON for one scan upon completion of writing. (D)+1 also turns ON at an abnormal completion.	Within the range of the specified device	Bit

\*1 The file register of each of the local device and the program cannot be used as a device for setting data.



## Control data

Device	Item	Set data	Setting range	Set by
(S1) + 0	Completion status	Stores the status when the instruction is complete. 0: No error (normal completion) Other than 0: Error code	—	System
(S1) + 1	Station number	Specify the station number of the intelligent device station.	0 to 64	User
(S1) + 2	Access code Attribute code	Set "0004 <sub>H</sub> ".	0004 <sub>H</sub>	User
(S1) + 3	Buffer memory address	Specify the buffer memory start address.	*1	User
(S1) + 4	Number of points write	Specify the write data count (in word units).	1 to 480*2	User

\*1 Refer to the manual for the intelligent device station to which data will be written.

\*2 Indicates the maximum number of data items that can be written.  
Specify the buffer memory capacities of the intelligent device station and the receive buffer area setting range to be set with a parameter.

## Interlock signal storage devices

Device	Item	Set data	Setting range	Set by						
(S3) + 0	<table border="1"> <tr> <td>b15 to b8</td> <td>b7 to b0</td> </tr> <tr> <td>0</td> <td>RY</td> </tr> </table>	b15 to b8	b7 to b0	0	RY	RY: Request device	0 to 127	User		
		b15 to b8	b7 to b0							
0	RY									
Set the upper 8 bits to 0.	0	User								
(S3) + 1	<table border="1"> <tr> <td>b15 to b8</td> <td>b7 to b0</td> </tr> <tr> <td>RWr*1</td> <td>RX</td> </tr> </table>	b15 to b8	b7 to b0	RWr*1	RX	RX: Completion device	0 to 127	User		
		b15 to b8	b7 to b0							
RWr*1	RX									
RWr: Error code storage device If none, set to FF <sub>H</sub> .	0 to 15 FF <sub>H</sub>	User								
(S3) + 2	<table border="1"> <tr> <td>b15</td> <td>to</td> <td>b0</td> </tr> <tr> <td colspan="3">Completion mode</td> </tr> </table>	b15	to	b0	Completion mode			0: Complete with the contents of 1 device (RXn). 1: Complete with the contents of 2 devices (RXn and RXn+1). (RXn+1 turns ON at an abnormal completion.)	0/1	User
b15	to	b0								
Completion mode										

\*1 The same error code as that for the control data completion status is stored in the error code storage device.

## (1) Functions

### (a) Operation chart for the G(P).RISEND instruction

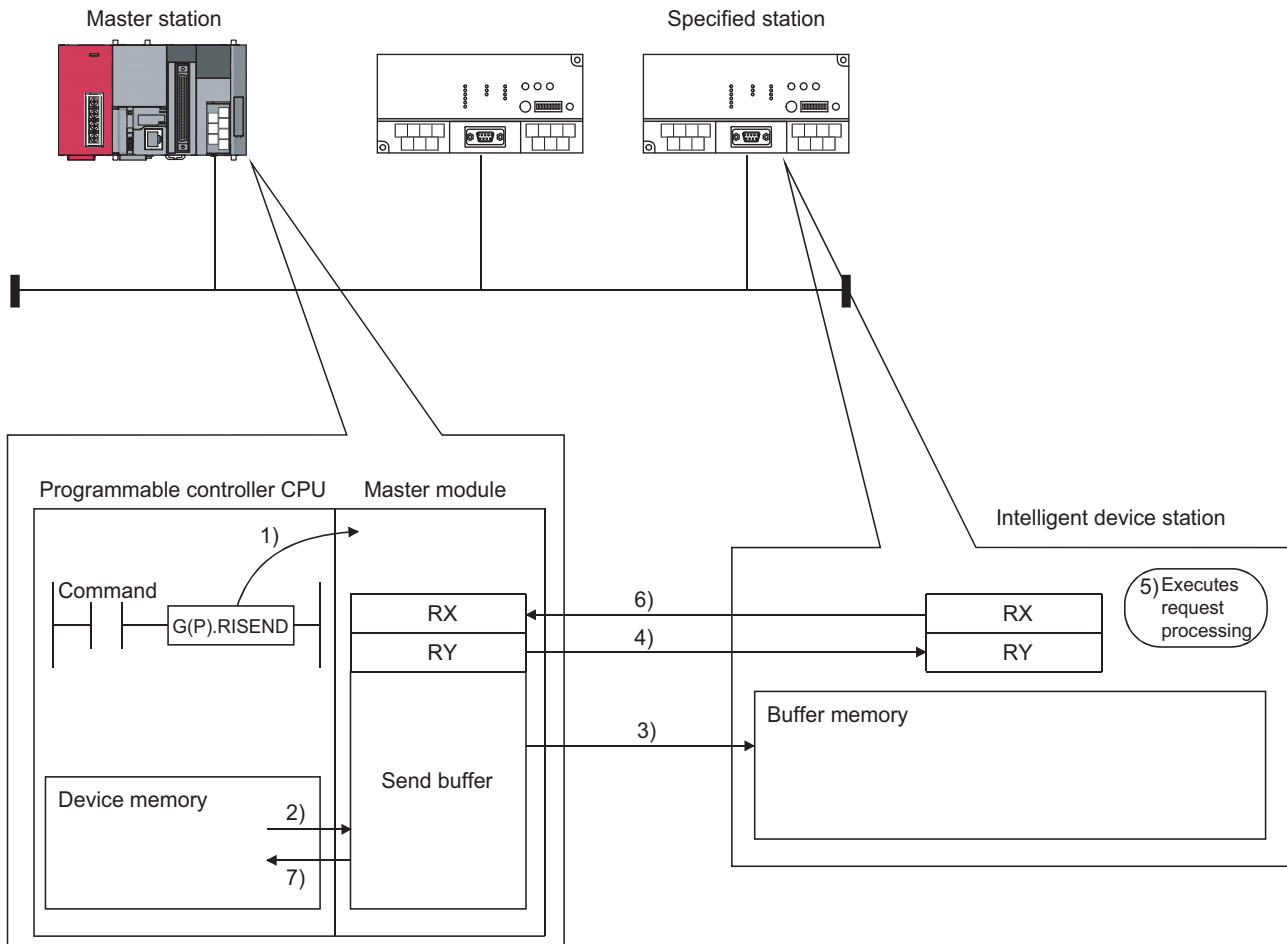

- 1) Instructs the master module to write data to the buffer memory specified in (S1)+2 and (S1)+3 of the station specified in (S1)+1.
- 2) Data to be written to the specified station are stored in the send buffer of the master module.
- 3) Data are written to the buffer memory specified in (S1)+2 and (S1)+3 of the station specified in (S1)+1.
- 4) The master module turns the remote output (RY) specified in (S3)+0 ON.
- 5) The station specified in (S1)+1 performs processing for the remote output (RY).
- 6) Upon completion of the processing for the remote output (RY), the station specified in (S1)+1 turns the remote input (RX) specified in (S3)+1 ON and the remote output (RY) specified in (S3)+0 turns OFF. Also, the response showing completion of write to the master module is returned.
- 7) The device specified in (D) turns ON.

### (b) The G(P).RISEND instruction can be executed to multiple intelligent device stations simultaneously.

Note that concurrent execution of multiple instructions including other dedicated instruction(s) (refer to  Page 191, Section 9.1) is not allowed to the same local station or intelligent device station. Create a program in which a flag remains on until the instruction is completed.

**(c) There are two types of interlock signals for the G(P).RISEND instruction: the completion device (D) and the status display device at completion (D)+1.**

- Completion device  
Turns ON in the END processing of the scan where the G(P).RISEND instruction is completed, and turns OFF in the next END processing.
- Status display device at completion  
Turns ON and OFF depending on the completion status of the G(P).RISEND instruction.  
Normal completion: Stays OFF and does not change.  
Abnormal completion: Turns ON in the END processing of the scan where the G(P).RISEND instruction is completed, and turns OFF in the next END processing.

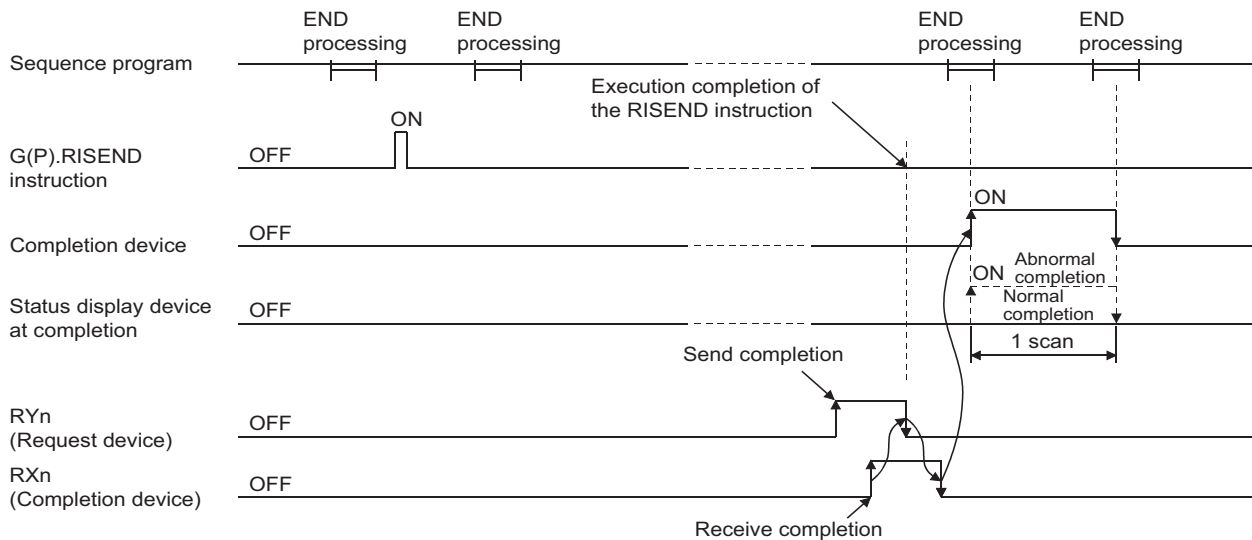

**(d) Multiple dedicated instructions cannot be executed for the same station.**

Since it takes several scans until the processing of the dedicated instruction is completed, execute the next dedicated instruction after the completion device has turned ON.

The next dedicated instruction executed before completion of the previously executed dedicated instruction is ignored.

**(e) The basic number of steps of the G(P).RISEND instruction is 10 steps.**

**(f) Use GX Works2 to assign send buffer in "Station Information Setting" in the "Network Parameter" window.**

For more details on the setting, refer to  Page 83, Section 7.3.2 (2).

## (2) Operation error

In the following cases, operation error occurs; the error flag (SM0) turns ON and the error code is stored in SD0.

Error code	Description of operation error
2112	When the module specified by Un is not an intelligent function module.
	When the module specified by Un is not a special function module.
4002	When an attempt was made to execute an unsupported instruction.
4003	When the number of devices in the instruction is incorrect.
4004	When the instruction specifies a device that cannot be used.
4100	When the instruction contains the data that cannot be used.
4101	When the number of data set to be used exceeds the allowable range.
	Or, when the storage data or constants of the device specified with the instruction exceeds the allowable range.

## (3) Program example

When M6 is turned ON, 1-word data are written from the area starting D0 into the buffer memory address 111<sub>H</sub> of the intelligent device station No.63 (AJ65BT-R2N), which is connected to the master module installed in the position of I/O No. X/Y00 to X/Y1F.

The settings of the interlock signal storage device are as follows: request device RY4, completion device RX4, error code storage device RWr1, and completion mode 1.

Also, set the link special register (SW) refresh device to SW0000.

M11 is the G(P).RISEND instruction executing flag.

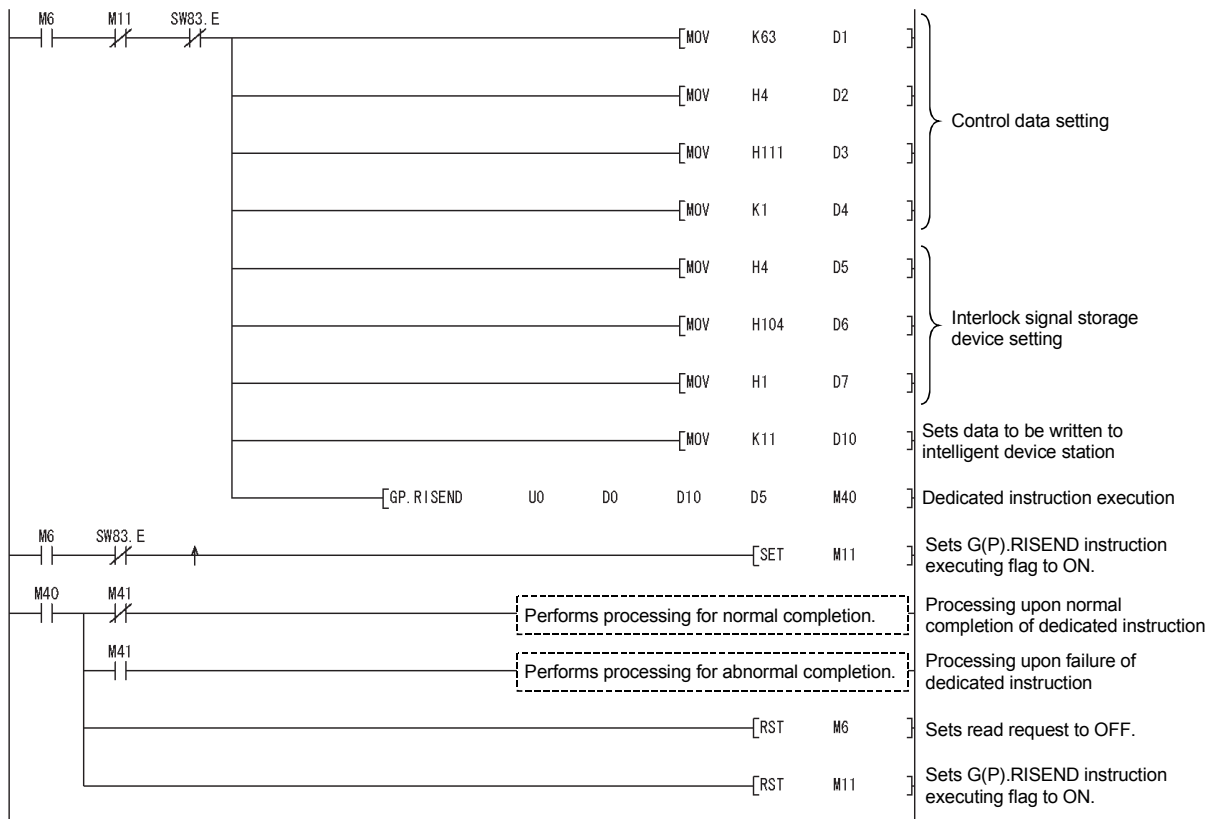

## 9.1.6 G(P).RIFR

The G(P).RIFR instruction reads the data from the automatic update buffer of the specified station.  
Available for modules that have the automatic update buffer (e.g. AJ65BT-R2N).

Set data	Usable devices									
	Internal device (System, user)		File register	Link direct device J□□		Intelligent function module device U□\G□	Index register Z□	Constant		Other
	Bit	Word		Bit	Word			K, H	\$	
n1	○	○			—		○	—	—	
n2	○	○			—		○	—	—	
(D)	—	○			—		—	—	—	
n3	○	○			—		○	—	—	

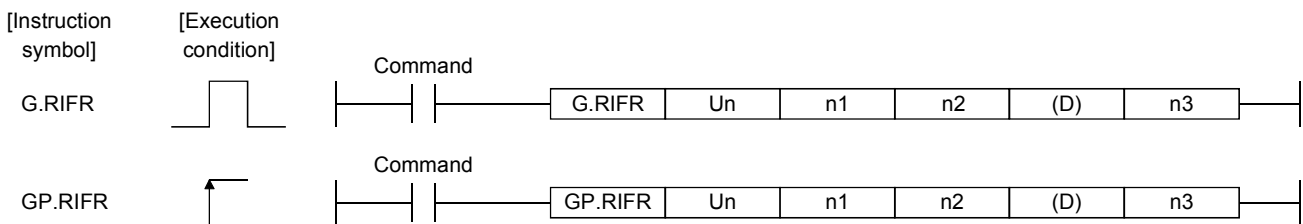

Set data

Device	Description	Setting range	Data type
Un	Start I/O number of the module (First 2 digits of I/O No. with three digits)	0 to FE <sub>H</sub>	Binary 16 bits
n1	Intelligent device station number	1 to 64	
	Random access buffer specification	FF <sub>H</sub>	
n2	The offset value of the automatic update buffer of the intelligent device station specified by the master station or the random access buffer.	Between 0 and parameter setting value <sup>*1</sup>	
(D)	Start number of the device to which read data is to be stored.	Within the range of the specified device	Device
n3	Number of points to read	0 to 4096 <sup>*2</sup>	Binary 16 bits

\*1 The value set in the "Station Information Setting" of the network parameters of the GX Works2.

\*2 No processing will be performed when set to "0".

## (1) Functions

### (a) Operation chart for the G(P).RIFR instruction

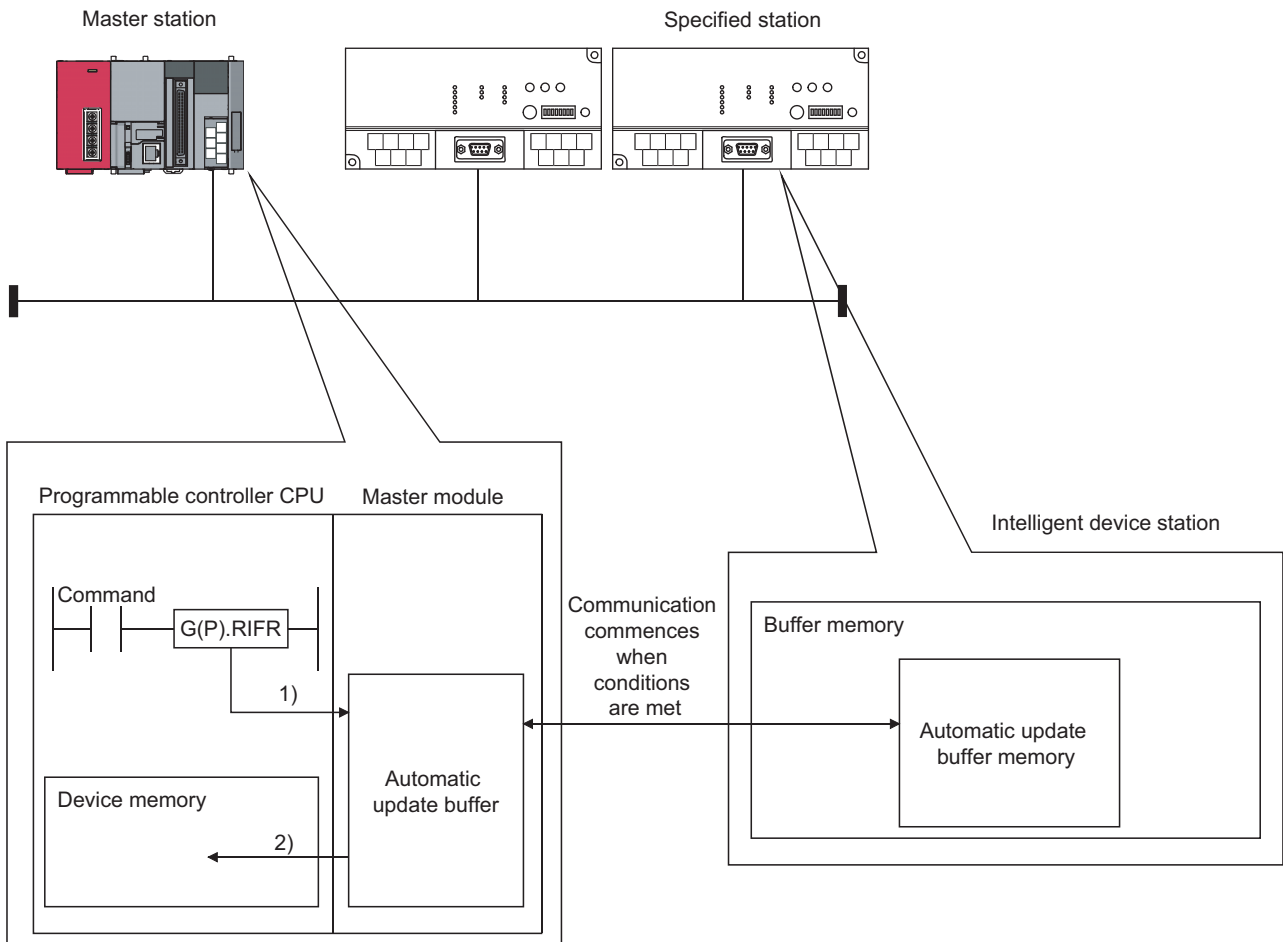

- 1) Accesses the automatic update buffer specified by n1 and n2 of the master module specified by Un.
- 2) Stores the data read after the device specified by (D).

### (b) The G(P).RIFR instruction reads data when it is executed.

However, this instruction cannot be executed simultaneously at more than one location for the same intelligent device station.

### (c) The maximum points that can be read by the G(P).RIFR instruction are 4096.

### (d) The basic number of steps of the G(P).RIFR instruction is 9 steps.

### (e) Use GX Works2 to assign automatic update buffer in "Station Information Setting" in the "Network Parameter" window.

For more details on the setting, refer to  Page 83, Section 7.3.2 (2).

**(2) Operation error**

In the following cases, operation error occurs; the error flag (SM0) turns ON and the error code is stored in SD0.

Error code	Description of operation error
2112	When the module specified by Un is not an intelligent function module.
	When the module specified by Un is not a special function module.
4002	When an attempt was made to execute an unsupported instruction.
4003	When the number of devices in the instruction is incorrect.
4004	When the instruction specifies a device that cannot be used.
4100	When the setting for number of points to read (n3) is outside of the setting range.
	When the station number specified with n1 does not exist.

**(3) Program example**

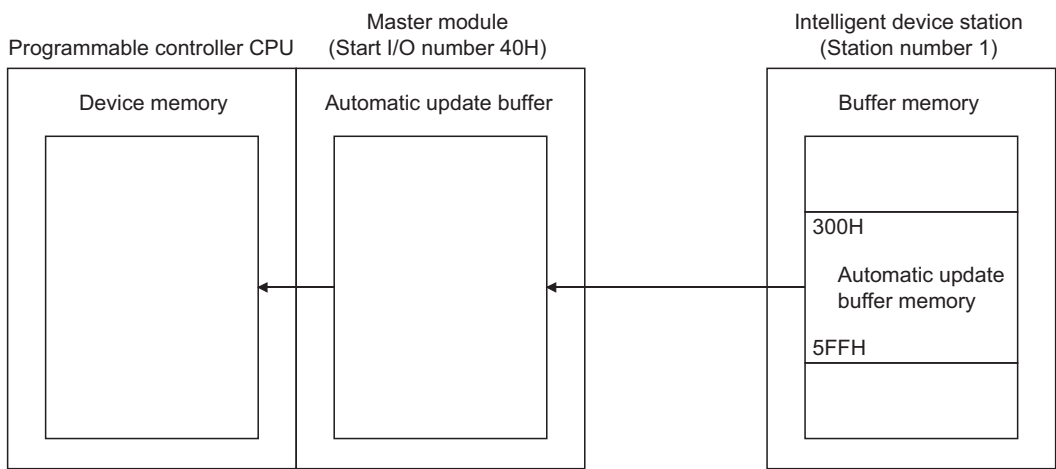

When X0 is turned ON, the following example program reads 10-word data to D0 or succeeding addresses from the automatic update buffer offset value of 100 (400<sub>H</sub> of the intelligent device station) in the master module.

(When the link special register (SW) refresh device is set to SW0000)



## 9.1.7 G(P).RITO

The G(P).RITO instruction writes data to the automatic update buffer of the specified station.  
Available for modules that have the automatic update buffer (e.g. AJ65BT-R2N).

Set data	Usable devices									
	Internal device (System, user)		File register	Link direct device J□\□		Intelligent function module device U□\G□	Index register Z□	Constant		Other
	Bit	Word		Bit	Word			K, H	\$	
n1	○	○				—		○	—	—
n2	○	○				—		○	—	—
(D)	—	○				—		—	—	—
n3	○	○				—		○	—	—

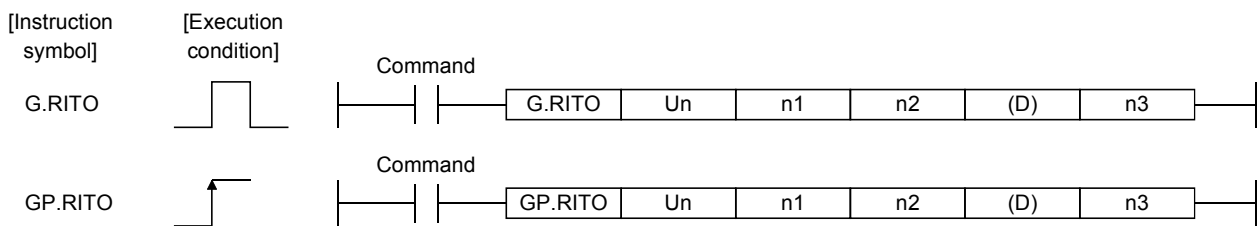

Set data

Device	Description	Setting range	Data type
Un	Start I/O number of the module (First 2 digits of I/O No. with three digits)	0 to FE <sub>H</sub>	Binary 16 bits
n1	Intelligent device station number	1 to 64	
	Random access buffer specification	FF <sub>H</sub>	
n2	The offset value of the automatic update buffer of the intelligent device station specified by the master station or the random access buffer.	Between 0 and parameter setting value <sup>*1</sup>	
(D)	Start number of the device to which write data is to be stored.	Within the range of the specified device	Device
n3	Number of points to write	0 to 4096 <sup>*2</sup>	Binary 16 bits

\*1 The value set in the "Station Information Setting" of the network parameters of the GX Works2.

\*2 No processing will be performed when set to "0".

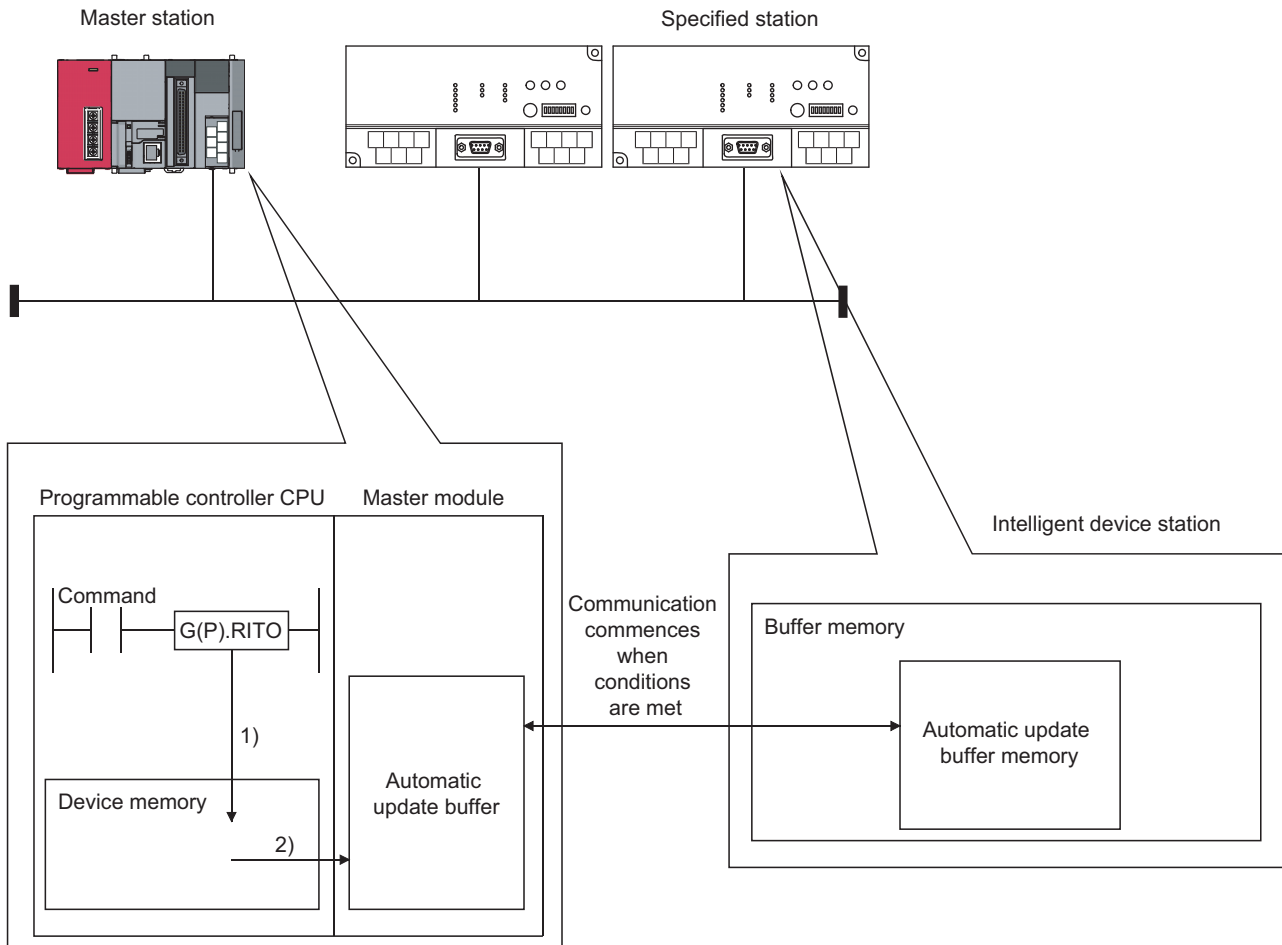

**(1) Functions****(a) Operation chart for the G(P).RITO instruction**

- 1) Accesses the device after the device specified by (D) of the master module specified by Un.
- 2) Writes to the automatic update buffer specified by n1 and n2.

**(b) The G(P).RITO instruction writes data when it is executed.**

However, this instruction cannot be executed simultaneously at more than one location for the same intelligent device station.

**(c) The maximum points that can be read by the G(P).RITO instruction are 4096.****(d) The basic number of steps of the G(P).RITO instruction is 9 steps.****(e) Use GX Works2 to assign automatic update buffer in "Station Information Setting" in the "Network Parameter" window.**

For more details on the setting, refer to  Page 83, Section 7.3.2 (2).

## (2) Operation error

In the following cases, operation error occurs; the error flag (SM0) turns ON and the error code is stored in SD0.

Error code	Description of operation error
2112	When the module specified by Un is not an intelligent function module.
	When the module specified by Un is not a special function module.
4002	When an attempt was made to execute an unsupported instruction.
4003	When the number of devices in the instruction is incorrect.
4004	When the instruction specifies a device that cannot be used.
4100	When the setting for number of points to write (n3) is outside of the setting range.
	When the station number specified with n1 does not exist.

## (3) Program example

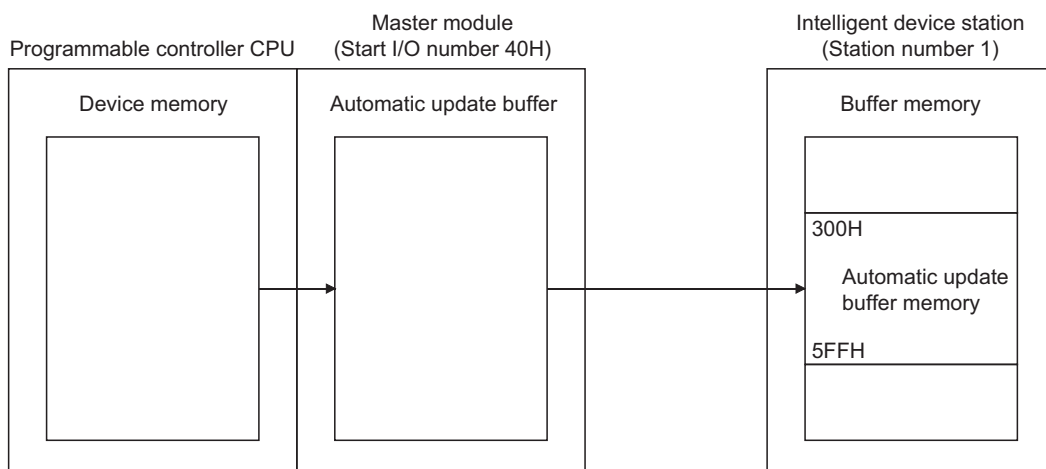

When X0 is turned ON, the following example program writes 10-word data from D0 to the automatic update buffer offset value starting from 100 (400<sub>H</sub> of the intelligent device station) in the master module.

(When the link special register (SW) refresh device is set to SW0000)



## 9.1.8 G(P).RLPASET

The G(P).RLPASET instruction sets network parameters to the master station and starts the data link.

Set data	Usable devices									
	Internal device (System, user)		File register	Link direct device J□\□		Intelligent function module device U□\G□	Index register Z□	Constant		Other
	Bit	Word		Bit	Word			K, H	\$	
(S1)	—	○						—	—	—
(S2)	—	○						—	—	—
(S3)	—	○						—	—	—
(S4)	—	○						—	—	—
(S5)	—	○						—	—	—
(D)		○						—	—	—

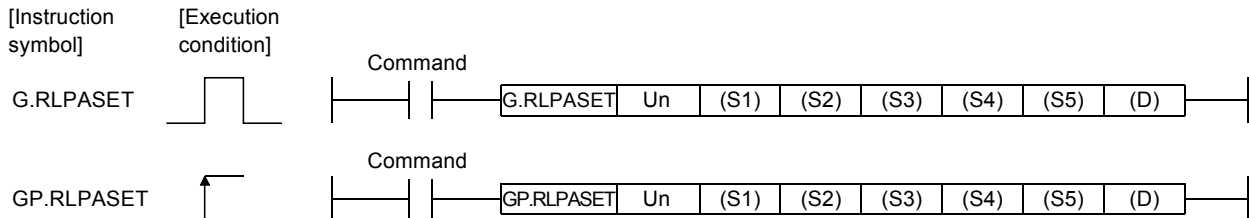

Master station set data

Device <sup>*1</sup>	Description	Setting range	Data type
Un	Start I/O number of the module (First 2 digits of I/O No. with three digits)	0 to FE <sub>H</sub>	Binary 16 bits
(S1)	Start number of the device in which control data is stored.	Within the range of the specified device	Device name
(S2) <sup>*2</sup>	Start number of the device in which slave station setting data is stored.	Within the range of the specified device	
(S3) <sup>*2</sup>	Start number of the device in which reserved station specification data is stored.	Within the range of the specified device	
(S4) <sup>*2</sup>	Start number of the device in which error invalid station specification data is stored.	Within the range of the specified device	
(S5) <sup>*2</sup>	Start number of the device in which send, receive and automatic refresh buffer assignment data is stored.	Within the range of the specified device	
(D)	Device that is turned ON for one scan upon completion of reading. (D)+1 also turns ON at an abnormal completion.	Within the range of the specified device	Bit

\*1 The file register of each of the local device and the program cannot be used as a device for setting data.

\*2 When the setting data for (S2) to (S5) are not to be set, specify a dummy device.

Control data

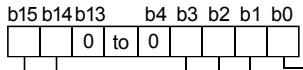
Device	Item	Set data	Setting range *2	Set by
(S1) + 0	Completion status	Stores the status when the instruction is complete. 0: No error (normal completion) Other than 0: Error code	—	System
(S1) + 1	Setting flag	Specifies whether the individual setting data from (S2) to (S5) is valid or invalid. 0: Invalid*1 1: Valid   <p>Mode 00: Remote net (Ver.1 mode) 01: Remote net (Additional mode) 10: Remote net (Ver.2 mode) 11: Not used</p>	—	User
(S1) + 2	Number of connected modules involved in communication	Sets the number of connected slave stations.	1 to 64	
(S1) + 3	Number of retries	Sets the number of retries to a communication faulty station.	1 to 7	
(S1) + 4	Number of automatic return modules	Sets the number of slave stations that can be returned per one link scan.	1 to 10	
(S1) + 5	Operation specification when CPU is down	Specifies the data link status when a master station programmable controller CPU error occurs. 0: Stop 1: Continue	0, 1	
(S1) + 6	Scan mode specification	Specifies either the synchronous or asynchronous mode for sequence scan. 0: Asynchronous 1: Synchronous	0, 1	
(S1) + 7	Delay time setting	Set 0 for the delay time.	0	

\*1 For the setting data specified invalid, default parameter will be applied.

\*2 Setting a value outside the setting range results in abnormal completion.

Slave station setting data

Device	Item	Set data	Setting range	Set by																								
(S2) + 0 ⋮ (S2) + 63	Setting for 1 to 64 modules <sup>*3</sup>	<p>The type of slave station, number of occupied slave stations and station number are set as follows.</p> <p>The default parameter settings are "0101<sub>H</sub> to 0140<sub>H</sub>" (station number: 1 to 64, number of occupied slave stations: 1, type of slave station: remote I/O station).</p>	—	User																								
		Setting of the station number 1 to 64 (BIN setting)	1 to 40 <sub>H</sub>																									
		Setting of the number of occupied slave stations	1 to 4 <sub>H</sub>																									
		<table border="1"> <thead> <tr> <th>Number of occupied slave stations</th> <th>Setting</th> </tr> </thead> <tbody> <tr> <td>Station 1</td> <td>1<sub>H</sub></td> </tr> <tr> <td>Station 2</td> <td>2<sub>H</sub></td> </tr> <tr> <td>Station 3</td> <td>3<sub>H</sub></td> </tr> <tr> <td>Station 4</td> <td>4<sub>H</sub></td> </tr> </tbody> </table>			Number of occupied slave stations	Setting	Station 1	1 <sub>H</sub>	Station 2	2 <sub>H</sub>	Station 3	3 <sub>H</sub>	Station 4	4 <sub>H</sub>														
		Number of occupied slave stations			Setting																							
		Station 1			1 <sub>H</sub>																							
		Station 2			2 <sub>H</sub>																							
		Station 3	3 <sub>H</sub>																									
		Station 4	4 <sub>H</sub>																									
		Setting of the type of slave station Ver.1 compatible remote device station <sup>*4</sup>	0 to F <sub>H</sub>																									
		<table border="1"> <thead> <tr> <th>Type of slave station</th> <th>Setting</th> </tr> </thead> <tbody> <tr> <td>Ver.1 compatible remote I/O station</td> <td>0<sub>H</sub></td> </tr> <tr> <td>Ver.1 compatible remote device station</td> <td>1<sub>H</sub></td> </tr> <tr> <td>Ver.1 compatible intelligent device station</td> <td>2<sub>H</sub></td> </tr> <tr> <td>Ver.2 compatible single remote device station</td> <td>5<sub>H</sub></td> </tr> <tr> <td>Ver.2 compatible single intelligent device station</td> <td>6<sub>H</sub></td> </tr> <tr> <td>Ver.2 compatible double remote device station</td> <td>8<sub>H</sub></td> </tr> <tr> <td>Ver.2 compatible double intelligent device station</td> <td>9<sub>H</sub></td> </tr> <tr> <td>Ver.2 compatible quadruple remote device station</td> <td>B<sub>H</sub></td> </tr> <tr> <td>Ver.2 compatible quadruple intelligent device station</td> <td>C<sub>H</sub></td> </tr> <tr> <td>Ver.2 compatible octuple remote device station</td> <td>E<sub>H</sub></td> </tr> <tr> <td>Ver.2 compatible octuple intelligent device station</td> <td>F<sub>H</sub></td> </tr> </tbody> </table>			Type of slave station	Setting	Ver.1 compatible remote I/O station	0 <sub>H</sub>	Ver.1 compatible remote device station	1 <sub>H</sub>	Ver.1 compatible intelligent device station	2 <sub>H</sub>	Ver.2 compatible single remote device station	5 <sub>H</sub>	Ver.2 compatible single intelligent device station	6 <sub>H</sub>	Ver.2 compatible double remote device station	8 <sub>H</sub>	Ver.2 compatible double intelligent device station	9 <sub>H</sub>	Ver.2 compatible quadruple remote device station	B <sub>H</sub>	Ver.2 compatible quadruple intelligent device station	C <sub>H</sub>	Ver.2 compatible octuple remote device station	E <sub>H</sub>	Ver.2 compatible octuple intelligent device station	F <sub>H</sub>
		Type of slave station			Setting																							
		Ver.1 compatible remote I/O station			0 <sub>H</sub>																							
Ver.1 compatible remote device station	1 <sub>H</sub>																											
Ver.1 compatible intelligent device station	2 <sub>H</sub>																											
Ver.2 compatible single remote device station	5 <sub>H</sub>																											
Ver.2 compatible single intelligent device station	6 <sub>H</sub>																											
Ver.2 compatible double remote device station	8 <sub>H</sub>																											
Ver.2 compatible double intelligent device station	9 <sub>H</sub>																											
Ver.2 compatible quadruple remote device station	B <sub>H</sub>																											
Ver.2 compatible quadruple intelligent device station	C <sub>H</sub>																											
Ver.2 compatible octuple remote device station	E <sub>H</sub>																											
Ver.2 compatible octuple intelligent device station	F <sub>H</sub>																											

\*3 Perform the settings for as many connected modules involved in communication as has been specified by the control data.

\*4 Setting a value outside the setting range in the slave station type setting results in abnormal completion.

Reserved station specification data

Device	Item	Set data	Setting range	Set by																																																		
(S3) + 0 ⋮ (S3) + 3	Setting for 1 to 64 modules <sup>*5</sup>	<p>Specify reserved stations.<sup>*6</sup>                      0: Not specified                      1: Specified</p> <table border="1"> <thead> <tr> <th></th> <th>b15</th> <th>b14</th> <th>b13</th> <th>b12</th> <th>to</th> <th>b3</th> <th>b2</th> <th>b1</th> <th>b0</th> </tr> </thead> <tbody> <tr> <td>(S3)+0</td> <td>16</td> <td>15</td> <td>14</td> <td>13</td> <td>to</td> <td>4</td> <td>3</td> <td>2</td> <td>1</td> </tr> <tr> <td>(S3)+1</td> <td>32</td> <td>31</td> <td>30</td> <td>29</td> <td>to</td> <td>20</td> <td>19</td> <td>18</td> <td>17</td> </tr> <tr> <td>(S3)+2</td> <td>48</td> <td>47</td> <td>46</td> <td>45</td> <td>to</td> <td>36</td> <td>35</td> <td>34</td> <td>33</td> </tr> <tr> <td>(S3)+3</td> <td>64</td> <td>63</td> <td>62</td> <td>61</td> <td>to</td> <td>52</td> <td>51</td> <td>50</td> <td>49</td> </tr> </tbody> </table> <p>1 to 64 in the table indicate station numbers.                      Default parameter setting is "0: Not specified" for all stations.</p>		b15	b14	b13	b12	to	b3	b2	b1	b0	(S3)+0	16	15	14	13	to	4	3	2	1	(S3)+1	32	31	30	29	to	20	19	18	17	(S3)+2	48	47	46	45	to	36	35	34	33	(S3)+3	64	63	62	61	to	52	51	50	49	—	User
	b15	b14	b13	b12	to	b3	b2	b1	b0																																													
(S3)+0	16	15	14	13	to	4	3	2	1																																													
(S3)+1	32	31	30	29	to	20	19	18	17																																													
(S3)+2	48	47	46	45	to	36	35	34	33																																													
(S3)+3	64	63	62	61	to	52	51	50	49																																													

\*5 Perform the settings for station numbers up to the largest station number set by the slave station setting data.

\*6 Specify only the head station number of a module in the case of a remote station, local station or intelligent device station that occupies 2 or more stations.

Error invalid station specification data

Device	Item	Set data	Setting range	Set by																																																		
(S4) + 0 ⋮ (S4) + 3	Setting for 1 to 64 modules <sup>*7</sup>	<p>Specify the error invalid station.<sup>*8</sup>                      0: Not specified                      1: Specified</p> <table border="1"> <thead> <tr> <th></th> <th>b15</th> <th>b14</th> <th>b13</th> <th>b12</th> <th>to</th> <th>b3</th> <th>b2</th> <th>b1</th> <th>b0</th> </tr> </thead> <tbody> <tr> <td>(S4)+0</td> <td>16</td> <td>15</td> <td>14</td> <td>13</td> <td>to</td> <td>4</td> <td>3</td> <td>2</td> <td>1</td> </tr> <tr> <td>(S4)+1</td> <td>32</td> <td>31</td> <td>30</td> <td>29</td> <td>to</td> <td>20</td> <td>19</td> <td>18</td> <td>17</td> </tr> <tr> <td>(S4)+2</td> <td>48</td> <td>47</td> <td>46</td> <td>45</td> <td>to</td> <td>36</td> <td>35</td> <td>34</td> <td>33</td> </tr> <tr> <td>(S4)+3</td> <td>64</td> <td>63</td> <td>62</td> <td>61</td> <td>to</td> <td>52</td> <td>51</td> <td>50</td> <td>49</td> </tr> </tbody> </table> <p>1 to 64 in the table indicate station numbers.                      Default parameter setting is "0: Not specified" for all stations.</p>		b15	b14	b13	b12	to	b3	b2	b1	b0	(S4)+0	16	15	14	13	to	4	3	2	1	(S4)+1	32	31	30	29	to	20	19	18	17	(S4)+2	48	47	46	45	to	36	35	34	33	(S4)+3	64	63	62	61	to	52	51	50	49	—	User
	b15	b14	b13	b12	to	b3	b2	b1	b0																																													
(S4)+0	16	15	14	13	to	4	3	2	1																																													
(S4)+1	32	31	30	29	to	20	19	18	17																																													
(S4)+2	48	47	46	45	to	36	35	34	33																																													
(S4)+3	64	63	62	61	to	52	51	50	49																																													

\*7 Perform the settings for station numbers up to the largest station number set by the slave station setting data.

\*8 Specify only the head station number of a module in the case of a remote station, local station or intelligent device station that occupies 2 or more stations.

The reserved station specification is given the higher priority if both error invalid station and reserved station specifications are made for the same station.

Send, receive and automatic refresh buffer assignment data

Device	Item	Set data	Setting range	Set by																	
(S5) + 0 ⋮ (S5) + 77	Setting for 1 to 26 modules*9	<p>Specify assignments of buffer memory size at transient transmission to local stations and intelligent device stations.</p> <table border="1"> <tr> <td>(S5)+0</td> <td>Send buffer size</td> <td rowspan="3">} Settings for the first module</td> </tr> <tr> <td>(S5)+1</td> <td>Receive buffer size</td> </tr> <tr> <td>(S5)+2</td> <td>Automatic refresh buffer size</td> </tr> <tr> <td colspan="3" style="text-align: center;">to</td> </tr> <tr> <td>(S5)+75</td> <td>Send buffer size</td> <td rowspan="3">} Settings for the 26th module</td> </tr> <tr> <td>(S5)+76</td> <td>Receive buffer size</td> </tr> <tr> <td>(S5)+77</td> <td>Automatic refresh buffer size</td> </tr> </table> <p>The default parameter settings are "send buffer size: 40<sub>H</sub>, receive buffer size: 40<sub>H</sub>, automatic refresh buffer size: 80<sub>H</sub>."</p>	(S5)+0	Send buffer size	} Settings for the first module	(S5)+1	Receive buffer size	(S5)+2	Automatic refresh buffer size	to			(S5)+75	Send buffer size	} Settings for the 26th module	(S5)+76	Receive buffer size	(S5)+77	Automatic refresh buffer size	<p>Send/receive buffer*10 : 0<sub>H</sub> (no setting), 40<sub>H</sub> to 1000<sub>H</sub> 0 (word) (no setting) 64 to 4096 (words)</p> <p>Automatic refresh buffer*11 : 0<sub>H</sub> (no setting), 80<sub>H</sub> to 1000<sub>H</sub> 0 (word) (no setting) 128 to 4096 (words)</p>	User
(S5)+0	Send buffer size	} Settings for the first module																			
(S5)+1	Receive buffer size																				
(S5)+2	Automatic refresh buffer size																				
to																					
(S5)+75	Send buffer size	} Settings for the 26th module																			
(S5)+76	Receive buffer size																				
(S5)+77	Automatic refresh buffer size																				

- \*9 Perform the settings for stations specified as local stations or intelligent device stations in the slave station setting data, starting from the smallest station number.
- \*10 Keep the total size of the send and receive buffer sizes at 1000<sub>H</sub> (4096 (words)) or less.  
Specify the size of data to be sent and received plus 7 words for the send and receive buffer sizes, respectively.  
Setting a value outside the setting range results in abnormal completion.
- \*11 Keep the total size of the automatic refresh buffer sizes at 1000<sub>H</sub> (4096 (words)) or less.  
Specify the necessary automatic refresh buffer size for each intelligent device station.  
Setting a value outside the setting range results in abnormal completion.

## (1) Functions

### (a) Operation chart for the G(P).RLPASET instruction.

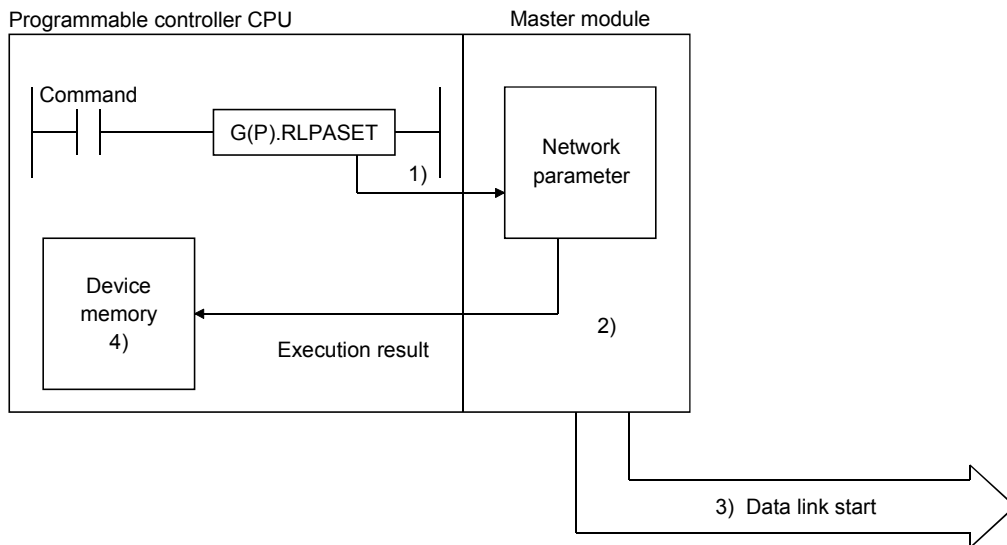

- 1) Pass the network parameters set in (S1) to (S5) to the master module specified by Un.
- 2) The master module analyzes the settings of the network parameters.
- 3) If the network parameter settings are correct, the data link is started.
- 4) The device specified by (D) turns on.

### (b) It is only possible to execute one G(P).RLPASET instruction at a time.

### (c) There are two types of interlock signals for the G(P).RLPASET instruction: the completion device (D) and status display device at completion (D) + 1.

- Completion device  
Turns ON in the END Processing of the scan where the G(P).RLPASET instruction is completed, and turns OFF in the next END processing.
- Status display device at completion  
Turns On and OFF depending on the completion status of the G(P).RLPASET instruction.  
Normal completion: Stays OFF and does not change.  
Abnormal completion: Turns ON in the END processing of the scan where the G(P).RLPASET instruction is completed, and turns OFF in the next END processing.



**(d) After executing the G(P).RLPASET instruction, turn on SB0003 (refresh instruction) to refresh cyclic data.**

[When all the stations are normal]

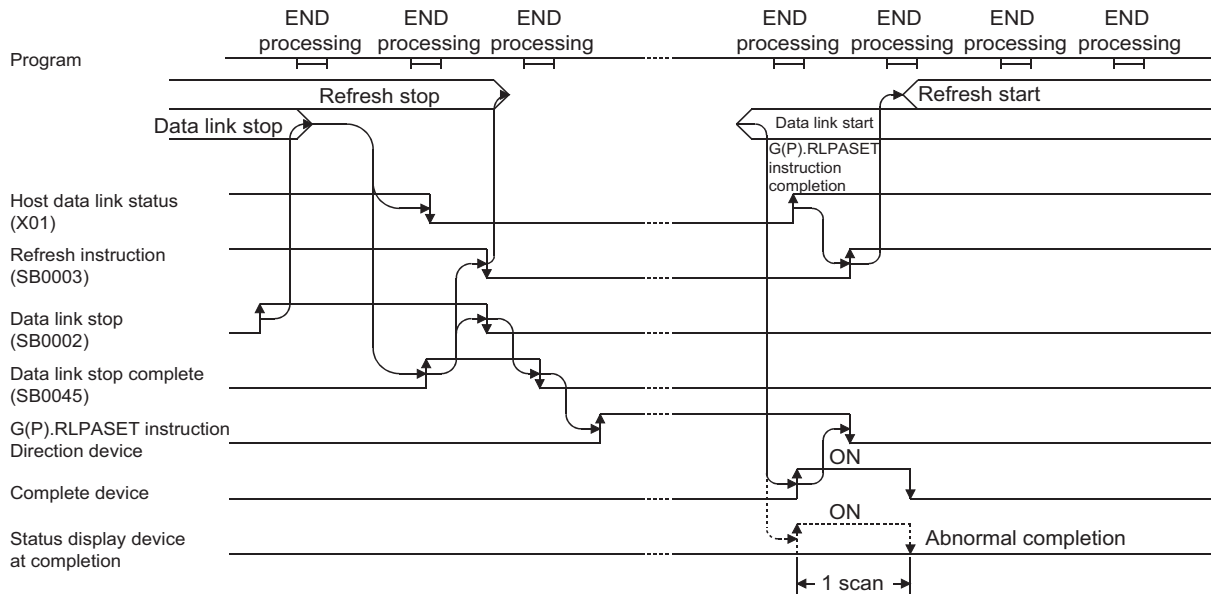

[When all the stations are faulty]

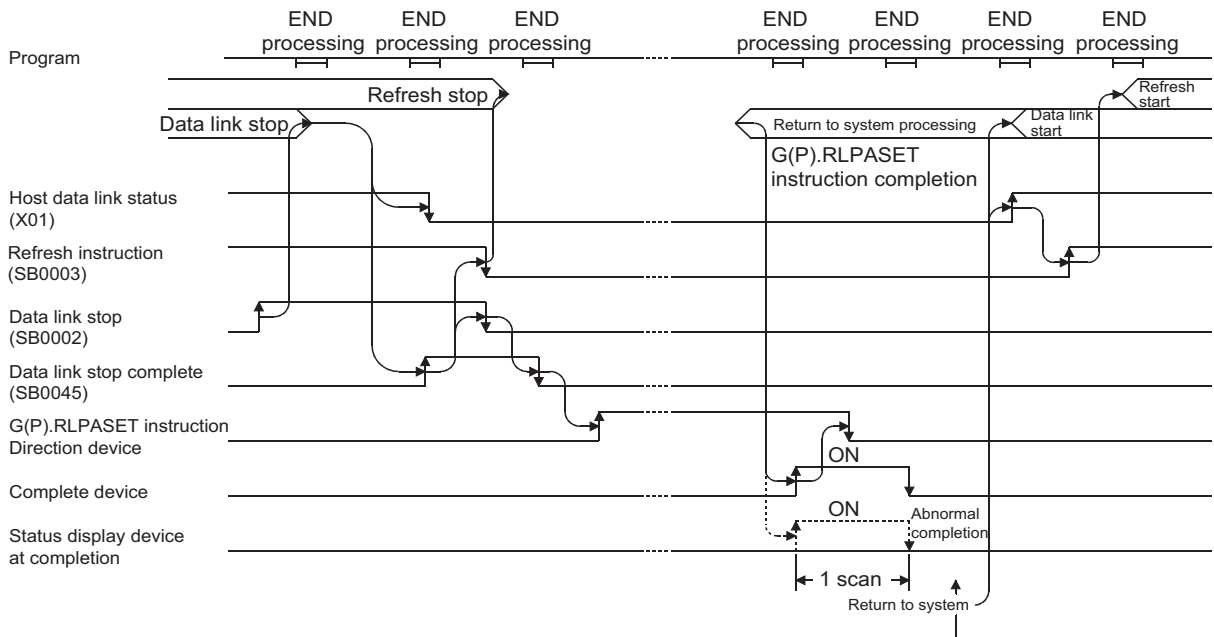

9.1 Dedicated Instructions  
9.1.8 G(P).RLPASET

## (2) Operation error

In the following cases, an operation error occurs; the error flag (SM0) turns ON and the error code is stored in SD0.

Error code	Description of operation error
2112	When the module specified by Un is not an intelligent function module.
	When the module specified by Un is not a special function module.
4002	When an attempt was made to execute an unsupported instruction.
4003	When the number of devices in the instruction is incorrect.
4004	When the instruction specifies a device that cannot be used.
4100	When the instruction contains the data cannot be used.
4101	<p>When the number of points for data used in the instruction exceeds the available range, or storage data and constants of a device specified by the instruction exceeds the available range (including dummy devices).</p> <p>The number of points required for each data is shown below.</p> <ul style="list-style-type: none"><li>• Control data: 8 points</li><li>• Slave station setting data: 64 points</li><li>• Reserved station specification data: 4 points</li><li>• Error invalid station specification data: 4 points</li><li>• Send, receive and automatic refresh buffer assignment data: 78 points</li></ul> <p>Example: Assume that data registers D0 to D12287 are available for the L02CPU. If the device head number of the slave station setting data is set to D12284 when there are only 4 slave stations, an error indicating that the available range is exceeded occurs because the programmable controller CPU checks the range from D12284 to D12347 (for 64 stations).</p>

### (3) Example of Parameter setting/Program

This program sets the network parameters for the master module mounted at the I/O numbers X/Y00 to X/Y1F and starts the data link.

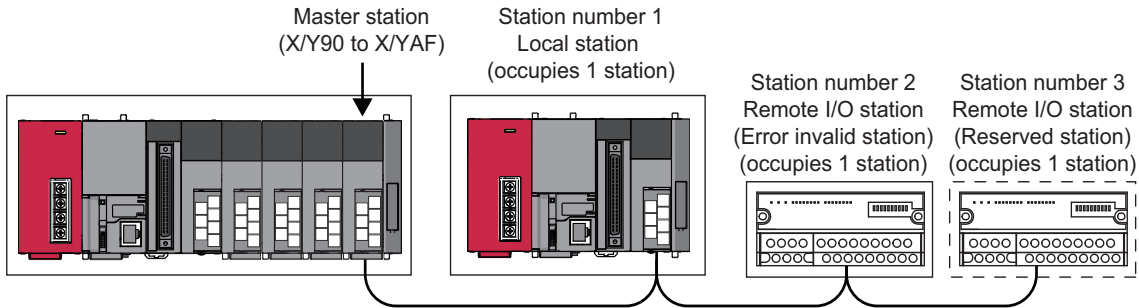

(a) PLC parameter setting

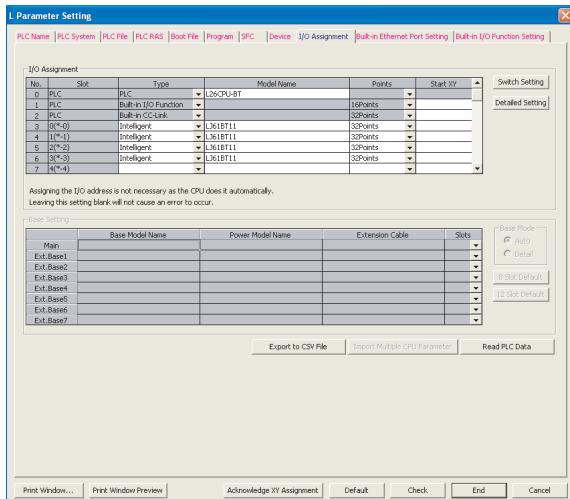

#### 1. I/O assignment setting window

Set the following for the master module.

The type setting is required; set other items as needed.

Type: Select "Intelligent"

Model name: Enter the module model name.

Points: Select 32 points

Start XY: Enter the start I/O number for the master module.

#### 2. Intelligent function module switch setting

Click the Switch Setting button in the I/O assignment setting window to display the window shown to the left.

Set the input format to hexadecimal and enter values for switches 1 to 4. The switch settings are indicated in the following table.

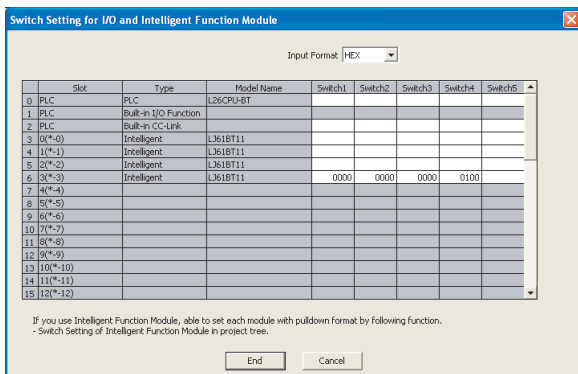

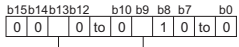
	Description	Setting range
Switch 1 <sup>*1</sup>	Set the transmission speed. <ul style="list-style-type: none"> <li>• 156kbps: 0000<sub>H</sub></li> <li>• 625kbps: 0001<sub>H</sub></li> <li>• 2.5Mbps: 0002<sub>H</sub></li> <li>• 5Mbps: 0003<sub>H</sub></li> <li>• 10Mbps: 0004<sub>H</sub></li> </ul>	0000 <sub>H</sub> to 0004 <sub>H</sub>
Switch 2 <sup>*1</sup>	Set 0000 <sub>H</sub> .	Fixed to 0000 <sub>H</sub>
Switch 3 <sup>*1</sup>	Set the mode of the L series master/local module. (Mode) <ul style="list-style-type: none"> <li>• Remote net ver.2 mode: 0000<sub>H</sub></li> <li>• Remote net ver.2 mode: 0200<sub>H</sub></li> <li>• Remote net additional mode: 0100<sub>H</sub></li> </ul>	0000 <sub>H</sub> , 0200 <sub>H</sub> , and 0100 <sub>H</sub>
Switch 4 <sup>*1</sup>	Set the "Case of CPU STOP Setting" and the "Connected Devices Auto-detection" setting <sup>*3</sup> .   <p style="margin-left: 40px;"> Setting at the CPU STOP  0: Refresh  1: Clear compulsorily.  Connected devices auto-detection setting  0: Not read the model name of the slave stations  1: Read the model name of the slave stations </p>	0100 <sub>H</sub> , 0300 <sub>H</sub> , 2100 <sub>H</sub> , 2300 <sub>H</sub>
Switch 5 <sup>*2</sup>	Blank	Fixed to blank

- \*1 If switches 1 to 4 have not been set or the settings are not as listed above, the G(P).RLPASET instruction ends abnormally.  
In this case, the L series master/local module with the smallest start I/O number seen from the programmable controller CPU starts CC-Link automatically.
- \*2 Do not configure any settings for the switch 5. Normal operation is not guaranteed if the settings for the switch 5 are configured.
- \*3 The setting is available only in an L series master/local module with a serial number (first five digits) of 14112 or later.

(b) Program example

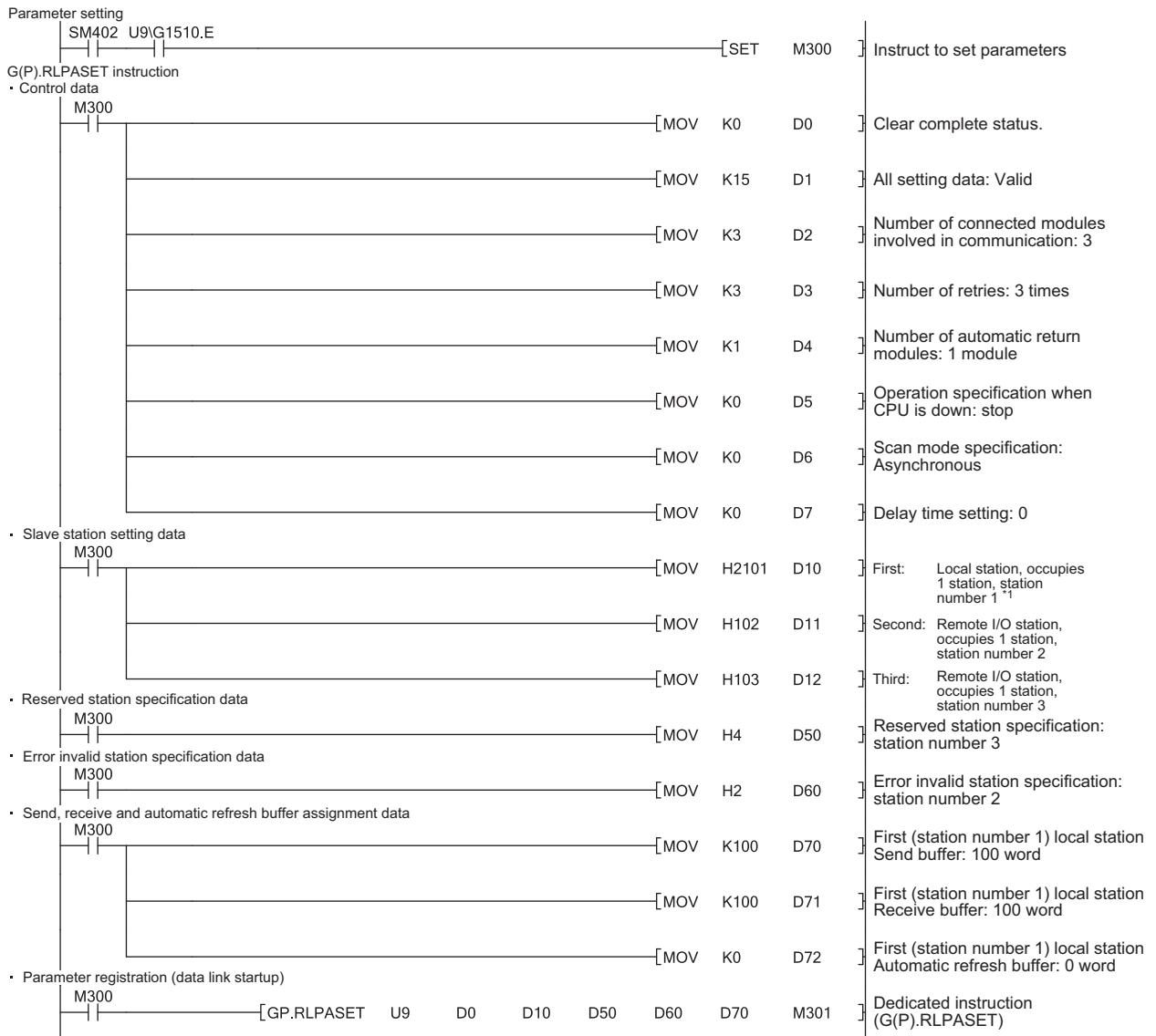

\*1 Set the station number in hexadecimal. (Example) Set 14<sub>H</sub> for station No. 20.

Processing at completion of the G(P).RLPASET instruction

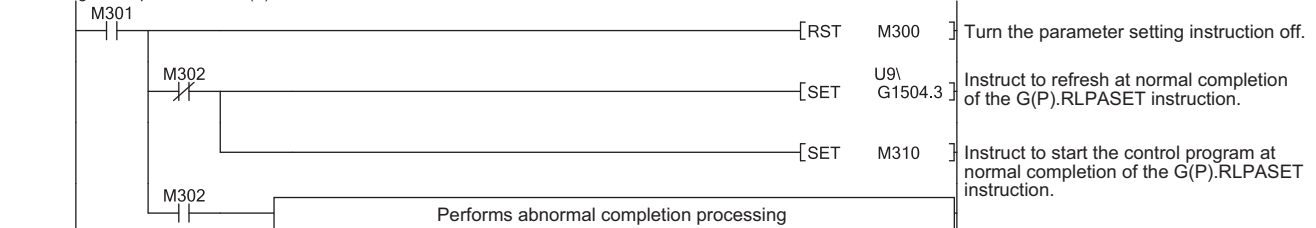

Parameter setting change

Parameter change instruction U9\G1510.E

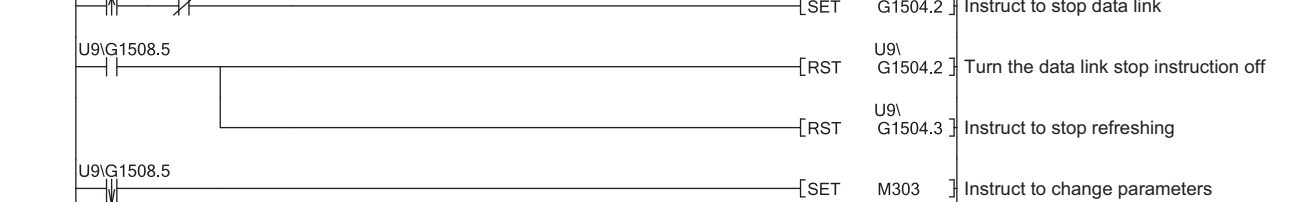

G(P).RLPASET instruction

• Control data

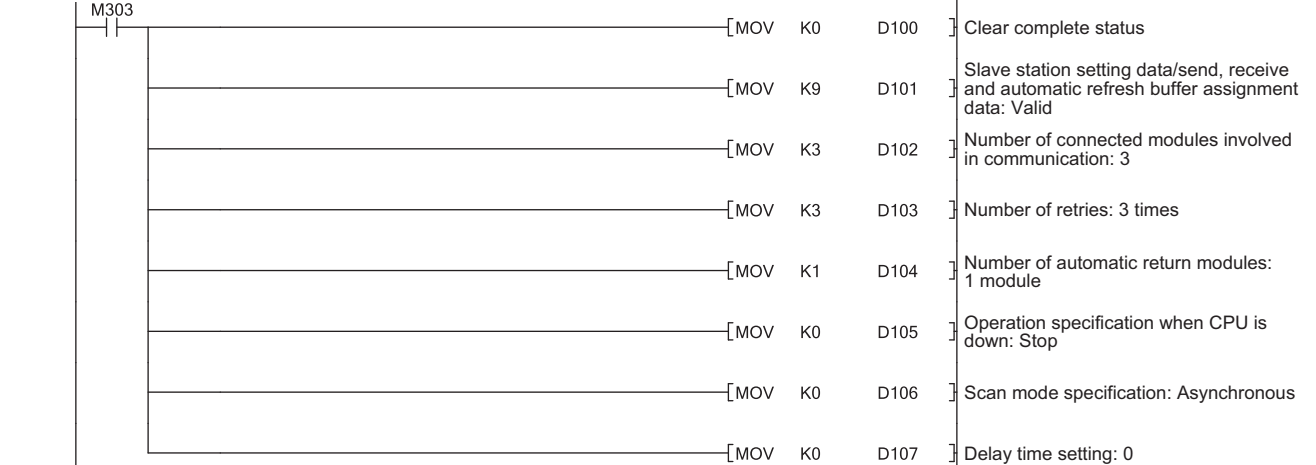

• Slave station setting data

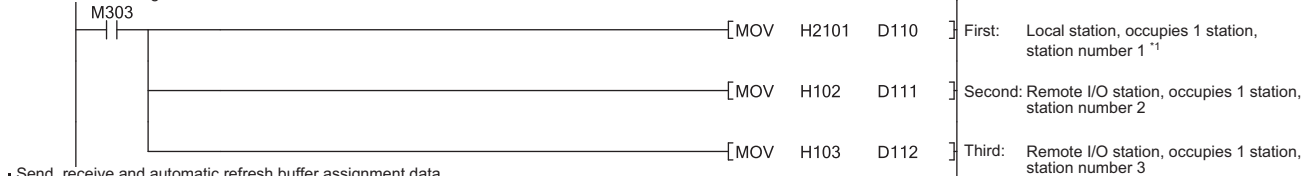

• Send, receive and automatic refresh buffer assignment data

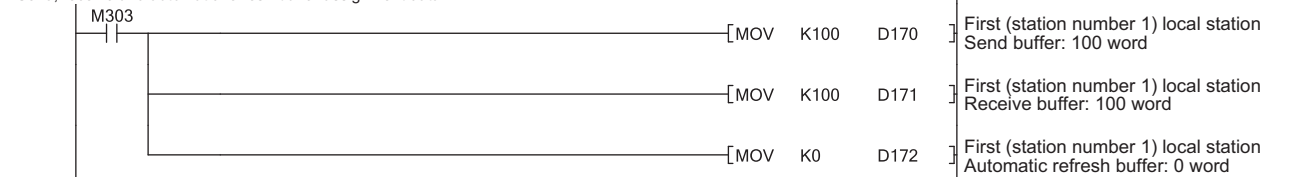

\*1 Set the station number in hexadecimal. (Example) Set 14<sub>H</sub> for station No. 20.



#### **(4) Precautions when using the G(P).RLPASET instruction to set the network parameters**

**(a) The remote I/O net mode cannot be used.**

The module operates in remote net mode.

**(b) If it is necessary to change the network parameters while the programmable controller CPU is running and the data link is being performed, the data link should be stopped once using SB0002 (data link stop).**

**(c) It is necessary to set I/O assignments for modules whose network parameters are set by the G(P).RLPASET instruction.**

In addition, do not use GX Works2 to set the network parameters and automatic refresh parameters for modules whose network parameters are set by the G(P).RLPASET instruction.

If the G(P).RLPASET instruction is used to set network parameters for modules whose network parameters and automatic refresh parameters have been set by GX Works2, the G(P).RLPASET instruction will complete with an error and the network parameter settings performed by the G(P).RLPASET instruction become invalid.

**(d) If the switch setting of an intelligent functional module for which an I/O assignment is set, has not been performed or is wrong, the G(P).RLPASET instruction completes with an error.**

However, the L series master/local module with the smallest head I/O number seen from the programmable controller CPU starts CC-Link automatically.

**(e) Do not use GX Works2 for setting the network parameters, if the network parameters of all the modules are set by the G(P).RLPASET instruction.**

Change the "Number of Modules" setting to blank if the network parameters have been already set by GX Works2.

Moreover, in case a system includes both a module for which the network parameters are set by GX Works2 and a module for which the network parameters are set by the G(P).RLPASET instruction, the module for which the network parameters are set by the G(P).RLPASET instruction should not be included in the "Number of Modules" setting of GX Works2.

**(f) After executing the G(P).RLPASET instruction, turn on SB0003 (refresh instruction) to refresh cyclic data.**

**(g) Automatic refresh is not performed.**

The devices should be refreshed via the FROM/TO instruction or the G device.

**(h) It is not possible to set input status from a data link faulty station.**

Inputs from a data link faulty station are cleared.

**(i) The standby master function is not available.**



- (j) In order to change the parameter setting method, turn the power supply to the programmable controller system off and back on, or reset the programmable controller CPU.**

The following table shows how the programmable controller CPU operates when changing the parameter setting method without turning the power supply to the programmable controller system off and back on, or resetting the programmable controller CPU.

Parameter setting method (before change)	Parameter setting method (after change)	Error notification method	Continuity of data link
Parameter setting with GX Works2	Parameter setting with the G(P).RLPASET instruction	The G(P).RLPASET instruction completes with an error.	Data link continues.
Parameter setting with the G(P).RLPASET instruction	Parameter setting with GX Works2	LINK.PARA.ERR occurs in the programmable controller CPU.	Data link stops.*1

\*1 Note that data link continues to be performed if the designation of operation at CPU down ((S1) + 5) of the G(P).RLPASET instruction is set to "Continue."

- (k) When the programmable controller CPU is switched from RUN to STOP, RY of the master station and outputs to the slave station are retained.**

## 9.1.9 G(P).RDMSG

This instruction reads/writes parameters from/to the remote device station and reads the status of the remote device station.

Available for communication with a remote device station that supports the message transmission function (e.g. NZ2AW1C2AL)

Set data	Usable devices									
	Internal device (System, user)		File register	Link direct device J□\□		Intelligent function module device U□\G□	Index register Z□	Constant		Other
	Bit	Word		Bit	Word			K, H	\$	
(S1)	—	○				—	—	—	—	
(S2)	—	○				—	—	—	—	
(D1)	—	○				—	—	—	—	
(D2)		○				—	—	—	—	

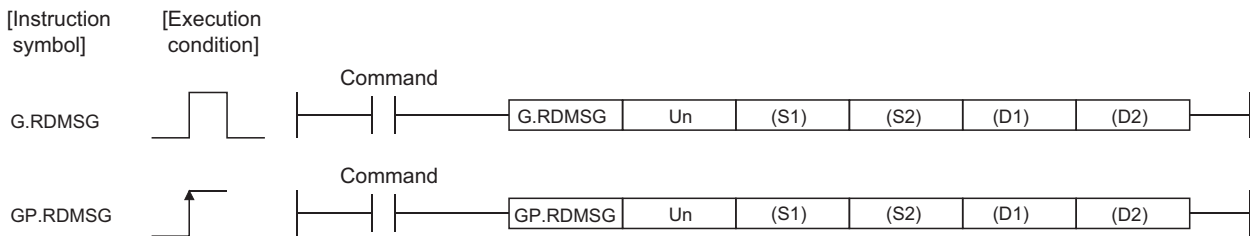

### Set data

Device *1	Description	Setting range	Data type
Un	Start I/O number of the module (First 2 digits of I/O No. with three digits)	0 to FE <sub>H</sub>	Binary 16 bits
(S1)	Start number of the device in which control data is stored.	Within the range of the specified device	Device name
(S2)*2	Start number of the device that stores data to be sent.	Within the range of the specified device	
(D1)*2	Start number of the device that stores received data.	Within the range of the specified device	
(D2)	Device that is turned ON for one scan upon completion of reading. (D2) + 1 also turns ON at an abnormal completion.	Within the range of the specified device	Bit

\*1 The file register of each of the local device and the program cannot be used as a device for setting data.

\*2 For details of the send data and receive data, refer to the manual for the remote device station that supports the message transmission function.

Control data

Device	Item	Set data	Setting range	Set by
(S1) + 0	Completion status	Stores the status when the instruction is complete. 0: No error (normal completion) Other than 0: Error code	—	System
(S1) + 1	Station number	Specifies the station number of the remote device station.	1 to 64	User
(S1) + 2	Send data size	Specifies a send data size (in bytes).	1 to 255	
(S1) + 3	Receivable data size	Specifies the maximum size of the device that stores received data (in bytes).	0 to 255	System
(S1) + 4	Receive data size	Stores the size of received data (in bytes).	—	

(1) Send data size

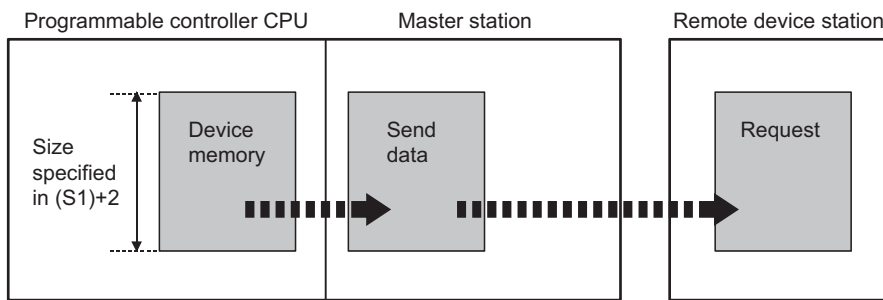

When the send data size ((S1)+2) is an odd number of bytes, the low byte of the last data is sent as the last byte.

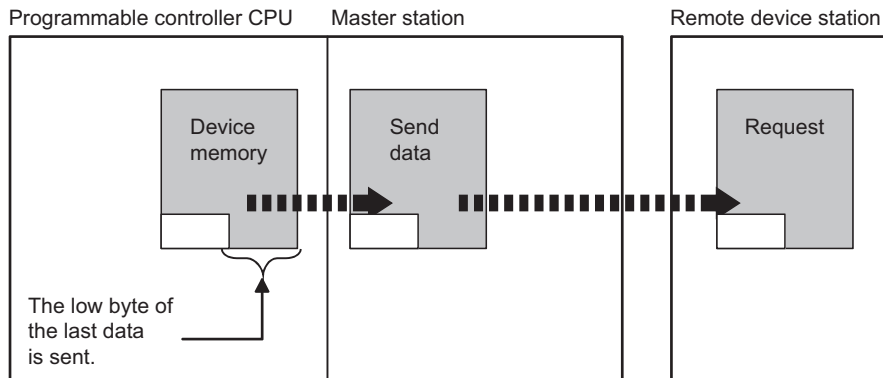

## (2) Receivable data size and receive data size

Set a receivable data size  $((S1)+3)$  so that it will satisfy the following conditional expression: Receivable data size  $((S1)+3) \geq$  Receive data size  $((S1)+4)$

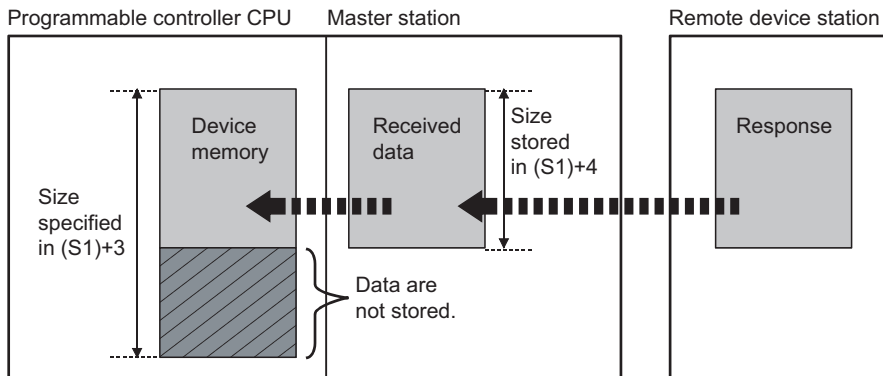

If the receivable data size  $((S1)+3)$  is smaller than the receive data size  $((S1)+4)$ , data sent from a remote device station cannot be received. The G(P).RDMSG instruction will fail (error code: B418<sub>H</sub>).

- When the receivable data size  $((S1)+3)$  is an odd number of bytes

If the receivable data size  $((S1)+3)$  is an odd number of bytes and the same data size is received, 0 is stored in the high byte of storage area of the last data.

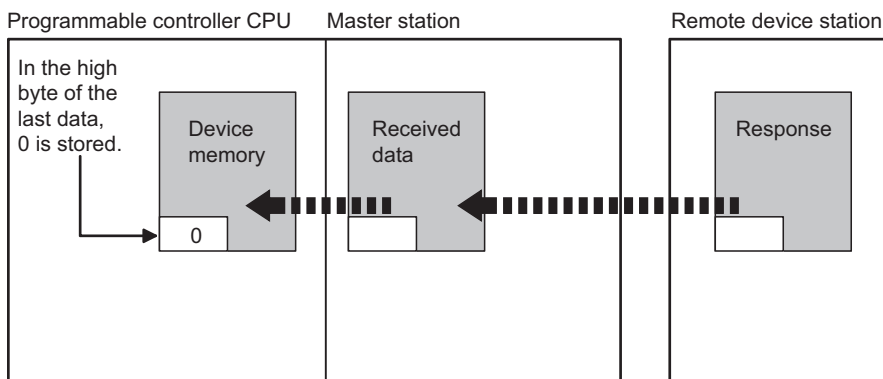

- When the receive data size  $((S1)+4)$  is an odd number of bytes (when data received from a remote device station is an odd number of bytes in length)

If the receive data size is an odd number of bytes, the last receive data is stored in the lower byte of storage area of the last data. Also, 0 is stored in the high byte of storage area of the last data.

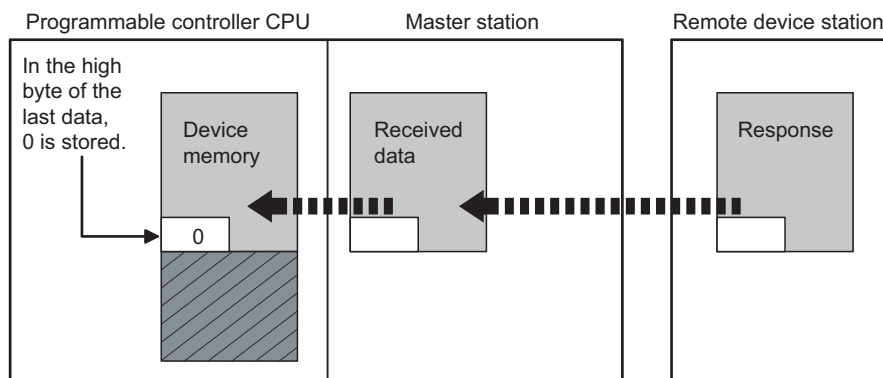

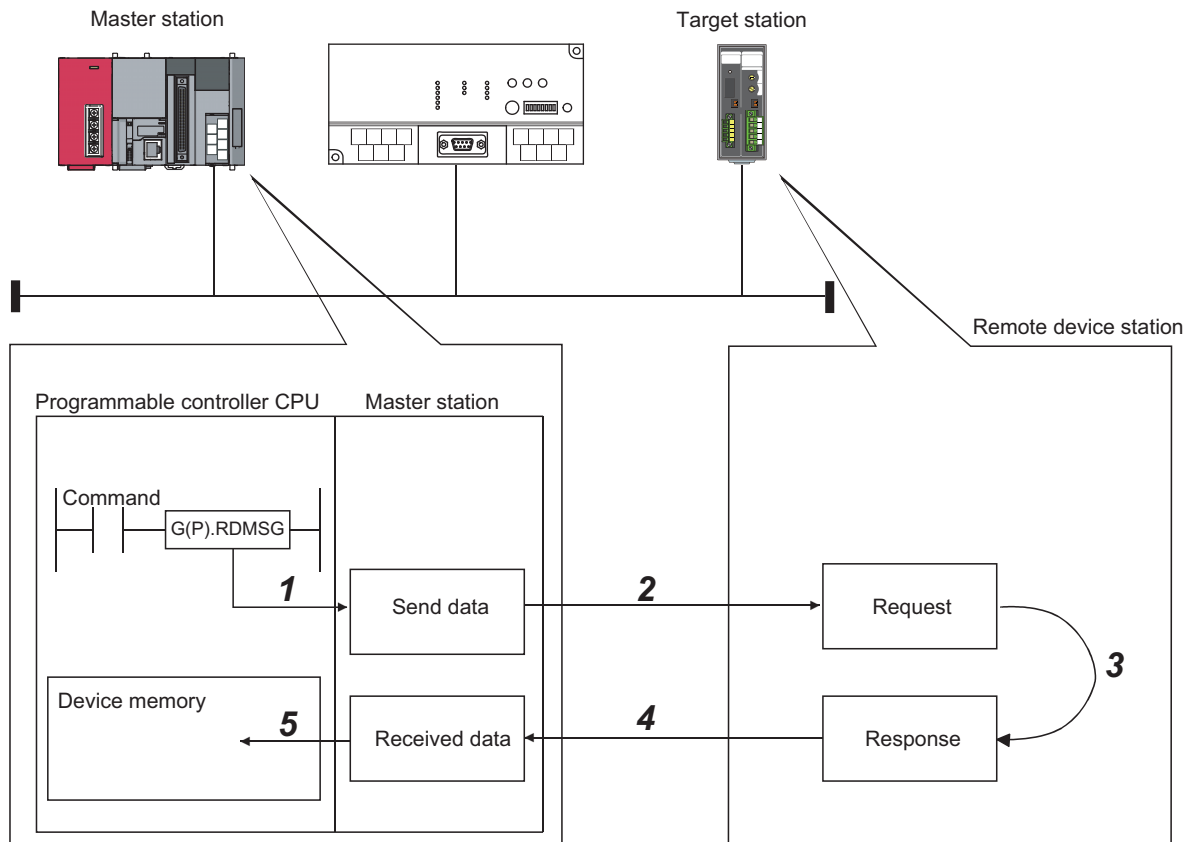
**(3) Functions****(a) Operation chart of the G(P).RDMSG instruction**

- 1.** The send data (S2) in the size specified in (S1)+2 are stored into the master station.
- 2.** The send data are sent to the station specified in (S1)+1.
- 3.** Processing for the send data is executed at the station specified in (S1)+1.
- 4.** A processing result is received from the station specified in (S1)+1.
- 5.** The received data are stored in the area from the device specified in (D1), and the device specified in (D2) is set to ON.

**(b) The G(P).RDMSG instruction can be simultaneously executed to multiple remote device stations (up to four stations).**

To the same remote device station, however, simultaneous execution of multiple instructions including other dedicated instruction(s) is not allowed. Because several scans are required to complete the process of the dedicated instruction, create a program so that the next dedicated instruction is executed after Completion device (D2) turns on.

**(c) There are two types of interlock signals for the G(P).RDMSG instruction: Completion device (D2) and Status display device at completion (D2)+1.**

- Completion device  
Turns on in the END process of the scan where the G(P).RDMSG instruction is completed, and turns off in the next END process.
- Status display device at completion  
Turns on and off depending on the completion status of the G(P).RDMSG instruction.  
Normal completion: Remains off and does not change.  
Abnormal end: Turns on in the END process of the scan where the G(P).RDMSG instruction is completed, and turns off in the next END process.

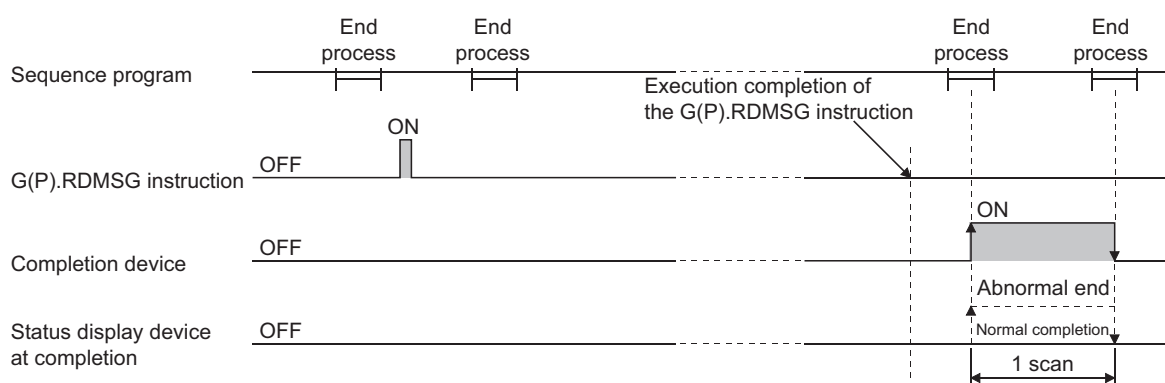

**(d) The basic number of steps of the G(P).RDMSG instruction is ten.**

**(4) Operation error**

In the following cases, an operation error occurs; the error flag (SM0) turns ON and the error code is stored in SD0.

Error code	Description of operation error
2112	When the module specified by Un is not an intelligent function module
	When the module specified by Un is not a special function module
4002	When an attempt was made to execute an unsupported instruction
4003	When the number of devices in the instruction is incorrect
4004	When the instruction specifies a device that cannot be used
4100	When the instruction contains the data that cannot be used
4101	When the number of data set to be used exceeds the allowable range.
	Or, when the storage data or constants of the device specified with the instruction exceeds the allowable range.

**(5) Program example**

For the RDMSG instruction, some or all remote registers which are executing the cyclic transmission between the master station and target station are used in the system. For program examples, refer to the manual for the remote device station that supports the message transmission function.

In addition, add the Remote register use prohibited status (SW0160 to SW0163) to the program as an interlock.

## 9.2 Precautions on Programming

The following explains precautions on the creation of a program:

Create a program that allows the detection of data-link status and interlocking with the slave stations.

In addition, create an error-handling program.

[Program example]

Set the "Special Relay(SB)" of the master station to "SB0" and the "Special Register(SW)" to "SW0", with GX Works2.

### Point

When setting the special relay (SB) refresh device and special register (SW) refresh device to SB/SW respectively, make sure that their device numbers do not duplicate with those used in other networks.

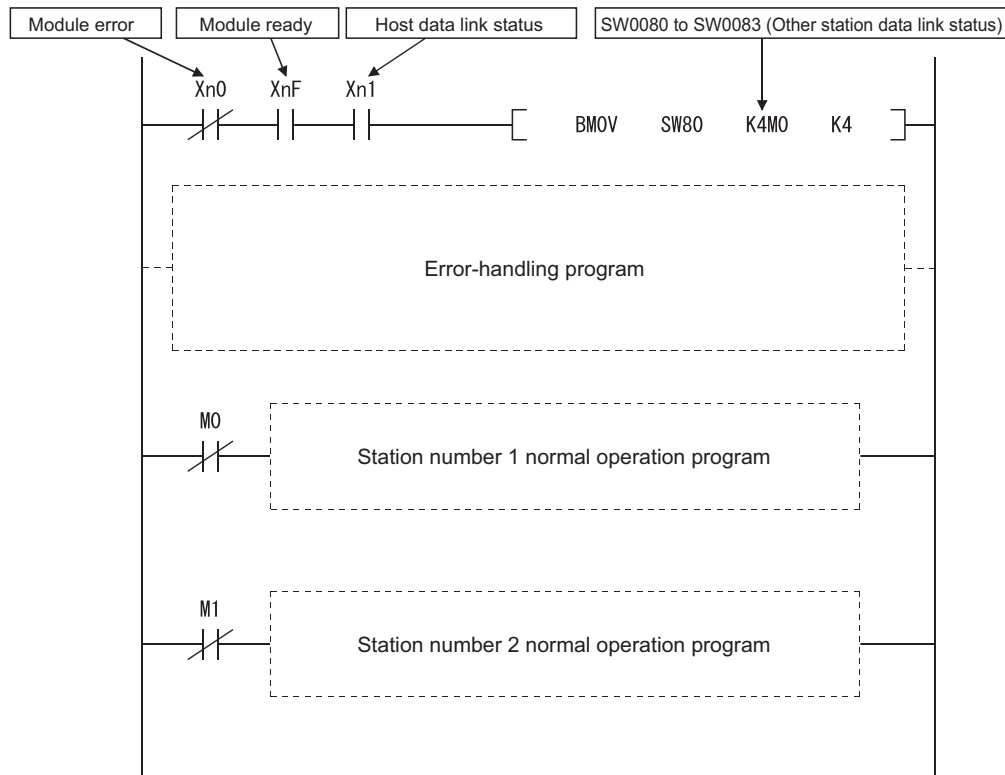

# CHAPTER 10 EXAMPLE OF COMMUNICATION BETWEEN THE MASTER STATION AND REMOTE I/O STATIONS

This chapter explains the procedures from module settings to parameter settings, programming, and finally operation check using a system configuration example.

## 10.1 When Remote I/O Net Mode is Used

The remote I/O net mode is used.

### 10.1.1 Configuring a system

As shown below, a system with three remote I/O stations is used as an example.

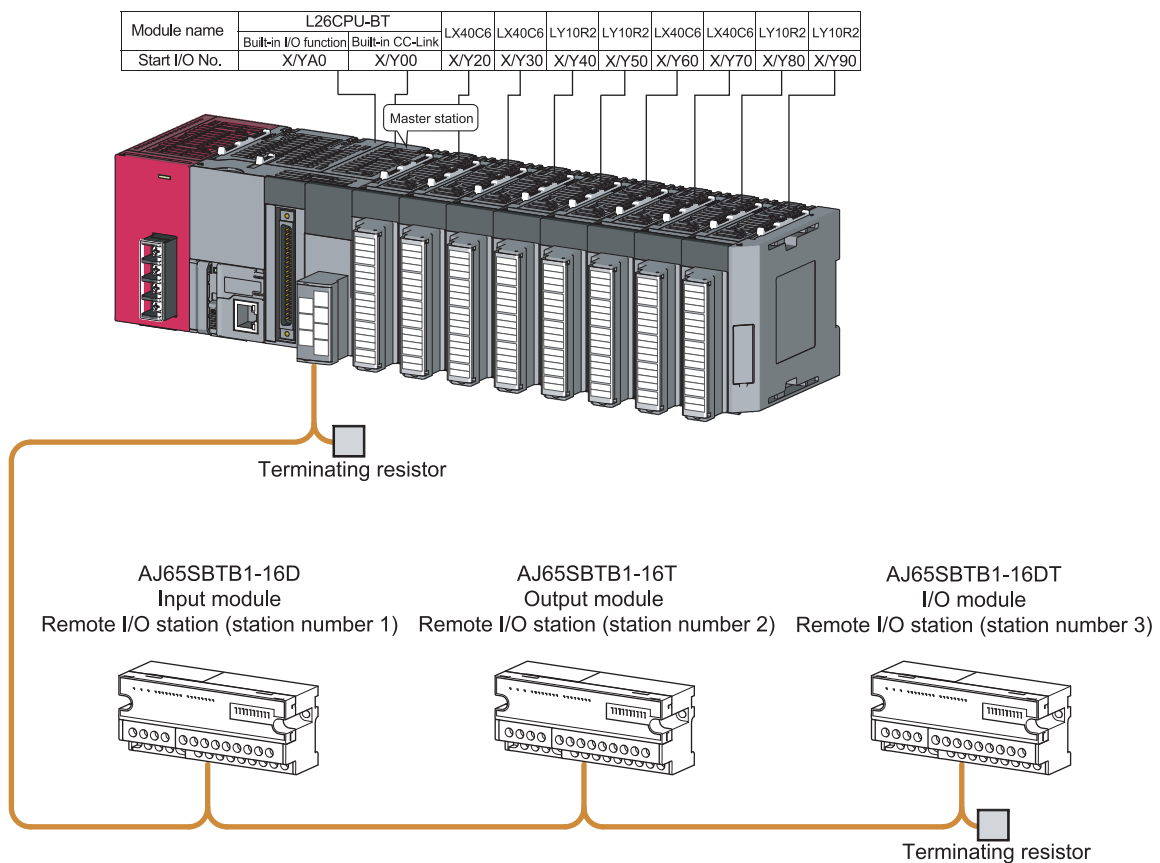



### (1) Setting the remote I/O stations

Settings of the remote I/O station switches are shown below:

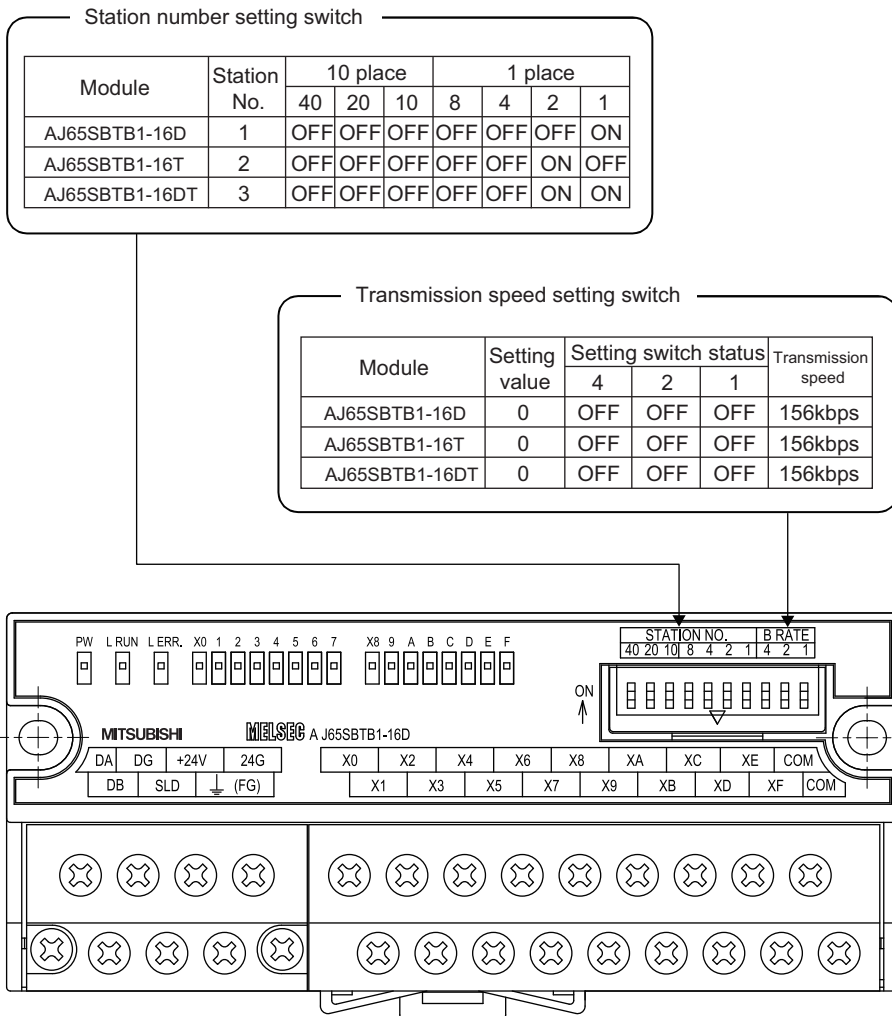

10.1 When Remote I/O Net Mode is Used  
10.1.1 Configuring a system

## 10.1.2 Parameter setting

### (1) Setting the network parameters and automatic refresh parameters of the master station

Set the network parameters and automatic refresh parameters as follows.

For the operation setting, refer to  Page 245, Section 10.1.2 (2).

	1	
Start I/O No.	0000	
Operation Setting	Operation Setting	← Refer to Section 10.1.2 (2).
Type	Master Station	
Station No.	0	
Master Station Data Link Type	PLC Parameter Auto Start	
Mode	Remote I/O Net Mode	
Transmission Speed	156kbps	
Total Module Connected	3	
Remote Input(RX)	X1000	
Remote Output(RY)	Y1000	
Remote Register(RWr)		
Remote Register(RWw)		
Ver.2 Remote Input(RX)		
Ver.2 Remote Output(RY)		
Ver.2 Remote Register(RWr)		
Ver.2 Remote Register(RWw)		
Special Relay(SB)	SB0	
Special Register(SW)	SW0	
Retry Count		
Automatic Reconnection Station Count		
Standby Master Station No.		
PLC Down Select	Stop	
Scan Mode Setting	Asynchronous	
Delay Time Setting		
Station Information Setting		
Remote Device Station Initial Setting		
Interrupt Setting	Interrupt Setting	

#### Point

Do not set the same refresh devices as the following.

- Refresh parameters of modules on the network
- I/O numbers used for an I/O module and an intelligent function module
- Auto refresh settings of an intelligent function module

**(2) Operation setting**

Set the operation settings as follows.

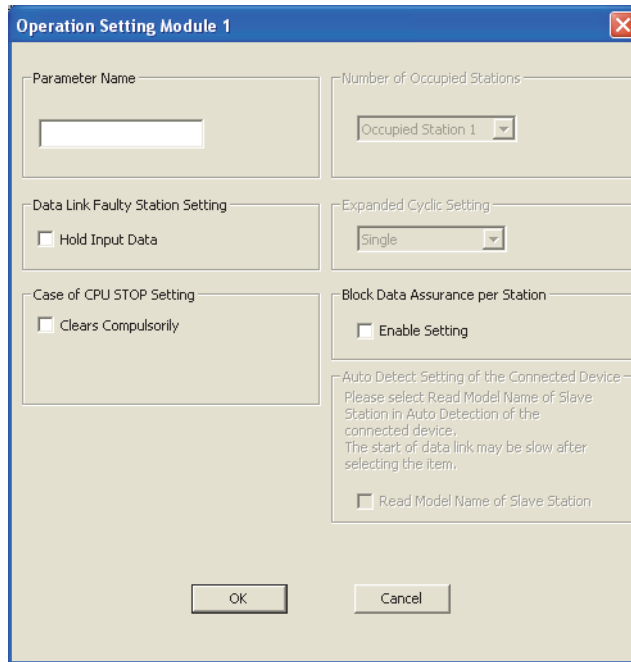

# 10.1.3 Creating a program

This section shows the program used to control the remote I/O stations. The following diagram shows the relationship between the devices of the programmable controller CPU and the inputs/outputs of remote I/O stations. The shaded areas indicate the devices that are actually used.

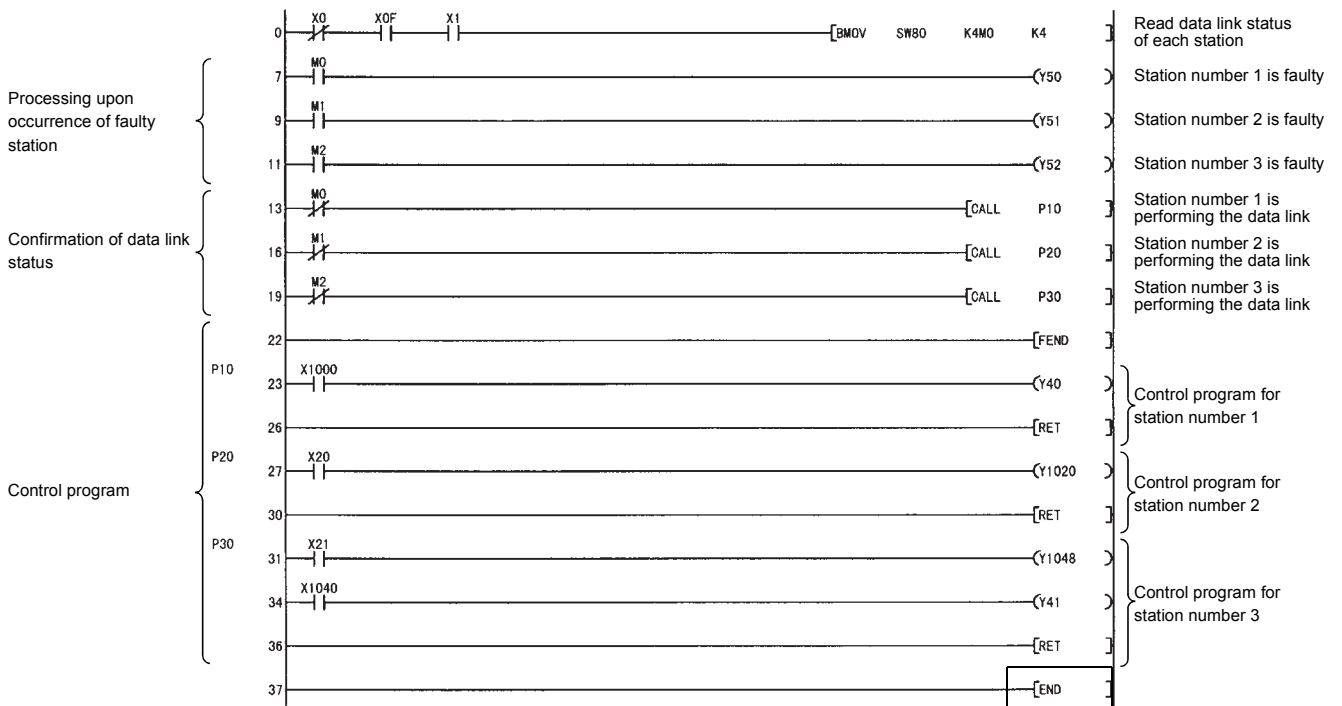
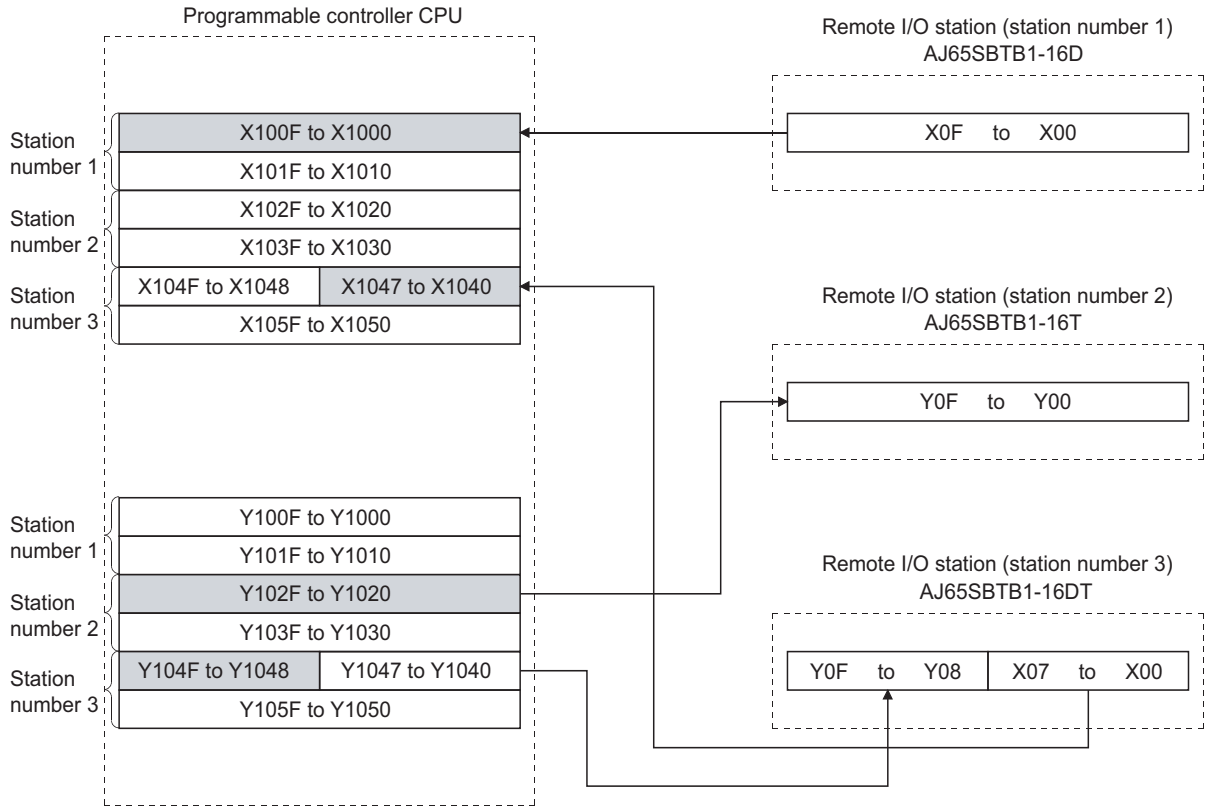

# 10.1.4 Performing the data link

Turn on the remote I/O stations first, and then the master station to start the data link.

## (1) Confirming the operation with the LED indicators

The following diagram shows the LED status of the master station and the remote I/O station when the data link is being performed normally.

### (a) LED indication of the master station

Make sure that the LEDs are as follows:

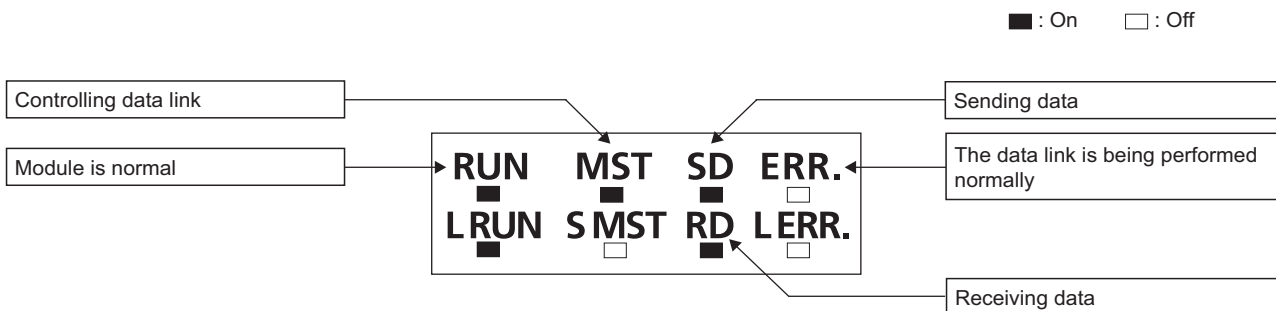

### (b) LED indication of the remote I/O station

Make sure that the LEDs are as follows:

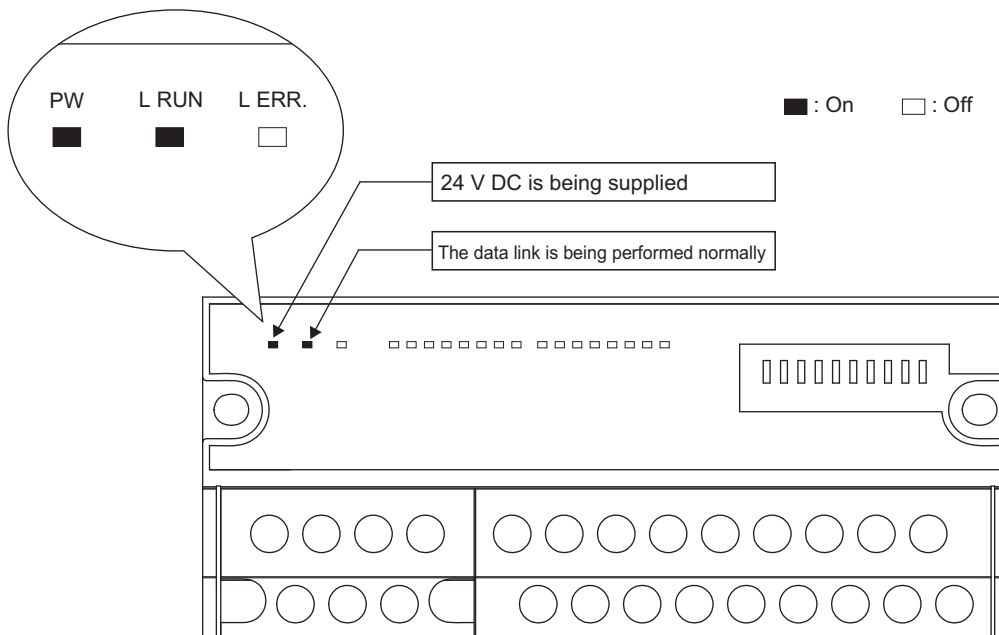

10.1 When Remote I/O Net Mode is Used  
10.1.4 Performing the data link

## (2) Confirming the operation with the program

Using the program, confirm that the data link is being performed normally.

1) For example, when X00 of the remote I/O station AJ65SBTB1-16D (station number 1) is turned on, Y40 (LY10R2) of the master station turns on.

2) When X21 (LX40C6) of the master station is turned on, Y08 of the remote I/O station AJ65SBTB1-16DT (station number 3) turns on.

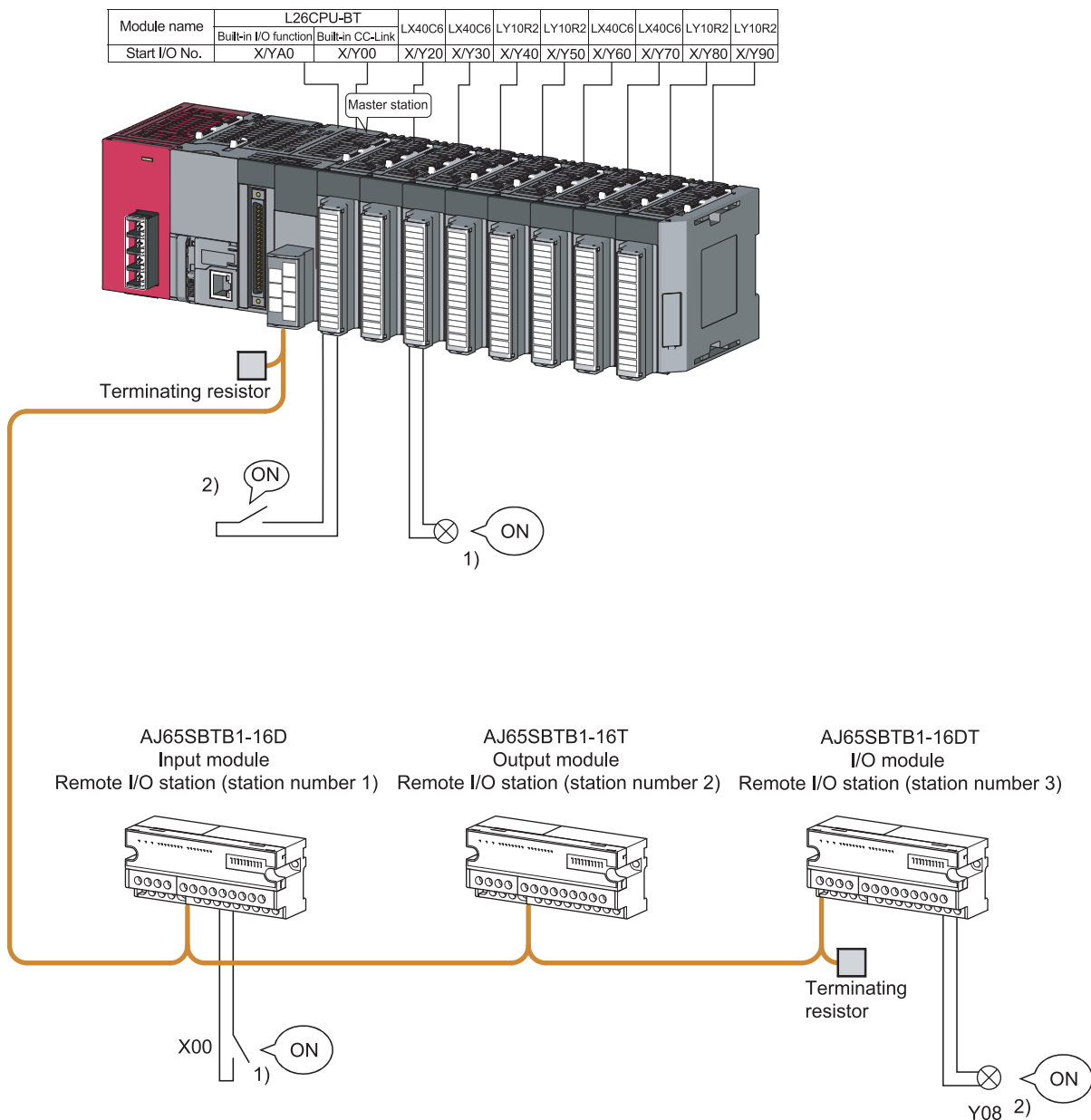

# CHAPTER 11 EXAMPLE OF COMMUNICATION BETWEEN THE MASTER STATION AND REMOTE DEVICE STATIONS

This chapter explains the procedures from module settings to parameter settings, programming, and finally operation check using a system configuration example.

For more detailed information on remote device stations, refer to the User's Manual for the remote device stations.

## 11.1 When Remote Net Ver.1 Mode is Used

### 11.1.1 Configuring a system

As shown below, a system with one remote I/O station is used as an example.

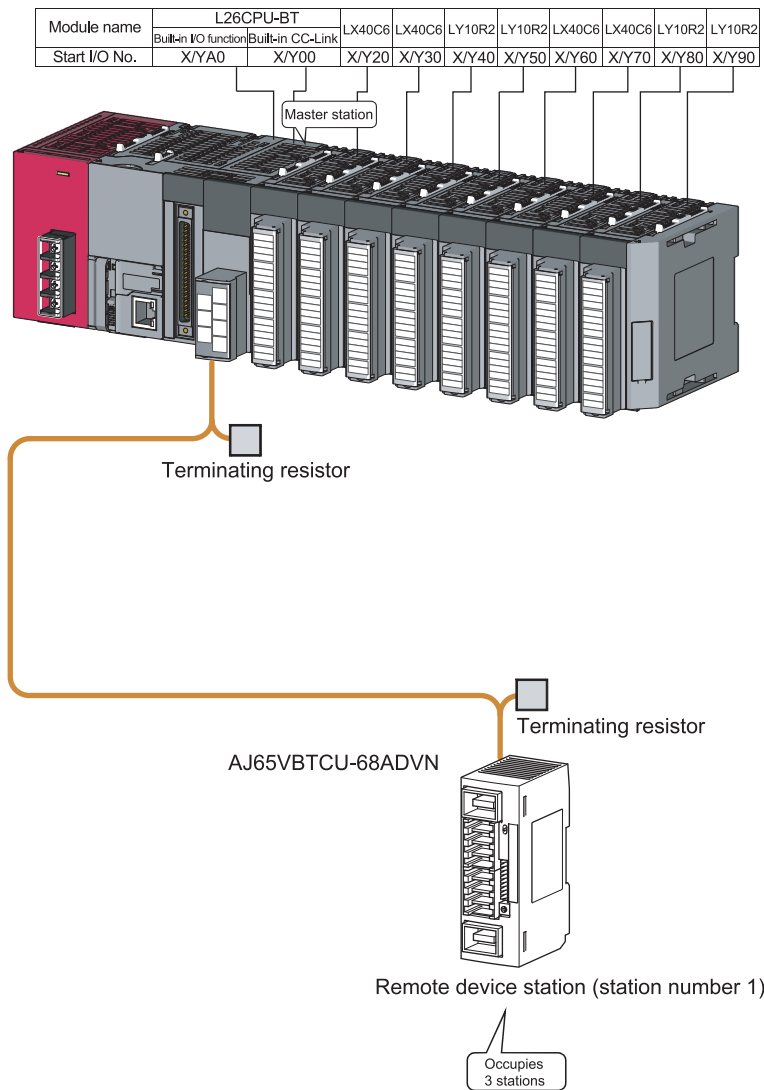

11.1 When Remote Net Ver.1 Mode is Used  
11.1.1 Configuring a system

## (1) Setting the remote device station

Settings of the remote device station switches are shown below:

For more detailed information about the settings, refer to the User's Manual for the remote device station.

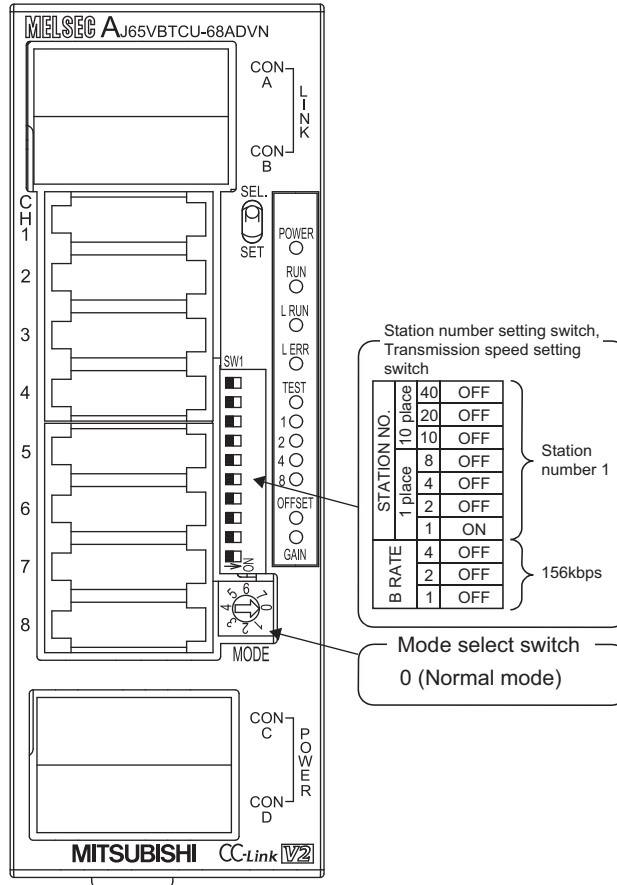



## 11.1.2 Parameter setting

### (1) Setting the network parameters and automatic refresh parameters of the master station

Set the network parameters and automatic refresh parameters as follows.

Refer to Page 252, Section 11.1.2 (2) for the operation setting. Refer to Page 252, Section 11.1.2 (3) for the station information setting.

Refer to Page 253, Section 11.1.2 (4) for the remote device station initial setting.

	1	
Start I/O No.	0000	
Operation Setting	Operation Setting	← Refer to Section 11.1.2 (2).
Type	Master Station	
Station No.	0	
Master Station Data Link Type	PLC Parameter Auto Start	
Mode	Remote Net(Ver.1 Mode)	
Transmission Speed	156kbps	
Total Module Connected	1	
Remote Input(RX)	X1000	
Remote Output(RY)	Y1000	
Remote Register(RWr)	W0	
Remote Register(RWw)	W100	
Ver.2 Remote Input(RX)		
Ver.2 Remote Output(RY)		
Ver.2 Remote Register(RWr)		
Ver.2 Remote Register(RWw)		
Special Relay(SB)	S80	
Special Register(SW)	SW0	
Retry Count	3	
Automatic Reconnection Station Count	1	
Standby Master Station No.		
PLC Down Select	Stop	
Scan Mode Setting	Asynchronous	
Delay Time Setting	0	
Station Information Setting	Station Information	← Refer to Section 11.1.2 (3).
Remote Device Station Initial Setting	Initial Setting	← Refer to Section 11.1.2 (4).
Interrupt Setting	Interrupt Setting	

#### Point

- Do not set the same refresh devices as the following.
  - Refresh parameters of modules on the network
  - I/O numbers used for I/O modules and an intelligent function module
  - Auto refresh settings of an intelligent function module
- To set X or Y as a refresh device, set a number later than the I/O numbers used for I/O modules and an intelligent function module.

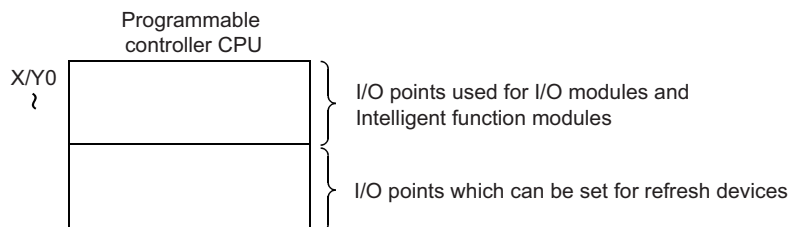

## (2) Operation setting

Set the operation settings as follows.

## (3) Station information setting

Set parameters as follows.

Station No.	Station Type	Expanded Cyclic Setting	Exclusive Count	Remote Station Points	Reserve/Invalid Station Select	Intelligent Buffer Select(Word)		
						Send	Receive	Automatic
1 / 1	Remote Device Station	Single	Exclusive Station 3	96 Points	No Setting			

"Intelligent Device Station" of "Station Type" includes local station and standby master station.

## (4) Remote device station initial setting

### (a) Setting the target station number

Set the target station for which the initial setting is performed.

#### 1. Setting the target station number

Set the target station No. to "1".

	Target Station No.	No. of Registered Procedures		Target Station No.	No. of Registered Procedures	
1	1	0	Regist Procedure	9		Regist Procedure
2			Regist Procedure	10		Regist Procedure
3			Regist Procedure	11		Regist Procedure
4			Regist Procedure	12		Regist Procedure
5			Regist Procedure	13		Regist Procedure
6			Regist Procedure	14		Regist Procedure
7			Regist Procedure	15		Regist Procedure
8			Regist Procedure	16		Regist Procedure

Clear      Check      End      Cancel

#### 2. Selecting the Regist Procedure

Click the "Regist Procedure" of the target station number "1".

### (b) Setting the regist procedure registration

Set the conditions and details of the remote device station settings.

For more detailed information about the settings, refer to the User's Manual for the remote device station.

In this section, AJ65VBTCU-68ADV is used as an example for the Regist procedure registration.

The details to be set are as follows:

- Set channels 1 and 2 to A-D conversion enable (the first condition).
- Set the Input range of channel 1 to 0 - 5V, and channel 2 to User range setting 1 (the second condition).
- Set channel 1 to Sampling processing, and specify channel 2 as Average processing and set it to Number of times (the third condition).
- Set channel 2 Average number of times to 16 times (the fourth condition).
- Turn the Initial data processing completed flag to ON (the fifth condition).
- Turn the Initial data setting request flag to ON (the sixth condition).
- Turn the Initial data processing completed flag to OFF (the seventh condition).
- Turn the Initial data setting request flag to OFF (the eighth condition).

Set parameters as follows.

Remote Device Station Initial Setting Procedure Registration Module 1 Target S...

Input Format: HEX.

Execute Flag	Operational Condition	Executorial Condition			Details of Execution		
		Condition Device	Device No.	Execute Condition	Write Device	Device No.	Write Data
Execute	Set New	RX	18	ON	RWw	00	0003
Execute	Same as Prev.Set	RX	18	ON	RWw	01	0031
Execute	Same as Prev.Set	RX	18	ON	RWw	03	0200
Execute	Same as Prev.Set	RX	18	ON	RWw	05	0010
Execute	Same as Prev.Set	RX	18	ON	RY	18	ON
Execute	Same as Prev.Set	RX	18	ON	RY	19	ON
Execute	Set New	RX	18	OFF	RY	18	OFF
Execute	Set New	RX	19	ON	RY	19	OFF

**Point**

The initial settings registered by using GX Works2 can be reflected to the remote device station by writing the settings to the CPU module and turning on the remote device station initialization procedure registration instruction (SB000D). (Refer to  Page 169, Section 8.3.1 (4))

## 11.1.3 Creating a program

This section shows a program used to control remote device stations.

The following diagrams show the relationships of the remote input/output and remote registers between the programmable controller CPU devices and the remote device station.

The shaded areas indicate the devices that are actually used.

For detailed information about each remote device station, refer to the User's Manual for each module.

[Remote input (RX) and remote output (RY)]

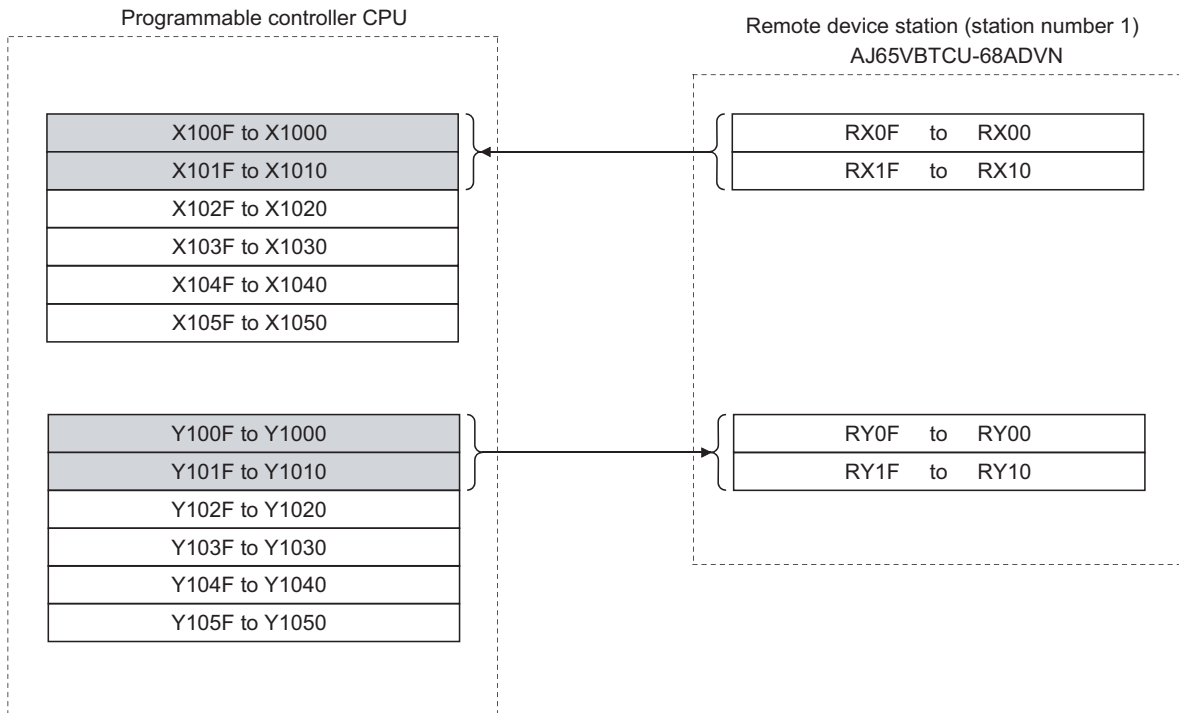

[Remote registers (RWw and RWr)]

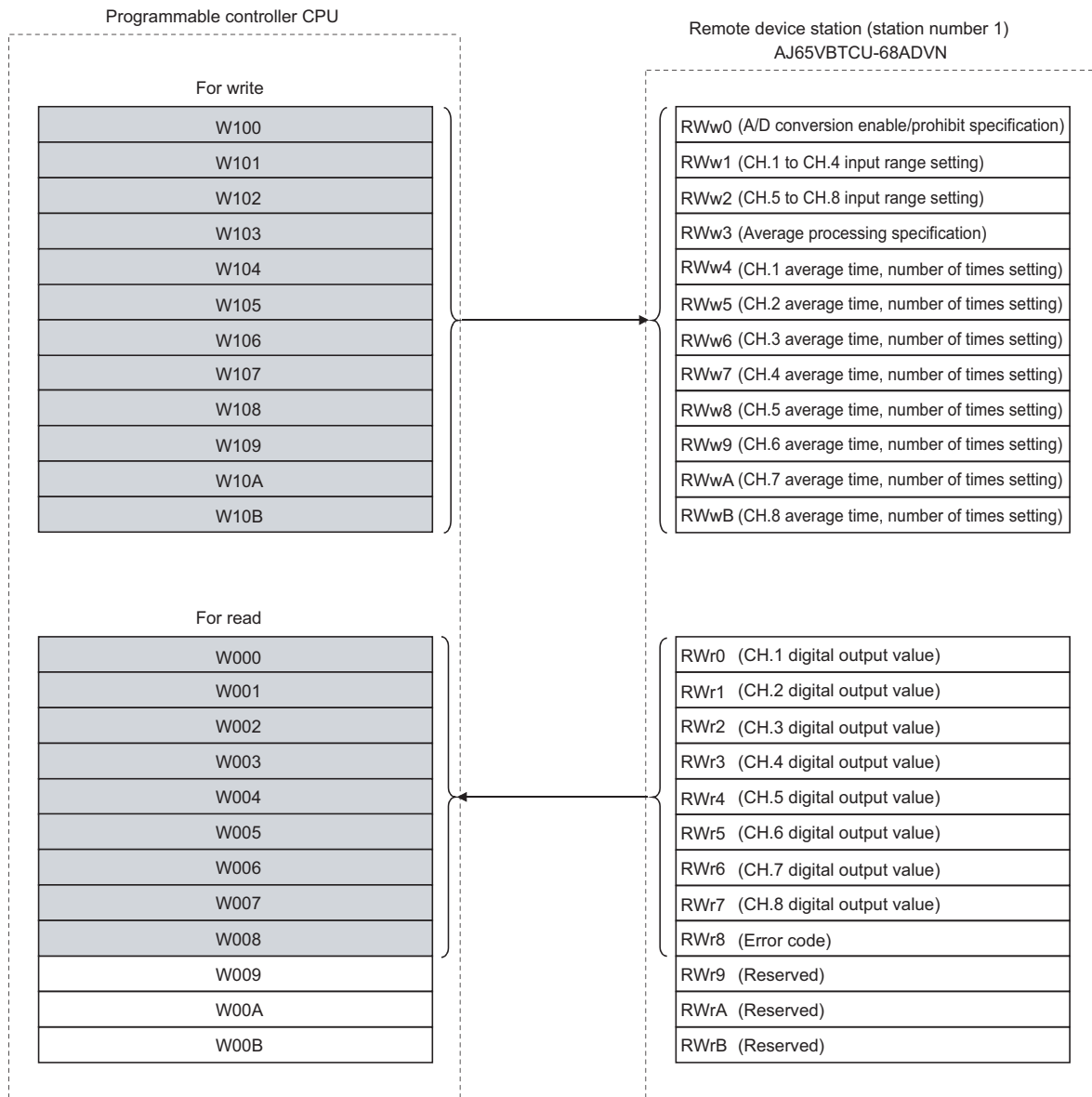

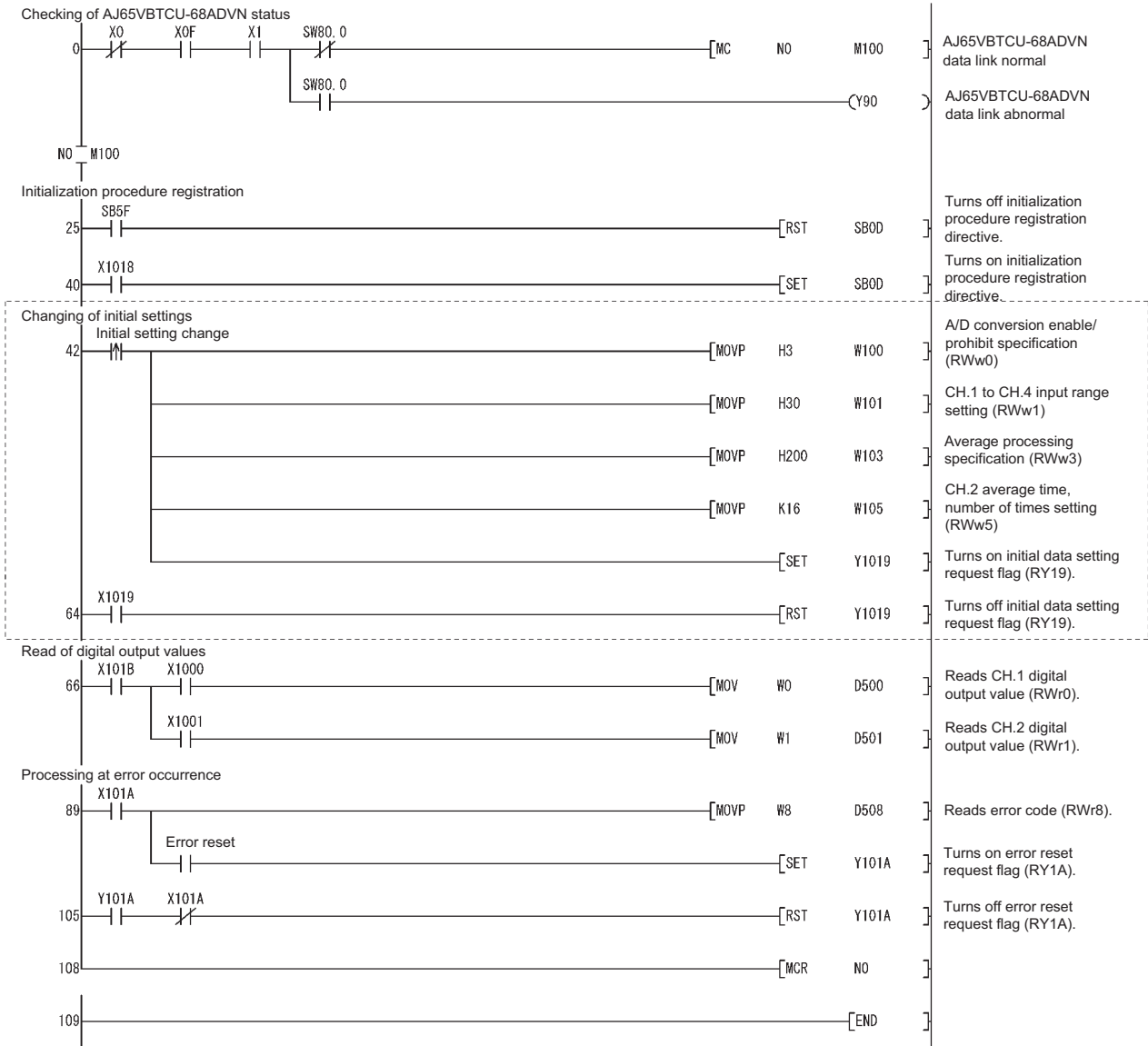

The program enclosed by the dotted line is necessary only when the initial settings are changed.

11.1 When Remote Net Ver.1 Mode is Used  
11.1.3 Creating a program

# 11.1.4 Performing the data link

Turn on the remote device station first, and then the master station to start the data link.

## (1) Confirming the operation with the LED indicators

The following diagram shows the LED status of the master station and the remote device station when the data link is being performed normally.

### (a) LED indication of the master station

Make sure that the LEDs are as follows:

■ : On    □ : Off

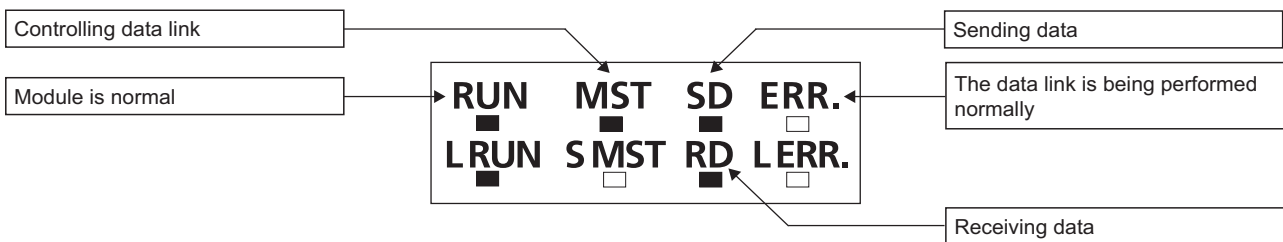

### (b) LED indication of the remote device station

Make sure that the LEDs are as follows:

● : On    ○ : Off

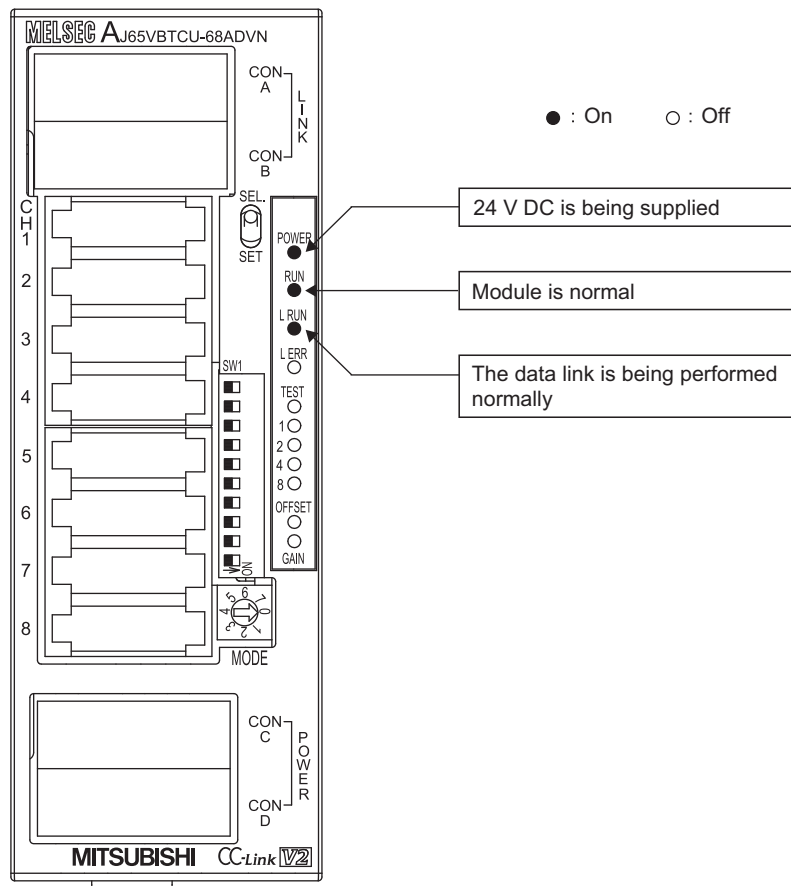



## (2) Confirming the operation with the program

Using the program, confirm that the data link is being performed normally.

- 1) Change the voltage input to the AJ65VBTCU-68ADV and confirm that the converted digital value also changes accordingly.

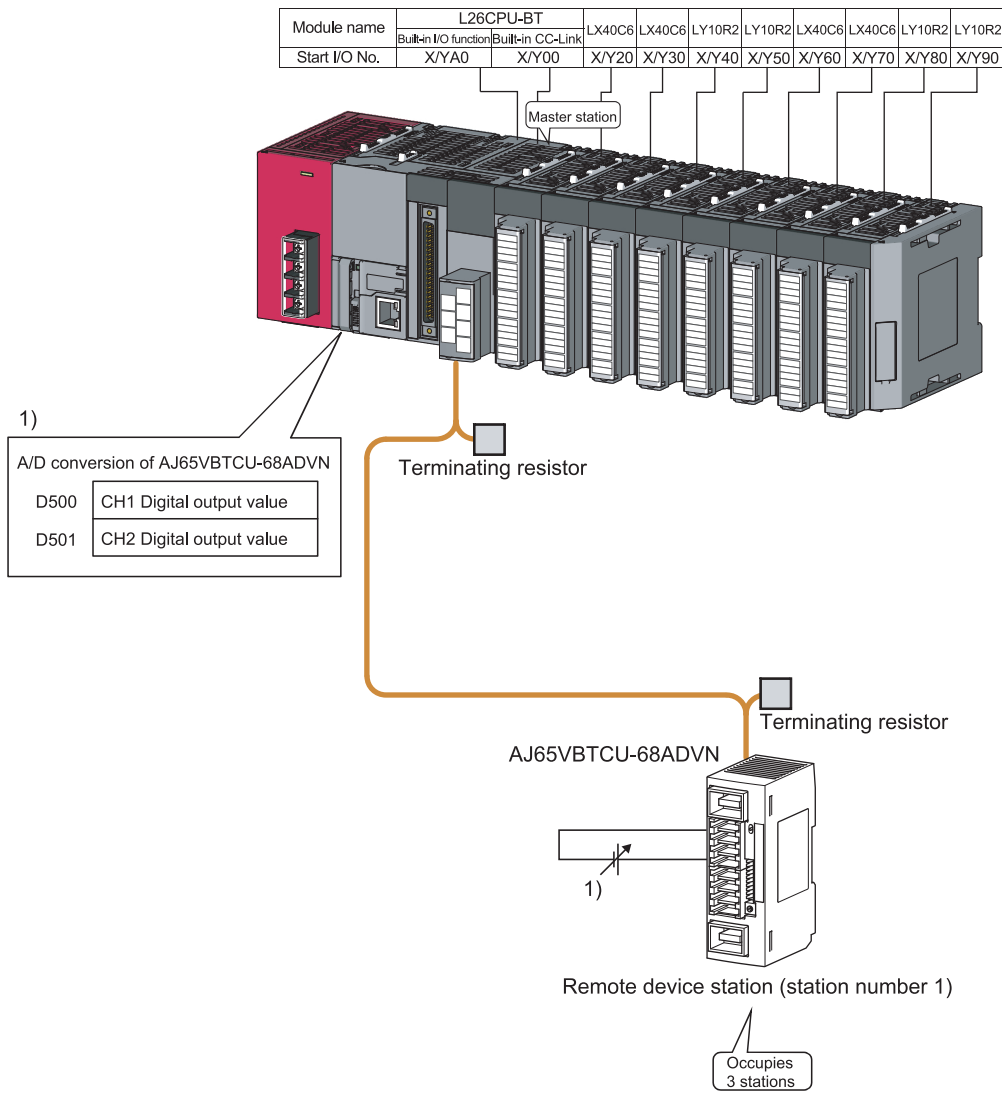

# 11.2 When Remote Net Ver.2 Mode is Used

## 11.2.1 Configuring a system

As shown below, a system where one ver.1 compatible remote device station and one ver.2 compatible remote device station are connected is used as an example.

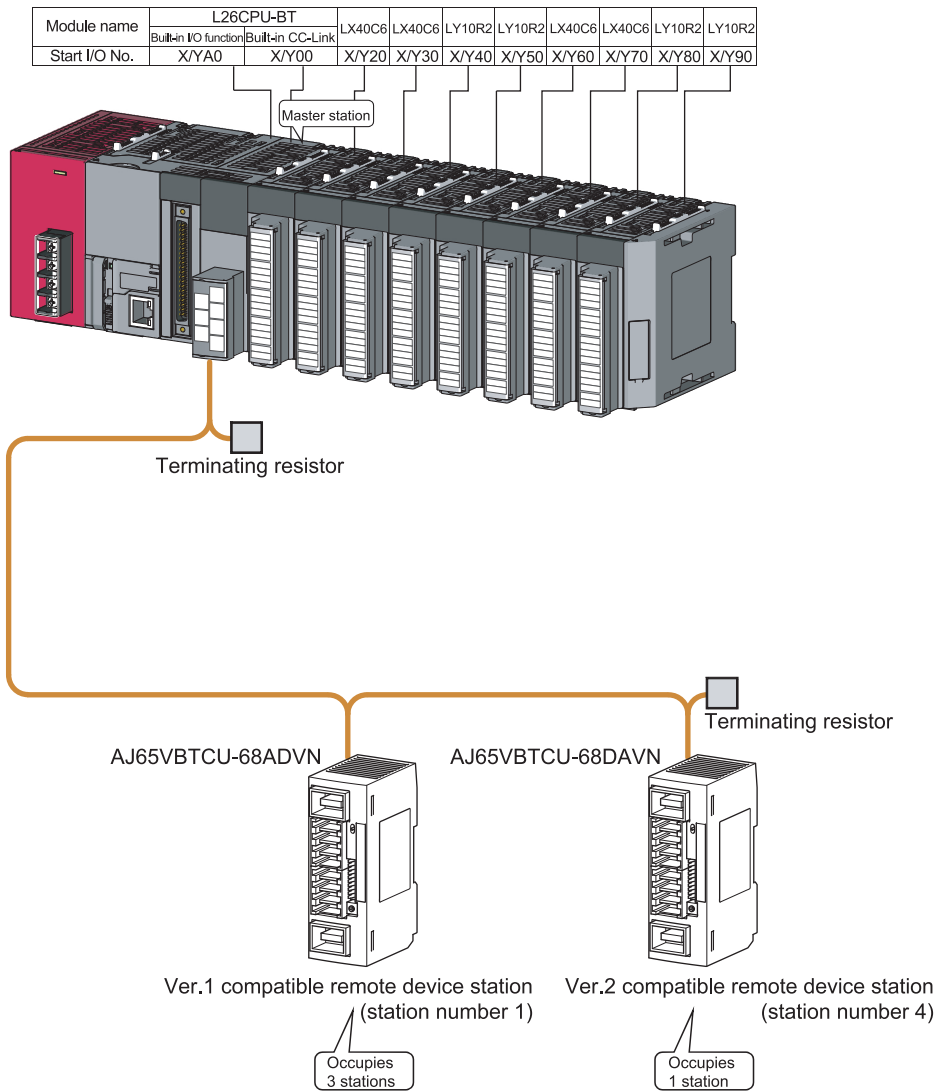

### (1) Setting the remote device station

Settings of the remote device station switches are shown below:

For more detailed information about the settings, refer to the User's Manual for the remote device station.

Setting of AJ65VBTCU-68ADVN

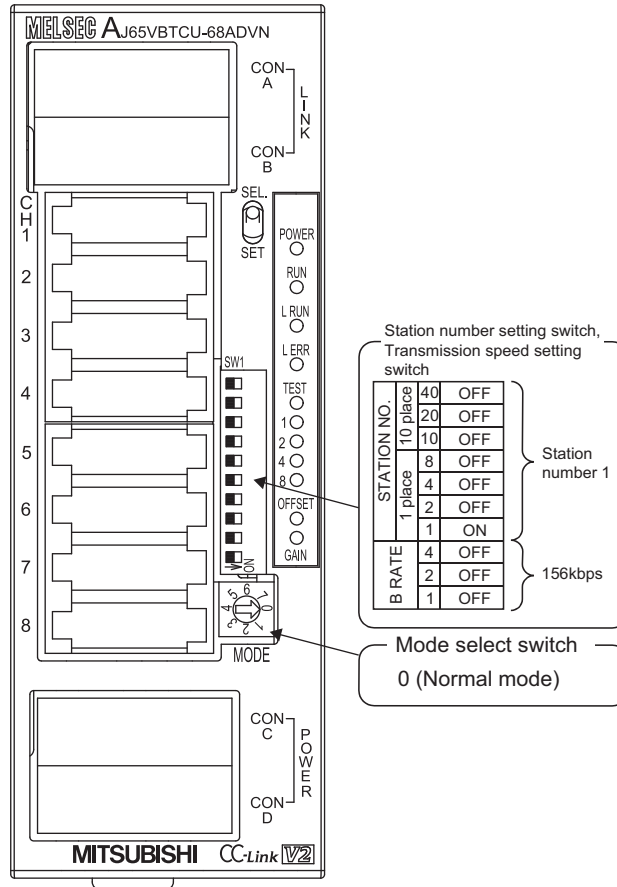

11.2 When Remote Net Ver.2 Mode is Used  
11.2.1 Configuring a system

Setting of AJ65VBTCU-68DAVN

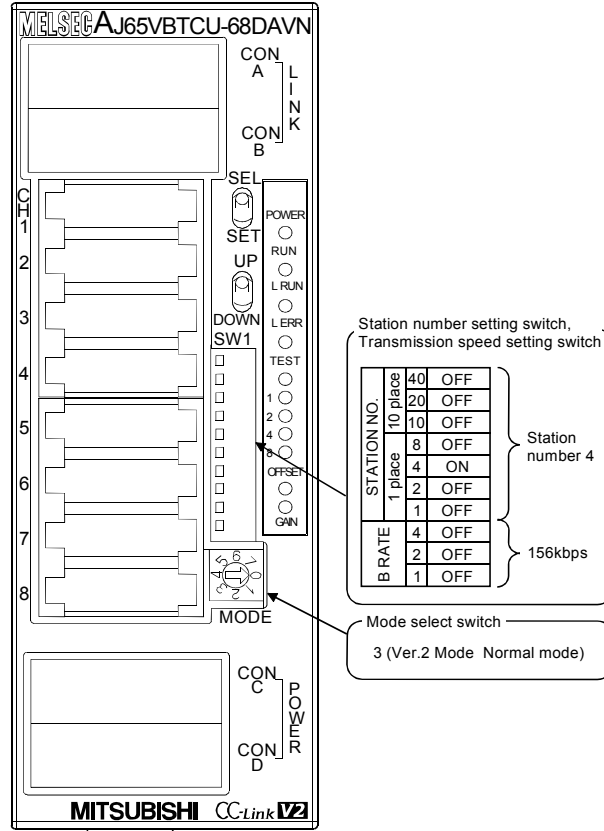

Setting of AJ65VBTCU-68DAVN



## 11.2.2 Parameter setting

### (1) Setting the network parameters and automatic refresh parameters of the master station

Set the network parameters and automatic refresh parameters as follows.

Refer to  Page 264, Section 11.2.2 (2) for the operation setting. Refer to  Page 264, Section 11.2.2 (3) for the station information setting.

Refer to  Page 265, Section 11.2.2 (4) for the remote device station initial setting.

	1	
Start I/O No.	0000	
Operation Setting	Operation Setting	← Refer to Section 11.2.2 (2).
Type	Master Station	
Station No.	0	
Master Station Data Link Type	PLC Parameter Auto Start	
Mode	Remote Net(Ver.2 Mode)	
Transmission Speed	156kbps	
Total Module Connected	2	
Remote Input(RX)	X1000	
Remote Output(RY)	Y1000	
Remote Register(RWr)	W0	
Remote Register(RWw)	W1000	
Ver.2 Remote Input(RX)		
Ver.2 Remote Output(RY)		
Ver.2 Remote Register(RWr)		
Ver.2 Remote Register(RWw)		
Special Relay(SB)	S80	
Special Register(SW)	SW0	
Retry Count	3	
Automatic Reconnection Station Count	1	
Standby Master Station No.		
PLC Down Select	Stop	
Scan Mode Setting	Asynchronous	
Delay Time Setting	0	
Station Information Setting	Station Information	← Refer to Section 11.2.2 (3).
Remote Device Station Initial Setting	Initial Setting	← Refer to Section 11.2.2 (4).
Interrupt Setting	Interrupt Setting	

### Point

- Do not set the same refresh devices as the following.
  - Refresh parameters of modules on the network
  - I/O numbers used for I/O modules and an intelligent function module
  - Auto refresh settings of an intelligent function module
- To set X or Y as a refresh device, set a number later than the I/O numbers used for I/O modules and an intelligent function module.

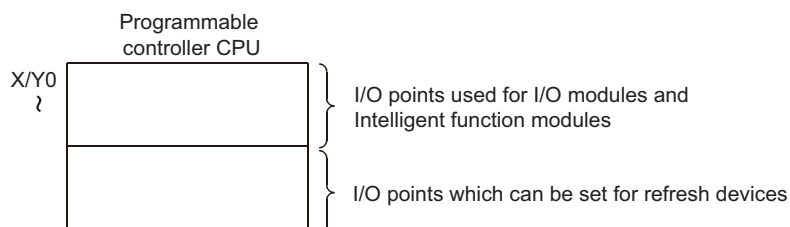

## (2) Operation setting

Set the operation setting as follows.

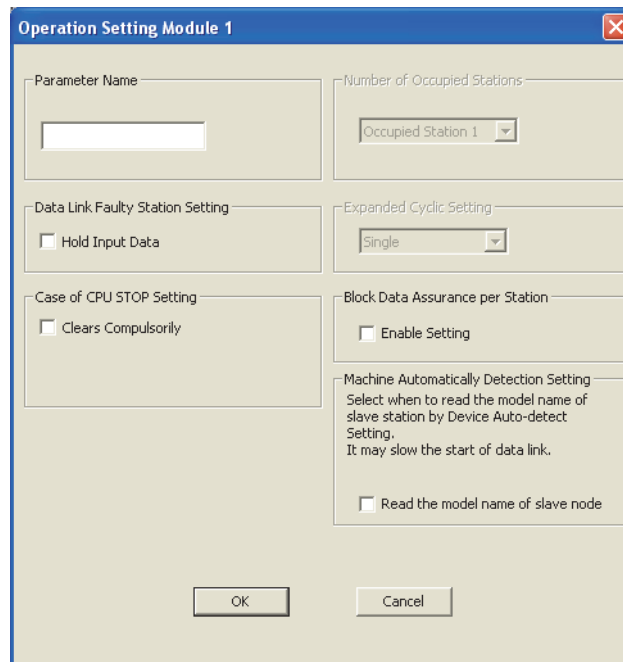

The 'Operation Setting Module 1' dialog box contains the following settings:

- Parameter Name:** An empty text input field.
- Number of Occupied Stations:** A dropdown menu set to 'Occupied Station 1'.
- Data Link Faulty Station Setting:** A checkbox for 'Hold Input Data' which is unchecked.
- Expanded Cyclic Setting:** A dropdown menu set to 'Single'.
- Case of CPU STOP Setting:** A checkbox for 'Clears Compulsorily' which is unchecked.
- Block Data Assurance per Station:** A checkbox for 'Enable Setting' which is unchecked.
- Machine Automatically Detection Setting:** A checkbox for 'Read the model name of slave node' which is unchecked. Below this checkbox is the text: 'Select when to read the model name of slave station by Device Auto-detect Setting. It may slow the start of data link.'

Buttons at the bottom: OK, Cancel.

## (3) Station information setting

Set parameters as follows.

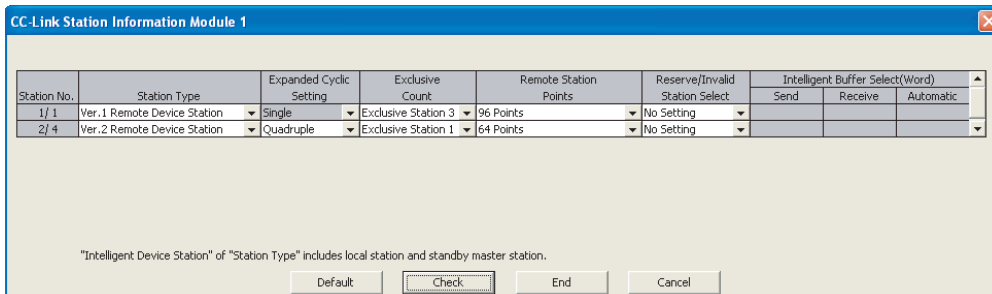

The 'CC-Link Station Information Module 1' dialog box displays a table of station information:

Station No.	Station Type	Expanded Cyclic Setting	Exclusive Count	Remote Station Points	Reserve/Invalid Station Select	Intelligent Buffer Select(Word)		
						Send	Receive	Automatic
1/1	Ver.1 Remote Device Station	Single	Exclusive Station 3	96 Points	No Setting			
2/4	Ver.2 Remote Device Station	Quadruple	Exclusive Station 1	64 Points	No Setting			

Below the table, a note states: "Intelligent Device Station" of "Station Type" includes local station and standby master station.

Buttons at the bottom: Default, Check, End, Cancel.

## (4) Initial setting of the remote device station

### (a) Setting the target station number

Set the target station for which the initial setting is performed.

#### 1. Setting the target station number

Set the target station numbers to "1" and "4".

	Target Station No.	No. of Registered Procedures		Target Station No.	No. of Registered Procedures	
1	1	0	Regist Procedure	9		Regist Procedure
2	4	0	Regist Procedure	10		Regist Procedure
3			Regist Procedure	11		Regist Procedure
4			Regist Procedure	12		Regist Procedure
5			Regist Procedure	13		Regist Procedure
6			Regist Procedure	14		Regist Procedure
7			Regist Procedure	15		Regist Procedure
8			Regist Procedure	16		Regist Procedure

Clear Check End Cancel

#### 2. Selecting the Regist Procedure

Click the "Regist Procedure" of the target station number "1".

### (b) Setting the regist procedure registration

Set the conditions and details of the remote device station settings.

For more detailed information about the settings, refer to the User's Manual for the remote device station.

In this section, AJ65VBTCU-68ADV and AJ65VBTCU-68DAVN are used as examples for the procedure registration.

#### 1. Procedure registration of AJ65VBTCU-68ADV

The details to be set are as follows:

- Set channels 1, 2 to A-D conversion enable (the first condition).
- Set the Input range of channel 1 to 0 - 5V, and channel 2 to User range setting 1 (the second condition).
- Set channel 1 to Sampling processing, and specify channel 2 as Average processing and set it to Number of times (the third condition).
- Set channel 2 Average number of times to 16 times (the fourth condition).
- Turn the Initial data processing completed flag to ON (the fifth condition).
- Turn the Initial data setting request flag to ON (the sixth condition).
- Turn the Initial data processing completed flag to OFF (the seventh condition).
- Turn the Initial data setting request flag to OFF (the eighth condition).

Set parameters as follows.

Execute Flag	Operational Condition	Executorial Condition			Details of Execution		
		Condition Device	Device No.	Execute Condition	Write Device	Device No.	Write Data
Execute	Set New	RX	18	ON	RWw	00	0003
Execute	Same as Prev.Set	RX	18	ON	RWw	01	0031
Execute	Same as Prev.Set	RX	18	ON	RWw	03	0200
Execute	Same as Prev.Set	RX	18	ON	RWw	05	0010
Execute	Same as Prev.Set	RX	18	ON	RY	18	ON
Execute	Same as Prev.Set	RX	18	ON	RY	19	ON
Execute	Set New	RX	18	OFF	RY	18	OFF
Execute	Set New	RX	19	ON	RY	19	OFF

## 2. Procedure registration of AJ65VBTCU-68DAVN

Click the "Regist Procedure" of the target station number "4".

The details to be set are as follows:

- Set channels 1 and 2 to Analog output enable. (the first condition)
- Set the output range of channel 1 to 0 - 5V, and channel 2 to User range setting 1. (the second condition)
- Set the HOLD/CLEAR setting of channels 1, 2 to CLEAR. (the third condition)
- Turn the Initial data processing completed flag to ON (the fourth condition).
- Turn the Initial data setting request flag to ON (the fifth condition).
- Turn the Initial data processing completed flag to OFF (the sixth condition).
- Turn the Initial data setting request flag to OFF (the seventh condition).

Set parameters as follows.

Execute Flag	Operational Condition	Executorial Condition			Details of Execution		
		Condition Device	Device No.	Execute Condition	Write Device	Device No.	Write Data
Execute	Set New	RX	18	ON	RWw	08	00FC
Execute	Same as Prev.Set	RX	18	ON	RWw	09	0031
Execute	Same as Prev.Set	RX	18	ON	RWw	0B	0000
Execute	Same as Prev.Set	RX	18	ON	RY	18	ON
Execute	Same as Prev.Set	RX	18	ON	RY	19	ON
Execute	Set New	RX	18	OFF	RY	18	ON
Execute	Set New	RX	19	ON	RY	19	ON



The initial settings registered by using GX Works2 can be reflected to the remote device station by writing the settings to the CPU module and turning on the remote device station initialization procedure registration instruction (SB000D). (Refer to

Page 169, Section 8.3.1 (4).)



## 11.2.3 Creating a program

This section shows a program used to control remote device stations.

The following diagrams show the relationships of the remote input/output and remote registers between the programmable controller CPU devices and the remote device stations.

The shaded areas indicate the devices that are actually used.

For detailed information about each remote device station, refer to the User's Manual for each module.

[Remote input (RX) and remote output (RY)]

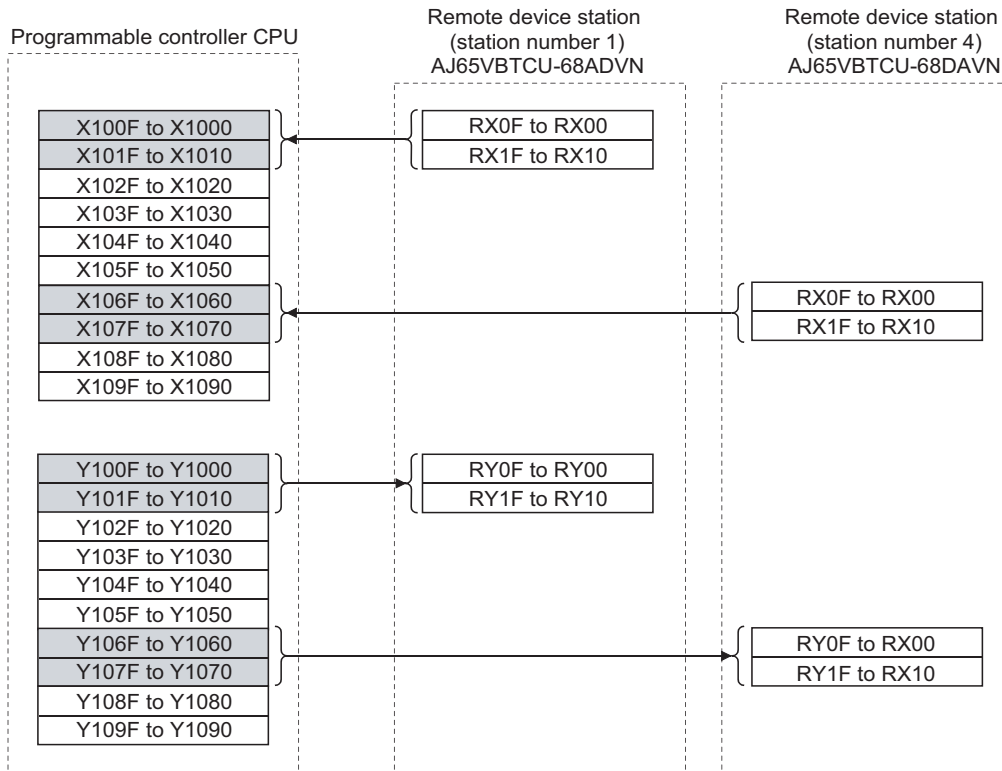

[Remote registers (RWw and RWr)]

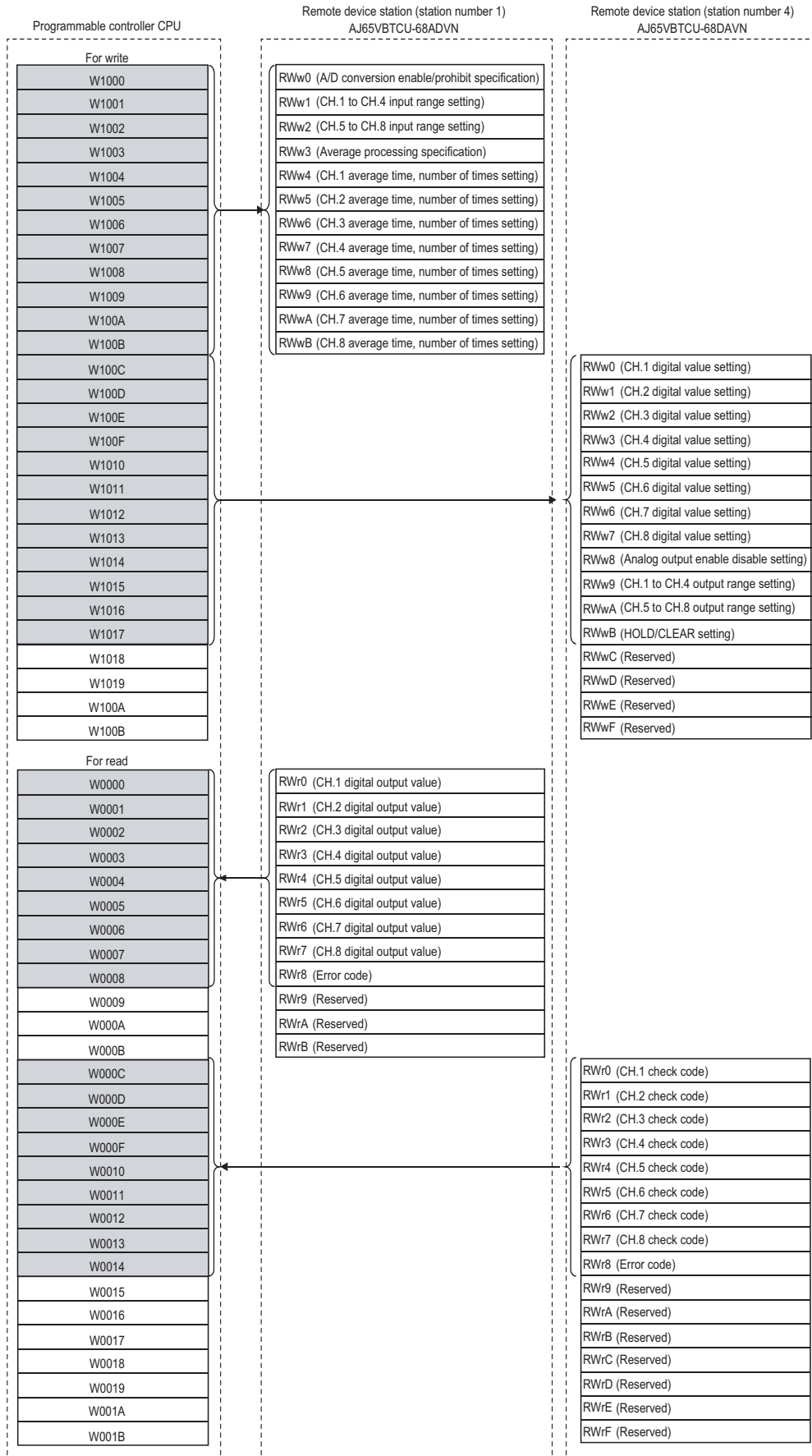

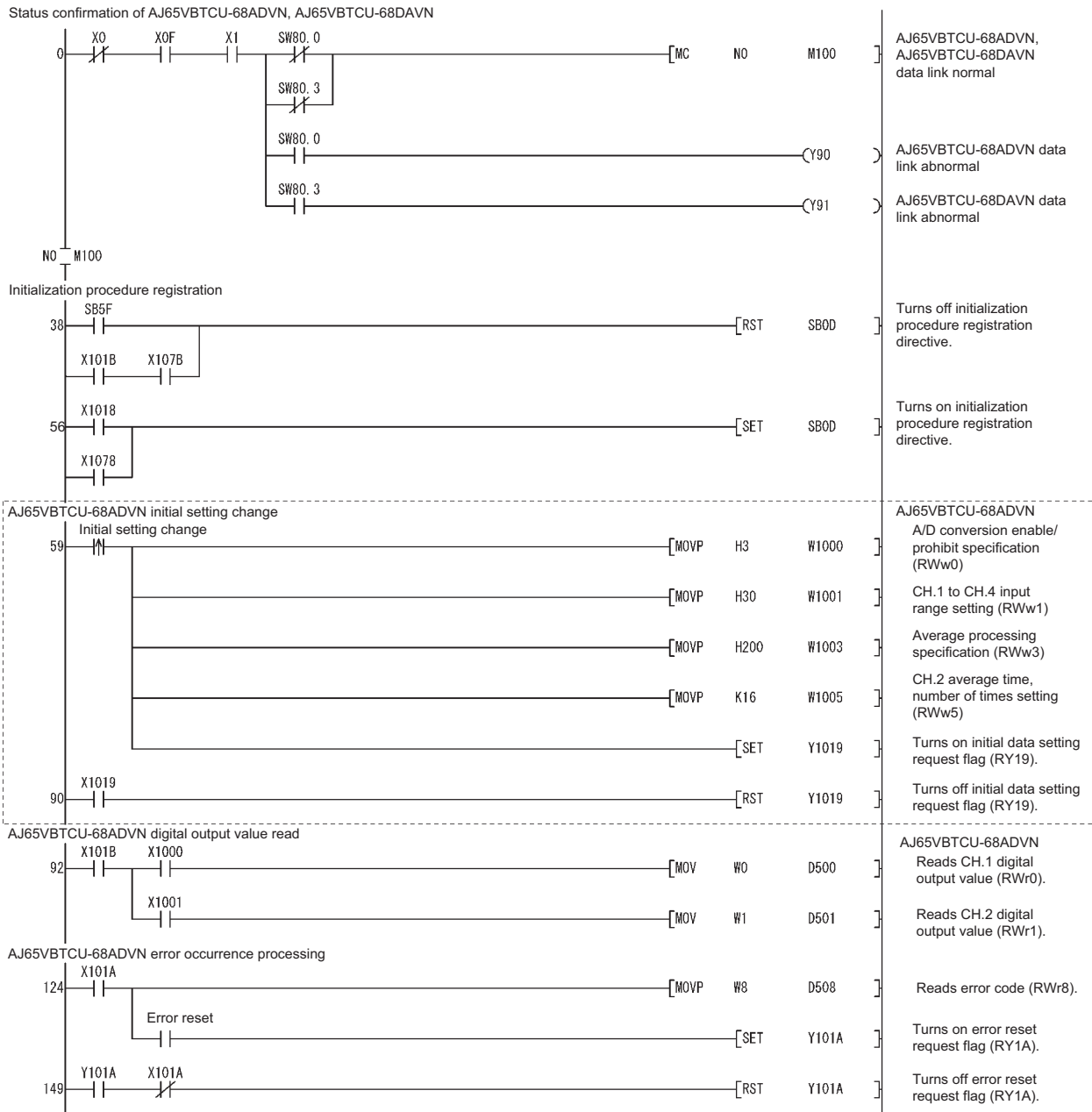

The program enclosed by the dotted line is necessary only when the initial settings are changed.

11.2 When Remote Net Ver.2 Mode is Used  
11.2.3 Creating a program

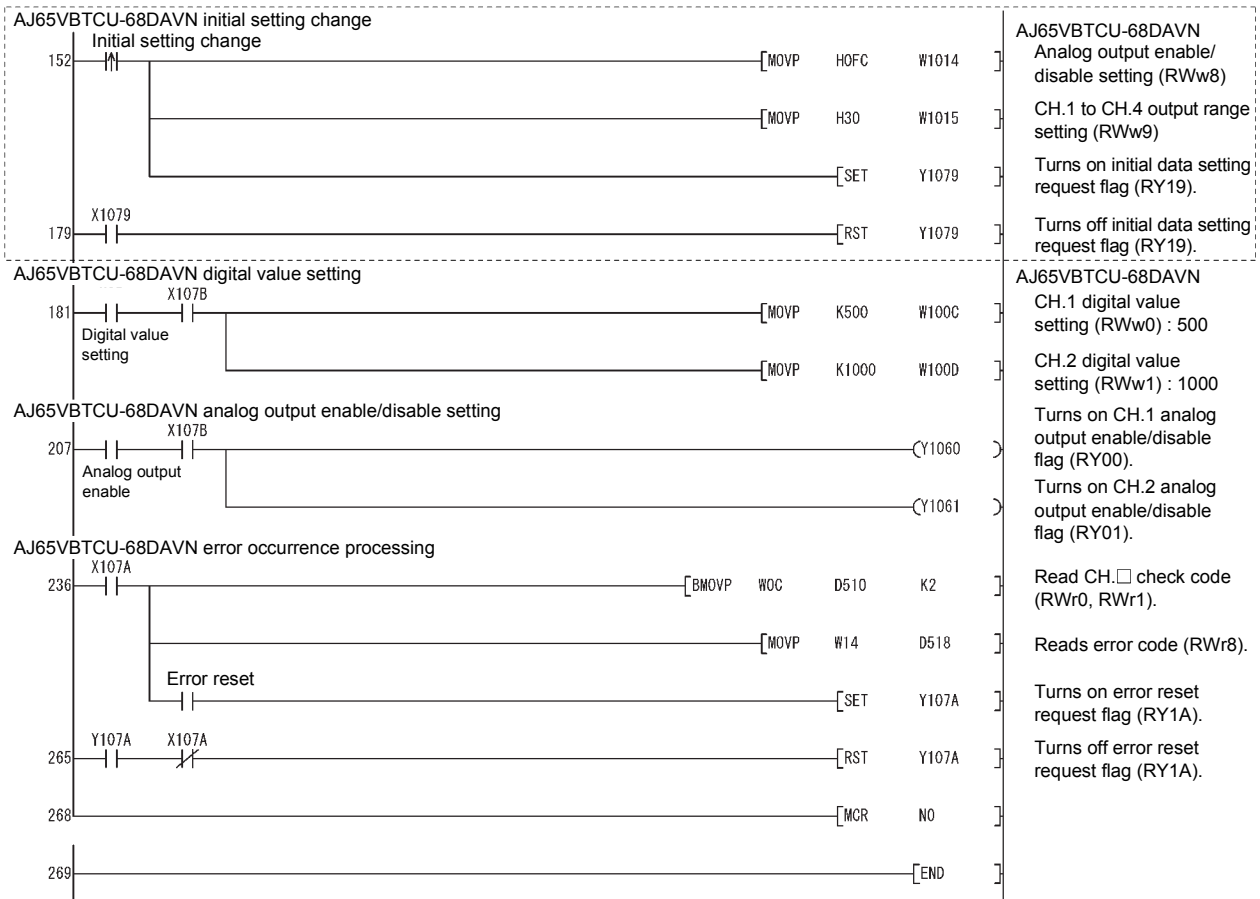

The program enclosed by the dotted line is necessary only when the initial settings are changed.

## 11.2.4 Performing the data link

Turn on the remote device stations first, and then the master station to start the data link.

### (1) Confirming the operation with the LED indicators

The following diagram shows the LED status of the master station and the remote device station when the data link is being performed normally.

#### (a) LED indication of the master station

Make sure that the LEDs are as follows:

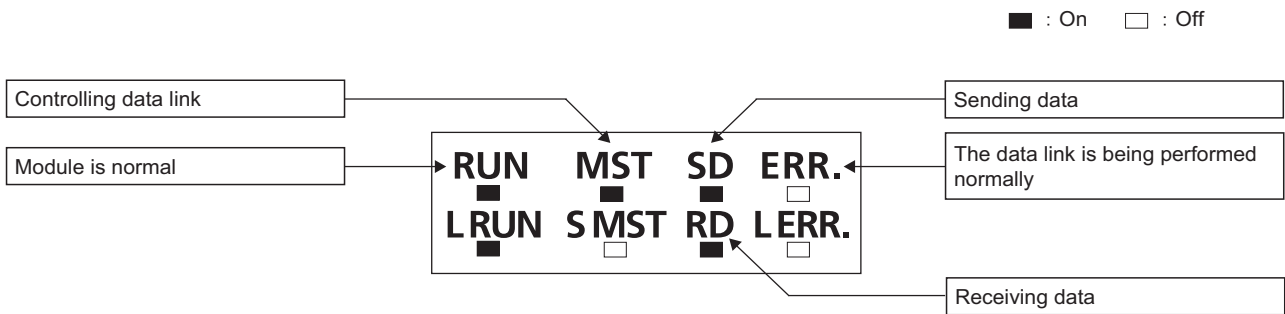

#### (b) LED indication of the remote device station

For both the AJ65VBTCU-68ADVN and AJ65VBTCU-68DAVN, confirm that the LEDs are as follows:

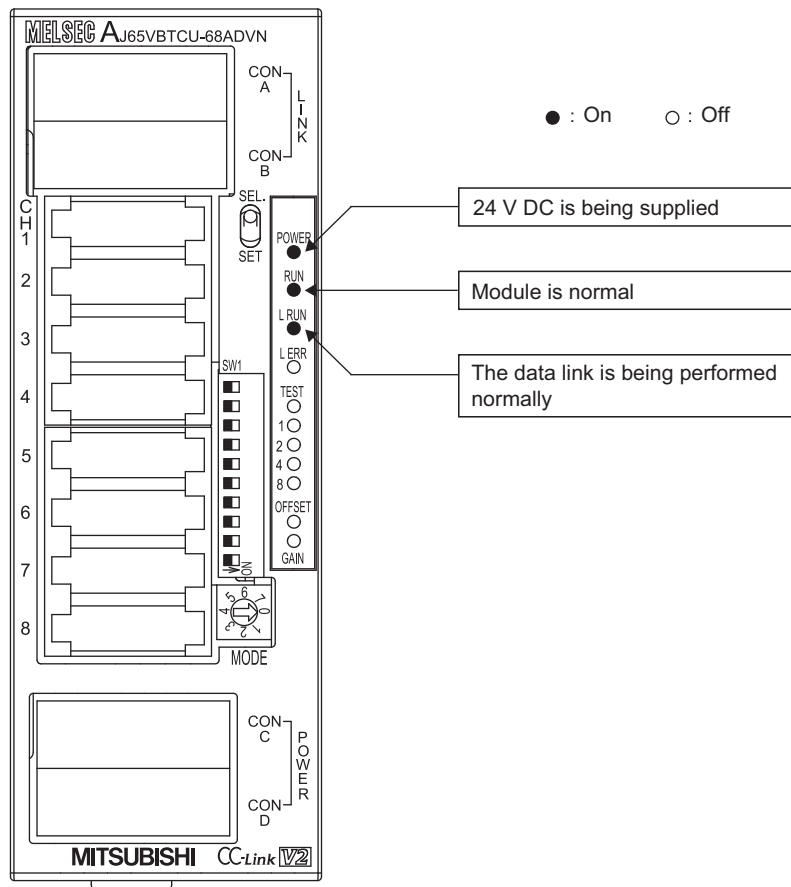

## (2) Confirming the operation with the program

Using the program, confirm that the data link is being performed normally.

- 1) Change the voltage input to the AJ65VBTCU-68ADV and confirm that the converted digital value also changes accordingly.
- 2) Set digital values to the AJ65VBTCU-68DAVN, and confirm that the voltages converted from digital to analog are output.

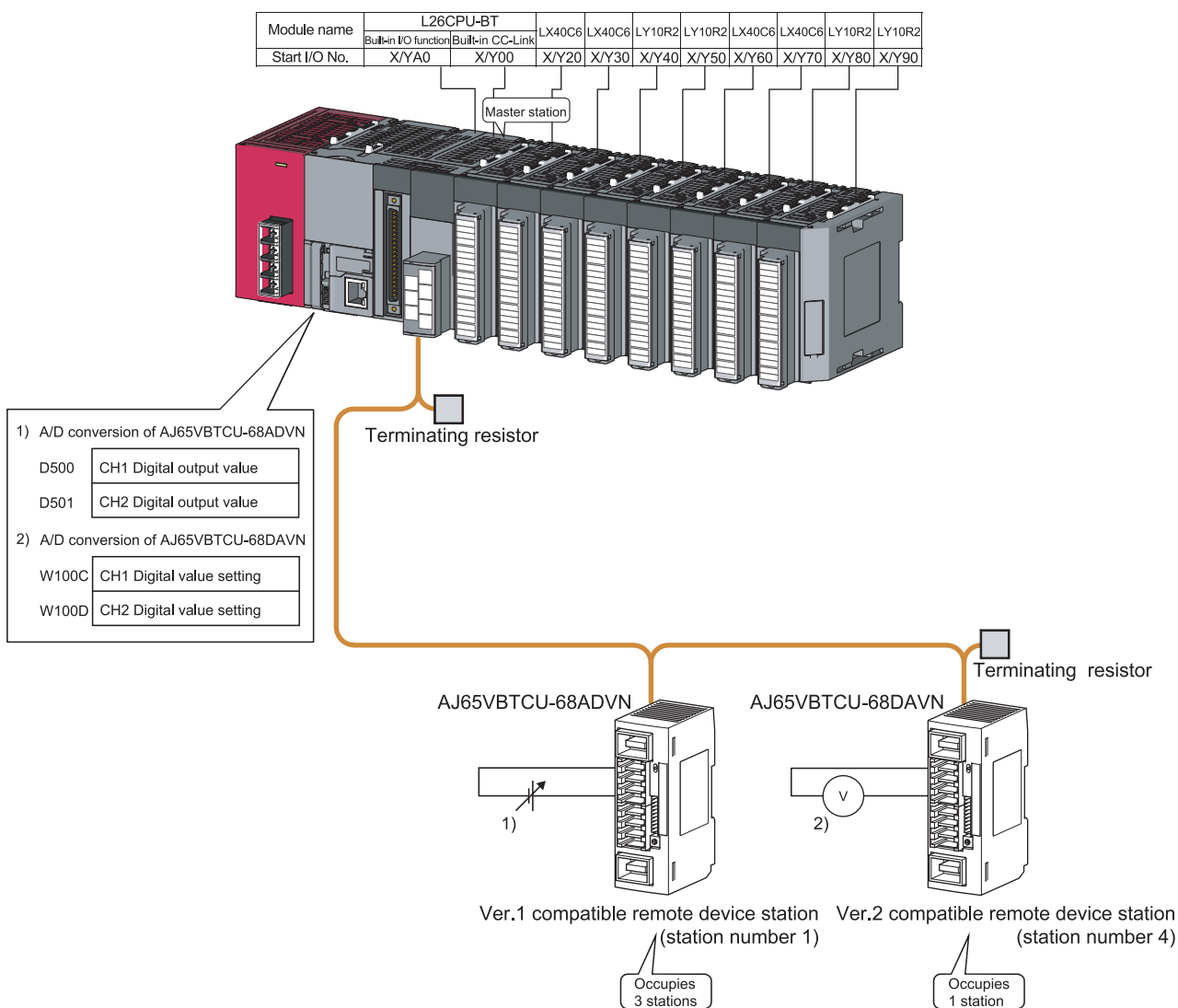

# 11.3 When Remote Net Additional Mode is Used

## 11.3.1 Configuring a system

As shown below, a system where one ver.1 compatible remote device station and one ver.2 compatible remote device station are connected is used as an example.

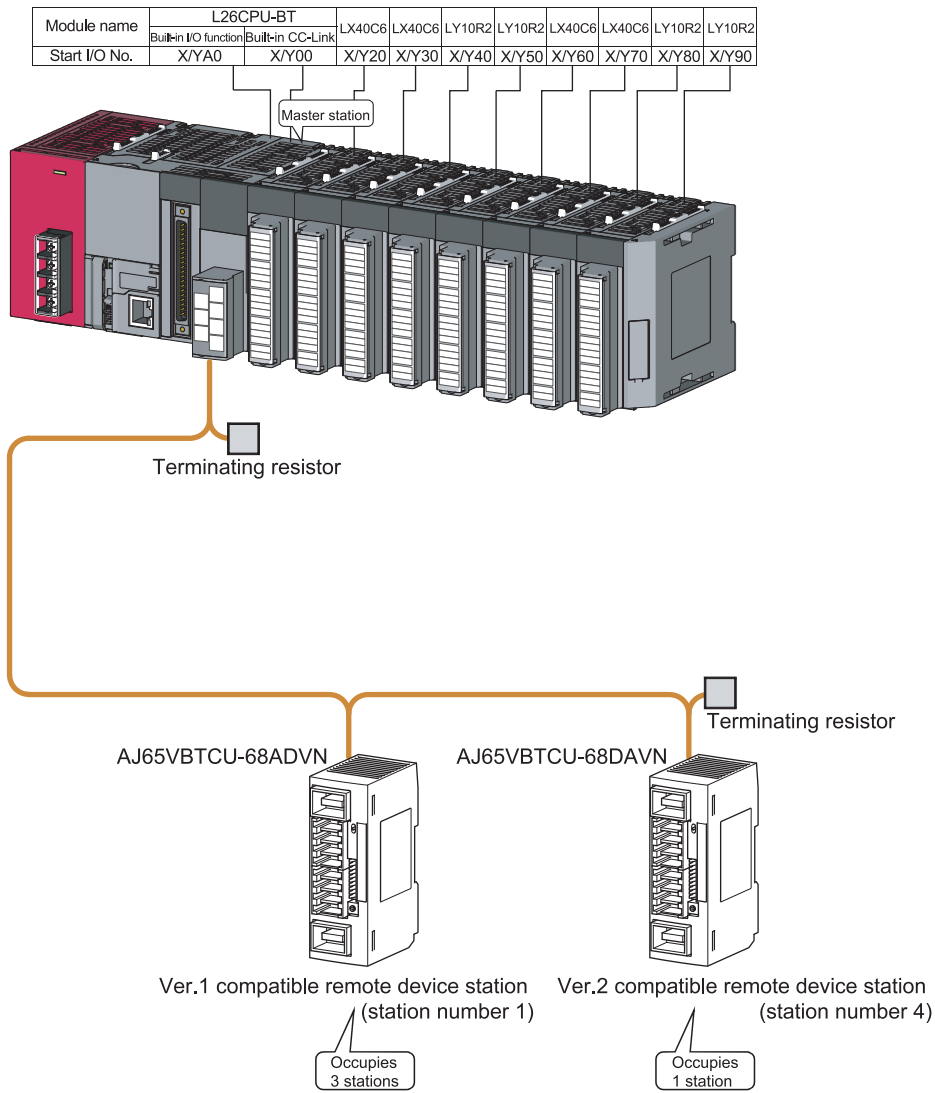

11.3 When Remote Net Additional Mode is Used  
11.3.1 Configuring a system

## (1) Setting the remote device station

Settings of the remote device station switches are shown below:

For more detailed information about the contents of the settings, refer to the User's Manual for the remote device station.

Setting of AJ65VBTCU-68ADV

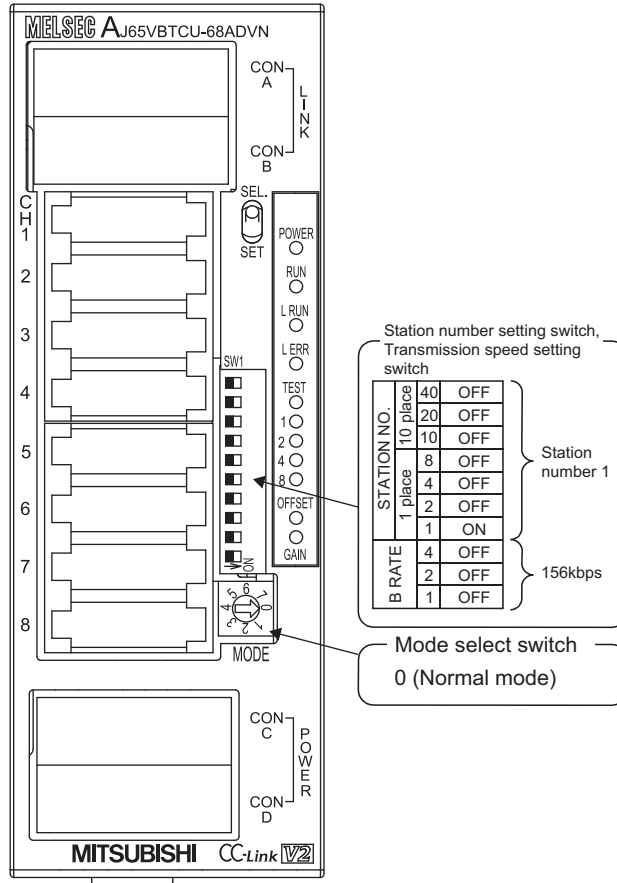



Setting of AJ65VBTCU-68DAVN

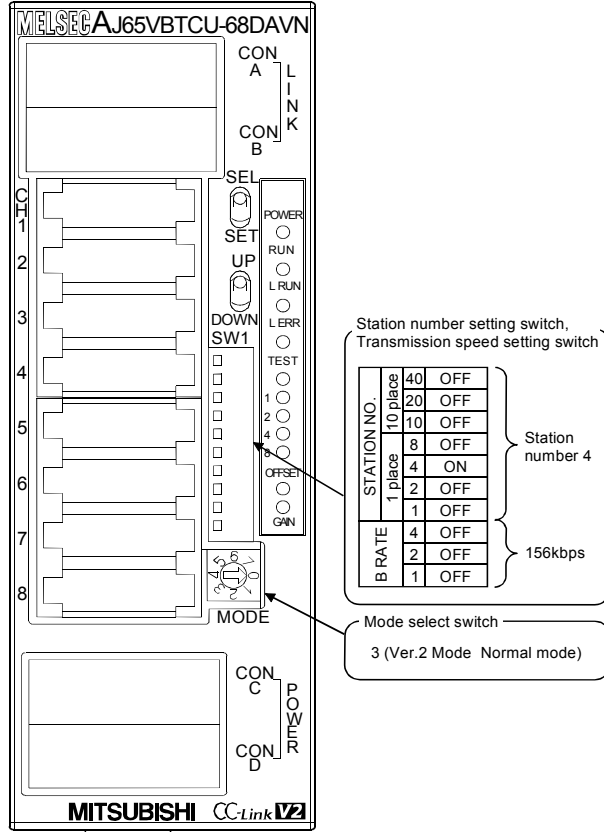

Setting of AJ65VBTCU-68DAVN



## 11.3.2 Parameter setting

### (1) Setting the network parameters and automatic refresh parameters of the master station

Set the network parameters and automatic refresh parameters as follows.

Refer to  Page 277, Section 11.3.2 (2) for the operation setting. Refer to  Page 277, Section 11.3.2 (3) for the station information setting.

Refer to  Page 278, Section 11.3.2 (4) for the remote device station initial setting.

	1	
Start I/O No.	0000	
Operation Setting	Operation Setting	← Refer to Section 11.3.2 (2).
Type	Master Station	
Station No.	0	
Master Station Data Link Type	PLC Parameter Auto Start	
Mode	Remote Net(Additional Mode)	
Transmission Speed	156kbps	
Total Module Connected	2	
Remote Input(RX)	X1000	
Remote Output(RY)	Y1000	
Remote Register(RWr)	W0	
Remote Register(RWw)	W100	
Ver.2 Remote Input(RX)	X1500	
Ver.2 Remote Output(RY)	Y1500	
Ver.2 Remote Register(RWr)	W1000	
Ver.2 Remote Register(RWw)	W1500	
Special Relay(SB)	SB0	
Special Register(SW)	SW0	
Retry Count	3	
Automatic Reconnection Station Count	1	
Standby Master Station No.		
PLC Down Select	Stop	
Scan Mode Setting	Asynchronous	
Delay Time Setting	0	
Station Information Setting	Station Information	← Refer to Section 11.3.2 (3).
Remote Device Station Initial Setting	Initial Setting	← Refer to Section 11.3.2 (4).
Interrupt Setting	Interrupt Setting	

### Point

- Do not set the same refresh devices as the following.
  - Refresh parameters of modules on the network
  - I/O numbers used for I/O modules and an intelligent function module
  - Auto refresh settings of an intelligent function module
- To set X or Y as a refresh device, set a number later than the I/O numbers used for I/O modules and an intelligent function module.

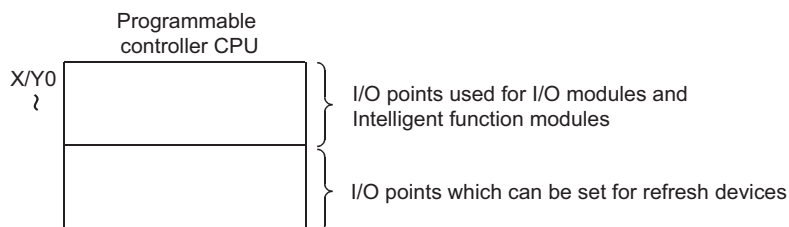

## (2) Operation setting

Set the operation setting as follows.

## (3) Station information setting

Set parameters as follows.

Station No.	Station Type	Expanded Cyclic Setting	Exclusive Count	Remote Station Points	Reserve/Invalid Station Select	Intelligent Buffer Select(Word)		
						Send	Receive	Automatic
1/1	Ver.1 Remote Device Station	Single	Exclusive Station 3	96 Points	No Setting			
2/4	Ver.2 Remote Device Station	Quadruple	Exclusive Station 1	64 Points	No Setting			

"Intelligent Device Station" of "Station Type" includes local station and standby master station.

Buttons: Default, Check, End, Cancel

#### (4) Initial setting of the remote device station

##### (a) Setting the target station number

Set the target station for which the initial setting is performed.

##### 1. Setting the target station number

Set the target station numbers to "1" and "4".

	Target Station No.	No. of Registered Procedures			Target Station No.	No. of Registered Procedures	
1	1	0	Regist Procedure	9			Regist Procedure
2	4	0	Regist Procedure	10			Regist Procedure
3			Regist Procedure	11			Regist Procedure
4			Regist Procedure	12			Regist Procedure
5			Regist Procedure	13			Regist Procedure
6			Regist Procedure	14			Regist Procedure
7			Regist Procedure	15			Regist Procedure
8			Regist Procedure	16			Regist Procedure

Clear Check End Cancel

##### 2. Selecting the Regist Procedure

Click the "Regist Procedure" of the target station number "1".

##### (b) Setting the regist procedure registration

Set the conditions and details of the remote device station settings.

For more detailed information about the settings, refer to the Remote Device Station User's Manual.

In this section, AJ65VBTCU-68ADV and AJ65VBTCU-68DAVN are used as examples for the procedure registration.

##### 1. Procedure registration of AJ65VBTCU-68ADV

The details to be set are as follows:

- Set channels 1 and 2 to A-D conversion enable (the first condition).
- Set the Input range of channel 1 to 0 - 5V, and channel 2 to User range setting 1 (the second condition).
- Set channel 1 to Sampling processing, and specify channel 2 as Average processing and set it to Number of times (the third condition).
- Set channel 2 Average number of times to 16 times (the fourth condition).
- Turn the Initial data processing completed flag to ON (the fifth condition).
- Turn the Initial data setting request flag to ON (the sixth condition).
- Turn the Initial data processing completed flag to OFF (the seventh condition).
- Turn the Initial data setting request flag to OFF (the eighth condition).

Set parameters as follows.

Execute Flag	Operational Condition	Executorial Condition			Details of Execution		
		Condition Device	Device No.	Execute Condition	Write Device	Device No.	Write Data
Execute	Set New	RX	18	ON	RWw	00	0003
Execute	Same as Prev.Set	RX	18	ON	RWw	01	0031
Execute	Same as Prev.Set	RX	18	ON	RWw	03	0200
Execute	Same as Prev.Set	RX	18	ON	RWw	05	0010
Execute	Same as Prev.Set	RX	18	ON	RY	18	ON
Execute	Same as Prev.Set	RX	18	ON	RY	19	ON
Execute	Set New	RX	18	OFF	RY	18	OFF
Execute	Set New	RX	19	ON	RY	19	OFF

**2. Procedure registration of AJ65VBTCU-68DAVN**

Click the "Regist Procedure" of the target station number "4".

The details to be set are as follows:

- Set channels 1 and 2 to Analog output enable. (the first condition)
- Set the output range of channel 1 to 0 - 5V, and channel 2 to User range setting 1. (the second condition)
- Set the HOLD/CLEAR setting of channels 1, 2 to CLEAR. (the third condition)
- Turn the Initial data processing completed flag to ON (the forth condition).
- Turn the Initial data setting request flag to ON (the fifth condition).
- Turn the Initial data processing completed flag to OFF (the sixth condition).
- Turn the Initial data setting request flag to OFF (the seventh condition).

Set parameters as follows.

Execute Flag	Operational Condition	Executorial Condition			Details of Execution		
		Condition Device	Device No.	Execute Condition	Write Device	Device No.	Write Data
Execute	Set New	RX	18	ON	RWw	08	00FC
Execute	Same as Prev.Set	RX	18	ON	RWw	09	0031
Execute	Same as Prev.Set	RX	18	ON	RWw	0B	0000
Execute	Same as Prev.Set	RX	18	ON	RY	18	ON
Execute	Same as Prev.Set	RX	18	ON	RY	19	ON
Execute	Set New	RX	18	OFF	RY	18	OFF
Execute	Set New	RX	19	ON	RY	19	OFF

**Point**

The initial settings registered by using GX Works2 can be reflected to the remote device station by writing the settings to the CPU module and turning on the remote device station initialization procedure registration instruction (SB000D). (Refer to Page 169, Section 8.3.1 (4).)

### 11.3.3 Creating a program

This section shows a program used to control the remote device stations.

The following diagrams show the relationships of the remote input/output and remote registers between the programmable controller CPU devices and the remote device station.

The shaded areas indicate the devices that are actually used.

For detailed information about each remote device station, refer to the User's Manual for each module.

[Remote input (RX) and remote output (RY)]

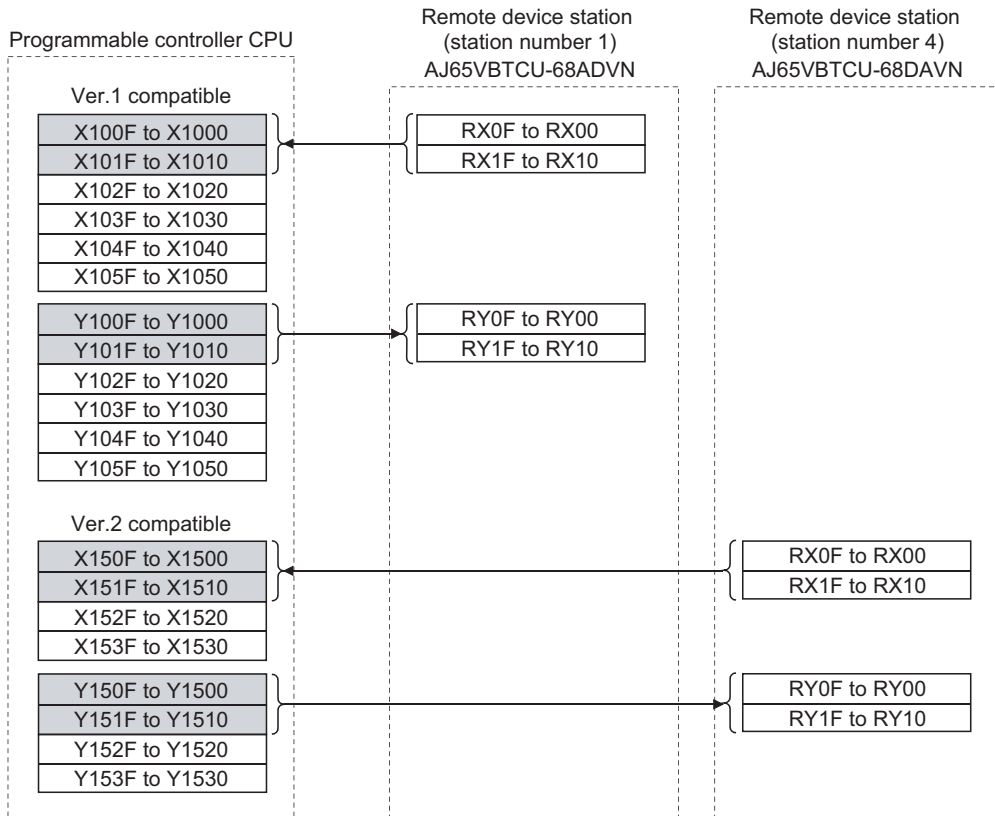

[Remote registers (RWw and RWr)]

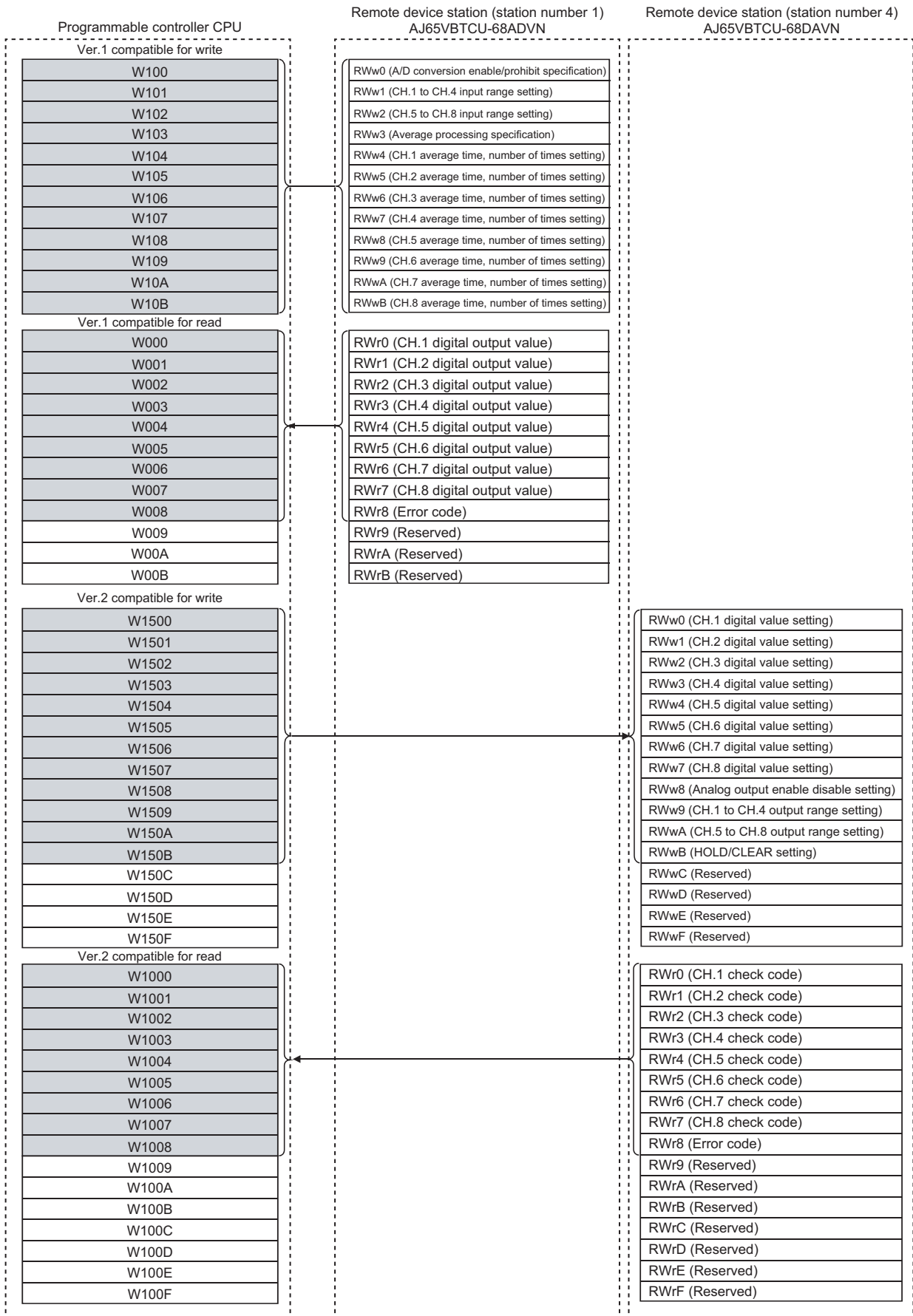

Status confirmation of AJ65VBTCU-68ADV, AJ65VBTCU-68DAVN

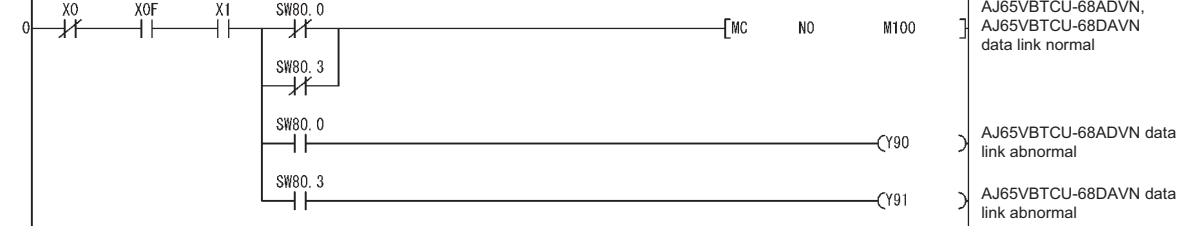

AJ65VBTCU-68ADV,  
AJ65VBTCU-68DAVN  
data link normal

AJ65VBTCU-68ADV data  
link abnormal

AJ65VBTCU-68DAVN data  
link abnormal

Initialization procedure registration

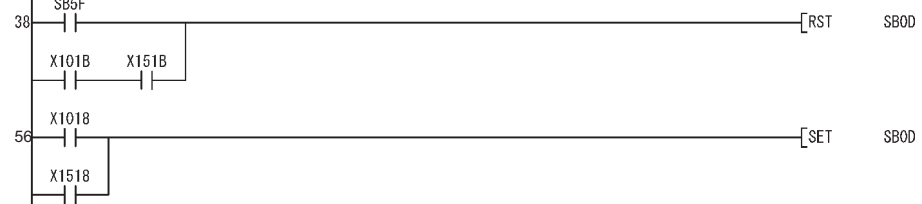

Turns off initialization  
procedure registration  
directive.

Turns on initialization  
procedure registration  
directive.

AJ65VBTCU-68ADV initial setting change



AJ65VBTCU-68ADV  
A/D conversion enable/  
prohibit specification  
(RWw0)

CH.1 to CH.4 input  
range setting (RWw1)

Average processing  
specification (RWw3)

CH.2 average time,  
number of times setting  
(RWw5)

Turns on initial data setting  
request flag (RY19).

Turns off initial data setting  
request flag (RY19).

AJ65VBTCU-68ADV digital output value read

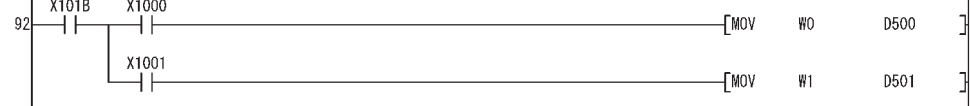

AJ65VBTCU-68ADV  
Reads CH.1 digital  
output value (RWr0).

Reads CH.2 digital  
output value (RWr1).

AJ65VBTCU-68ADV error occurrence processing

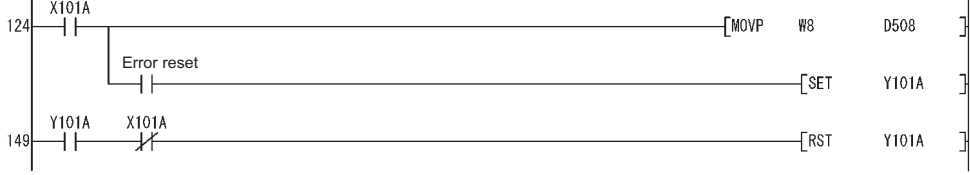

Reads error code (RWr8).

Turns on error reset  
request flag (RY1A).

Turns off error reset  
request flag (RY1A).

The program enclosed by the dotted line is necessary only when the initial settings are changed.



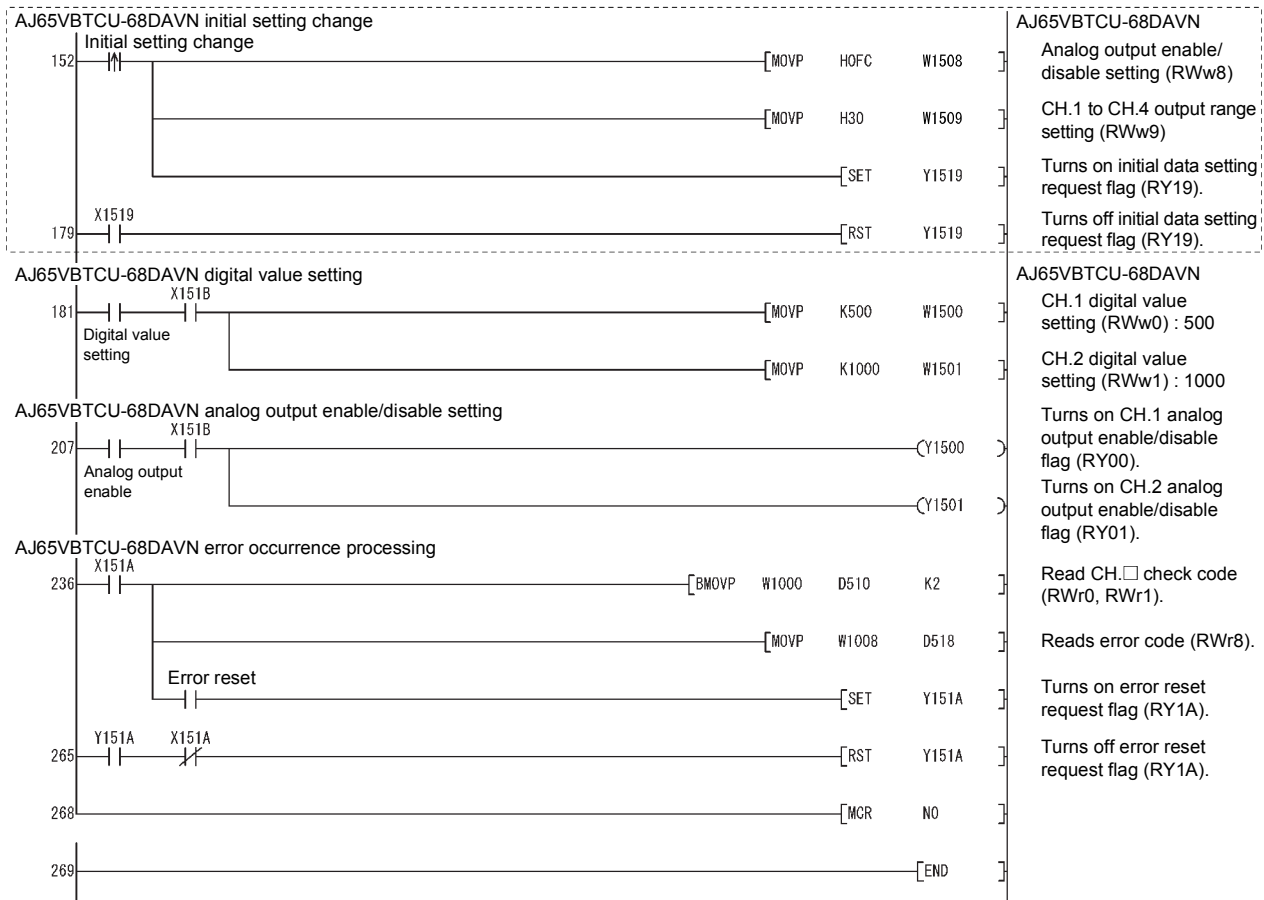

The program enclosed by the dotted line is necessary only when the initial settings are changed.

# 11.3.4 Performing the data link

Turn on the remote device stations first, and then the master station to start the data link.

## (1) Confirming the operation with the LED indicators

The following diagram shows the LED status of the master station and the remote device station when the data link is being performed normally.

### (a) LED indication of the master station

Make sure that the LEDs are as follows:

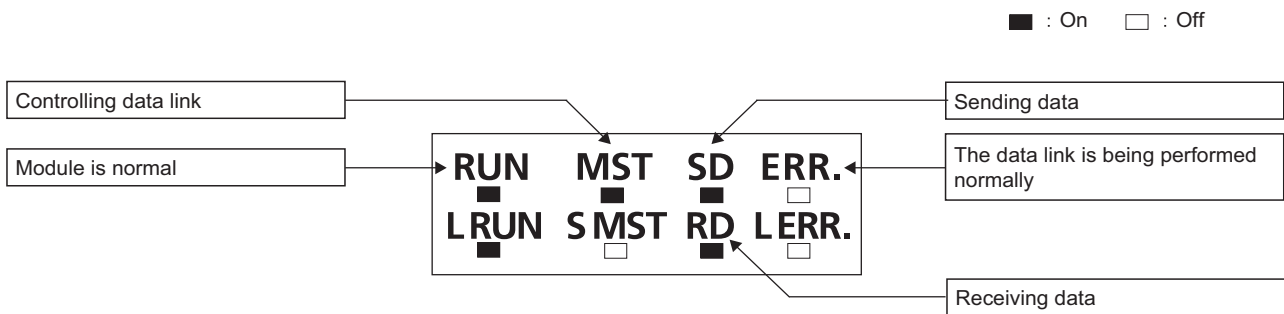

### (b) LED indication of the remote device station

For both the AJ65VBTCU-68ADV and AJ65VBTCU-68DAV, confirm that the LEDs are as follows:

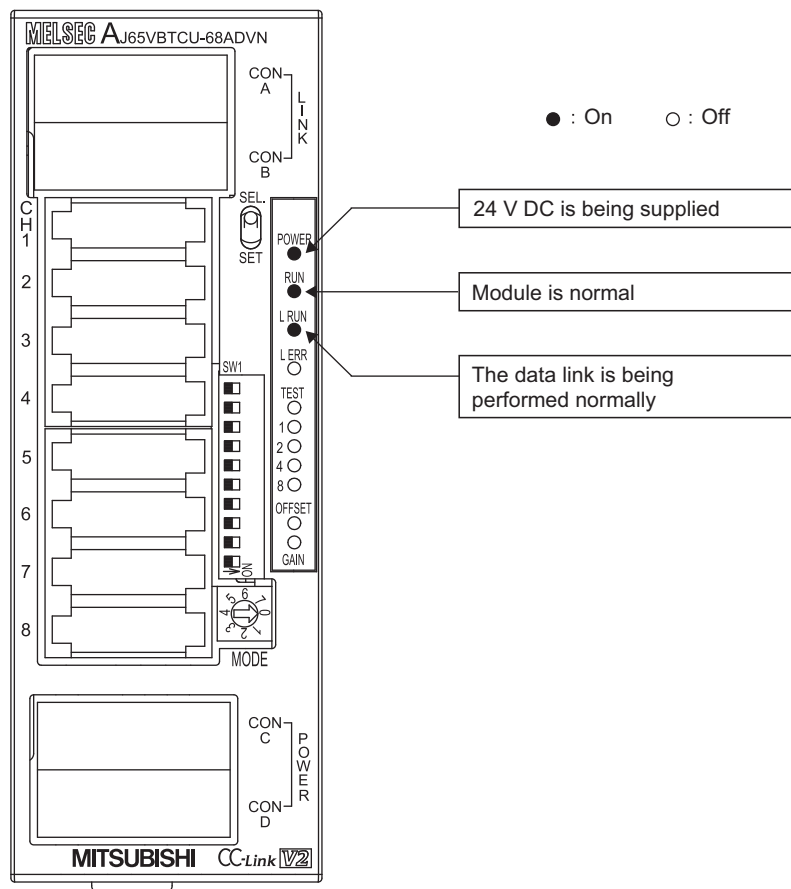

## (2) Confirming the operation with the program

Using the program, confirm that the data link is being performed normally.

Change the voltage input to the AJ65VBTCU-68ADV and confirm that the converted digital value also changes accordingly.

Set digital values to the AJ65VBTCU-68DAVN, and confirm that the voltages converted from digital to analog are output.

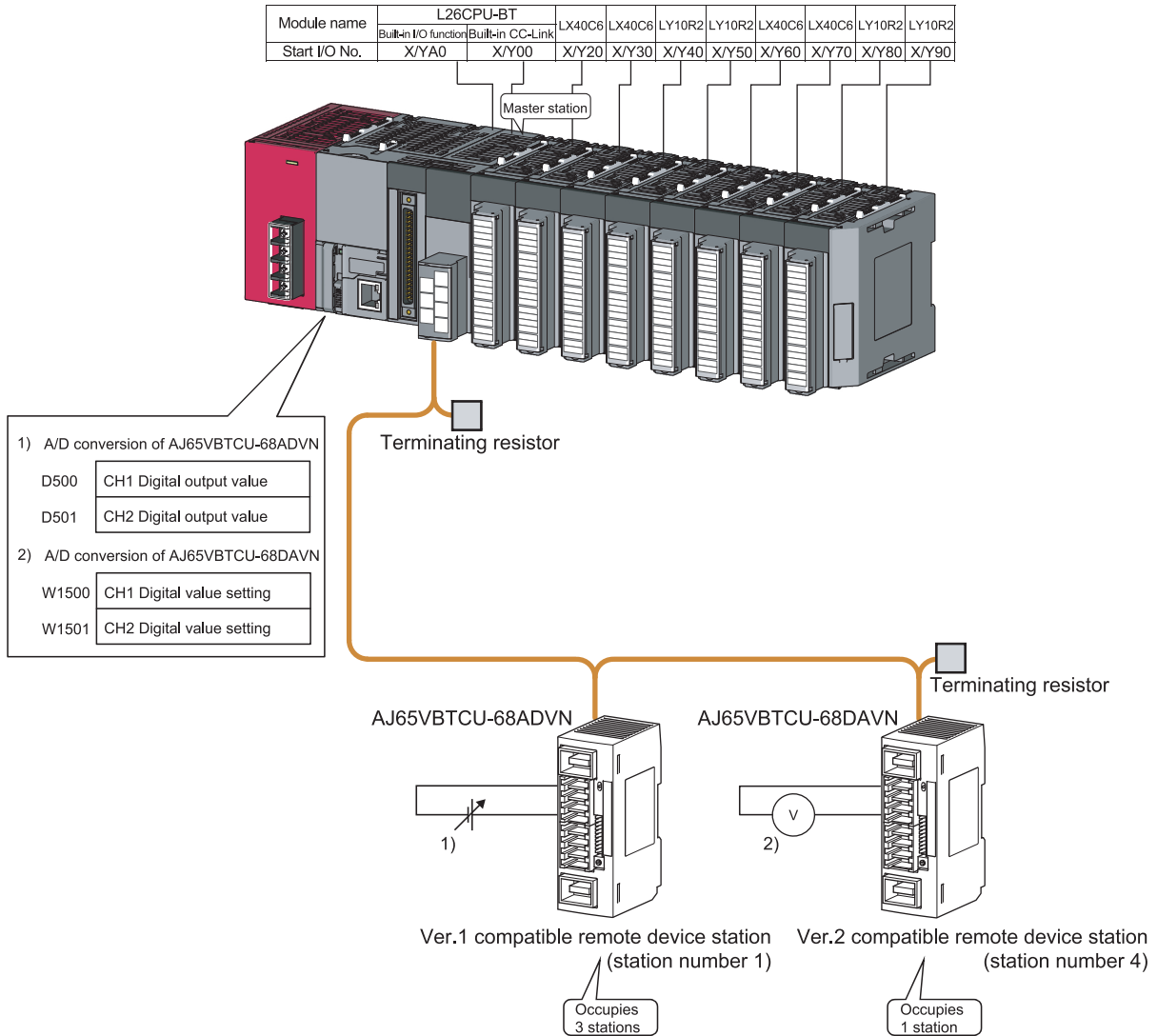

# CHAPTER 12 EXAMPLE OF COMMUNICATION BETWEEN THE MASTER STATION AND LOCAL STATIONS

This chapter explains the procedures from module settings to parameter settings, programming, and finally operation check using a system configuration example.

## 12.1 When Remote Net Ver.1 Mode is Used

### 12.1.1 Configuring a system

As shown below, a system with one local station is used as an example.

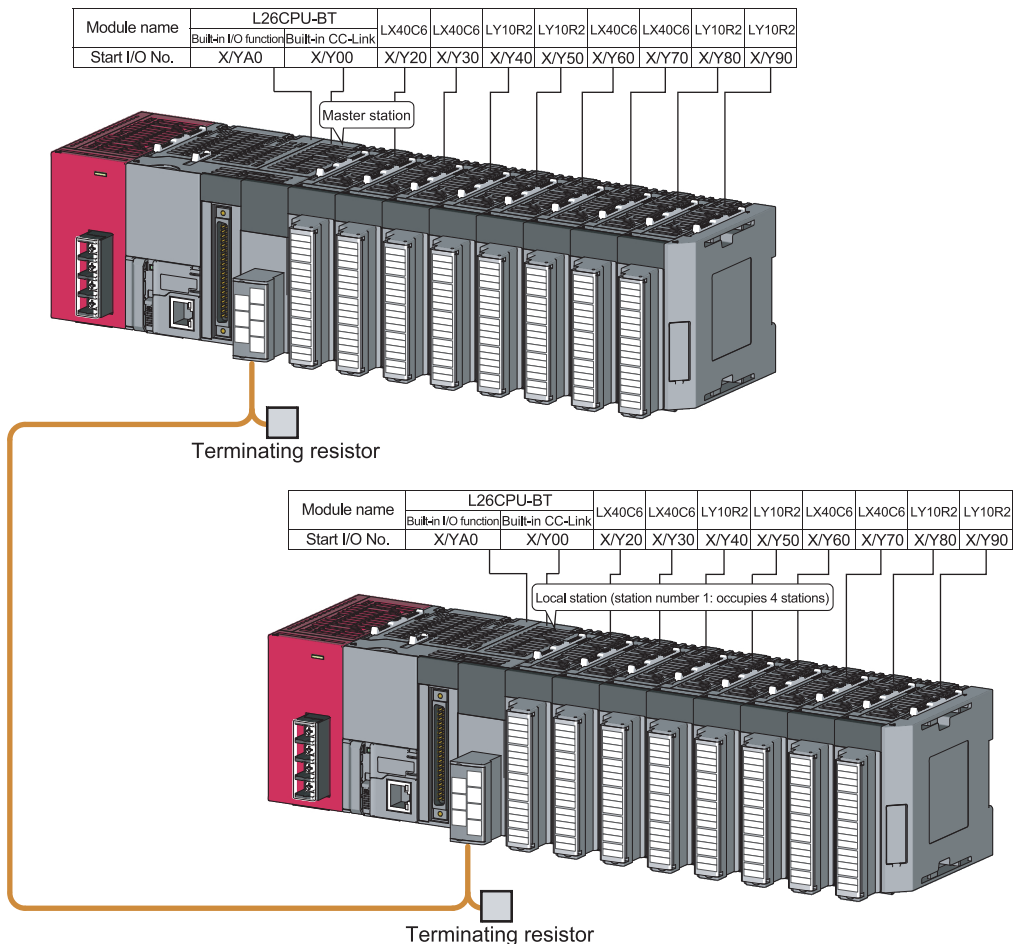

## 12.1.2 Setting the master station parameters

### (1) Setting the network parameters and automatic refresh parameters

Set the network parameters and automatic refresh parameters as follows.

Refer to Page 288, Section 12.1.2 (2) for the operation setting. Refer to Page 288, Section 12.1.2 (3) for the station information setting.

	1	
Start I/O No.	0000	
Operation Setting	Operation Setting	← Refer to Section 12.1.2 (2).
Type	Master Station	
Station No.	0	
Master Station Data Link Type	PLC Parameter Auto Start	
Mode	Remote Net(Ver.1 Mode)	
Transmission Speed	156kbps	
Total Module Connected	1	
Remote Input(RX)	X1000	
Remote Output(RY)	Y1000	
Remote Register(RWr)	W0	
Remote Register(RWw)	W100	
Ver.2 Remote Input(RX)		
Ver.2 Remote Output(RY)		
Ver.2 Remote Register(RWr)		
Ver.2 Remote Register(RWw)		
Special Relay(SB)	S0	
Special Register(SW)	SW0	
Retry Count	3	
Automatic Reconnection Station Count	1	
Standby Master Station No.		
PLC Down Select	Stop	
Scan Mode Setting	Asynchronous	
Delay Time Setting	0	
Station Information Setting	Station Information	← Refer to Section 12.1.2 (3).
Remote Device Station Initial Setting	Initial Setting	
Interrupt Setting	Interrupt Setting	

#### Point

- Do not set the same refresh devices as the following.
  - Refresh parameters of modules on the network
  - I/O numbers used for I/O modules and an intelligent function module
  - Auto refresh settings of an intelligent function module
- To set X or Y as a refresh device, set a number later than the I/O numbers used for I/O modules and an intelligent function module.

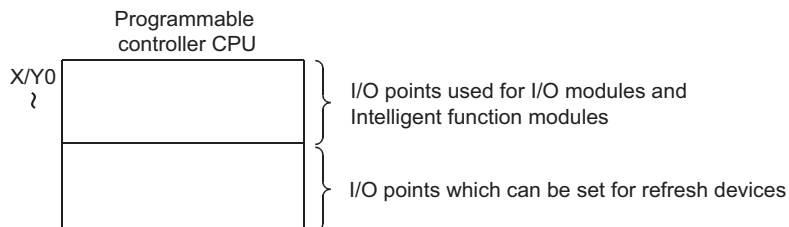

## (2) Operation setting

Set the operation setting as follows.

## (3) Station information setting

Set parameters as follows.

Station No.	Station Type	Expanded Cyclic Setting	Exclusive Count	Remote Station Points	Reserve/Invalid Station Select	Intelligent Buffer Select(Word)		
						Send	Receive	Automatic
1/1	Intelligent Device Station	Single	Exclusive Station 4	128 Points	No Setting	64	64	128

"Intelligent Device Station" of "Station Type" includes local station and standby master station.

## 12.1.3 Setting the local station parameters

### (1) Setting the network parameters and automatic refresh parameters

Set the network parameters and automatic refresh parameters as follows.

For the operation setting, refer to Section  Page 290, Section 12.1.3 (2).

	1
Start I/O No.	0000
Operation Setting	Operation Setting
Type	Local Station
Station No.	1
Master Station Data Link Type	
Mode	Remote Net(Ver.1 Mode)
Transmission Speed	Auto Following
Total Module Connected	
Remote Input(RX)	X1000
Remote Output(RY)	Y1000
Remote Register(RWr)	W0
Remote Register(RWw)	W100
Ver.2 Remote Input(RX)	
Ver.2 Remote Output(RY)	
Ver.2 Remote Register(RWr)	
Ver.2 Remote Register(RWw)	
Special Relay(SB)	SB0
Special Register(SW)	SW0
Retry Count	
Automatic Reconnection Station Count	
Standby Master Station No.	
PLC Down Select	
Scan Mode Setting	
Delay Time Setting	
Station Information Setting	
Remote Device Station Initial Setting	
Interrupt Setting	Interrupt Setting

Refer to Section 12.1.3 (2).

12

### Point

- Do not set the same refresh devices as the following.
  - Refresh parameters of modules on the network
  - I/O numbers used for I/O modules and an intelligent function module
  - Auto refresh settings of an intelligent function module
- To set X or Y as a refresh device, set a number later than the I/O numbers used for I/O modules and an intelligent function module.

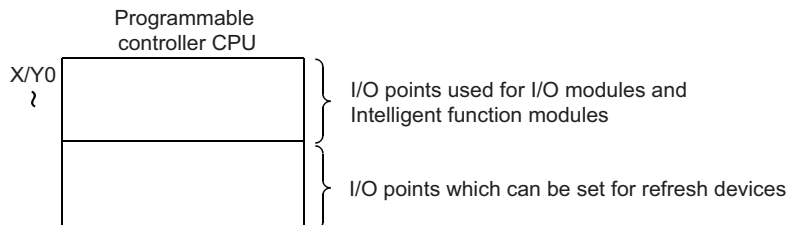

12.1 When Remote Net Ver. 1 Mode is Used  
12.1.3 Setting the local station parameters

## (2) Operation setting

Set the operation setting as follows.

Operation Setting Module 1

Parameter Name

Number of Occupied Stations

Occupied Stations 4

Data Link Faulty Station Setting

Hold Input Data

Expanded Cyclic Setting

Single

Case of CPU STOP Setting

Clears Compulsorily

Block Data Assurance per Station

Enable Setting

Auto Detect: Setting of the Connected Device  
Please select: Read Model Name of Slave Station in Auto Detection of the connected device.  
The start of data link may be slow after selecting the item.

Read Model Name of Slave Station

OK Cancel



## 12.1.4 Creating a program

This section shows the program to be used for communication between the master and local stations.

The following diagram shows the relationship between the devices of the master station programmable controller CPU and the devices of the local station programmable controller CPU.

The shaded areas indicate the devices that are actually used.

[Remote input (RX) and remote output (RY)]

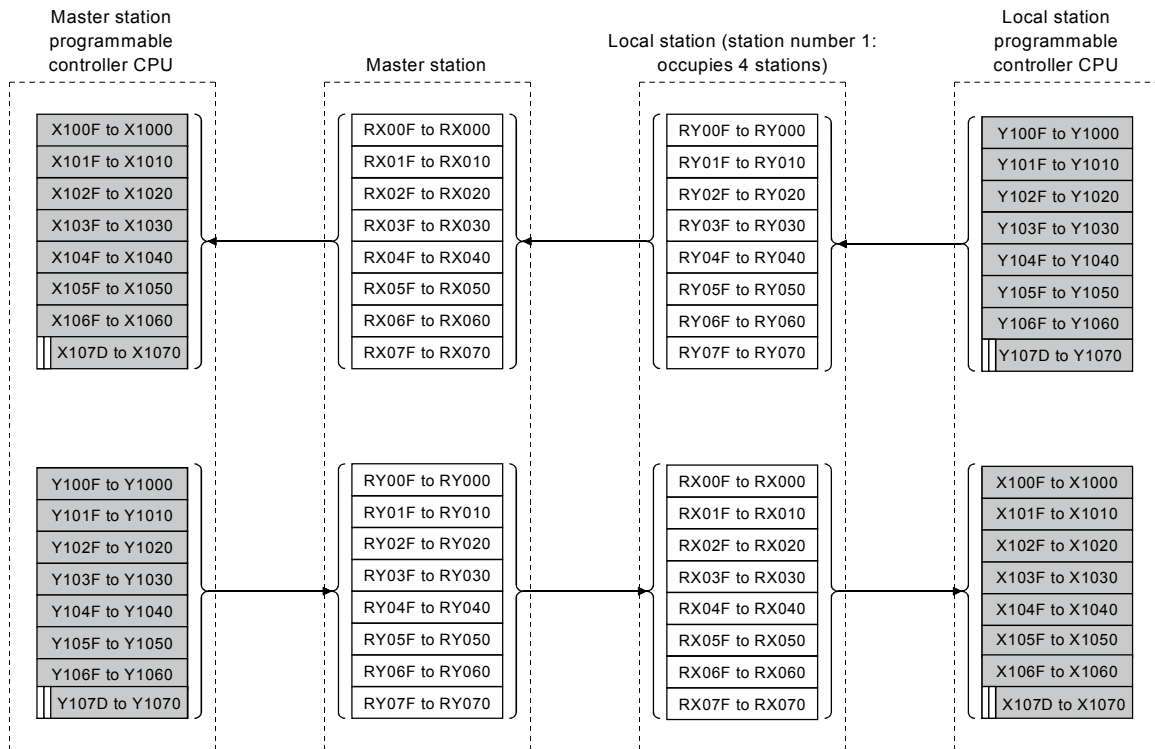

□ □ ..... The last two bits cannot be used for communication between the master and local stations.

[Remote registers (RWw and RWr)]

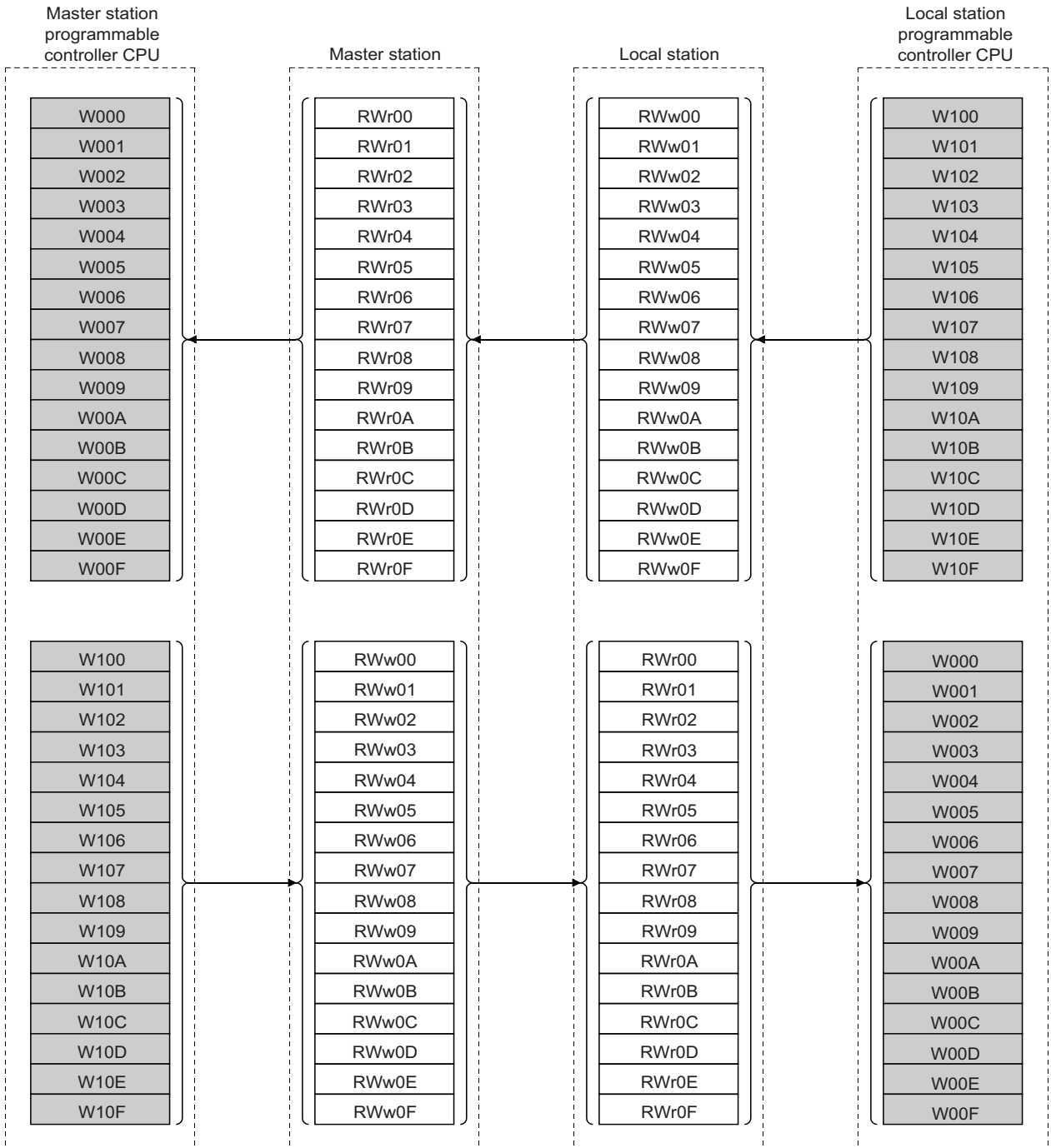

### (1) Master station program

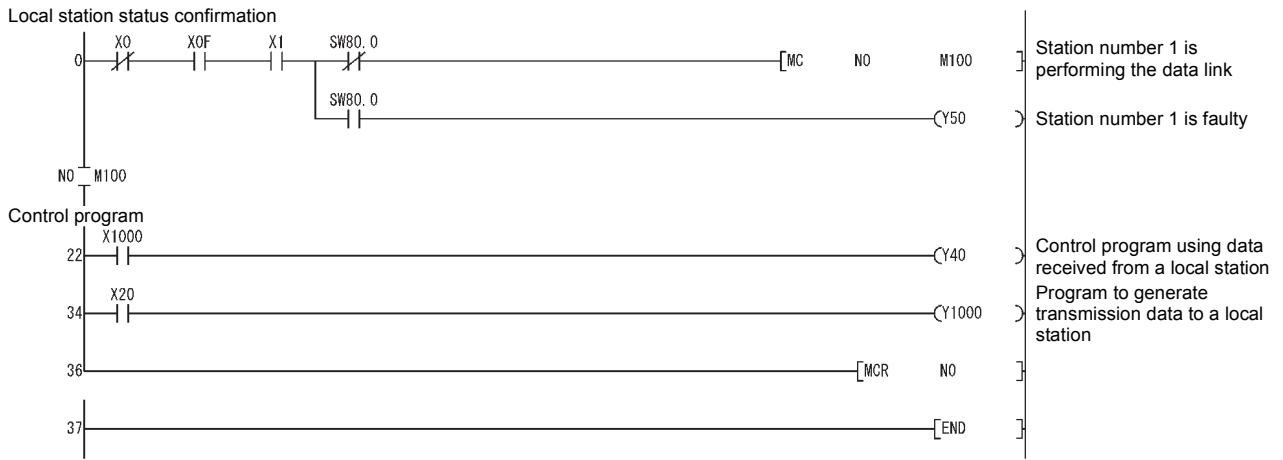

### (2) Local station program

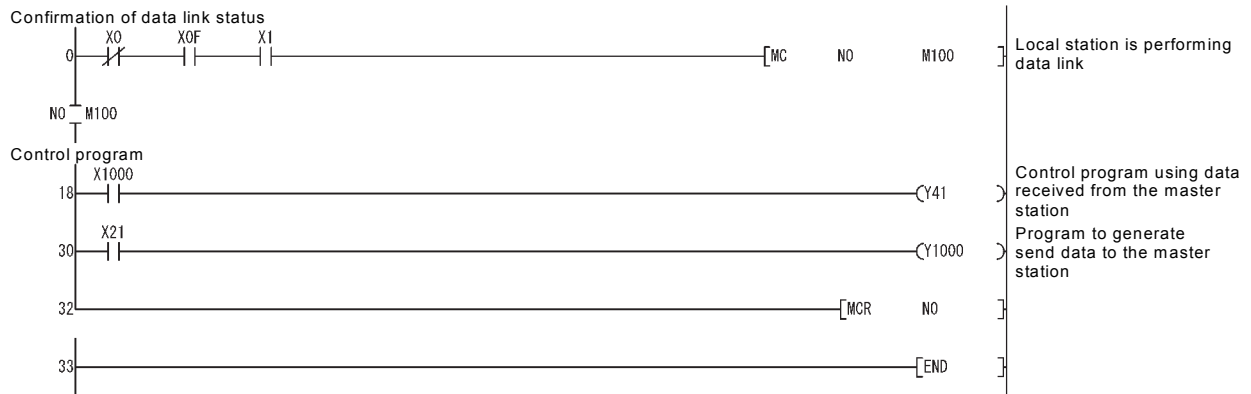

**Remark**

By enabling "Block Data Assurance per Station", the consistency of the cyclic data for each slave station can be guaranteed.

(Page 159, Section 8.2.9) \*1

\*1 Data of more than one station are not guaranteed.

Also, to configure an interlock in the program, do so by using remote I/O (RX/RX) as shown below.

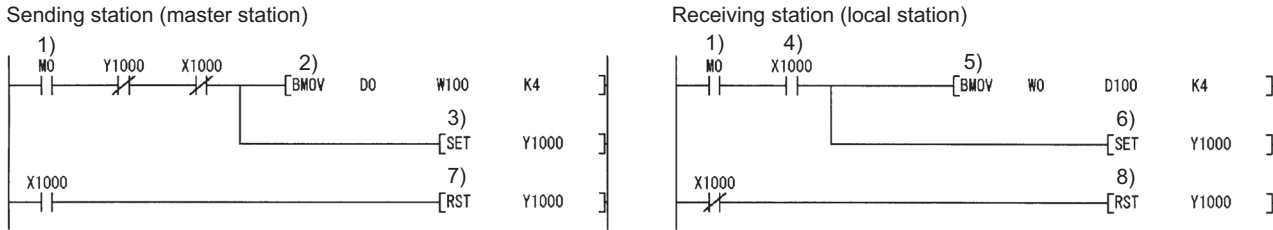

1)The send/receive command (M0) turns ON.

2)Data of D0 to D3 are stored in W100 to W103 (RWw0 to RWw3).

3)Upon completion of storage in W100 to W103, Y1000 (RY0) for handshake turns ON. \*2

4)By cyclic transmission, remote output (RY) data are sent following the remote register (RWw) data, and the receiving station's X1000 (RX0) is turned ON.

5)Data of W0 to W3 (RWr0 to RWr3) are stored in D100 to D103.

6)Upon completion of storage in D100 to D103, Y1000 (RY0) for handshake turns ON. \*2

7)When the receiving station's Y1000 turns ON, the sending station's Y1000 turns OFF.

8)When the sending station's Y1000 turns OFF, the receiving station's Y1000 turns OFF.

\*2 Even if the number of occupied stations is two or more, the consistency of the cyclic data for each slave station can be guaranteed by performing handshaking with one bit of remote I/O (RX/RX). The interlocks for all occupied stations (in units of 4 words) are not necessary.

## 12.1.5 Performing the data link

Turn on the local station first, and then the master station to start the data link.

### (1) Confirming the operation with the LED indicators

The following diagram shows the LED status of the master station and the local station when the data link is being performed normally.

#### (a) LED indication of the master station

Make sure that the LEDs are as follows:

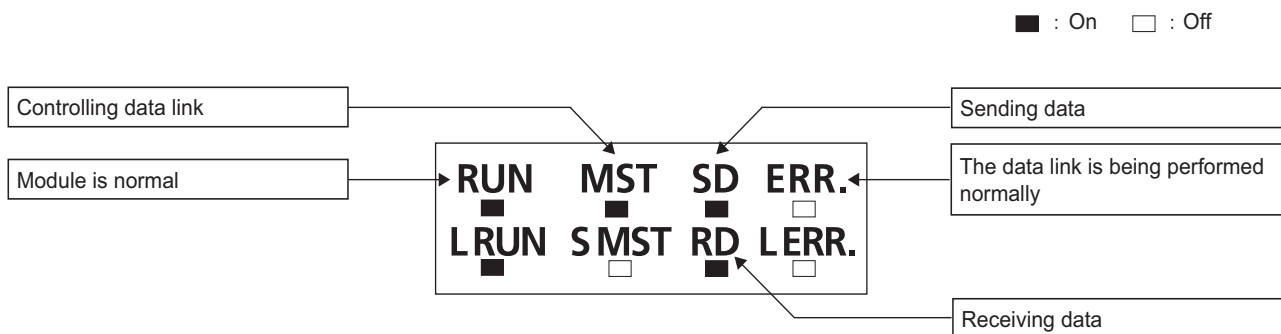

#### (b) LED indication of the local station

Make sure that the LEDs are as follows:

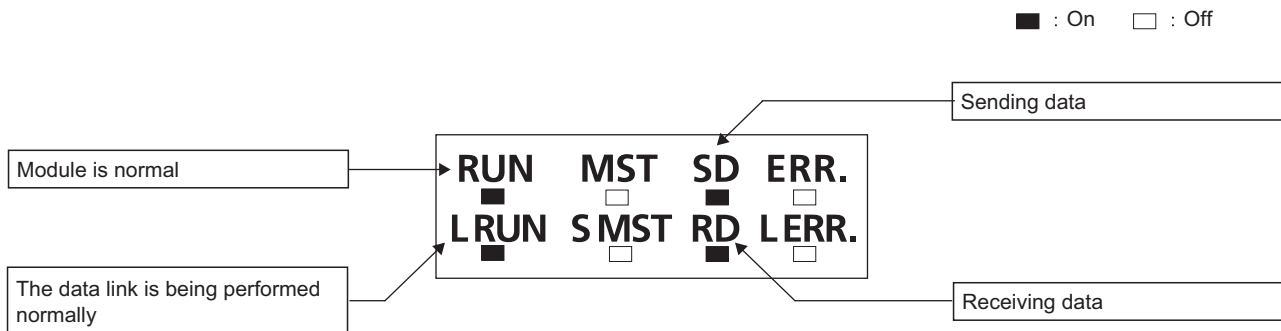

## (2) Confirming the operation with the program

Using the program, confirm that the data link is being performed normally.

- 1) When X20 of the master station is turned on, Y41 of the local station turns on.
- 2) When X21 of the local station is turned on, Y40 of the master station turns on.

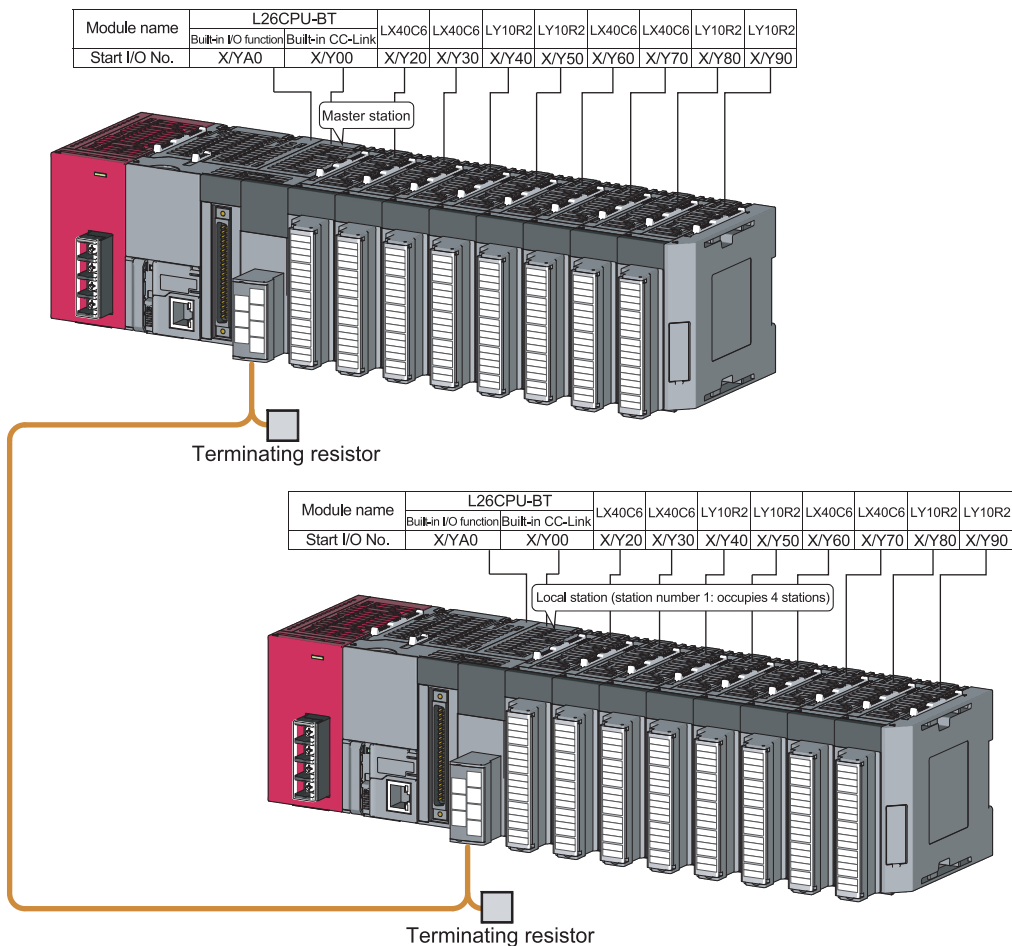

# 12.2 When Remote Net Ver.2 Mode is Used

## 12.2.1 Configuring a system

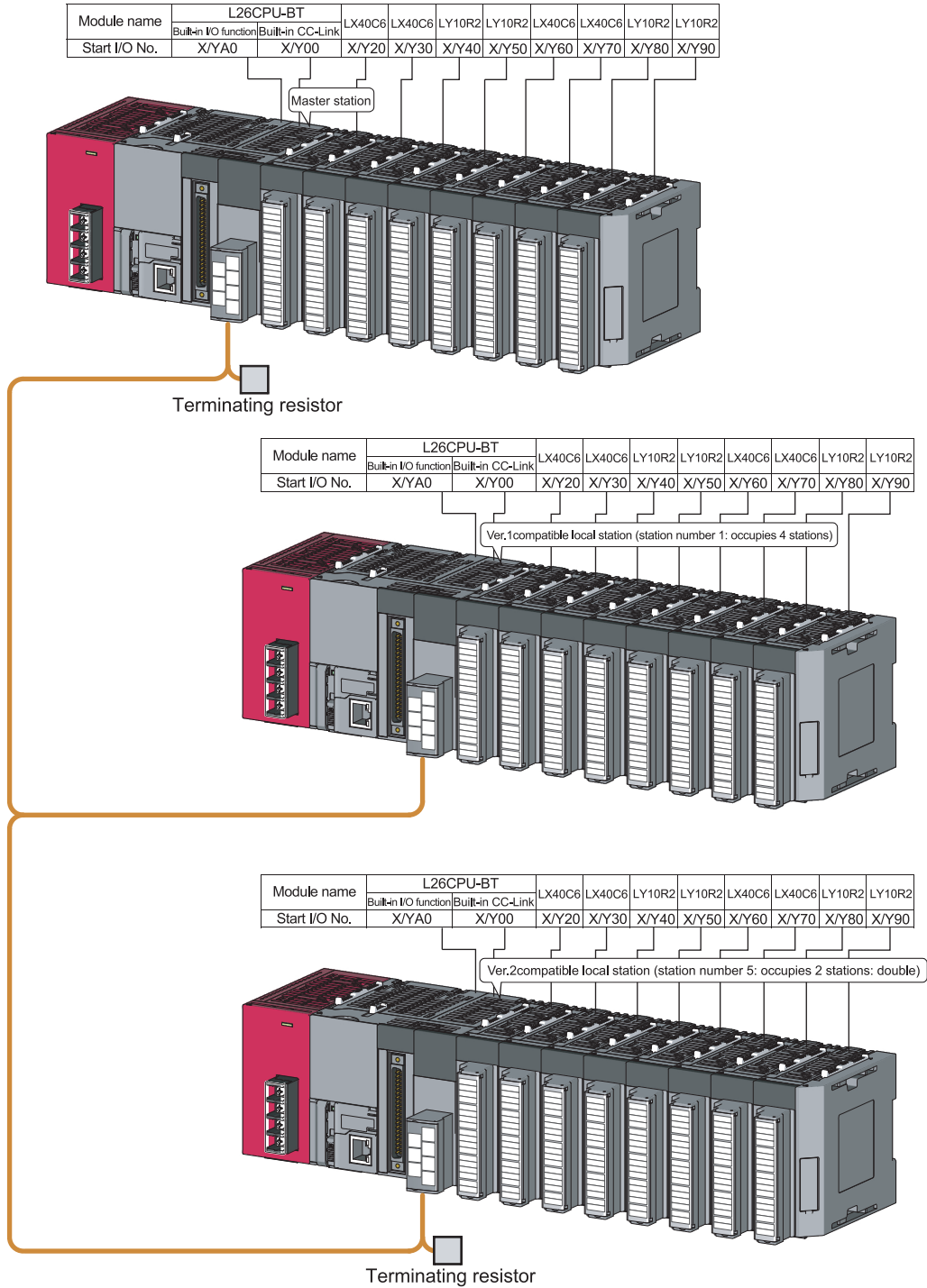

As shown below, a system with two local stations is used as an example.



## 12.2.2 Setting the master station parameters

### (1) Setting the network parameters and automatic refresh parameters

Set the network parameters and automatic refresh parameters as follows.

Refer to  Page 299, Section 12.2.2 (2) for the operation setting. Refer to  Page 299, Section 12.2.2 (3) for the station information setting.

	1	
Start I/O No.	0000	
Operation Setting	Operation Setting	← Refer to Section 12.2.2 (2).
Type	Master Station	
Station No.	0	
Master Station Data Link Type	PLC Parameter Auto Start	
Mode	Remote Net(Ver.2 Mode)	
Transmission Speed	156kbps	
Total Module Connected	2	
Remote Input(RX)	X1000	
Remote Output(RY)	Y1000	
Remote Register(RWr)	W0	
Remote Register(RWw)	W1000	
Ver.2 Remote Input(RX)		
Ver.2 Remote Output(RY)		
Ver.2 Remote Register(RWr)		
Ver.2 Remote Register(RWw)		
Special Relay(SB)	S0	
Special Register(SW)	SW0	
Retry Count	3	
Automatic Reconnection Station Count	1	
Standby Master Station No.		
PLC Down Select	Stop	
Scan Mode Setting	Asynchronous	
Delay Time Setting	0	
Station Information Setting	Station Information	← Refer to Section 12.2.2 (3).
Remote Device Station Initial Setting	Initial Setting	
Interrupt Setting	Interrupt Setting	

### Point

- Do not set the same refresh devices as the following.
  - Refresh parameters of modules on the network
  - I/O numbers used for I/O modules and an intelligent function module
  - Auto refresh settings of an intelligent function module
- To set X or Y as a refresh device, set a number later than the I/O numbers used for I/O modules and an intelligent function module.

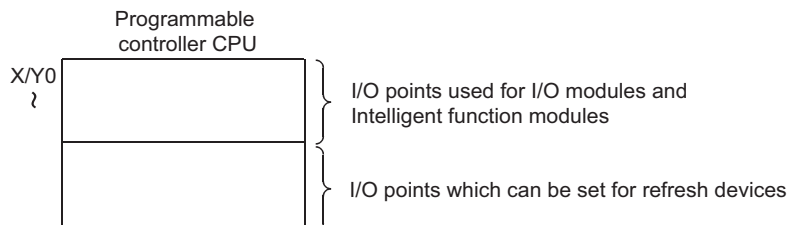



**(2) Operation setting**

Set the operation setting as follows.

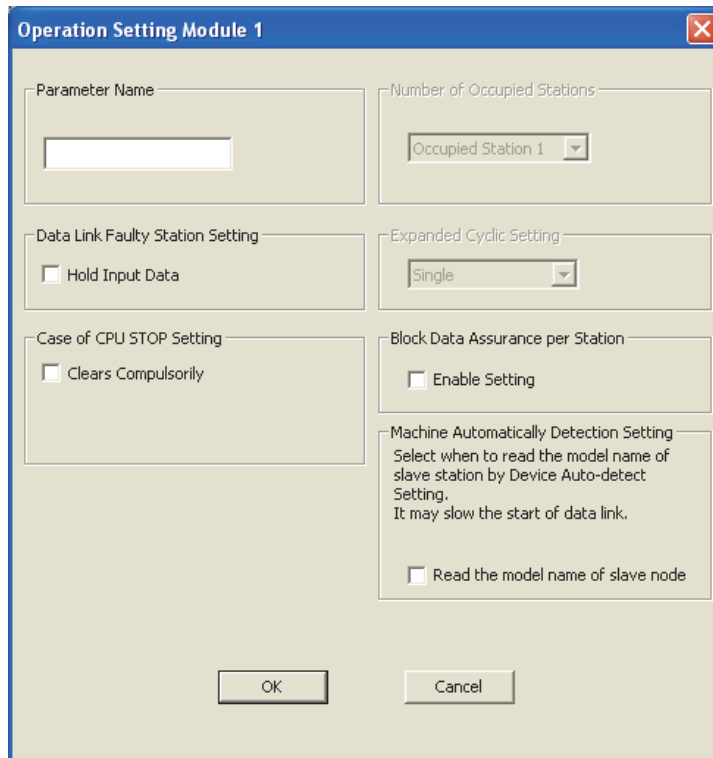

**(3) Station information setting**

Set parameters as follows.

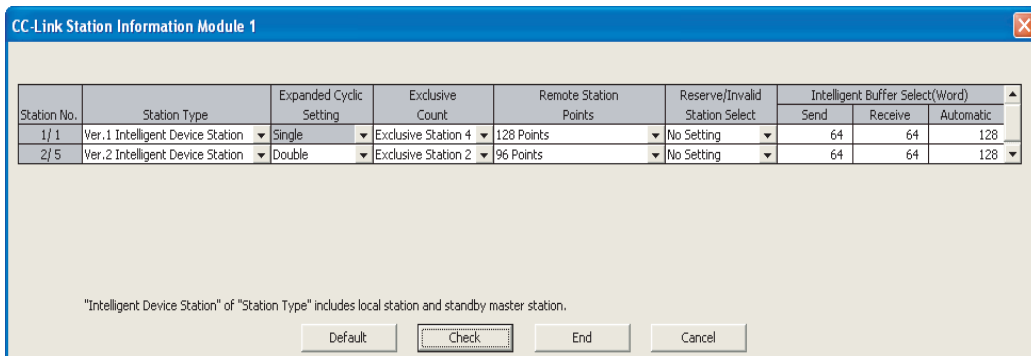

## 12.2.3 Setting the local station parameters

### (1) Setting the parameters of the Ver.1 compatible local station (station number 1)

#### (a) Setting the network parameters and automatic refresh parameters

Set the network parameters and automatic refresh parameters as follows.

For the operation setting, refer to  Page 301, Section 12.2.3 (1) (b).

Start I/O No.	1	0000	
Operation Setting	Operation Setting		← Refer to Section 12.2.3 (1) (b).
Type	Local Station		
Station No.	1		
Master Station Data Link Type			
Mode	Remote Net(Ver.1 Mode)		
Transmission Speed	Auto Following		
Total Module Connected			
Remote Input(RX)		X1000	
Remote Output(RY)		Y1000	
Remote Register(RWr)		W0	
Remote Register(RWw)		W1000	
Ver.2 Remote Input(RX)			
Ver.2 Remote Output(RY)			
Ver.2 Remote Register(RWr)			
Ver.2 Remote Register(RWw)			
Special Relay(SB)		S0	
Special Register(SW)		SW0	
Retry Count			
Automatic Reconnection Station Count			
Standby Master Station No.			
PLC Down Select			
Scan Mode Setting			
Delay Time Setting			
Station Information Setting			
Remote Device Station Initial Setting			
Interrupt Setting	Interrupt Setting		

#### Point

- Do not set the same refresh devices as the following.
  - Refresh parameters of modules on the network
  - I/O numbers used for I/O modules and an intelligent function module
  - Auto refresh settings of an intelligent function module
- To set X or Y as a refresh device, set a number later than the I/O numbers used for I/O modules and an intelligent function module.

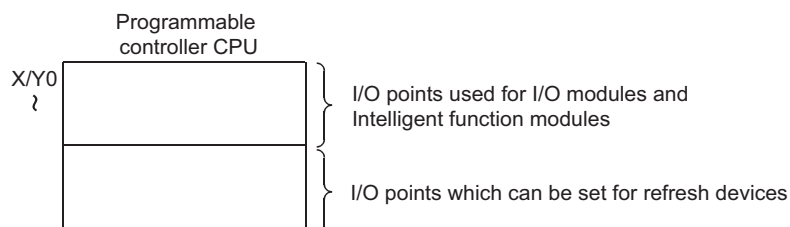

**(b) Operation setting**

Set the operation setting as follows.

The screenshot shows a dialog box titled "Operation Setting Module 1". It contains the following settings:

- Parameter Name:** An empty text input field.
- Number of Occupied Stations:** A dropdown menu currently showing "Occupied Stations 4".
- Data Link Faulty Station Setting:** A checkbox labeled "Hold Input Data" which is unchecked.
- Expanded Cyclic Setting:** A dropdown menu currently showing "Single".
- Case of CPU STOP Setting:** A checkbox labeled "Clears Compulsorily" which is unchecked.
- Block Data Assurance per Station:** A checkbox labeled "Enable Setting" which is unchecked.
- Auto Detect Setting of the Connected Device:** A section with explanatory text: "Please select Read Model Name of Slave Station in Auto Detection of the connected device. The start of data link may be slow after selecting the item." Below this text is a checkbox labeled "Read Model Name of Slave Station" which is unchecked.

At the bottom of the dialog are "OK" and "Cancel" buttons.

## (2) Setting the parameters of the Ver.2 compatible local station (station number 5)

### (a) Setting the network parameters and automatic refresh parameters

Set the network parameters and automatic refresh parameters as follows.

For the operation setting, refer to  Page 303, Section 12.2.3 (2) (b).

	1
Start I/O No.	0000
Operation Setting	Operation Setting
Type	Local Station
Station No.	5
Master Station Data Link Type	
Mode	Remote Net(Ver.2 Mode)
Transmission Speed	Auto Following
Total Module Connected	
Remote Input(RX)	X1000
Remote Output(RY)	Y1000
Remote Register(RWr)	W0
Remote Register(RWw)	W1000
Ver.2 Remote Input(RX)	
Ver.2 Remote Output(RY)	
Ver.2 Remote Register(RWr)	
Ver.2 Remote Register(RWw)	
Special Relay(SB)	SB0
Special Register(SW)	SW0
Retry Count	
Automatic Reconnection Station Count	
Standby Master Station No.	
PLC Down Select	
Scan Mode Setting	
Delay Time Setting	
Station Information Setting	
Remote Device Station Initial Setting	
Interrupt Setting	Interrupt Setting

← Refer to Section 12.2.3 (2) (b).

### Point

- Do not set the same refresh devices as the following.
  - Refresh parameters of modules on the network
  - I/O numbers used for I/O modules and an intelligent function module
  - Auto refresh settings of an intelligent function module
- To set X or Y as a refresh device, set a number later than the I/O numbers used for I/O modules and an intelligent function module.

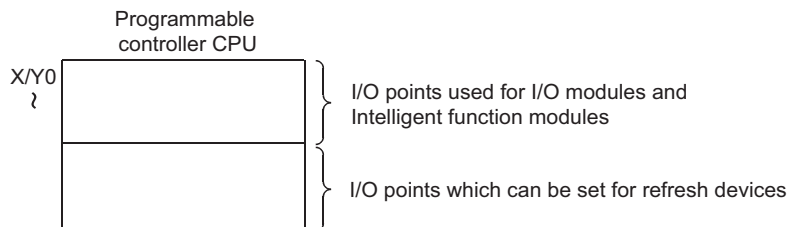

**(b) Operation setting**

Set the operation setting as follows.

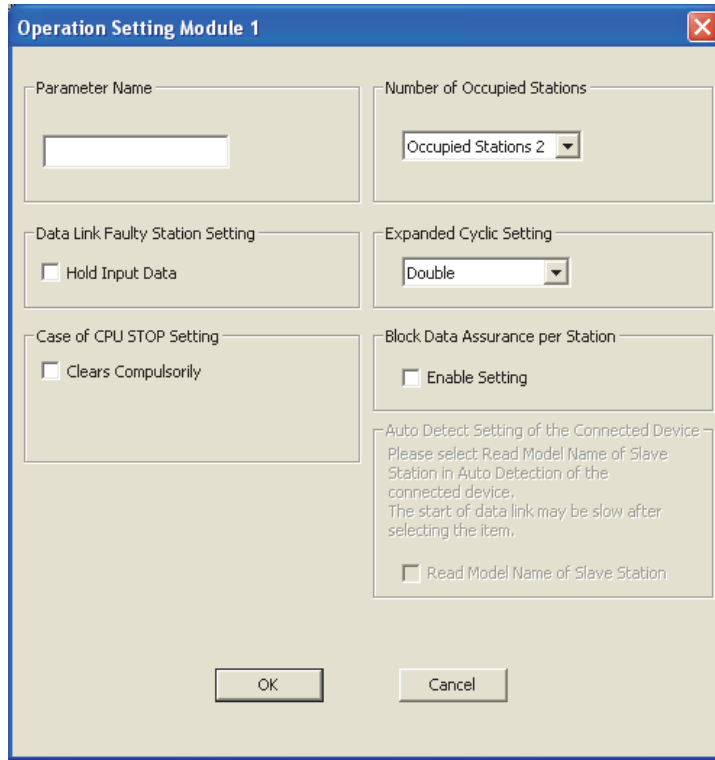

## 12.2.4 Creating a program

This section shows the program to be used for communication between the master and local stations.

The following diagram shows the relationship between the devices of the master station programmable controller CPU and the devices of the local station programmable controller CPU.

The shaded areas indicate the devices that are actually used.

[Remote input (RX) and remote output (RY)]

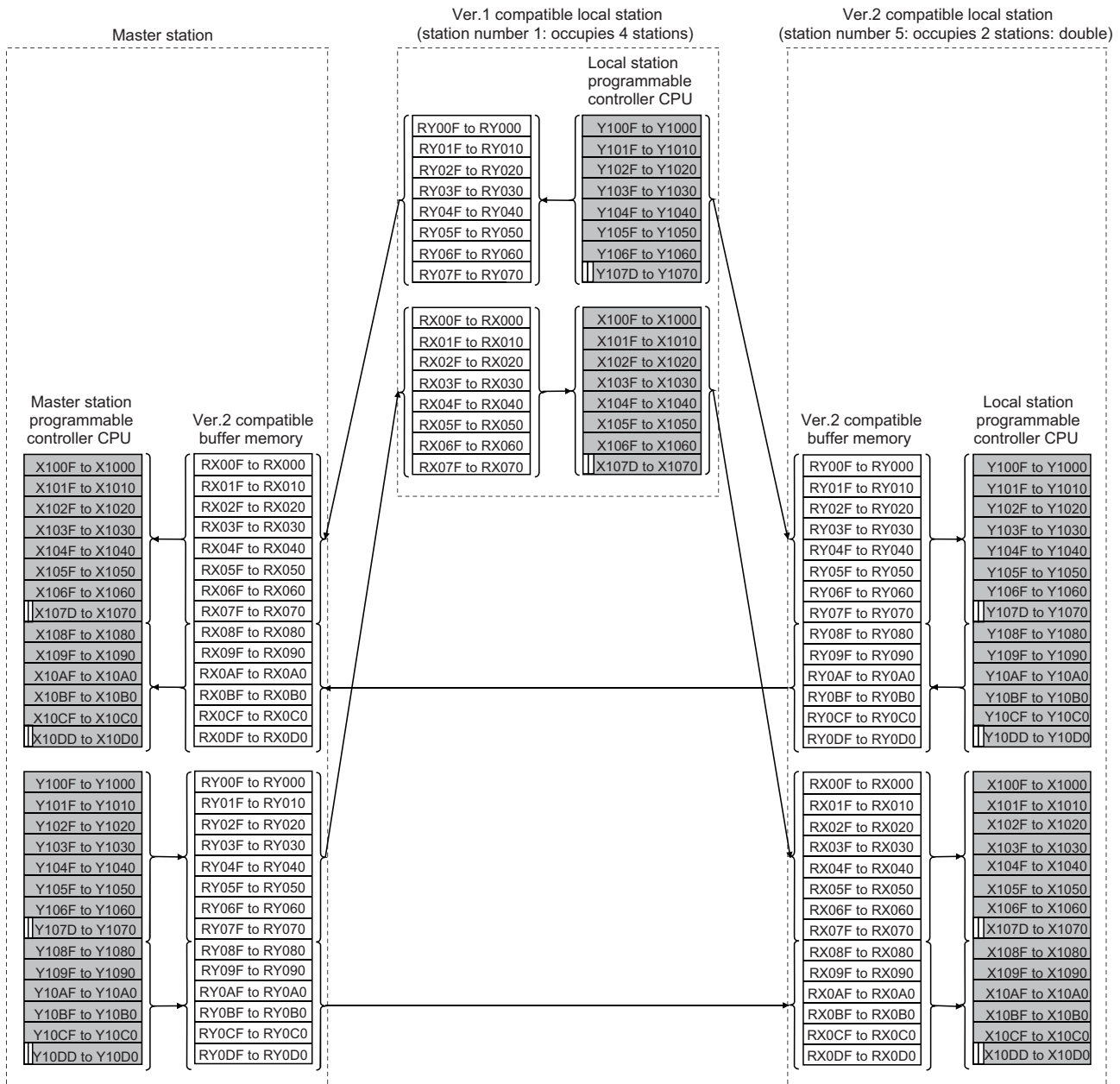

[Remote registers (RWw and RWr)]

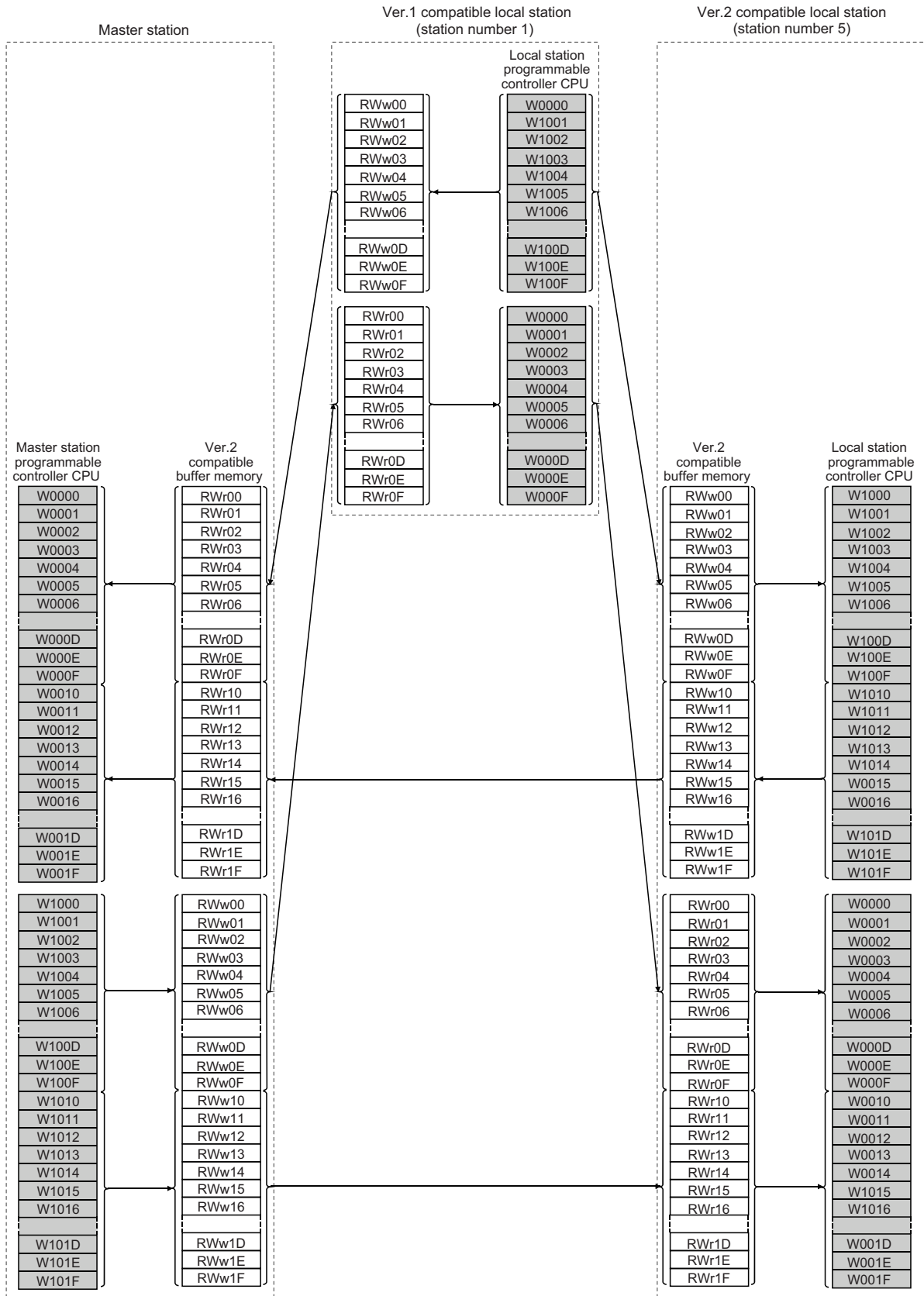

12.2 When Remote Net Ver.2 Mode is Used  
12.2.4 Creating a program





**(b) Ver.2 compatible local station (station number 5) program**

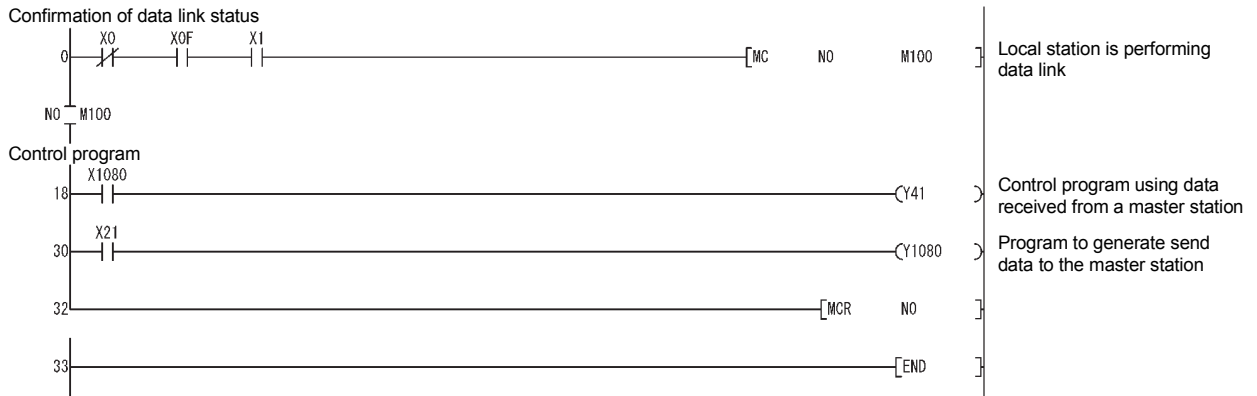

**Remark**

By enabling "Block Data Assurance per Station", the consistency of the cyclic data for each slave station can be guaranteed. (Refer to Page 159, Section 8.2.9)

Also, to configure an interlock in the program, refer to REMARK in Page 291, Section 12.1.4.

## 12.2.5 Performing the data link

Turn on the local stations first, and then the master station to start the data link.

### (1) Confirming the operation with the LED indicators

The following diagram shows the LED status of the master station and the local station when the data link is being performed normally.

#### (a) LED indication of the master station

Make sure that the LEDs are as follows:

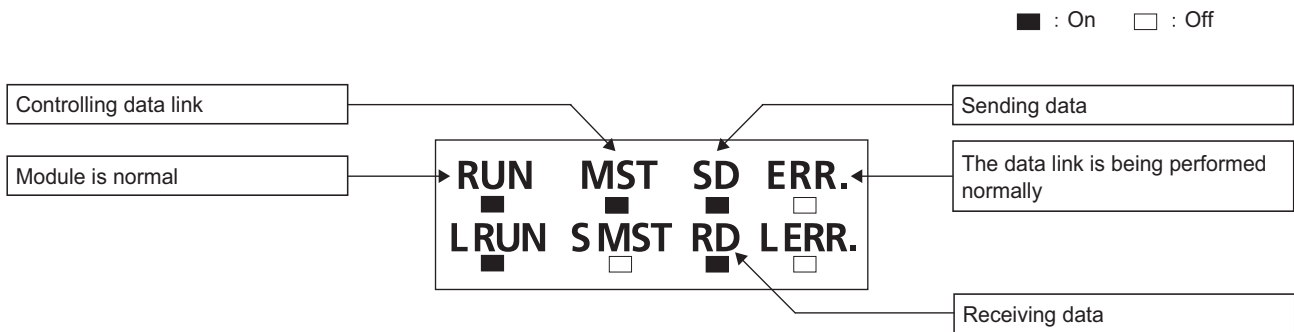

#### (b) LED indication of the local station

Make sure that the LEDs are as follows:

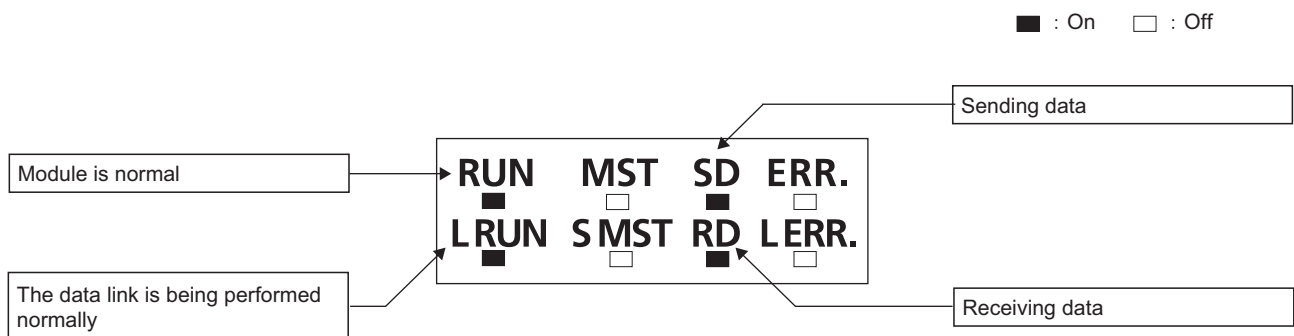

## (2) Confirming the operation with the program

Using the program, confirm that the data link is being performed normally.

- When X20 of the master station is turned on, Y41 of local station No. 1 turns on.
- When X21 of local station No. 1 is turned on, Y40 of the master station turns on.
- When X21 of the master station is turned on, Y41 of local station No. 5 turns on.
- When X21 of local station No. 5 is turned on, Y41 of the master station turns on.

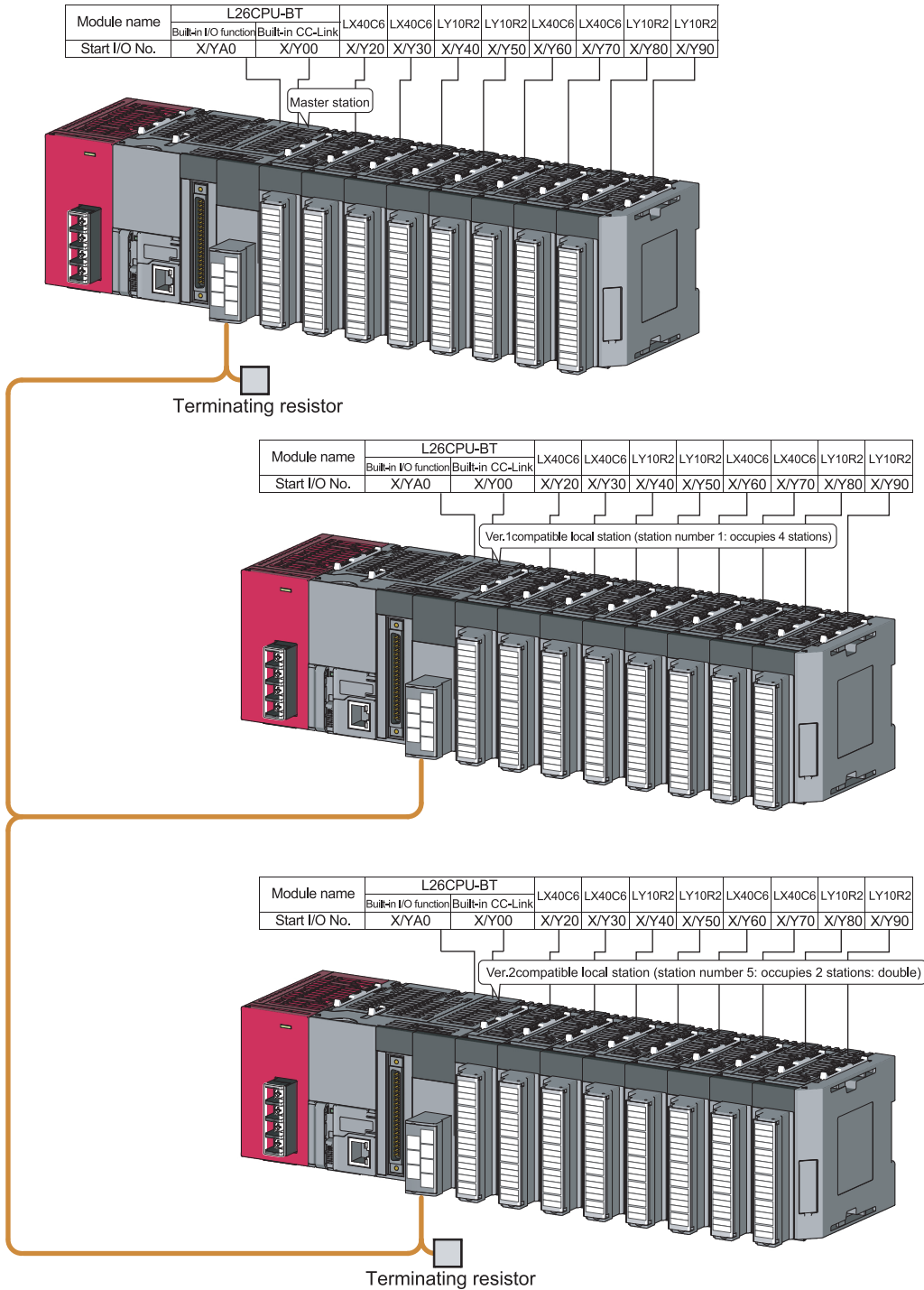

# 12.3 When Remote Net Additional Mode is Used

## 12.3.1 Configuring a system

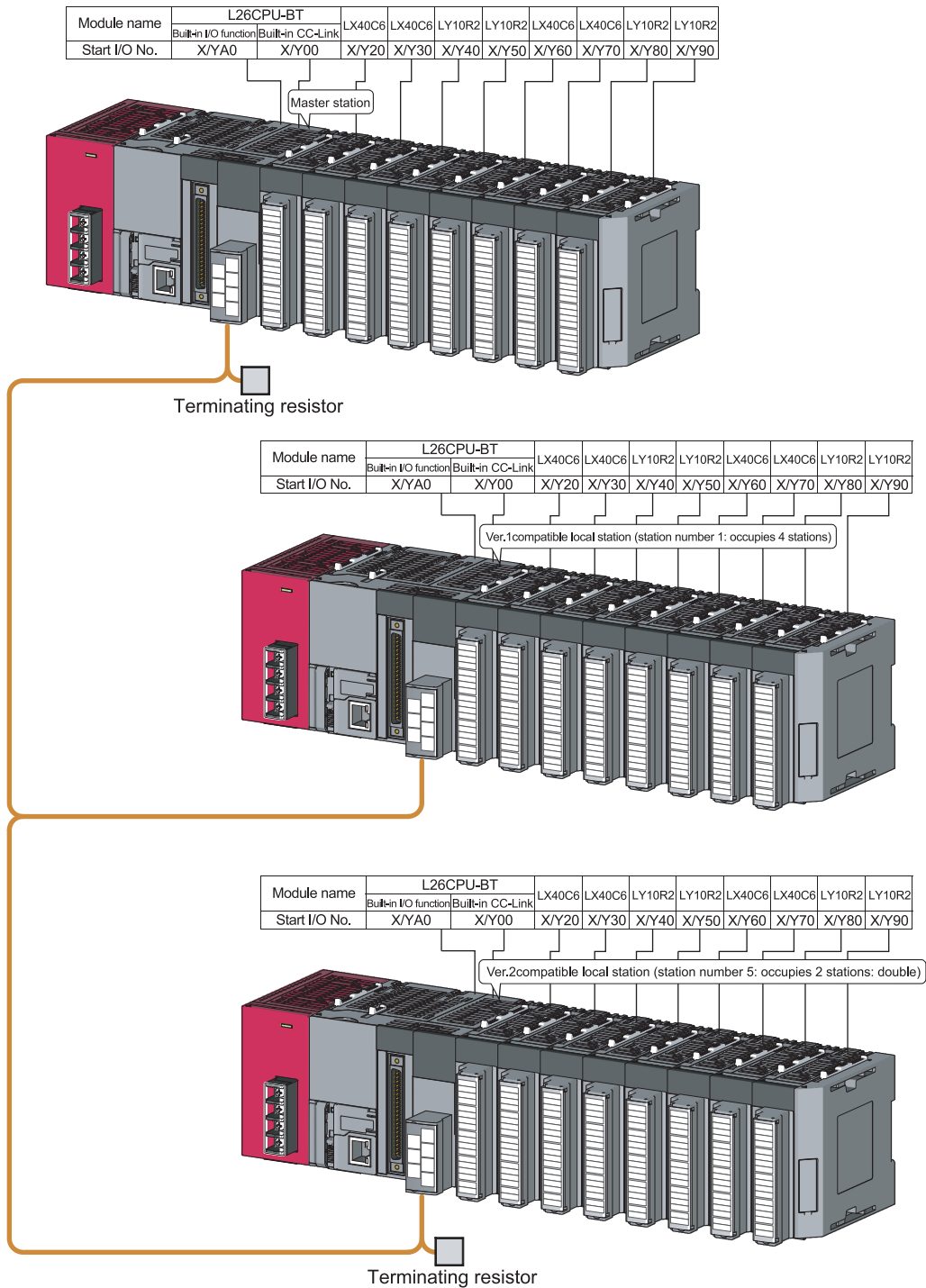

As shown below, a system with two local stations is used as an example.



## 12.3.2 Setting the master station parameters

### (1) Setting the network parameters and automatic refresh parameters

Set the network parameters and automatic refresh parameters as follows.

Refer to  Page 312, Section 12.3.2 (2) for the operation setting. Refer to  Page 312, Section 12.3.2 (3) for the station information setting.

Start I/O No.	1	0000	
Operation Setting	Operation Setting		← Refer to Section 12.3.2 (2).
Type	Master Station	▼	
Station No.	0		
Master Station Data Link Type	PLC Parameter Auto Start	▼	
Mode	Remote Net(Additional Mode)	▼	
Transmission Speed	156kbps	▼	
Total Module Connected	2		
Remote Input(RX)	X1000		
Remote Output(RY)	Y1000		
Remote Register(RWr)	W0		
Remote Register(RWw)	W100		
Ver.2 Remote Input(RX)	X1500		
Ver.2 Remote Output(RY)	Y1500		
Ver.2 Remote Register(RWr)	W1000		
Ver.2 Remote Register(RWw)	W1500		
Special Relay(SB)	SB0		
Special Register(SW)	SW0		
Retry Count	3		
Automatic Reconnection Station Count	1		
Standby Master Station No.			
PLC Down Select	Stop	▼	
Scan Mode Setting	Asynchronous	▼	
Delay Time Setting	0		
Station Information Setting	Station Information		← Refer to Section 12.3.2 (3).
Remote Device Station Initial Setting	Initial Setting		
Interrupt Setting	Interrupt Setting		

### Point

- Do not set the same refresh devices as the following.
  - Refresh parameters of modules on the network
  - I/O numbers used for I/O modules and an intelligent function module
  - Auto refresh settings of an intelligent function module
- To set X or Y as a refresh device, set a number later than the I/O numbers used for I/O modules and an intelligent function module.

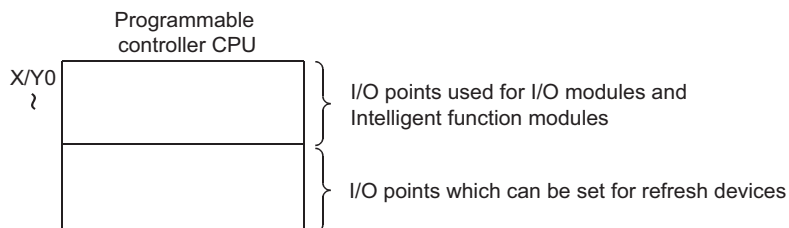

## (2) Operation setting

Set the operation setting as follows.

## (3) Station information setting

Set parameters as follows.

Station No.	Station Type	Expanded Cyclic Setting	Exclusive Count	Remote Station Points	Reserve/Invalid Station Select	Intelligent Buffer Select(Word)		
						Send	Receive	Automatic
1/ 1	Ver.1 Intelligent Device Station	Single	Exclusive Station 4	128 Points	No Setting	64	64	128
2/ 5	Ver.2 Intelligent Device Station	Double	Exclusive Station 2	96 Points	No Setting	64	64	128

"Intelligent Device Station" of "Station Type" includes local station and standby master station.

## 12.3.3 Setting the local station parameters

### (1) Setting the parameters of the Ver.1 compatible local station (station number 1)

#### (a) Setting the network parameters and automatic refresh parameters

Set the network parameters and automatic refresh parameters as follows.

For the operation setting, refer to  Page 314, Section 12.3.3 (1) (b).

	1
Start I/O No.	0000
Operation Setting	Operation Setting
Type	Local Station
Station No.	1
Master Station Data Link Type	
Mode	Remote Net(Ver.1 Mode)
Transmission Speed	Auto Following
Total Module Connected	
Remote Input(RX)	X1000
Remote Output(RY)	Y1000
Remote Register(RWr)	W0
Remote Register(RWw)	W100
Ver.2 Remote Input(RX)	
Ver.2 Remote Output(RY)	
Ver.2 Remote Register(RWr)	
Ver.2 Remote Register(RWw)	
Special Relay(SB)	SB0
Special Register(SW)	SW0
Retry Count	
Automatic Reconnection Station Count	
Standby Master Station No.	
PLC Down Select	
Scan Mode Setting	
Delay Time Setting	
Station Information Setting	
Remote Device Station Initial Setting	
Interrupt Setting	Interrupt Setting

Refer to Section 12.3.3 (1) (b).

12

#### Point

- Do not set the same refresh devices as the following.
  - Refresh parameters of modules on the network
  - I/O numbers used for I/O modules and an intelligent function module
  - Auto refresh settings of an intelligent function module
- To set X or Y as a refresh device, set a number later than the I/O numbers used for I/O modules and an intelligent function module.

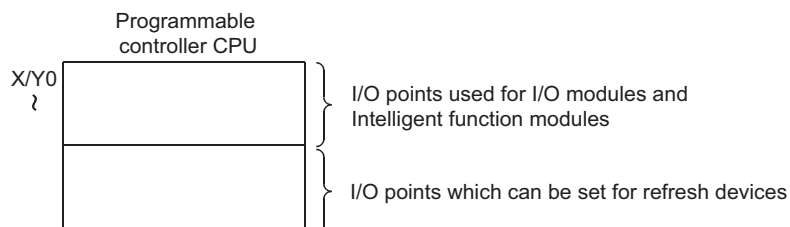

12.3 When Remote Net Additional Mode is Used  
12.3.3 Setting the local station parameters

**(b) Operation setting**

Set the operation setting as follows.

**Operation Setting Module 1**

Parameter Name:

Number of Occupied Stations: Occupied Stations 4

Data Link Faulty Station Setting:  Hold Input Data

Expanded Cyclic Setting: Single

Case of CPU STOP Setting:  Clears Compulsorily

Block Data Assurance per Station:  Enable Setting

Auto Detect: Setting of the Connected Device  
Please select Read Model Name of Slave Station in Auto Detection of the connected device.  
The start of data link may be slow after selecting the item.  
 Read Model Name of Slave Station

OK Cancel



**(2) Setting the parameters of the Ver.2 compatible local station (station number 5)**

**(a) Setting the network parameters and automatic refresh parameters**

Set the network parameters and automatic refresh parameters as follows.

For the operation setting, refer to  Page 316, Section 12.3.3 (2) (b).

	1
Start I/O No.	0000
Operation Setting	Operation Setting
Type	Local Station
Station No.	5
Master Station Data Link Type	
Mode	Remote Net(Additional Mode)
Transmission Speed	Auto Following
Total Module Connected	
Remote Input(RX)	X1000
Remote Output(RY)	Y1000
Remote Register(RWr)	W0
Remote Register(RWw)	W100
Ver.2 Remote Input(RX)	X1500
Ver.2 Remote Output(RY)	Y1500
Ver.2 Remote Register(RWr)	W1000
Ver.2 Remote Register(RWw)	W1500
Special Relay(SB)	S80
Special Register(SW)	SW0
Retry Count	
Automatic Reconnection Station Count	
Standby Master Station No.	
PLC Down Select	
Scan Mode Setting	
Delay Time Setting	
Station Information Setting	
Remote Device Station Initial Setting	
Interrupt Setting	Interrupt Setting

← Refer to Section 12.3.3 (2) (b).

**Point**

- Do not set the same refresh devices as the following.
  - Refresh parameters of modules on the network
  - I/O numbers used for I/O modules and an intelligent function module
  - Auto refresh settings of an intelligent function module
- To set X or Y as a refresh device, set a number later than the I/O numbers used for I/O modules and an intelligent function module.

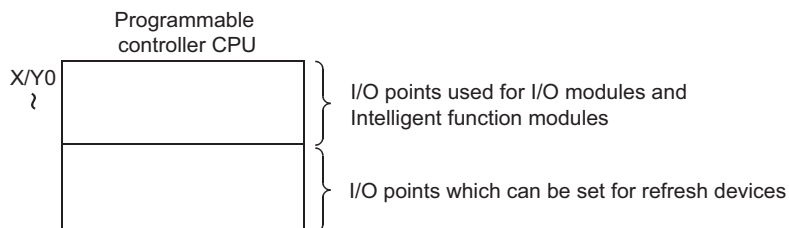

12.3 When Remote Net Additional Mode is Used  
12.3.3 Setting the local station parameters

**(b) Operation setting**

Set the operation setting as follows.

Operation Setting Module 1

Parameter Name:

Number of Occupied Stations: Occupied Stations 2

Data Link Faulty Station Setting:  Hold Input Data

Expanded Cyclic Setting: Double

Case of CPU STOP Setting:  Clears Compulsorily

Block Data Assurance per Station:  Enable Setting

Auto Detect: Setting of the Connected Device  
Please select Read Model Name of Slave Station in Auto Detection of the connected device.  
The start of data link may be slow after selecting the item.  
 Read Model Name of Slave Station

OK Cancel

## 12.3.4 Creating a program

This section shows the program to be used for communication between the master and local stations. The following diagram shows the relationship between the devices of the master station programmable controller CPU and the devices of the local station programmable controller CPU. The shaded areas indicate the devices that are actually used.

[Remote input (RX) and remote output (RY)]

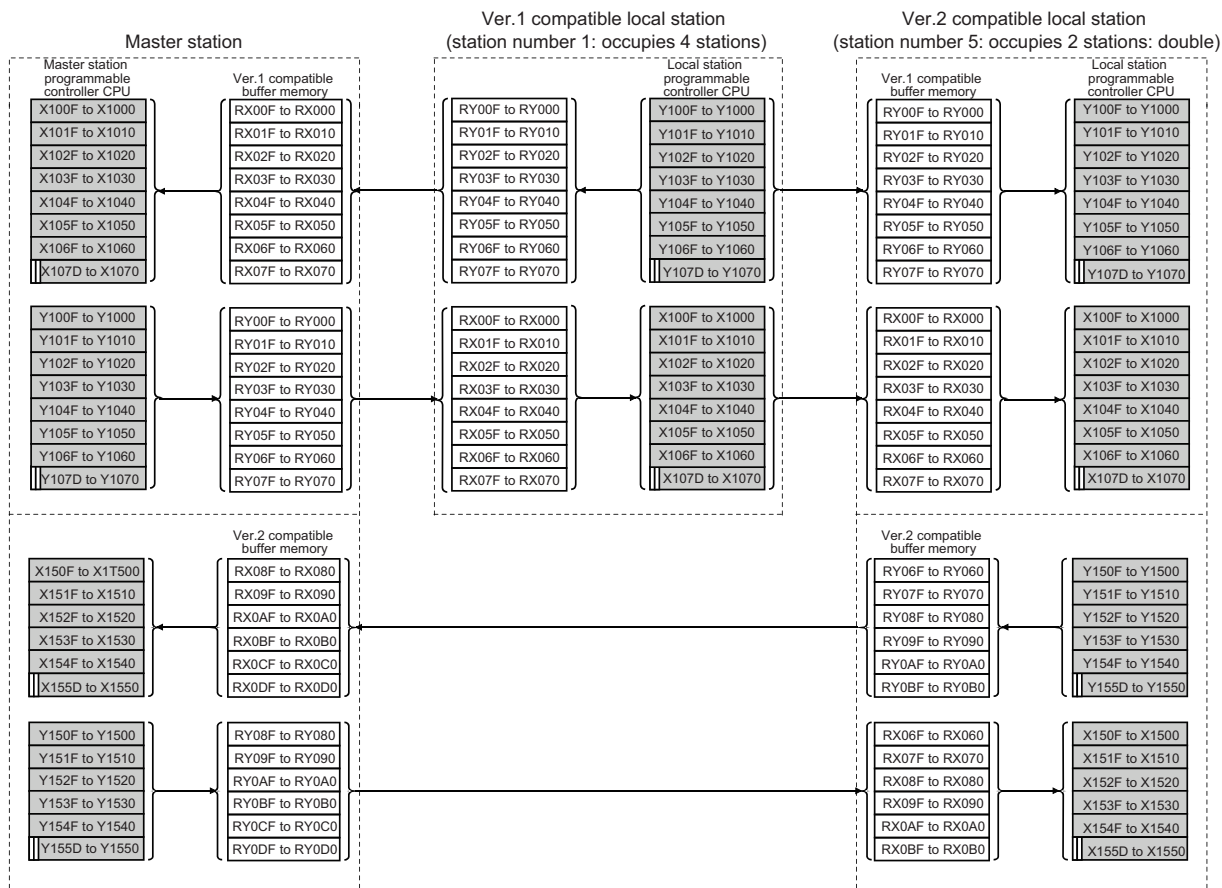

□ ..... The last two bits cannot be used for communication between the master and local stations.

[Remote registers (RWw and RWr)]

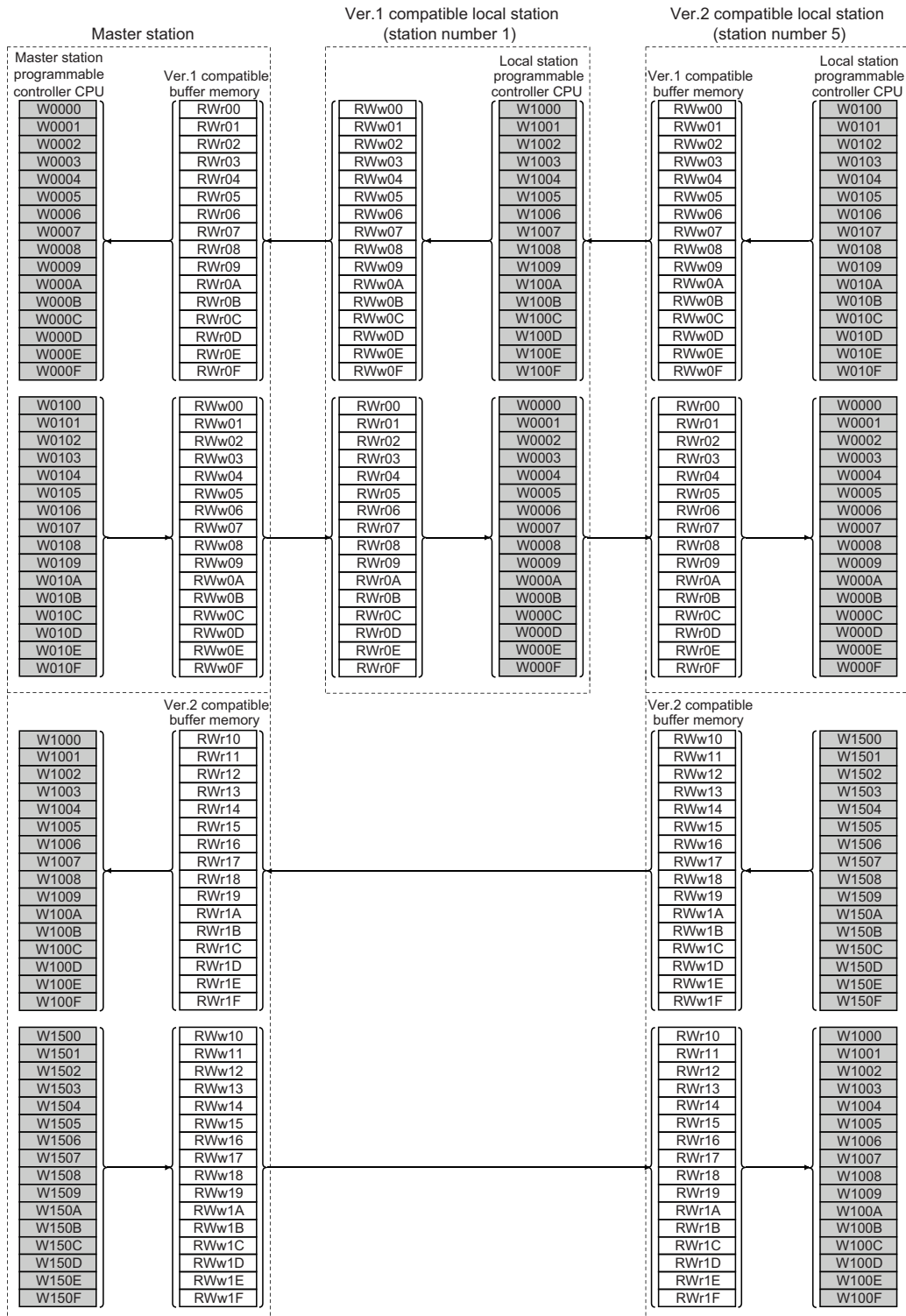

### (1) Master station program

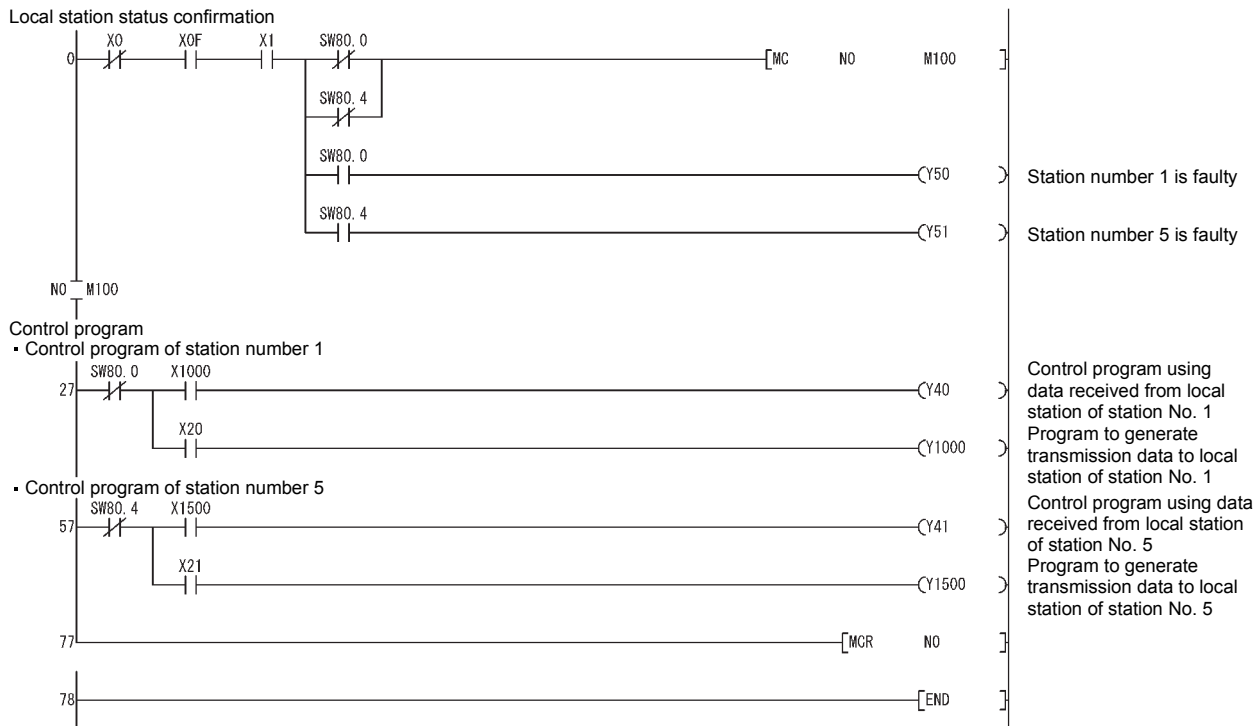

### (2) Local station program

#### (a) Ver.1 compatible local station (station number 1) program

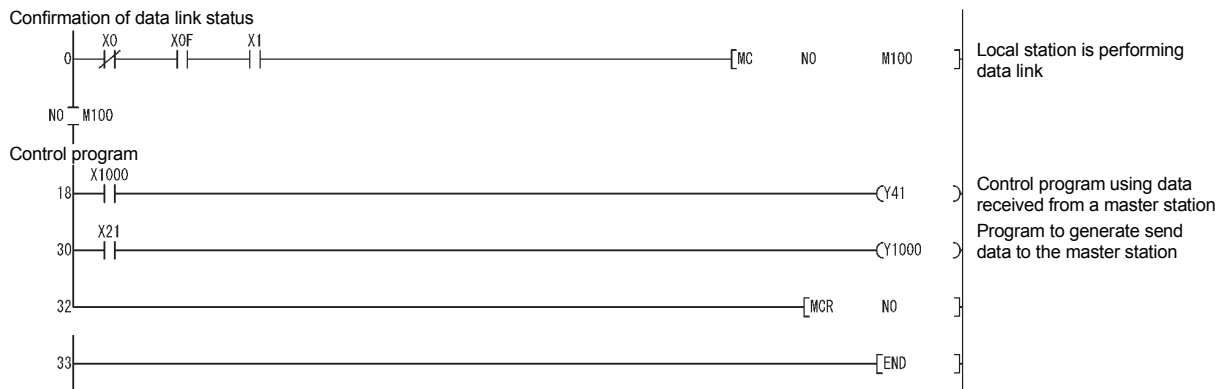

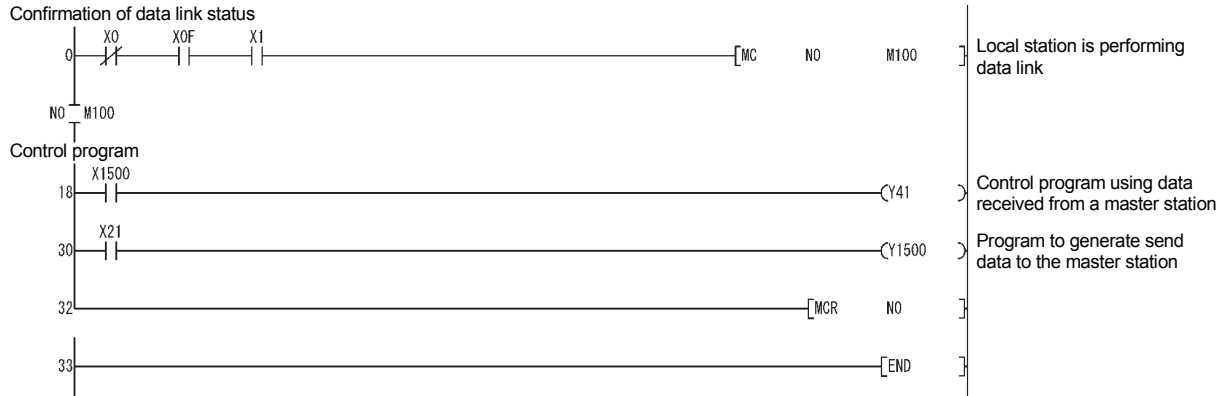

**(b) Ver.2 compatible local station (station number 5) program**



**Remark**

By enabling "Block Data Assurance per Station", the consistency of the cyclic data for each slave station can be guaranteed.

(Refer to  Page 159, Section 8.2.9)

Also, to configure an interlock in the program, refer to REMARK in  Page 291, Section 12.1.4.

## 12.3.5 Performing the data link

Turn on the local stations first, and then the master station to start the data link.

### (1) Confirming the operation with the LED indicators

The following diagram shows the LED status of the master station and the local station when the data link is being performed normally.

#### (a) LED indication of the master station

Make sure that the LEDs are as follows:

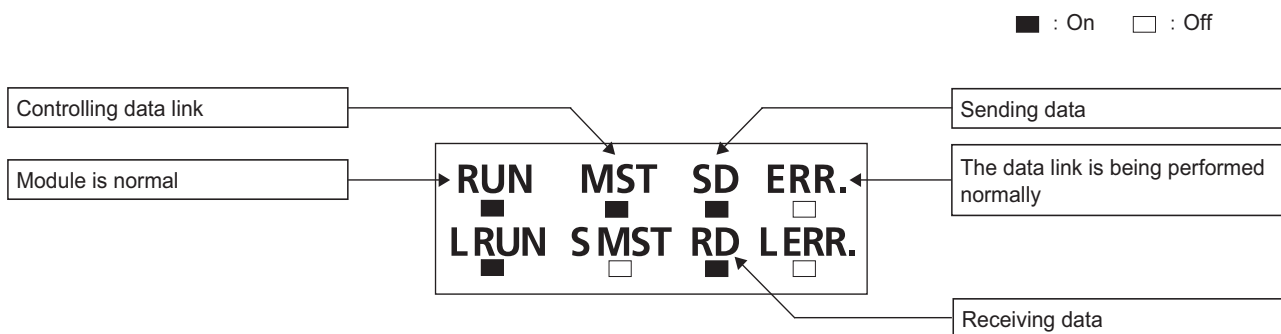

#### (b) LED indication of the local station

Make sure that the LEDs are as follows:

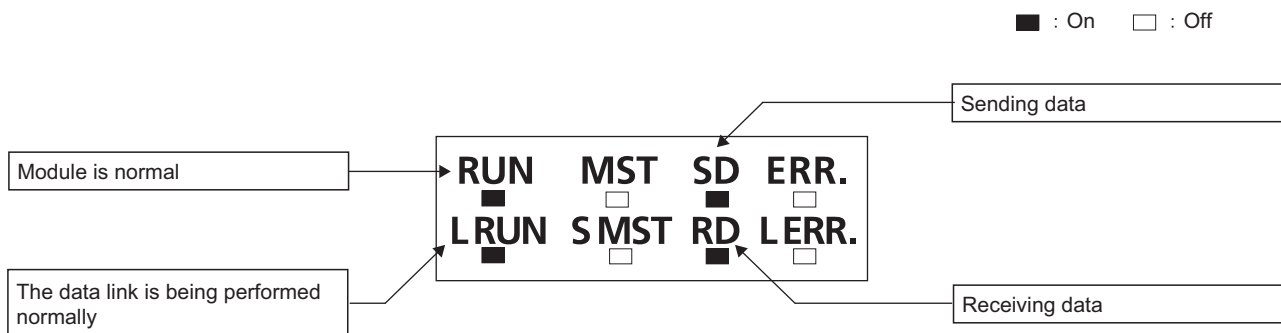

## (2) Confirming the operation with the program

Using the program, confirm that the data link is being performed normally.

- When X20 of the master station is turned on, Y41 of local station No. 1 turns on.
- When X21 of local station No. 1 is turned on, Y40 of the master station turns on.
- When X21 of the master station is turned on, Y41 of local station No. 5 turns on.
- When X21 of local station No. 5 is turned on, Y41 of the master station turns on.

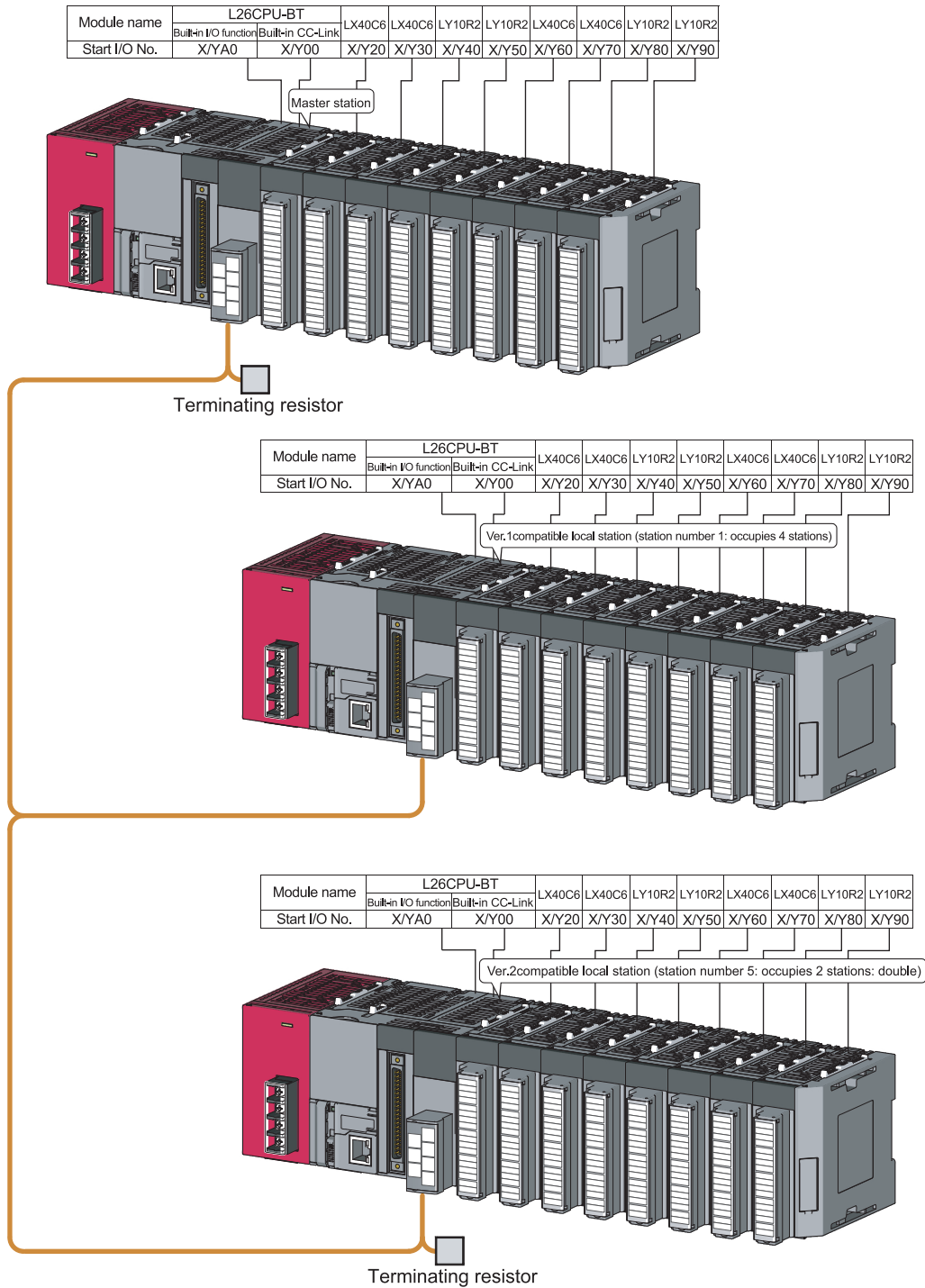



# CHAPTER 13 COMMUNICATION BETWEEN THE MASTER STATION AND INTELLIGENT DEVICE STATIONS

---

The method for communication between the master and intelligent device stations varies by intelligent device station. For more details, refer to the manual for each intelligent device station.

# Memo

---

# CHAPTER 14 EXAMPLE OF COMMUNICATION WHEN USING THE HEAD MODULE

This chapter explains the parameter settings and programming using a system configuration example.

For the parameter settings on the head module and details of cyclic transmission, refer to the following manual.

 MELSEC-L CC-Link IE Field Network Head Module User's Manual

## 14.1 System Configuration Example

The following shows a system configuration example of connecting the LJ61BT11 to the head module.

The LJ61BT11 communicates with the CC-Link slave station (AJ65BT-64AD) via CC-Link IE field network and by CC-Link cyclic transmission.

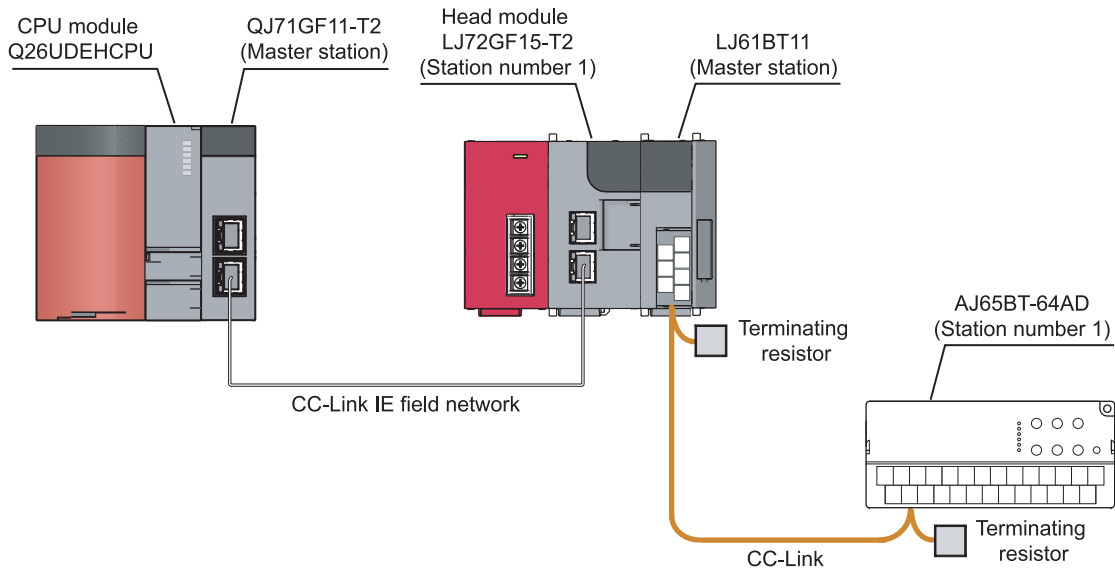

# 14.2 Image of Link Scan and Link Refresh by Cyclic Transmission

The following shows a transmission image of link device remote input RX, remote output RY, and the remote registers RWr and RWw.

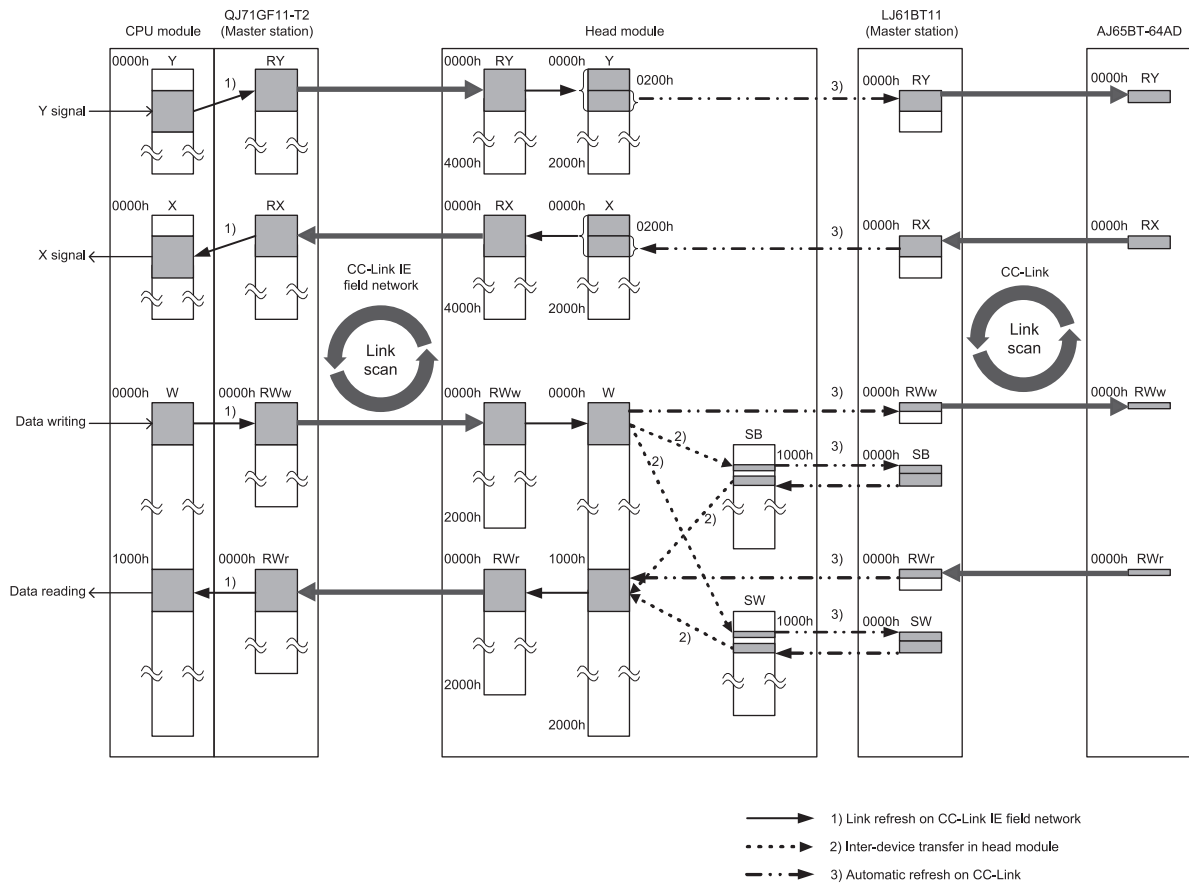

- 1) Configure the link refresh of CC-Link IE Field Network in "Refresh Parameters" in Network Parameter of the CC-Link IE Field Network master station. (Refer to Page 328, Section 14.3.1 (3).)
- 2) Configure the inter-device transfer settings of the head module by selecting "PLC Parameter" - "Operation Setting" in the head module. (Refer to Page 330, Section 14.3.2 (2).)
- 3) Configure the CC-Link automatic refresh in Network Parameter of LJ61BT11, which is connected on the head module. (Refer to Page 331, Section 14.3.2 (3).)

The head module link devices (RX/RY/RWr/RWw) are assigned as follows.

- Remote input (RX): Assigned from input (X0).
- Remote output (RY): Assigned from output (Y0).
- Remote register (RWr): Assigned from link register (W1000).
- Remote register (RWw): Assigned from link register (W0).

## 14.3 Parameter Settings



### 14.3.1 Setting parameters of the CC-Link IE Field Network master station

Set the parameters so that the CC-Link master station link special relay/register (SB/SW) is applied to the link refresh of CC-Link IE Field Network.

By setting the parameters, the access to CC-Link master station link special relay/register (SB/SW) from the master station on the CC-Link IE Field Network becomes available.

#### (1) Setting the network parameters

Set the network parameters as follows, using GX Works2.

For the "Network Configuration Setting", refer to  Page 328, Section 14.3.1 (2). For the "Refresh Parameters", refer to  Page 328, Section 14.3.1 (3).

	Module 1	Module 2
Network Type	CC IE Field (Master Station) ▼	None ▼
Start I/O No.	0000	
Network No.	1	
Total Stations	1	
Group No.		
Station No.	0	
Mode	Online (Normal Mode) ▼	▼
	Network Configuration Setting	
	Network Operation Setting	
	Refresh Parameters	
	Interrupt Setting	
	Specify Station No. by Parameter ▼	

← Refer to Section 14.3.1 (2).

← Refer to Section 14.3.1 (3).

## (2) Setting the network configuration

Set "Network Configuration Setting" in Network Parameter as follows.

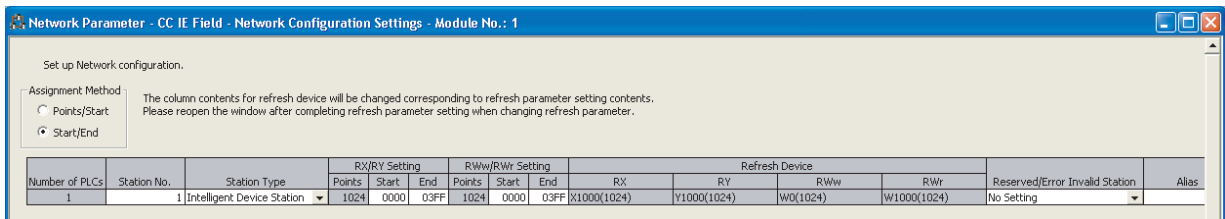

## (3) Setting the refresh parameters

Set "Refresh Parameters" in Network Parameter as follows.

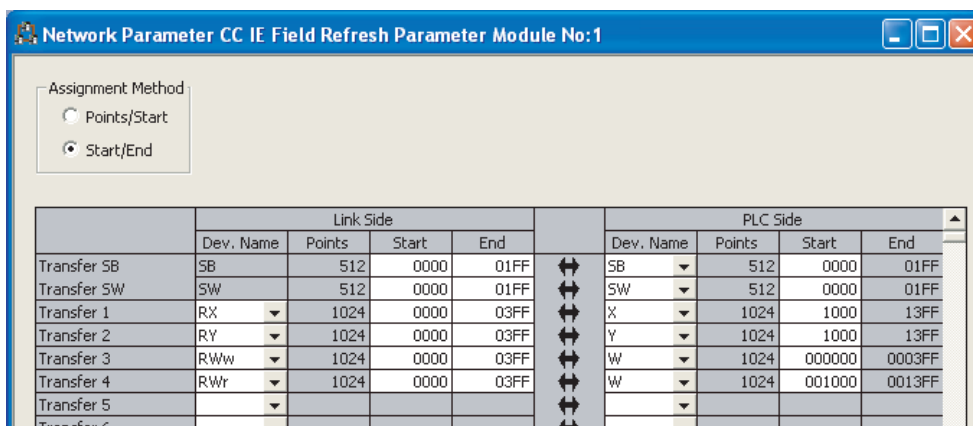

## 14.3.2 Setting parameters of the head module

Data of the CC-Link remote register (RWw/RWr) and link special relay/register (SB/SW) are exchanged by using the CC-Link IE Field Network remote register (RWw/RWr).

### (1) Communication Head Setting in PLC parameter

Select "PLC Parameter" - "Communication Head Setting", and set as follows.

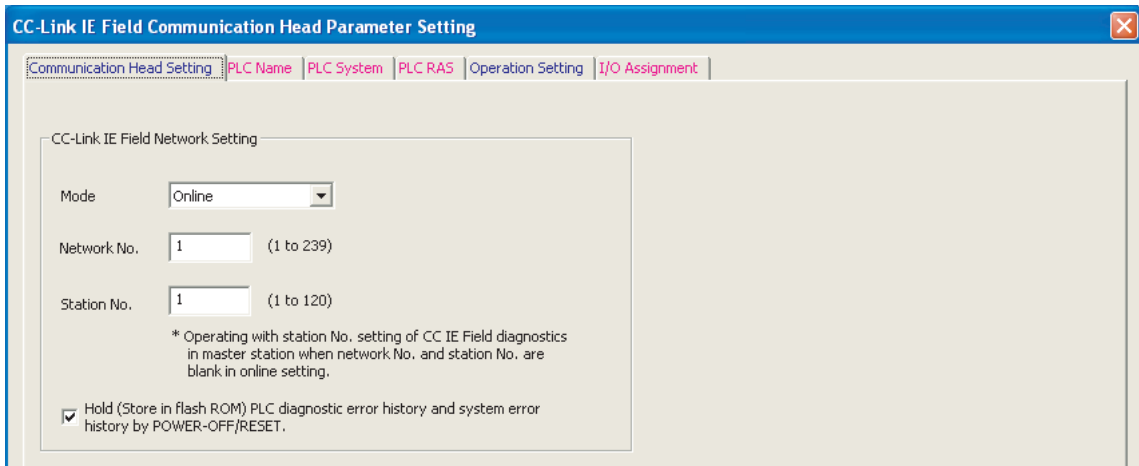

CC-Link IE Field Communication Head Parameter Setting

Communication Head Setting | PLC Name | PLC System | PLC RAS | Operation Setting | I/O Assignment

CC-Link IE Field Network Setting

Mode: Online

Network No.: 1 (1 to 239)

Station No.: 1 (1 to 120)

\* Operating with station No. setting of CC IE Field diagnostics in master station when network No. and station No. are blank in online setting.

Hold (Store in flash ROM) PLC diagnostic error history and system error history by POWER-OFF/RESET.

## (2) Operation Setting in PLC Parameter

Select "PLC Parameter" - "Operation Setting", and set as follows.

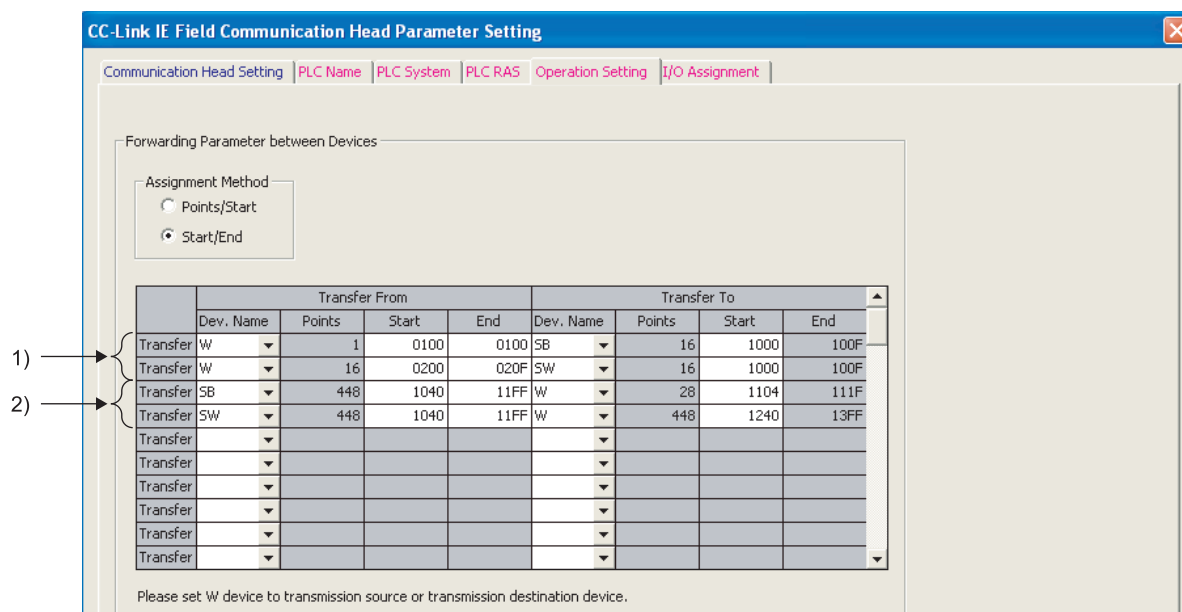

There are two directions for the link special relay/register (SB/SW) of the head module: the writing direction and the reading direction.

- 1) When writing to link special relay/register (SB/SW), set the following transfer destination.
  - Link special relay: SB1000 to SB100F
  - Link special register: SW1000 to SW100F
- 2) When reading from link special relay/register (SB/SW), set the following transfer origin.
  - Link special relay: SB1040 to SB11FF
  - Link special register: SW1040 to SW11FF

The setting example above shows the following transfer.

Head module side Link special relay/register (SB/SW)	Direction	CC-Link side Link special relay/register (SB/SW)
SB1000 to SB100F	→	SB0000 to SB000F
SW1000 to SW100F		SW0000 to SW000F
SB1040 to SB11FF	←	SB0040 to SB01FF
SW1040 to SW11FF		SW0040 to SW01FF

### (a) Precautions

Do not include the following CC-Link special relay/register (SB/SW) in the setting range for inter-device transfer.

- Link special relay: SB0010 to SB003F
- Link special register: SW0010 to SW003F



### (3) Setting network parameters for the LJ61BT11

Set the CC-Link network parameters as follows, using GX Works2.

Start I/O No.	1	0000
Operation Setting	Operation Setting	
Type	Master Station	▼
Station No.		0
Master Station Data Link Type	PLC Parameter Auto Start	
Mode	Remote Net(Ver.1 Mode)	▼
Transmission Speed	10Mbps	▼
Total Module Connected		1
Remote Input(RX)		X200
Remote Output(RY)		Y200
Remote Register(RWr)		W1000
Remote Register(RWw)		W0
Ver.2 Remote Input(RX)		
Ver.2 Remote Output(RY)		
Ver.2 Remote Register(RWr)		
Ver.2 Remote Register(RWw)		
Special Relay(SB)		SB1000
Special Register(SW)		SW1000
Retry Count		3
Automatic Reconnection Station Count		1
Standby Master Station No.		
PLC Down Select	Stop	▼
Scan Mode Setting	Asynchronous	▼
Delay Time Setting		0
Station Information Setting	Station Information	
Remote Device Station Initial Setting	Initial Setting	
Interrupt Setting		

1) → {

1) Set the "Special Relay(SB)" and "Special Register(SW)" within the following range.

- "Special Relay(SB)": SB1000 to SB1FFF
- "Special Register(SW)": SW1000 to SW1FFF

# 14.4 Program Example of CC-Link IE Field Network Master Station

## (1) Example of interlock by data link status

Configure an interlock by the data link status of the target station on the CC-Link IE Field Network.

The following shows an interlock program example by the data link status of the head module (station number 1).

Checking the head module (station number 1) data link status

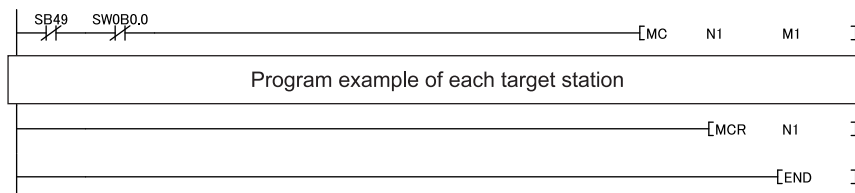

[Link special relay (SB), Link special register (SW)]

Device	Application	Device	Application
SB0049	Data link status (own station)	SW00B0.0	Data link status (each station) (station number 1)



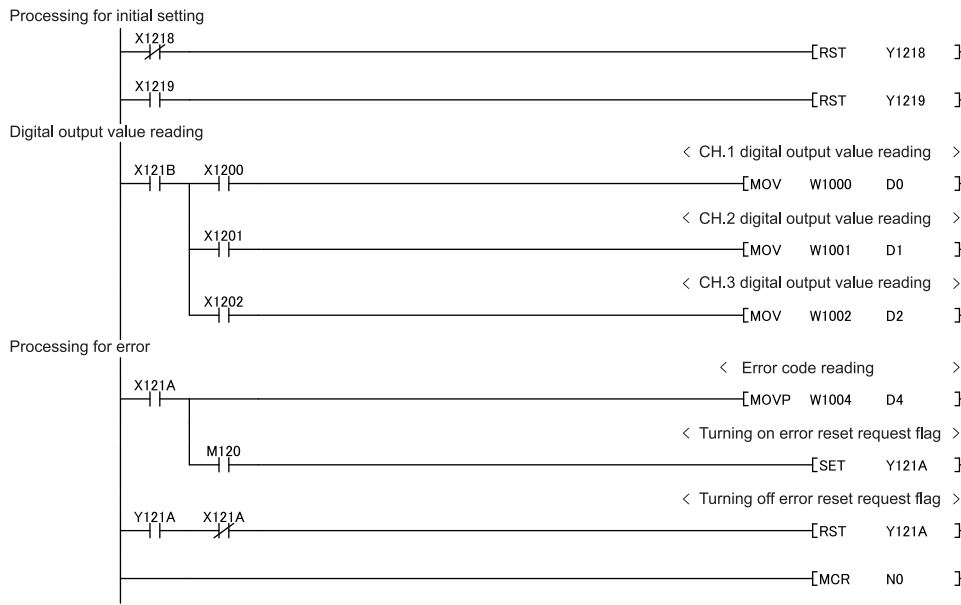

# CHAPTER 15 TROUBLESHOOTING

---



This chapter describes the details of errors that may occur in the L series master/local module and the troubleshooting. For the troubleshooting from the display unit, refer to the following manual.

 MELSEC-L CPU Module User's Manual (Hardware Design, Maintenance and Inspection)

# 15.1 Troubleshooting Procedures

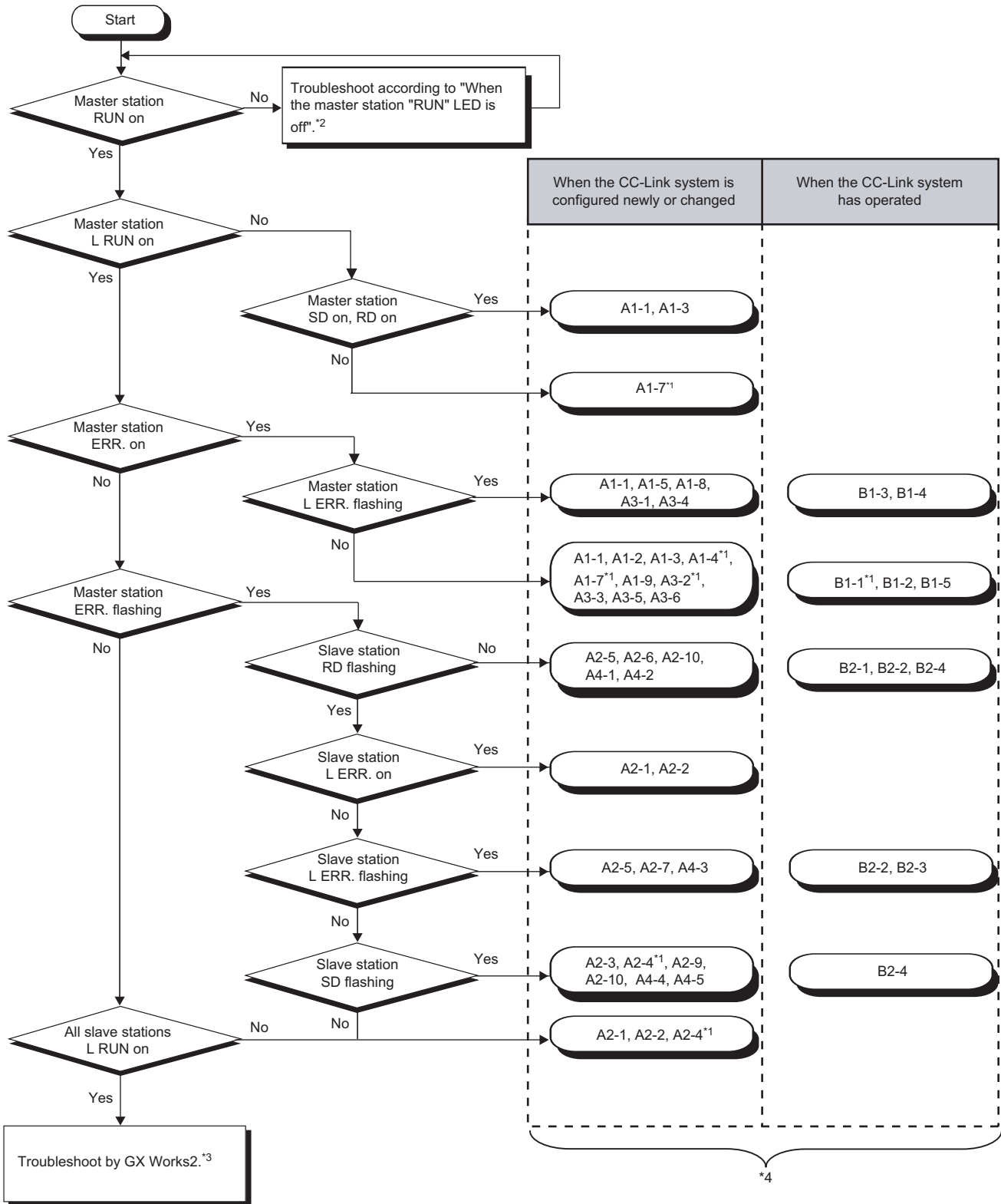
## 15.1.1 Flowcharts for troubleshooting by LEDs



- \*1 The programming tool is required to check the trouble contents.
- \*2  Page 337, Section 15.1.1 (1)
- \*3  Page 339, Section 15.1.2
- \*4 The item corresponds to the number of the check item in "When disconnecting a slave station". Refer to the corresponding check item and take the action. ( Page 345, Section 15.2.1)

**(1) When the master station "RUN" LED is off**

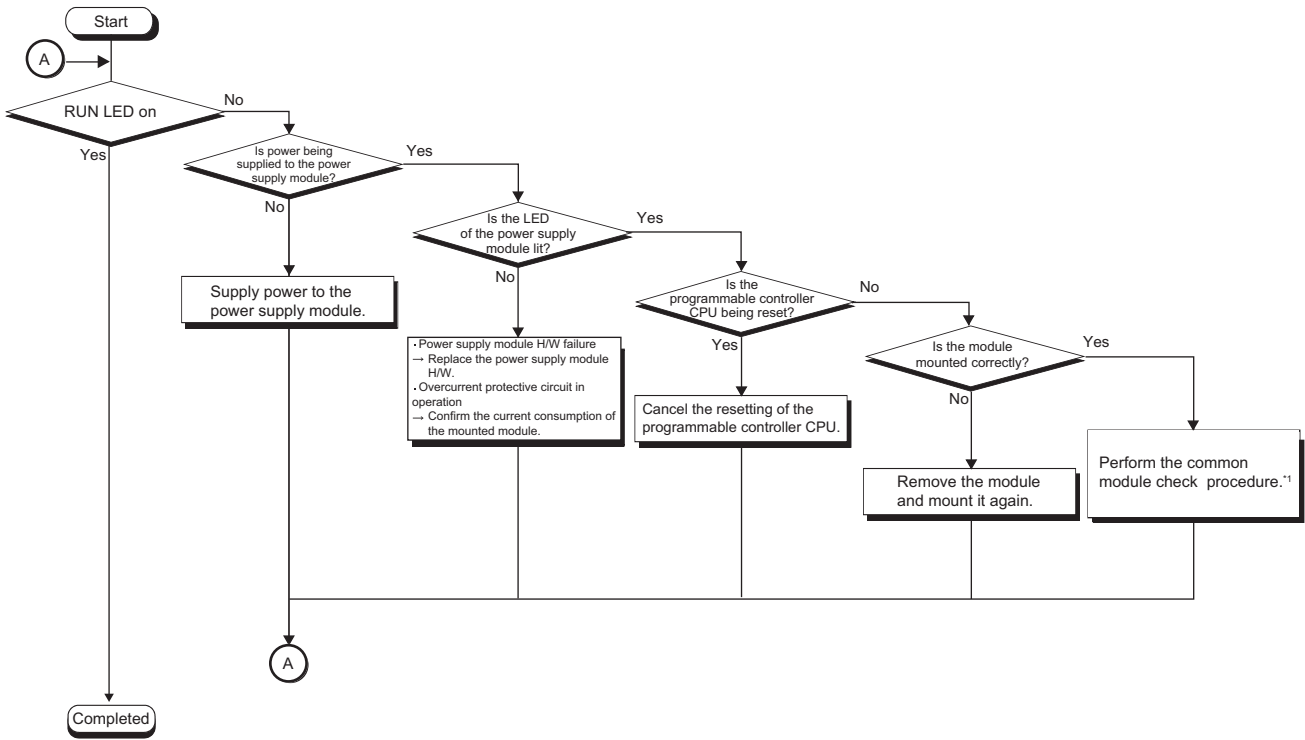

\*1  Page 338, Section 15.1.1 (2)

## (2) Common module check procedure

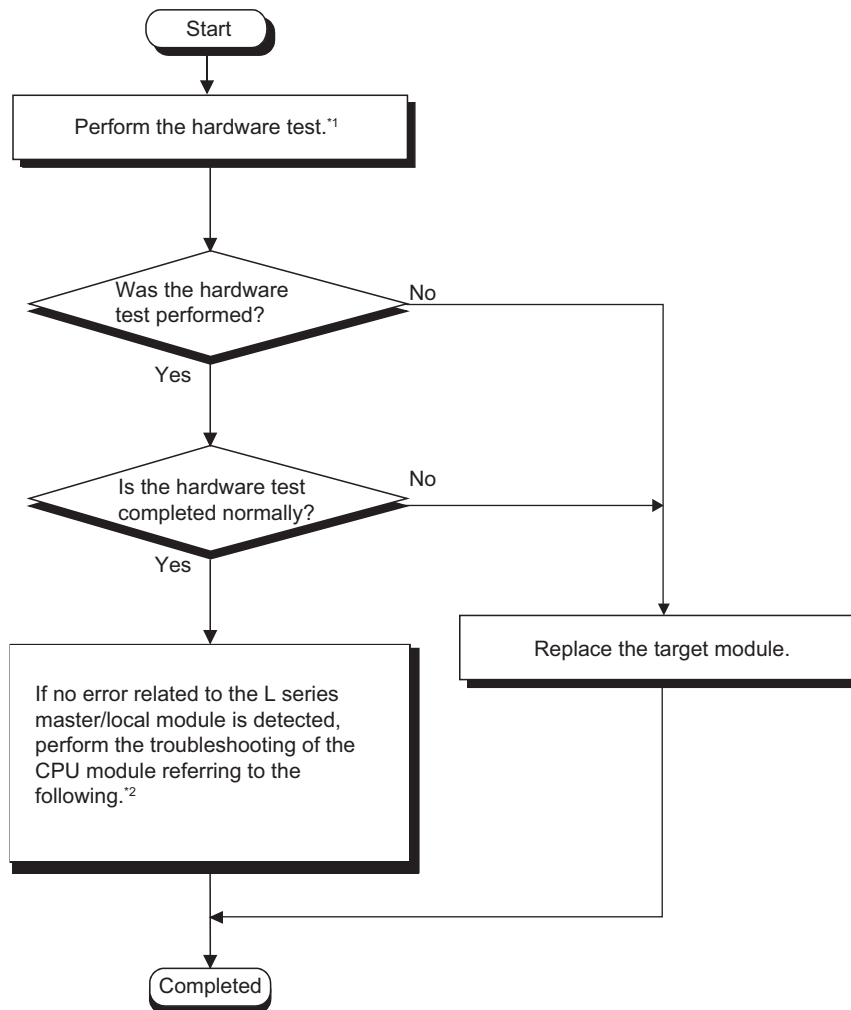

\*1  Page 60, Section 6.2

\*2  MELSEC-L CPU Module User's Manual (Hardware Design, Maintenance and Inspection)



# 15.1.2 Flowcharts for troubleshooting by GX Works2

## (1) Troubleshooting by CC-Link diagnostics

Connect GX Works2 to the master station and execute the CC-Link diagnostics.

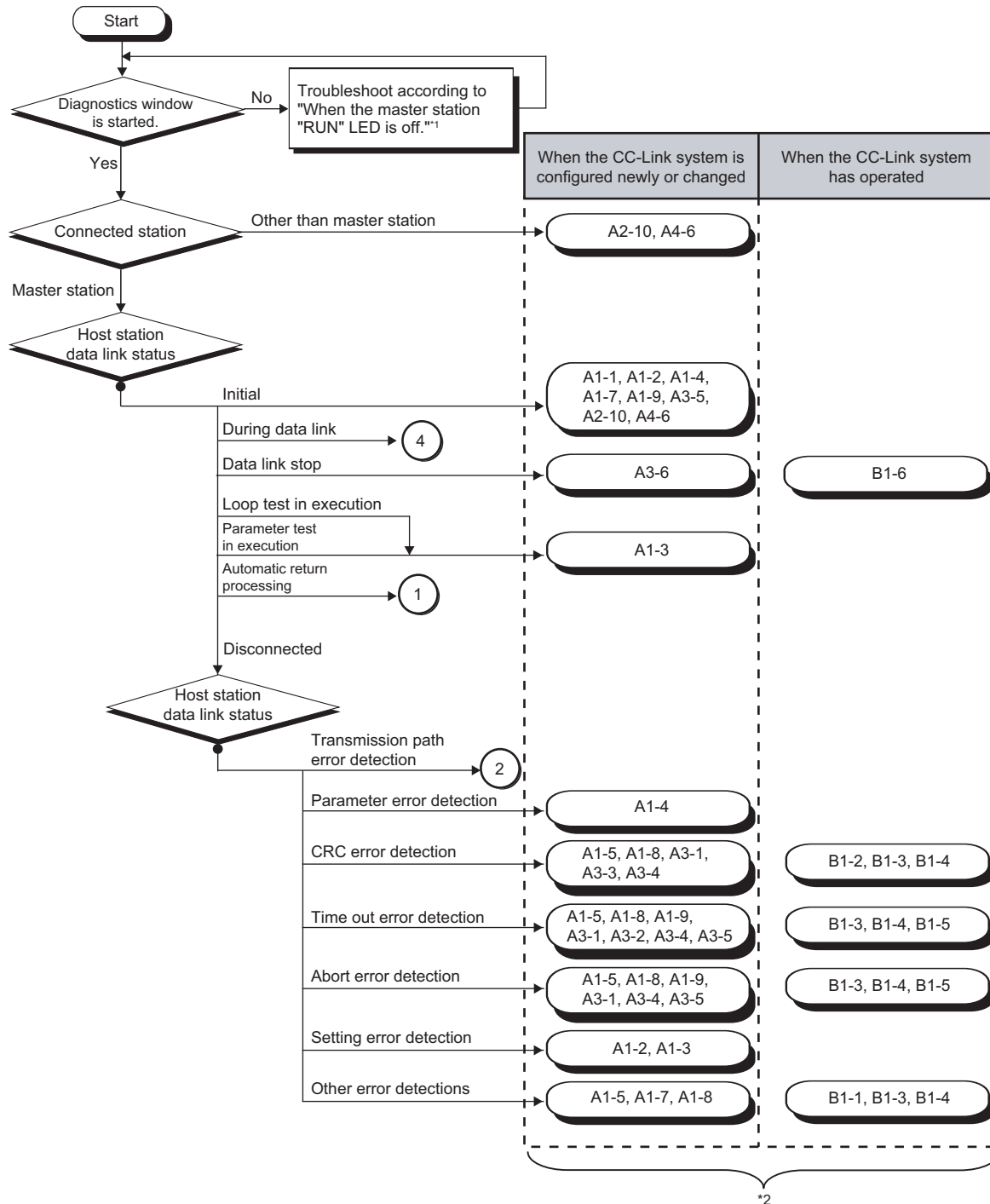

\*1 Page 337, Section 15.1.1 (1)

\*2 The item corresponds to the number of the check item in "When disconnecting a slave station". Refer to the corresponding check item and take the action. ( Page 345, Section 15.2.1)

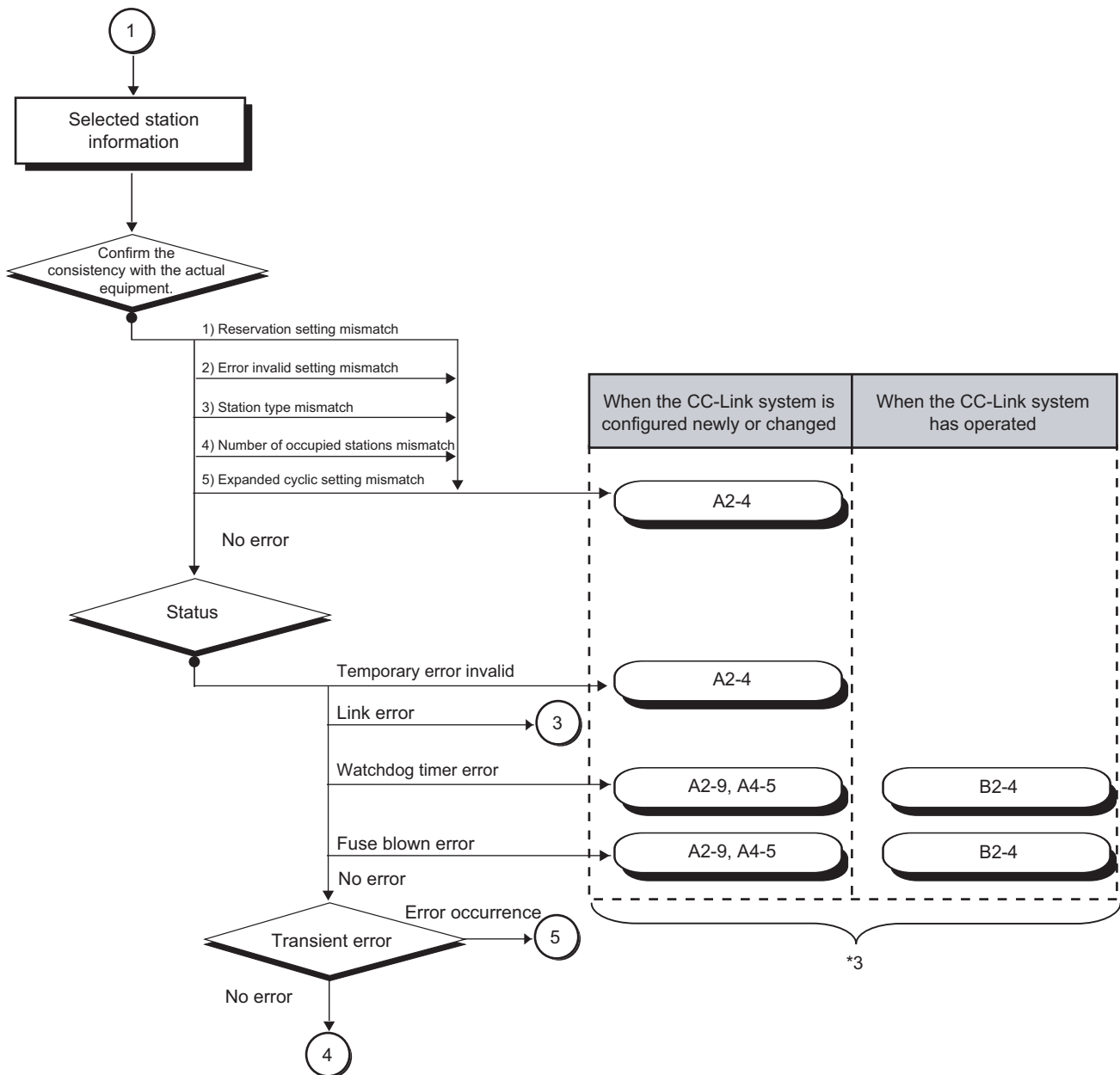



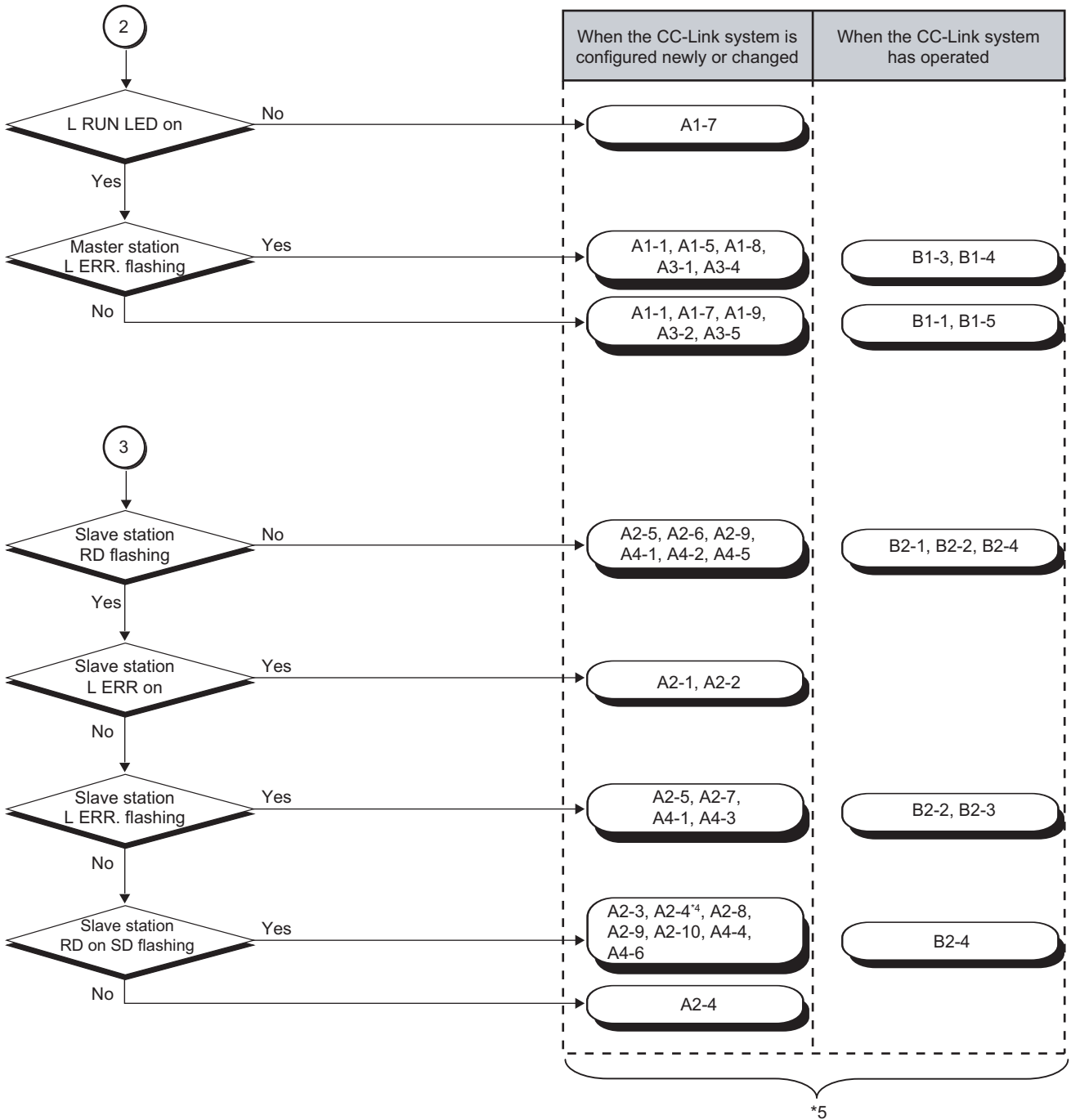

\*3 The item corresponds to the number of the check item in "When disconnecting a slave station". Refer to the corresponding check item and take the action. (Page 345, Section 15.2.1)

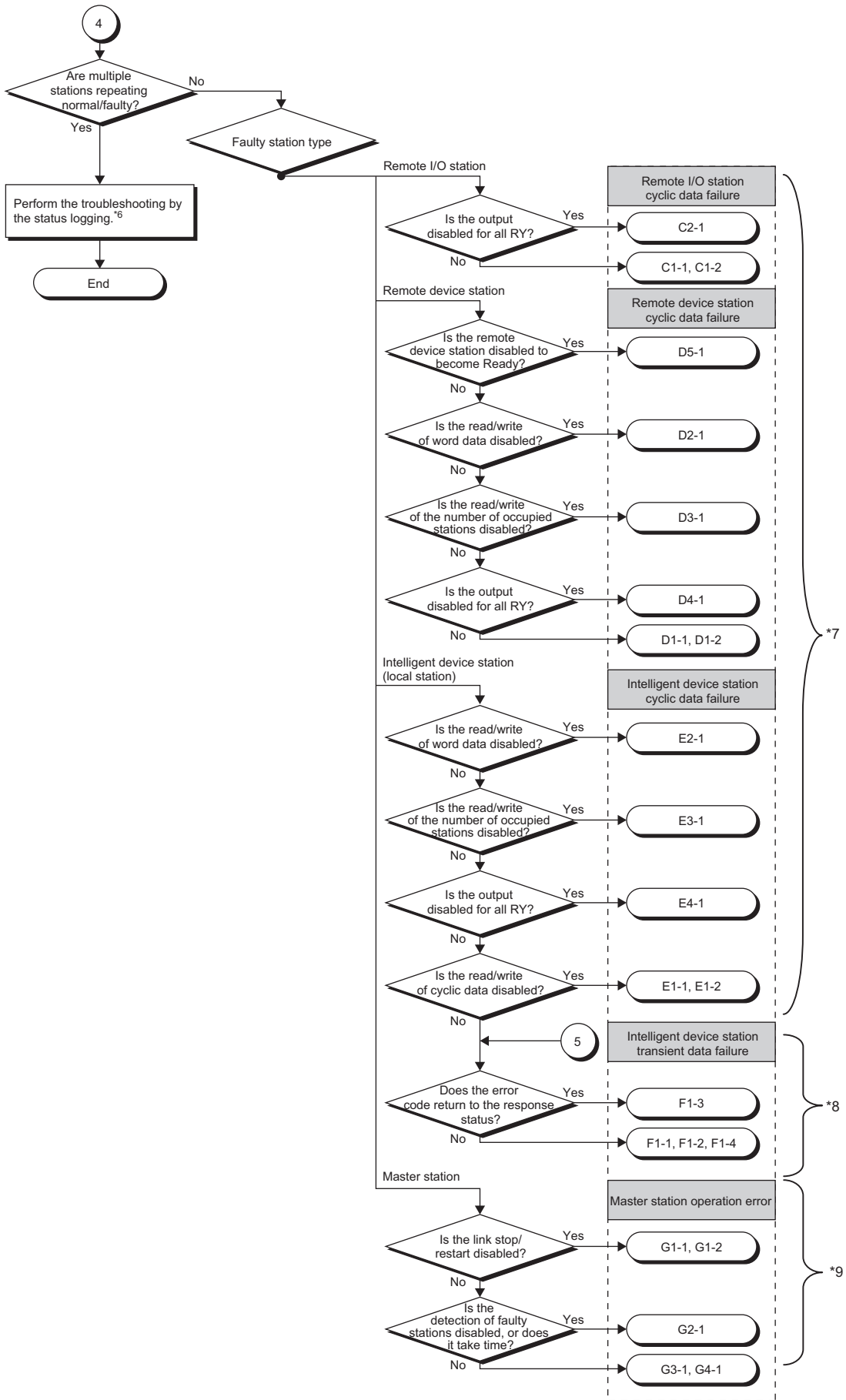

\*4 The programming tool is required to check the trouble contents.

\*5 The item corresponds to the number of the check item in "When disconnecting a slave station". Refer to the corresponding check item and take the action. (Page 345, Section 15.2.1)



- \*6  Page 344, Section 15.1.2 (2)
- \*7 The item corresponds to the number of the check item in "When cyclic data are faulty". Refer to the corresponding check item and take the action. ( Page 353, Section 15.2.2)
- \*8 The item corresponds to the number of the check item in "When transient data are faulty". Refer to the corresponding check item and take the action. ( Page 356, Section 15.2.3)
- \*9 The item corresponds to the number of the check item in "When operation of the master station is faulty". Refer to the corresponding check item and take the action. ( Page 357, Section 15.2.4)

## (2) Troubleshooting by status logging

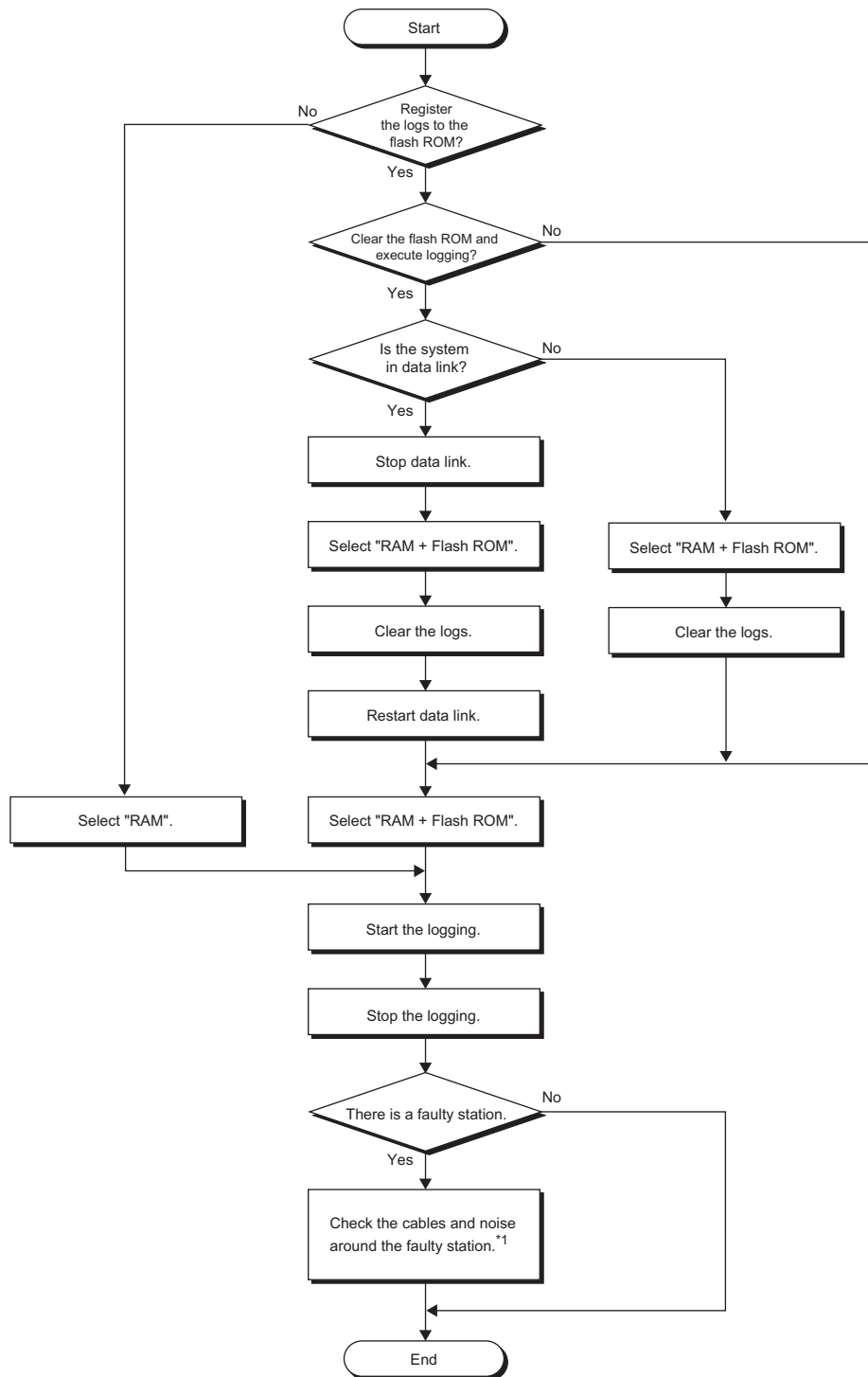

\*1  Page 351, Section 15.2.1 (2)

## 15.2 List of Problems

### 15.2.1 When disconnecting a slave station

#### (1) Problems on slave station disconnection (when creating a new CC-Link system or modifying the existing system)

Description of problem	Check item		Check contents	Check procedure	Corrective action
Unable to link the entire system.	A1-1	Station No.	Is the station number setting at the faulty station correct?	Check the station number setting at the corresponding station.	Set the station number properly.
	A1-2	Transmission speed	Is the setting within the transmission speed setting range? Do the settings of the master station and slave stations differ from each other?	Check the setting of the transmission speed for each station.	Set the transmission speed properly.
	A1-3	Mode	Is the master station in other than online mode?	Check the mode setting of the master station.	Set the online mode.
	A1-4	Parameter setting	<ul style="list-style-type: none"> <li>• Are the network parameters (such as unit number or station information) correct?</li> <li>• Is some error occurring at the master station?</li> <li>• Network parameter of the GX Works2</li> </ul>	Check the contents of the network parameters for the programmable controller CPU of the master station. Check the station number (SW0061), transmission speed (SW005B) and mode (SW0060) settings. Check SW0068, SW0069, SW0070, SW0071, SW0072, SW0074 to SW0077, SW0098 to SW009B, SW009C to SW009F, and SW0144 to SW0147.	Set the network parameter properly. Execute the memory format of the programmable controller CPU and then write the network parameter.
		Is not the setting wrong? (Automatic CC-Link startup)	Check if any value is set to the intelligent function module switch setting.	Disable the intelligent function module switch settings in GX Works2.	

Description of problem	Check item		Check contents	Check procedure	Corrective action
Unable to link the entire system.	A1-5	Cables	Is there any disconnection, short-circuit, incorrect wiring, faulty connection, or status out of specifications (transmission distance, distance between stations, transmission cable, coexistence of different cables or FG connection)?	Check if the cable between the master station and slave station is not disconnected.	Connect the cable properly.
			Are the terminating resistors connected?	Check if the terminating resistors are connected to the both ends of the CC-Link system. Check if a station with built-in terminating resistor is connected other than at both ends in the CC-Link system.	Connect the terminating resistors to the both ends of the CC-Link system.
	A1-6	Link start	Is the programmable controller CPU in the RESET status? (when setting the network parameter)	Check if the RESET switch of the programmable controller CPU is not at the RESET position.	Set the RESET switch to the center position.
			Does CC-Link startup automatically?	Check if any value is set to the intelligent function module switch setting.	Disable the intelligent function module switch settings in GX Works2.
	A1-7	Programmable controller CPU check	Does any error occur at the programmable controller CPU of the master station?	Check the error code of the programmable controller CPU.	Correct the error code of the programmable controller CPU. Refer to MELSEC-L CPU Module User's Manual (Hardware Design, Maintenance and Inspection)
				Check if the module can be recognized.	Recognize the L series master/local module properly. Refer to MELSEC-L CPU Module User's Manual (Hardware Design, Maintenance and Inspection)
			Is not the sequence scan too long? (synchronous mode)	Does the sequence scan time exceed the tolerance? 10Mbps: 50ms 5Mbps: 50ms 2.5Mbps: 100ms 625kbps: 400ms 156kbps: 800ms	Switch to the asynchronous mode, or reduce the transmission speed.



Description of problem	Check item		Check contents	Check procedure	Corrective action
Unable to link the entire system.	A1-8	Noise	Is there any noise on the transmission cable?	Check if the transmission cable and power wiring are separated enough.	Wire the transmission cable and power wiring as separated as possible. (recommended to keep a distance of more than 100mm)
				Check if the FG is separated from the power system GND.	Set FG and the power system GND apart.
				Reduce the transmission speed and then check the occurrence frequency.	Execute the protection against noise. Reduce the transmission speed.
	A1-9	Master station failure	Is the master station failed?	Check if the system operates properly after replacing the master station.	Fix or replace the master station.
Some station(s) cannot be linked.	A2-1	Station No.	Is the station number setting at the faulty station correct?	Check the station number setting at the corresponding station.	Set the station number properly.
	A2-2	Transmission speed	Is the transmission speed at the faulty station correct?	Check the setting of the transmission speed at the corresponding station.	Correct the transmission speed.
	A2-3	Online status (slave station)	Is the CC-Link interface at the faulty station in the online status?	Check the status of the faulty station.	Set the online status.
	A2-4	Parameter setting	<ul style="list-style-type: none"> <li>• Are the network parameters (such as unit number or station information) correct?</li> <li>• Is some error occurring at the master station?</li> <li>• Network parameter of the GX Works2</li> </ul>	Check the contents of the network parameters for the programmable controller CPU of the master station. Check SW0068, SW0069, SW0070, SW0071, SW0072, SW0074 to SW0077, SW0098 to SW009B, SW009C to SW009F, and SW0144 to SW0147.	Set the network parameter properly. Execute the memory format of the programmable controller CPU and then write the network parameter.
Is the setting correct? (Automatic CC-Link startup)			Check if any value is set to the intelligent function module switch setting.	Disable the intelligent function module switch settings in GX Works2.	

Description of problem	Check item		Check contents	Check procedure	Corrective action
Some station(s) cannot be linked.	A2-5	Cables	Is there any disconnection, short-circuit, incorrect wiring, faulty connection, or status out of specifications (transmission distance, distance between stations, transmission cable, coexistence of different cables or FG connection)?	Check if the SD LED and RD LED are flashing at the faulty station.	Connect the cable properly.
			Are the terminating resistors connected?	Check the cable of the closest faulty station from the master station, when multiple stations are sequentially faulty to the terminal of the transmission path. (multiple stations)	Connect the cable properly.
				Check if the terminating resistors are connected to the both ends of the CC-Link system.	Connect the terminating resistors to the both ends of the CC-Link system.
	A2-6	Power supply (for communication)	Is the power off or out of the range of use?	Check if a station with built-in terminating resistor is connected other than at both ends in the CC-Link system.	
				Is the power on at the faulty station?	Turn the power supply on.
	A2-7	Noise	Is there any noise on the transmission cable?	Is the supplied power within the specified range?	Set the supplied voltage to within the specified range.
				Check if the transmission cable and power wiring are separated enough.	Wire the transmission cable and power wiring as separated as possible. (recommended to keep a distance of more than 100mm)
				Check if the FG is separated from the power system GND.	Set FG and the power system GND apart.
	A2-9	Slave station failure	Is the slave station failed?	Reduce the transmission speed and then check the occurrence frequency.	Take measures against noise. Reduce the transmission speed.
				Replace the failed station and check the operation.	Fix or replace the failed slave station.
A2-10	Standby master station	Is the standby master station controlling the data link?	Check if the master station switching status is in the standby master station, with the master station CC-Link diagnostics.	Reboot the system and set the control by the master station.	

Description of problem	Check item		Check contents	Check procedure	Corrective action
Unable to link the entire system occasionally.	A3-1	Cables	Is there any cable/connector disconnected or out of specifications?	Check the cable between the master station and slave station.	Connect the corresponding cable properly.
	A3-2	Parameter setting	Is not the sequence scan too long? (synchronous mode)	Does the sequence scan time exceed the tolerance? 10Mbps: 50ms 5Mbps: 50ms 2.5Mbps: 100ms 625kbps: 400ms 156kbps: 800ms	Switch to the asynchronous mode, or reduce the transmission speed.
	A3-3	Power supply (for communication)	Is the power off or out of the range of use?	Check the power supply of the master station and all slave stations.	Set the supplied voltage to within the specified range.
	A3-4	Noise	Is there any noise on the transmission cable?	Check if the transmission cable and power wiring are separated enough.	Wire the transmission cable and power wiring as separated as possible. (recommended to keep a distance of more than 100mm)
				Check if the FG is separated from the power system GND.	Set FG and the power system GND apart.
				Reduce the transmission speed and then check the occurrence frequency.	Take measures against noise. Reduce the transmission speed.
	A3-5	Master station failure	Is the master station failed?	Check if the system operates properly after replacing the master station.	Fix or replace the master station.
A3-6	Link stop	Is the data link stop instruction being executed properly?	Check if the data link stop (SB0002) is turned on.	Disable the data link stop (SB0002). Do not use devices which read SB002 simultaneously.	
Some station(s) cannot be linked occasionally.	A4-1	Cables	Is there any disconnection, short-circuit, incorrect wiring, faulty connection, or status out of specifications (transmission distance, distance between stations, transmission cable, coexistence of different cables or FG connection)?	Check the cable at the faulty station.	Connect the corresponding cable properly.
			Are the terminating resistors connected?	Check the cable of the closest faulty station from the master station, when multiple stations are sequentially faulty to the terminal of the transmission path. (multiple stations)	
				Check if the terminating resistors are connected to the both ends of the CC-Link system.	Check if a station with built-in terminating resistor is connected other than at both ends in the CC-Link system.
	A4-2	Power supply (for communication)	Is the power off or out of the range of use?	Check the power supply at the faulty station.	Set the supplied voltage to within the specified range.

Description of problem	Check item		Check contents	Check procedure	Corrective action
Some station(s) cannot be linked occasionally.	A4-3	Noise	Is there any noise on the transmission cable?	Check if the transmission cable and power wiring are separated enough.	Wire the transmission cable and power wiring as separated as possible.
				Check if the FG is separated from the power system GND.	Set FG and the power system GND apart.
				Reduce the transmission speed and then check the occurrence frequency.	Take measures against noise. Reduce the transmission speed.
	A4-4	Startup	Is the startup sequence correct?	Check by changing the startup sequence of the failure station.	Startup with the procedure described in the manual of the corresponding station.
	A4-5	Slave station failure	Is the slave station failed?	Replace the failed station and check the operation.	Fix or replace the failed slave station.
A4-6	Standby master station	Is the standby master station controlling the data link?	Check if the master station switching status is in the standby master station, with the master station CC-Link diagnostics.	Reboot the system and set the control by the master station.	

## (2) Problems on slave station disconnection (when the CC-Link system has been normally operated)

Description of problem	Check item		Check contents	Check procedure	Corrective action
Unable to link the entire system.	B1-1	Programmable controller CPU check	Does any error occur at the programmable controller CPU of the master station?	Check the error code of the programmable controller CPU.	Correct the error code of the programmable controller CPU. Refer to MELSEC-L CPU Module User's Manual (Hardware Design, Maintenance and Inspection)
				Check if the module can be recognized.	Recognize the L series master/local module properly. Refer to MELSEC-L CPU Module User's Manual (Hardware Design, Maintenance and Inspection)
	B1-2	Power supply (for communication)	Is any voltage drop occurring?	Check the power supply of the master station and all slave stations.	Set the supplied voltage to within the specified range.
	B1-3	Cables	Is there any disconnection, short-circuit or faulty connection?	Check if the cable between the master station and slave station is connected properly.	Connect the cable properly.
	B1-4	Noise	Is there any noise on the transmission cable?	Check if the transmission cable and power wiring are separated enough.	Wire the transmission cable and power wiring as separated as possible. (recommended to keep a distance of more than 100mm)
				Check if the FG is separated from the power system GND.	Set FG and the power system GND apart.
				Reduce the transmission speed and then check the occurrence frequency.	Take measures against noise. Reduce the transmission speed.
B1-5	Master station failure	Is the master station failed?	Check if the system operates properly after replacing the master station.	Fix or replace the master station.	
B1-6	Link stop	Is the data link stop instruction being executed properly?	Check if the data link stop (SB0002) is turned on.	Disable the data link stop (SB0002). Do not use devices which read SB0002 simultaneously.	

Description of problem	Check item		Check contents	Check procedure	Corrective action
A station cannot be linked occasionally.	B2-1	Power supply (for communication)	Is any voltage drop occurring?	Check the power supply at the faulty station.	Set the supplied voltage to within the specified range.
	B2-2	Cables	Is there any cable/connector disconnected or out of specifications?	Check the connection cable at the faulty station.	Connect the corresponding cable properly.
				Check the cable of the closest faulty station from the master station, when multiple stations are sequentially faulty to the terminal of the transmission path.	
	B2-3	Noise	Is there any noise on the transmission cable?	Check if the transmission cable and power wiring are separated enough.	Wire the transmission cable and power wiring as separated as possible. (recommended to keep a distance of more than 100mm)
				Check if the FG is separated from the power system GND.	Set FG and the power system GND apart.
Reduce the transmission speed and then check the occurrence frequency.				Execute the protection against noise. Reduce the transmission speed.	
B2-4	Slave station failure	Is the slave station failed?	Replace the failed station and check the operation.	Fix or replace the failed slave station.	

## 15.2.2 When cyclic data are faulty

### (1) Problems on abnormal cyclic data of a remote I/O station

Description of problem	Check item		Check contents	Check procedure	Corrective action
Unable to read/write cyclic data	C1-1	Refresh data area	Is the automatic refresh set properly? (RX, RY, SB, SW)	Check if the automatic refresh setting range is correct.  Check if there is no overlapping with devices used in the program or in other networks. 32 points (fixed) per station, also for 8 or 16 points I/O modules. (except for the point setting of the remote I/O station)	Set the automatic refresh parameter properly.  Set so as not to overlap the refresh device with devices used in the program or in other networks.
			Are the refresh by the automatic refresh parameter setting and the refresh by the FROM/TO instruction executed simultaneously?	Check the program. Check the automatic refresh parameter setting.	Execute either one of the refresh by the automatic refresh parameter setting or the refresh by the FROM/TO instruction.
			Is the correct address of the buffer memory being read/written? (RX, RY, SB, SW)	Check the program. 32 points (fixed) per station, also for 8 or 16 points I/O modules. (except for the point setting of the remote I/O station)	Access the corresponding address. Set so as not to overlap the refresh device with devices used in the program or in other networks.
	C1-2	Parameter setting	Is there any fault in the reserved station setting?	Check if the corresponding station bit, which is not read/written at the reserved station specified status (SW0074 to SW0077), is not "1".	Release the reserved station setting.
Unable to RY-output.	C2-1	Refresh instruction	Is the refresh instruction (SB0003) executed?	Check if the refresh instruction (SB0003) is turned on.	Turn on the refresh instruction (SB0003).

## (2) Problems on abnormal cyclic data of a remote device station

Description of problem	Check item		Check contents	Check procedure	Corrective action
Unable to read/write cyclic data	D1-1	Refresh data area	Is the automatic refresh set properly? (RX, RY, RWw, RWr, SB, SW)	Is not the area overlapped with the program or device used at other network?	Set so as not to overlap with devices used in the program or in other networks.
			Is the access to buffer memory correct? (RX, RY, RWw, RWr, SB, SW)	Check if there is no overlapping with devices used in the program or in other networks.	Access the corresponding station address. Set so as not to overlap with the device used in the program.
	D1-2	Parameter setting	Is there any fault in the reserved station setting?	Check if the reserved station is not set or the corresponding station bits (SW0074 to SW0077) are not set to "1".	Release the reserved station setting.
Unable to read/write word data	D2-1	Parameter setting	Is there any fault in the consistency with the parameter?	Check if any remote I/O station is installed to the corresponding station number.	Combine the parameter and the installed model.
Unable to read/write the lower area of the cyclic data.	D3-1	Parameter setting	Is there any fault in the consistency with the parameter?	Check if any device, which number of occupied stations is small, is installed to the corresponding station number.	Combine the number of occupied stations of the parameter and installed model.
Unable to RY-output.	D4-1	Refresh instruction	Is the refresh instruction (SB0003) executed?	Check if the refresh instruction (SB0003) is turned on.	Turn on the refresh instruction (SB0003).
Unable to turn the remote device station to Ready (Xn1B: ON).	D5-1	Initial setting	Is the initial setting (Xn18) completed?	Check if the initial data processing request (Xn18) is turned off.	Execute the initial data processing.
			Is the remote device station initialize procedure registration completed normally?	Check if the remote device station initialize procedure registration (SB000D) is turned on. Check the result of the remote device station initialize procedure registration instruction.	Review the remote device station initialize procedure registration.
			Is there any fault in the remote device station initial setting?	Check the parameter. Check the program.	Set the remote device station initial setting properly.



### (3) Problems on abnormal cyclic data of an intelligent device station (local station)

Description of problem	Check item		Check contents	Check procedure	Corrective action
Unable to read/write cyclic data	E1-1	Refresh data area	Is the automatic refresh set properly? (RX, RY, RWw, RWr, SB, SW)	Check if there is no overlapping with devices used in the program or in other networks.	Set so as not to overlap with devices used in the program or in other networks.
			Is the access to buffer memory correct? (RX, RY, RWw, RWr, SB, SW)	Check if there is no overlapping with devices used in the program or in other networks, in the master station.	Access the corresponding address of the master station. Set so as not to overlap with the device used in the program.
				Check if there is no overlapping with devices used in the program or in other networks, in local stations.	Access the normal address at the local station side. Set so as not to overlap with the device used in the program.
	E1-2	Parameter setting	Is there any fault in the reserved station setting?	Check if the reserved station is not set or the corresponding station bits (SW0074 to SW0077) are not set to "1".	Release the reserved station setting.
Unable to read/write word data	E2-1	Parameter setting	Is there any fault in the consistency with the parameter?	Check if any remote I/O station is installed to the corresponding station number.	Combine the parameter and the installed model.
Unable to read/write cyclic data at the low order area.	E3-1	Parameter setting	Is there any fault in the consistency with the parameter?	Check if any device, which number of occupied stations is small, is installed to the corresponding station number.	Combine the number of occupied stations of the parameter and installed model.
Unable to RY-output.	E4-1	Refresh instruction	Is the refresh instruction (SB0003) executed?	Check if the refresh instruction (SB0003) is turned on.	Turn on the refresh instruction (SB0003).

## 15.2.3 When transient data are faulty

### (1) Problems on abnormal transient data of an intelligent device station (local station)

Description of problem	Check item		Check contents	Check procedure	Corrective action
Transient error	F1-1	Refresh data area	Is there any fault in the transient transmission (dedicated instruction)?	Check if a correct address is accessed.	Access the corresponding station address.
	F1-2	Parameter setting	Is there any fault in the consistency of the parameter?	Check if the remote I/O station or remote device station is installed.	Combine the parameter and the installed model.
	F1-3	Response status	Error code B404 <sub>H</sub> (response time up)	Check if there is no response from the request destination station within the monitoring time.	Make the setting value of monitoring time longer. However, if an error occurs, check the modules and cables at the request destination.
			Is there any fault in the transient transmission (dedicated instruction)?	Check the error code of the completion status when executing a dedicated instruction.	Take corrective actions according to the error codes of the completion status.
			Does any error occur at the master station or intelligent device station?	Check the error code of the programmable controller CPU. Check the error code of the master station. Check the operation status of the master station or target intelligent device station.	Take corrective actions according to the error code.
F1-4	Target station number	Is the target station number correct?	Check if transient transmission is not being executed for the same station number at the same time.	Correct the station number setting. If executing for the same station number, shift the execution timing.	

## 15.2.4 When operation of the master station is faulty

### (1) Problems on abnormal operation of the master station

Description of problem	Check item		Check contents	Check procedure	Corrective action
Unable to stop/restart the data link	G1-1	Data link stop	Is the data link stop (SB0002) turned on?	Check the program. Check the automatic refresh parameter.	Set the SB area properly. Turn on the data link stop (SB0002).
			Does any error occur?	Check the data link stop result (SW0045).	Take corrective actions according to the error code.
	G1-2	Data link restart	Is the data link restart (SB0000) turned on?	Check the program. Check the automatic refresh parameter.	Set the SB area properly. Turn on the data link restart (SB0000).
			Does any error occur?	Check the data link restart result (SW0041).	Take corrective actions according to the error code.
			Is the corresponding station disconnected?	Check the cable status visually or by the loop test of GX Works2. Check the parameter. (for local stations) Check the operation status of the programmable controller CPU at the corresponding station.	Review the cable and setting of the corresponding station and, startup properly.
Faulty stations cannot be detected.	G2-1	Is the station set to the error invalid station?	Is the station set to the error invalid station?	Check the error invalid station status (SW0078 to SW007B). Check the temporary error invalid station status (SW007C to SW007F).	Release the error invalid station setting. Release the temporary error invalid station setting.
		Are not station numbers overlapping?	Are not station numbers overlapping?	Check the station number setting.	Set the station number properly.
Faulty station occurs at certain transmission speeds.	G3-1	Can faulty stations be specified at the communication status of other stations (SW0080 to SW0083)? Can the communication be made normally at slow transmission speeds, such as 156 kbps?	Can faulty stations be specified at the communication status of other stations (SW0080 to SW0083)? Can the communication be made normally at slow transmission speeds, such as 156 kbps?	Check transmission speed of the faulty station.	Configure the transmission speed setting according to the master station.
				Check if the cables are wired correctly.	Wire the cable properly.
				Check if the cable shield is grounded.	Ground the shield.
				Check if the terminating resistor is connected to both ends in the CC-Link system.	Connect the terminating resistor to the both ends in the CC-Link system.
				Check if a station with built-in terminating resistor is connected other than at both ends in the CC-Link system.	
When multiple remote stations are powered off at 156 kbps, the "L RUN" LED goes off temporarily.	G4-1	Retry count setting	Retry count setting	Check the number of the retry count setting.	Increase the transmission speed. Reduce the retry count.

# 15.3 Error Codes

When a trouble such as data link failure has occurred, the cause can be identified by an error code.

## 15.3.1 How to check error codes

Error codes can be checked on GX Works2.

They can also be checked in link special registers (SW). (Refer to  Page 416, Appendix 3.2.)

### (1) Checking with GX Works2

Error codes that are corresponding to the errors occurred in the L series master/local module can be checked by following either procedure (a) or (b) described below.

#### (a) Checking on the "Module Detailed Information" window

Error code, error details, and corrective action are displayed.

In GX Works2, select [Diagnostics] ⇨ [System Monitor], and then click the [Detailed Information] button.

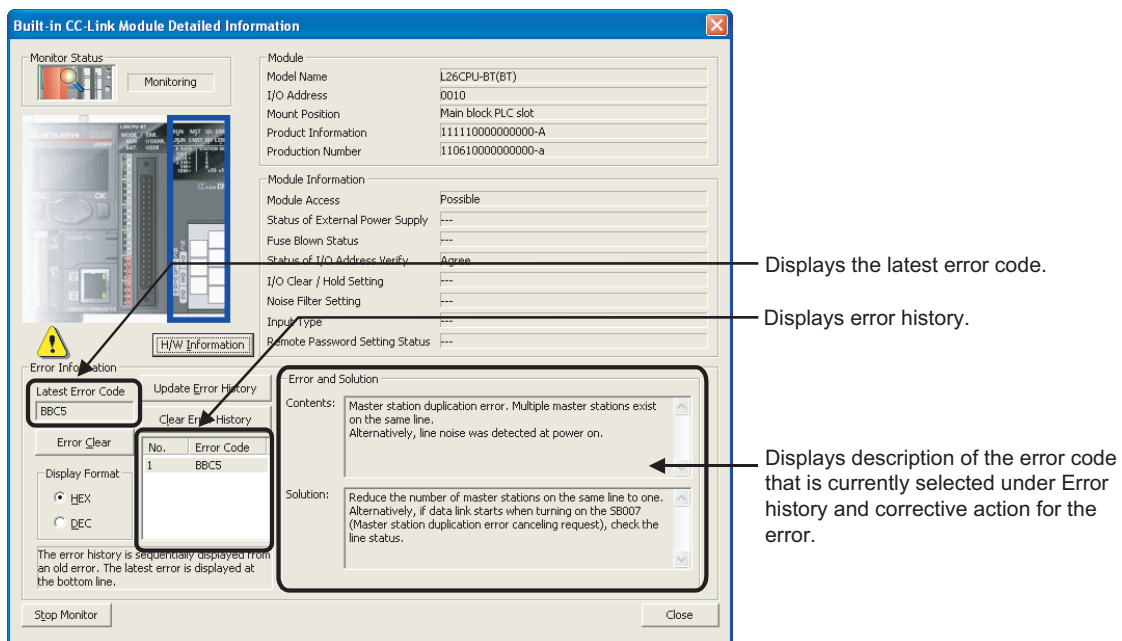

**(b) Checking on the "Error History" window**

On this window, errors including those occurred in other modules are displayed, and these data can be output in a CSV file.

Error code and date and time of error occurrence can be checked even after powering off and then on the programmable controller or resetting the programmable controller CPU.

In GX Works2, select [Diagnostics] ⇒ [System Monitor], and then click the [Error History Detail] button.

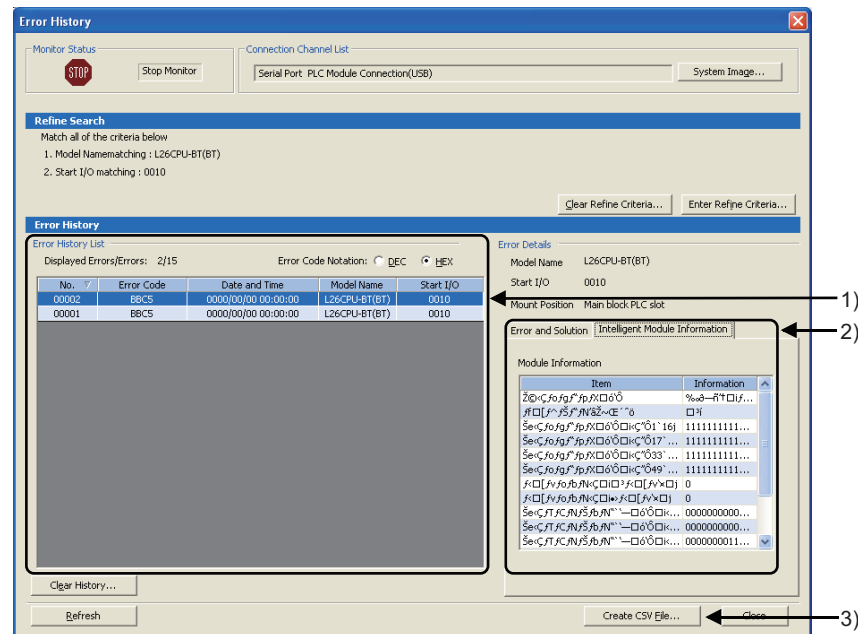
**1) Error History List**

The error log of the module is displayed.

For errors occurred during initial processing of the programmable controller CPU, the date and time will be 0000/00/00 00:00:00, therefore the displayed order under Error history list is not in the order in which the errors occurred. (Example: Station number setting error)

**2) Error and Solution, Intelligent Module Information**

- Error and Solution

The error description and corrective action for the error, which is currently selected under "Error History List", are displayed.

- Intelligent Module Information

The status of a QJ61BT11N when the error, which is currently selected under "Error History List", had occurred is displayed. \*1

\*1 When the error that simultaneously occurs with a network error is selected, the status right before the error occurrence may be displayed under Intelligent Module Information.

For the L series master/local module, the following will be displayed.

Item	Description
Action status	Operation status of the host station
Data link status	Data link status of the host station
Other station data link status (SW0080 to SW0083)	Data link status of each station 0: Normal 1: Data link error occurred
Line status (SW0090)	Line status
Master station information (SB0070)	Data link status
Standby master station information (SB0071)	Availability of the standby master station
Scan mode setting information (SB0072)	Settings of the scan mode
Operation specification when CPU is down status (SB0073)	Operation specification status when the CPU is down, which is set by parameters
Reserved station specified status (SB0074)	Reserved station specified status which is set by parameters
Error invalid station specified status (SB0075)	Error invalid station status which is set by parameters
Temporary error invalid station setting information (SB0076)	Whether the temporary error invalid station is set
Parameter receive status (SB0077)	Status of the parameter reception from the master station
Host station switch change detection (SB0078)	Changing status of the setting switches of the host station that is in data link
Master station return specification information (SB0079)	Whether the "Type" setting is set to "Master Station" or "Master Station (Duplex Function)" in Network parameter
Host master/standby master operation status (SB007B)	Whether the host station is operating as the master or standby master
Slave station refresh/compulsory clear setting status in case of programmable controller CPU STOP (SB007C)	Slave station refresh/compulsory clear setting status in case of programmable controller CPU stop which is set by parameters
Dedicated instruction	Dedicated instruction on which an error has occurred
Target station number	Station number of the transient transmission target station When it is not transient transmission error, "No Information" is displayed.

## 3) [Create CSV File] button

Click this button to output the module error history in a CSV file.

### Point

- If errors have frequently occurred in the L series master/local module, "\*\*HST.LOSS\*\*" may be displayed instead of an error code in the Error Code column.

No. ▾	Error Code	Date and Time	Model Name	Start I/O
00002	*HST.LOSS*	2009/12/23 13:54:17	L26CPU-BT	0000
00001	05DC	2009/12/23 13:53:38	L26CPU-BT	----

If too many "\*\*HST.LOSS\*\*" are displayed, increase the number of errors to be collected per scan in the "PLC RAS" tab of the "L Parameter Setting" dialog box.

For setting, refer to the following manual.

 MELSEC-L CPU Module User's Manual (Function Explanation, Program Fundamentals)

- When the same errors consecutively occurred, only the error code for the first occurred is displayed on the "Error History" window.

## 15.3.2 Error code list

The following shows the error codes list.

When a standby master station is used, refer to the respective columns under "Detectability" in the table as explained below.

- When a module is used as a master station: "Master station" column
- When a module is used as a standby master station: "Local station" column

Error code (hexadecimal)	Error details	Cause of error occurrence (details)	Corrective action	Detectability	
				Master station	Local station
4000 to 4FFF	Error detected in a CPU module (Refer to the MELSEC-L CPU Module User's Manual (Hardware Design, Maintenance and Inspection).)				
7000 to 7FFF	Error detected in a module such as a serial communication module (Refer to the Serial Communication Module User's Manual and other relevant manuals.)				
B002	System error	—	Please consult your local Mitsubishi representative.	○	×
B101 to B102					○
B103 to B106					×
B109					
B10A	Data link error detected in target stations	A data link error has occurred in the target stations during a message transmission.	Check the operation of the target stations.	○	×
B10C	Message transmission function unsupported	The message transmission function was executed for the slave station that does not support the function.	Check the station No. of the target station. Or, check if the target station supports the message transmission function.	○	×
B110	Transient data can not be received.	A line error has occurred.	Check the line.	○	○
B111	Transient data receiving order error	A line error has occurred.	Check the line.	○	○
B112	Transient data length error	A line error has occurred.	Check the line.	○	○
B113	Transient data ID error	A line error has occurred or an instantaneous power failure has occurred at the send station.	Check the line, or check the supply power and power supply module of the send station.	○	○
B115	Link error	A line error has occurred.	Check the line.	○	○
B116	Packet error	A line error has occurred.	Check the line.	○	○
B120	Forced termination of the remote device station initialize procedure registration function	In the remote device station initialize procedure registration function, the specification of the remote device station initialize procedure registration was turned off before all procedures were completed.	Do not turn the specification of the remote device station initialize procedure registration off until all procedures are completed.	○	×
B122	System error	—	Please consult your local Mitsubishi representative.	○	○
B123					×
B124	Error at a station on which the remote device station initialize procedure registration function was executed	The specification of the remote device station initialize procedure registration function was turned on at a station other than the master station.	Turn on the remote device station initialization procedure registration instruction on the master station (station No.0).	×	○
B125	Parameter not set error of the remote device station initialize procedure registration function	The specification of the remote device station initialize procedure registration function was turned on without setting the remote device station initialize procedure registration.	Turn on the specification of the remote device station initialize procedure registration after setting the remote device station initialize procedure registration.	○	×
		Bits corresponding to other than the head station number were turned ON in the Specification of remote device station to be initialized (SW0014 to SW0017) to instruct remote device station initialization procedure registration.	Turn ON only the bit corresponding to the head station number in the Specification of remote device station to be initialized (SW0014 to SW0017).		



Error code (hexadecimal)	Error details	Cause of error occurrence (details)	Corrective action	Detectability				
				Master station	Local station			
B201	Corresponding station error during sending	A data link error occurred at the corresponding station during transient transmission.	Check the communication status of other stations, whether or not a temporary error invalid station is specified, or if the corresponding station is stopped.	○	○			
B202 to B203	System error	—	Please consult your local Mitsubishi representative.	○	○			
B204	Transient request overload error	Too many transient requests were sent to the corresponding station.	Wait for a while and send the request again.	○	○			
B205	Transient target station error	A transient request was issued to other than the intelligent device station.	Check the target station.	○	○			
B301	Processing request error during link stop	Loop test request was issued while the link was stopped.	Perform a loop test while the link is being established	○	○			
B302	Specified station number setting error	The specified station number exceeded the highest communication station number during temporary error invalid request/temporary error invalid cancel request.	Specify a station number that is no greater than the highest communication station number.	○	×			
B303	Specified station number not set error	The station number was not specified during temporary error invalid request/temporary error invalid cancel request.	Set a specified station number. (SW0003, SW0004 to SW0007)	○	×			
B304	Loop test error station detected	An error was detected in a remote station, intelligent device station or standby master station when a loop test was performed.	Check that the remote station, intelligent device station or standby master station is operational and that the cable is not disconnected.	○	×			
B305	System error	—	Please consult your local Mitsubishi representative.	○	×			
B306	Specified station number setting error	A station number other than the head station number was specified during temporary error invalid request/temporary error invalid cancel request.	Specify a head station when temporary error invalid request/temporary error invalid cancel request is requested.	○	×			
B307	All stations data link error	All stations were in data link error status when one of the following requests was made: • Data link restart (SB0000) • Data link stop (SB0002)	Request again after the data link becomes normal.	○	○			
B308	Station number setting error (installation status)	The station number of the slave station is not within 1 to 64.	Set the station number of the slave station within the range between "1 and 64".	○	×			
B309	Station number overlap error	The station number of the connected module was duplicated (including number of occupied stations). However, this excludes the duplicate head station number.	Check the module station number.	○	×			
B30A	Loading/parameter consistency error	The station types of the module are different from parameter settings.	Set the correct parameters.	○	×			
		Example) <table border="1" style="margin-left: 20px;"> <tr> <td>Connected module</td> <td>Parameter setting</td> </tr> <tr> <td>Remote device</td> <td>Remote I/O</td> </tr> <tr> <td>Intelligent device</td> <td>Remote I/O</td> </tr> <tr> <td></td> <td>Remote device</td> </tr> </table>				Connected module	Parameter setting	Remote device
Connected module	Parameter setting							
Remote device	Remote I/O							
Intelligent device	Remote I/O							
	Remote device							
		The mode is inconsistent between the master station and a local or standby master station. • The modes of the master station and standby master station are different.	After correcting the parameters of the master station, the local station, or standby master station, reset the CPU module.					

Error code (hexadecimal)	Error details	Cause of error occurrence (details)	Corrective action	Detectability	
				Master station	Local station
B30B	Loading/parameter consistency error	The contents of the installation status and network parameters do not match.	Set the contents of the installation status and network parameters to match.	○	×
B30C	Standby master station specification error	Master station switching was instructed to a station other than the standby master station.	Specify the station number that corresponds to the standby master station.	○	○
B30D	Initial status	Temporary error invalid station specification, loop test request, or data link stop/restart request, etc. was issued before starting the link.	Issue the request after the data link is started.	○	○
B30E	Unsupported service by module	The function that is started with SB/SW and that only the master station supports was executed in a local station.	Execute the corresponding function from the master station.	×	○
B30F	Temporary error invalid station specification error	A temporary error invalid station was specified while the data link is being performed upon automatic CC-Link startup.	Specify a temporary error invalid station while the data link is performed with parameters set using a programming tool or the dedicated instruction.	○	×
B310	Data link restart error	Data link restart (SB0000) was executed for the station that was performing a data link.	Execute Data link restart (SB0000) for the station that has stopped a data link with Data link stop (SB0002).	○	○
B311	Data link stop error	Data link stop (SB0002) was executed for the station that had stopped a data link.	Execute Data link stop (SB0002) for the station that is performing a data link.	○	○
B312	Standby master station absence error	Forced master switching (SB000C) was executed in the system where no standby master station exists or in the system where the standby master station is faulty.	After starting the data link in the standby master station, execute Forced master switching (SB000C).	○	×
B313	All station fault error	Forced master switching (SB000C) was executed in the system where all stations are faulty.	After starting the data link in the standby master station, execute Forced master switching (SB000C).	○	×
B314	Switching target error	Forced master switching (SB000C) was executed to any station other than the master station.	Execute Forced master switching (SB000C) to the master station.	×	○
B315	Forced master station switching error	Forced master switching (SB000C) was instructed again while the master station was being switched to the standby master station.	Check ON/OFF of Forced master switching (SB000C).	○	×
B316	System error	—	Please consult your local Mitsubishi representative.	○	×
B317	Network startup setting mode error	The G(P).RLPASET instruction was executed to a module whose parameters have been set with a programming tool. The parameter setting was changed without powering off and on the programmable controller system or resetting the CPU module.	Clear the settings of the network parameters using a programming tool and set the network parameters of the target module using the G(P).RLPASET instruction	○	×
B31A	Data linking	Data link has already been started when the master station duplication error cancelling is instructed.	Do not instruct the master station duplication error cancelling during data linking.	○	×
B31B	Transmission speed test execution error	The transmission speed test was executed during data link.	Stop Data link and then execute the transmission speed test.	○	×
B31C to B31D	System error	—	Please consult your local Mitsubishi representative.	○	○
B31E	Status logging start error	Logging started while the log was being cleared.	Execute logging after clearing the logs.	○	○
B31F	Status logging clear error	Log was cleared while logging.	Stop logging and then clear the logs.	○	○
B320	Status logging mode invalid	The logging or log clear was executed In the remote I/O net mode.	Set the module to the remote net mode, then start the logging or log clear.	○	○

Error code (hexadecimal)	Error details	Cause of error occurrence (details)	Corrective action	Detectability	
				Master station	Local station
B321	System error	—	Please consult your local Mitsubishi representative.	○	○
B322	Status logging flash ROM clear invalid	During data link, the logs were cleared with "RAM + FlashROM" checked.	Stop the data link and then clear the logs.	○	○
B323	Status logging flash ROM clear incomplete	Clear of the logs was attempted with "RAM + FlashROM" checked, but logging started even though the clear was incomplete.	Clear the logs again with "RAM + FlashROM" checked.	○	○
B324	Status logging flash ROM storage error	The logs were attempted to be stored in the flash ROM even though the logs could not be stored in flash ROM.	After clearing the logs with "RAM + FlashROM" checked, start logging. Or, start the logging with "RAM" checked.	○	○
B325	Status logging flash ROM error	The total number of storing the logs in the flash ROM exceeded 100,000 times.	Start logging with "RAM" checked. For "RAM + FlashROM", replace the module.	○	○
B384	Station number setting error (parameter)	The station number (including the number of occupied stations) of the station information parameters was set to "other than 1 <sub>H</sub> to 40 <sub>H</sub> ".	Set within the range of "1 <sub>H</sub> to 40 <sub>H</sub> ".	○	×
B385	Total number of stations error (parameter)	The total number of occupied stations set with the station information parameter exceeded 64.	Set a parameter value of 64 or less.	○	×
B386	Number of occupied stations setting error (parameter)	The number of all occupied stations in the station information parameter was set to "0".	Set the occupied station number to a value between "1 and 4".	○	×
B387	Delay time setting error (parameter)	The delay time setting in the master station network parameters is out of the setting range.	Set 0 in the delay time setting.	○	×
B388	Station type setting error (parameter)	When the remote net ver.1 mode is used, a value set to the station type in the station information parameter is out of the setting range.	When the remote net ver.1 mode is used, set a value within the range from 0 to 2.	○	×
B38A	System error	—	Please consult your local Mitsubishi representative.	○	×
B38B	Remote device station setting error (parameter)	The number of remote device stations was set to "43 stations or more" with the station information parameter.	Set the remote device station to "42 stations or less" with the station information parameter.	○	×
B38C	Intelligent device station setting error (parameter)	The number of intelligent device stations (including local stations) was set to "27 stations or more" with the station information parameter.	Set the intelligent device station to "26 stations or less" with the station information parameter.	○	×
B38D	Invalid station specified error (parameter)	"Other than module head station number" or "station number not specified in the parameter" was set with the invalid station specification parameter. <Example of other than head station number> A bit other than that for station number 5 was ON for a module occupies 4 stations (station numbers 5 to 8).	Set the "Head station number of the module". Do not specify any of the stations not specified with the parameter.	○	×
B38E	Communication buffer assignment error (parameter)	The total size of the communication buffers in the station information parameter exceeded 4 K words.	Set the total size of the communication buffers to 4 K words or less.	○	×
B38F	Automatic update buffer assignment error (parameter)	The total size of the automatic update buffer in the station information parameter exceeded 4 K words.	Set the total size of the automatic update buffer to 4 K words or less.	○	×
B390	Standby master station specification error (parameter)	The standby master station parameter was set to a value other than "1 to 64".	Specify the standby master station to a value within the range from "1 to 64".	○	×
B391	Retry count setting error (parameter)	The retry count parameter was set to a value other than "1 to 7".	Set a value within the range from "1 to 7".	○	×

Error code (hexadecimal)	Error details	Cause of error occurrence (details)	Corrective action	Detectability	
				Master station	Local station
B392	Operation when CPU is down specified error (parameter)	The operation when the CPU is down specification parameter was set to a value other than "0 or 1".	Set "0 or 1".	○	×
B393	Scan mode specification error (parameter)	The scan mode parameter was set to a value other than "0 or 1".	Set "0 or 1".	○	○
B394	Number of automatic return stations setting error (parameter)	The number of automatic return stations parameter was set to a value other than "1 to 10".	Set a value within the range from "1 to 10".	○	×
B395	System error	—	Please consult your local Mitsubishi representative.	○	×
B396	Station number overlap error (parameter)	A duplicate station number was specified with the station information parameter.	Set so that station numbers are not duplicated.	○	×
B397	Station information setting error (parameter)	The station information parameter setting does not meet the following condition: $(16 \times A) + (54 \times B) + (88 \times C) \leq 2304$ A: Number of remote I/O stations B: Number of remote device stations C: Number of intelligent device stations (including local stations)	Set the parameter so that it meets the condition shown on left.	○	×
B398	Number of occupied stations setting error (parameter)	The number of occupied stations in the station information parameter was set to a value other than "1 to 4".	Set a value within the range from "1 to 4".	○	×
B399	Number of connected modules setting error (parameter)	The number of connected modules parameter was set to a value other than "1 to 64".	Set a value within the range from "1 to 64".	○	×
B39A	Standby master station specification error (loading status)	The station number of the standby master station differs from that set in the "Standby Master Station No." network parameter of the master station, or the station set in the "Standby Master Station No." network parameter of the master station is a local station.	Change the parameter setting of the master station, or change the station number setting of the local/standby master station, and then reset the CPU module of the local/standby master station.	×	○
B39B	Reserved station specification error	All stations were set as reserved stations.	Check the reserved station specification.	○	×
B39C	Standby master station setting error	Any other than Intelligent device station has been set to the station type for the "Standby Master Station No." specified in the master station network parameter. The mode setting is different between the master and standby master stations.	Specify the standby master station as an intelligent device station. Make the same setting to the master and standby master stations.	○	×
B39D	Reserved station 0 points setting error	Reserved station 0 points setting has been made in the remote net additional mode.	Change the mode to the remote net ver.2 mode.	○	×
		Reserved station 0 points setting has been made for the station that is not a reserved station.	Set the station of reserved 0 points setting as a reserved station.		
B39E	8/16-point remote I/O station setting error	Remote I/O station points setting is 8/16 points in the remote net additional mode.	Change the mode to the remote net ver.2 mode.	○	×
		8/16 points setting has been made for the station other than the remote I/O station.	8 points setting and 16 points setting have been made for the same remote I/O station.		
		Make 8/16 points setting for the same remote I/O station.	Make either 8 points setting or 16 points setting for the remote I/O station.		
B39F	Remote net additional mode station number invalid	In the remote net additional mode, the "maximum station number of ver.1 compatible slave stations" is greater than the "minimum station number of ver.2 compatible slave stations" in the network parameter setting.	In the remote net additional mode, make network parameter setting so that the "maximum station number of ver.1 compatible slave stations" is less than the "minimum station number of ver.2 compatible slave stations".	○	×

Error code (hexadecimal)	Error details	Cause of error occurrence (details)	Corrective action	Detectability	
				Master station	Local station
B3A0	Mode invalid (between master and local/standby master stations)	Model invalid has occurred between the master and local/standby master stations. • The mode differs between the master and standby master stations. • The local station is set to the remote net additional mode, and the master station is set to other than the remote net additional mode. • The local station is in the remote net ver.2 mode or remote net additional mode, and the master station is in the remote net ver.1 mode.	After correcting the mismatch of modes between the master and local/standby master stations, reset the CPU module.	×	○
B3A1	Standby master setting invalid	At the time of parameter setting with dedicated instruction, an invalid value has been set to switch 5 of the intelligent function module switch setting.	Set a correct value to switch 5 of the intelligent function module switch setting.	○	×
B3A2	Remote I/O net mode station type invalid	At the time of parameter setting with dedicated instruction, the station type of other than the remote I/O station has been set in the remote I/O net mode.	Set all station types to the remote I/O station.	○	×
B3A3	Assignment error	In the remote net Ver.2 mode or remote net additional mode, total points for remote stations set in the station information have exceeded the maximum of 8192.	Check the points for remote stations in the station information setting.	○	×
B3A4	Parameter mismatch	When the standby master station was operating as the master station with the master station duplex function, the network parameter setting of the faulty master station was changed.	Return the network parameter setting of the master station to the original value.	○	×
B3A5	Mode invalid (parameter)	The mode set in the control data of the G(P).RLPASET instruction differs from the mode set with the switch 3 of the intelligent function module switch setting.	Check the control data of the G(P).RLPASET instruction and the switch 3 setting of the intelligent function module switch setting.	○	×
B3F1 to B3F3	System error	—	Please consult your local Mitsubishi representative.	○	×
B401	Parameter change error	Parameter change was executed during transient request.	Change the parameter after all transient requests are completed or before any are requested.	○	○
B404	Response error	A response from the requested station was not returned within the watchdog time period.	Set a longer watchdog time. If an error persists, check the requested module and cables.	○	○
B405	Transient request error	A transient request was made to a remote I/O station or a remote device station. Or, too many transient requests were sent to the corresponding station.	Set the corresponding station to a local station or an intelligent device station. Or, wait for a while and send the request again (overload due to many transient requests).	○	○
B407	System error	—	Please consult your local Mitsubishi representative.	○	○
B409				×	
B410	Receive buffer size error	The receive buffer size of the dedicated instruction is less than the response data size.	Check the receive buffer size.	○	○
B411	Data length outside of range	The number of read/write points in the control data of the dedicated instruction is outside the setting range.	Change the number of read/write points to within the setting range.	○	○
B412	Station number outside of range	The station number in the control data of the dedicated instruction is outside the setting range.	Change the station number to within the setting range.	○	○
B413	Request error	Multiple dedicated instructions were executed for the same station.	Check the program.	○	○

Error code (hexadecimal)	Error details	Cause of error occurrence (details)	Corrective action	Detectability	
				Master station	Local station
B414	Interlock signal data outside of range	The setting of the interlock signal storage device of the G(P).RIRCV or G(P).RISEND instruction is outside the setting range.	Change the setting of the interlock signal storage device to within the setting range.	○	×
B415	Execution station type error	The dedicated instructions which can be executed on the master station only was executed on a station other than the master station.	Check if the host station type is a master station.	×	○
B416 to B417	System error	—	Please consult your local Mitsubishi representative.	○	×
B418	Receive data size error	With the message transmission function, an abnormal data was received.	Set the receivable data size to a value larger than the receive data size.	○	×
B419 to B41A	System error	—	Please consult your local Mitsubishi representative.	○	○
B601	Request type error	An unsupported request was received.	Check the contents of the request, as well as the target station number.	○	○
B602	Transient request overload error	There are too many transient requests to the corresponding station.	Wait a while and then send the requests (transient overload status).	○	○
B603	Transient request overload error	There are too many transient requests to the corresponding station.	Wait a while and then send the requests (transient overload status).	○	○
B604	Loop test in processing	Transient transmission was sent when a loop test was in progress.	Wait a while and then retransmit.	○	×
B605	Transient storage buffer could not be obtained	Transient storage buffer could not be obtained.	Wait a while and then retransmit.	○	○
B606	System error	—	Please consult your local Mitsubishi representative.	○	○
B607	Target station CPU error	There is an error in the target station's CPU.	Check the target CPU.	○	○
B608	Transient transmission target station mode setting error	Transient transmission was performed to the AJ61BT11 or A1SJ61BT11 in the I/O mode.	Set the target station to the intelligent mode.	○	○
B60C B700	System error	—	Please consult your local Mitsubishi representative.	○	○
B701 to B704	Transient transmission failure	Transient transmission failed.	<ul style="list-style-type: none"> <li>• Reduce the load placed on the transient transmission and perform the transmission again.</li> <li>• If the same error persists after taking the above action, please consult your local Mitsubishi representative.</li> </ul>	○	○
B705 to B706	System error	—	Please consult your local Mitsubishi representative.	○	○
B771	Transient request overload error	There are too many transient requests to the corresponding station.	Wait a while and then retransmit (transient overloaded status).	○	○
B772 to B773	System error	—	Please consult your local Mitsubishi representative.	○	○
B774	Transient request error	The target station was not an intelligent device station.	Check if the target station is an intelligent device station.	○	○
B775 to B777	Transient type error	Unsupported transient data was received.	Check the application of the request source.	○	○
B778	Response time out	A response was not received from the requested station.	Check the requested module and cables.	○	○
B779	System error	—	Please consult your local Mitsubishi representative.	○	○
B780	Module mode setting error	A transient transmission was executed even though the target station was set to the I/O mode.	Set to the remote net mode.	○	○
B781	System error	—	Please consult your local Mitsubishi representative.	○	○

Error code (hexadecimal)	Error details	Cause of error occurrence (details)	Corrective action	Detectability	
				Master station	Local station
B782	Station number specification error	The transmission destination and source stations were the same when other station connection was specified.	Check the transmission destination station number, or change to host connection.	○	○
B783	Transient storage buffer error	An error occurred in the transient storage buffer when a transient transmission of greater than 1 k was being performed.	Wait a while and then retransmit.	○	○
B801	Access code setting error	A non-existing access code/attribute was set.	Set a correct access code/attribute.	○	○
B802	Access code error	An access code that does not exist was used.	Use the correct access code.	○	○
B803	Data points error	The number of data points were out of range.	Set the number of data points to within 1 to 960 bytes.	○	○
B804	Attribute definition error Transient transmission unsupported station specification error	The attribute definition was invalid. Alternatively, transient transmission was performed even though the target station does not support transient transmission.	Review the attribute definition. Check the designation of the target station number, as well as the function version and software version of the target local station.	○	○
B805	Data points error	The number of data was out of range.	Set the range to within 1 to 100 when writing, and 1 to 160 when reading.	○	○
B807	Device No. error	The start device No. is out of range. Or, the address was not a multiple of 16 when the bit device was accessed.	Correct the start device No. Or, set the address to a multiple of 16 when accessing the bit device.	○	○
B80A	System error	—	Please consult your local Mitsubishi representative.	○	○
B80D	Setting range error	The specified combination (addresses and points) exceeded the valid processing range.	Set so that the number of processing points does not exceed the device range.	○	○
B80F to B812	System error	—	Please consult your local Mitsubishi representative.	○	○
B814	File register capacity setting error	The file register capacity was not specified.	Specify the file register capacity.	○	○
B815	Module mode setting error	A transient transmission was executed when the target station was set to the I/O mode.	Set to the intelli mode.	○	○
B817 B821 to B822	System error	—	Please consult your local Mitsubishi representative.	○	○
B823	Remote control mode error	The mode setting of the remote control was incorrect.	Check the mode specification.	○	○
B824 B826	System error	—	Please consult your local Mitsubishi representative.	○	○
B903	Transient request error	A transient request was issued to a station that has not secured a communication buffer area.	Secure a communication buffer area with a parameter.	○	○
B904	Communication buffer size setting error	The communication buffer size of the corresponding station was out of range when a dedicated instruction was executed.	Set the communication buffer size of the corresponding station within the range.	○	○
B905	Transient data length error	When the dedicated instruction is executed, the transient data length is greater than the communication buffer size of the corresponding station.	Make the communication buffer size of the corresponding station greater than the transient data length.	○	○
B981 to B982 B983 B984 B985 to B987 B9FF	System error	—	Please consult your local Mitsubishi representative.	○	×
BA01	Error (hardware test)	A hardware error has been detected.	Please consult your local Mitsubishi representative.	○	○

Error code (hexadecimal)	Error details	Cause of error occurrence (details)	Corrective action	Detectability	
				Master station	Local station
BA02	System error	—	Please consult your local Mitsubishi representative.	○	○
BA05					
BA06 to BA13	Error (hardware test)	A hardware error has been detected.	Please consult your local Mitsubishi representative.	○	○
BA14	Error (hardware test)	A hardware (communication circuit) error has been detected.	<ul style="list-style-type: none"> <li>• Check if the terminating resistor included with the L series master/local module is connected between the DA and DB terminals, and execute the hardware test again.</li> <li>• If the same error persists after taking the above action, please consult your local Mitsubishi representative.</li> </ul>	○	○
BA15	Error (hardware test)	A hardware error has been detected.	Please consult your local Mitsubishi representative.	○	○
BA16 to BA17	Error (hardware test)	A hardware (communication circuit) error has been detected.	<ul style="list-style-type: none"> <li>• Check if the terminating resistor included with the L series master/local module is connected between the DA and DB terminals, and execute the hardware test again.</li> <li>• If the same error persists after taking the above action, please consult your local Mitsubishi representative.</li> </ul>	○	○
BA19	Corresponding station error	The corresponding station that is being tested stopped communication during loop test 1.	Check the cable and the corresponding station.	○	×
BA1B	All stations error	All stations stopped communications during loop test 1.	Check the cables.	○	×
BA1E to BA21	Error (hardware test)	A hardware error has been detected.	Please consult your local Mitsubishi representative.	○	○
BB01	Concurrent execution error	<p>Any of the following were attempted to be executed to the same station. (Including the same requests)</p> <ul style="list-style-type: none"> <li>• Message transmission function</li> <li>• Remote device station initialization procedure registration function</li> <li>• G(P).RISEND or G(P).RIRCV instruction</li> <li>• Remote device station access from a peripheral.</li> </ul>	Execute a request after completion of another processing.	○	○
BBC1 to BBC3	System error	—	Please consult your local Mitsubishi representative.	○	○
BBC5	Master station duplication error	<p>Multiple master stations exist on the same line.</p> <p>Alternatively, line noise was detected at power on.</p>	Reduce the number of master stations on the same line to one. Alternatively, if data link starts when turning on the SB0007 (Master station duplication error canceling request), check the line status.	○	×
BBC7 to BBC8	System error	—	Please consult your local Mitsubishi representative.	○	○
BBCA	Standby master station duplication error	Multiple standby master stations exist on the same line.	Reduce the number of standby master stations on the same line to one. Alternatively, check the line status.	×	○
BBD1	System error	—	Please consult your local Mitsubishi representative.	○	○
BBD3					
BC01	All stations data link error	A data link error has occurred on all stations during a message transmission.	Issue the request after data link has started.	○	×



Error code (hexadecimal)	Error details	Cause of error occurrence (details)	Corrective action	Detectability	
				Master station	Local station
BC02	System error	—	Please consult your local Mitsubishi representative.	○	×
BC03	Message transmission target station failure	The target station specified for the message transmission function is in any of the following status. • No network parameter is set. • The specified station No. is not the head station number. • The station has been set as a reserved station. • A data link error (including All stations data link error) has occurred.	Check network parameters or target stations' operations.	○	×
BC04	Message transmission target station error	The message transmission was performed to a station other than remote device stations and intelligent device stations.	Check the target station.	○	×
BC05	Station No. out of range (Message transmission function)	The station No. specified for the message transmission function is out of the range between 1 and 64.	Check the specified station No.	○	×
BC06	Message transmission function executing station invalid	Execution of the message transmission function was attempted from a station other than the master station.	Execute the message transmission function on the master station.	×	○
BC07	Send data size out of range	The send data size was out of the range when message transmission was executed.	Change the send data size within the range.	○	×
BC08 to BC09	System error	—	Please consult your local Mitsubishi representative.	○	×
BC30				○	○
BC33 to BC34				○	○
BC35 to BC39				○	○
BC3A	×	○			
BC50	Message transmission handshake failure	With the message transmission function, abnormal data were received.	Check the program to see if any prohibited remote output (RY) has not been accessed. If the same error persists after checking the above, the master module or remote device station may be faulty. Please consult your local Mitsubishi representative.	○	×
BC51	Message transmission handshake failure	During execution of message transmission, a data link error has occurred on the corresponding station.	Check the operation of the target remote device station.	○	×
		During execution of message transmission, some parameters were changed.	Stop the data link, then change the parameters.		
		With the message transmission function, abnormal data were received.	Check the program to see if any prohibited remote output (RY) has not been accessed. If the same error persists after checking the above, the master module or remote device station may be faulty. Please consult your local Mitsubishi representative.		
BC52	Message transmission handshake timeout	With the message transmission function, a communication timeout has occurred.	Increase the value for Monitoring time setting (SW0009). If the error occurs again, check the request destination module and cables.	○	×
		Data link stop (SB0002) was executed during the message transmission.	Stop data link after completion of message transmission.		
		In the message transmission function, a stop error in the CPU module has been detected.	Set "Continue" in "PLC Down Select" to execute the message transmission while the stop error has occurred in the CPU module.		

Error code (hexadecimal)	Error details	Cause of error occurrence (details)	Corrective action	Detectability	
				Master station	Local station
BC53	Message transmission handshake timeout	In the message transmission function, a communication timeout has occurred.	Increase the value for Monitoring time setting (SW0009). If the error occurs again, check the request destination module and cables.	○	×
		Data link stop (SB0002) was executed during the message transmission.	Stop data link after completion of message transmission.		
		In the message transmission function, a stop error in the CPU module has been detected.	Set "Continue" in "PLC Down Select" to execute the message transmission while the stop error has occurred in the CPU module.		
BC54	Message transmission handshake failure	With the message transmission function, abnormal data were received.	Execute the message transmission function again. If the same error persists, the master module or remote device station may be faulty. Please consult your local Mitsubishi representative.	○	×
BC55					
BC57	Multiple requests error	Execution of multiple requests for message transmission or remote device station access from a peripheral was attempted to the same station.	Execute a request after completion of another processing.	○	×
BC58	Message transmission handshake failure	With the message transmission function, abnormal data were received.	Execute the message transmission function again. If the same error persists, the master module or remote device station may be faulty. Please consult your local Mitsubishi representative.	○	×
BC59					
BC5A	System error	—	Please consult your local Mitsubishi representative.	○	×
BC5B	Abnormal response received	With the message transmission function, an abnormal response was received.	Check the operation of the target remote device station.	○	×
BC5C to BC5F	Message transmission handshake failure	With the message transmission function, abnormal data were received.	Execute the message transmission function again. If the same error persists, the master module or remote device station may be faulty. Please consult your local Mitsubishi representative.	○	×
BC60	Invalid number of messages that were simultaneously transmitted	<ul style="list-style-type: none"> <li>The message transmission function was executed simultaneously for five or more remote device stations.</li> <li>The message transmission function was executed simultaneously for five or more intelligent device stations.</li> </ul>	Execute four requests or less at the same time.	○	×
BC70	No. of concurrent execution error (Remote device station access)	Too many remote device station accesses were requested from peripherals.	Execute four requests or less at the same time.	○	×
BC71	Unsupported function error (Remote device station access)	Execution of the remote device station access function was attempted from a station other than the master station.	Execute the function from the master station.	×	○
BC72	Target station error (Remote device station access)	<p>The target of remote device station access from the peripheral is any of the following.</p> <ul style="list-style-type: none"> <li>Does not exist among network parameters.</li> <li>Does not have the start station No.</li> <li>Has been set as a reserved station.</li> <li>Has a data link error (including errors on all stations).</li> </ul>	Check the parameters or operation of the target station.	○	×

Error code (hexadecimal)	Error details	Cause of error occurrence (details)	Corrective action	Detectability	
				Master station	Local station
BC73	Target station specification error (Remote device station access)	The target of the remote device station access from the peripheral is a remote I/O station.	Check the specified target station No. and station type.	○	×
BC74	Device No. error (Remote device station access)	Device No. for "RX", "RY", "RWw", or "RWr" is outside the valid range for the target station.	Check the parameters and valid device No. of the target station.	○	×
BC75	All-stations data link error (Remote device station access)	An all-stations data link error occurred during execution of the remote device station access from the peripheral.	Issue the request after starting data link.	○	×
BC76	Timeout (Remote device station access)	Timeout occurred during the remote device station access from the peripheral.	Set a longer timeout time in the application on the request source, or check the operation of the target slave station.	○	×
BC81	System error	—	Please consult your local Mitsubishi representative.	○	○
BC90	Message transmission result read target module station number error	The message transmission result read request was received from the station with an unacceptable target station number.	Correct the station number of the target station at the request source, and execute the function again.	○	○
BC91	Message transmission response receive timeout error	Timeout occurred in receiving message transmission response data.	Set a longer Monitoring time setting (SW0009) and execute the function again. If the same error occurs again, check the target station and cables.	○	×
BD83 to BD84	System error	—	Please consult your local Mitsubishi representative.	○	○
BD85	Hardware error detection	A hardware error was detected.	Please consult your local Mitsubishi representative.	○	○
BD86 to BD87	System error	—	Please consult your local Mitsubishi representative.	○	○
BF11 to BF1C					
BF20					
BF30 to BF37					
BF38	Execution result read error (Remote device station access)	An error is detected in the process of reading the execution result of the remote device station access from the peripheral.	<ul style="list-style-type: none"> <li>• Check the application of the request source.</li> <li>• Check for remote device station access from another peripheral.</li> </ul>	○	○
BF39	Request procedure error (Remote device station access)	An error in the request procedure is detected during the remote device station access from the peripheral.	<ul style="list-style-type: none"> <li>• Check the application of the request source.</li> <li>• Check for remote device station accesses from multiple peripherals.</li> <li>• Check if any value is written in the system area.</li> </ul>	○	○
BF40 to BF42	System error	—	Please consult your local Mitsubishi representative.	○	○
BF43	Message transmission target module station type error	The station type of a target station for the message transmission is not either a remote device station or intelligent device station.	Correct the station type of a target station, and execute the function again.	○	○
BF44	System error	—	Please consult your local Mitsubishi representative.	○	○
BFFA	Invalid number of messages that were simultaneously transmitted	The message transmission function was executed simultaneously for five or more intelligent device stations.	Execute four requests or less at the same time.	○	×
BFFB	Transient request overload error	There are too many transient requests from a programming tool or GOT.	Wait for a while and send the request again.	○	○
BFFE	CPU monitoring timer time out	The CPU monitoring timer timed out.	Check the operation of the target station.	○	○
C000 to CFFF	Error detected in an Ethernet interface module (Refer to the Ethernet Interface Module User's Manual and the MELSEC-L CPU Module User's Manual (Built-In Ethernet Function).)				

Error code (hexadecimal)	Error details	Cause of error occurrence (details)	Corrective action	Detectability	
				Master station	Local station
D000 to DFFF	Error detected in CC-Link IE Field Network (Refer to the CC-Link IE Field Network User's Manual.)				
E000 to EFFF	Error detected in CC-Link IE Controller Network (Refer to the CC-Link IE Controller Network Reference Manual.)				
F000 to FFFF	Error detected in a MELSECNET/H or MELSECNET/10 network system (Refer to the MELSECNET/H, MELSECNET/10 Network System Reference Manual.)				

# 15.4 CC-Link Diagnostics

Check the status of each module after all the modules have been connected using Ver.1.10 compatible CC-Link dedicated cable, and verify that data link can be performed normally.

## 15.4.1 Host monitoring/Other station monitoring







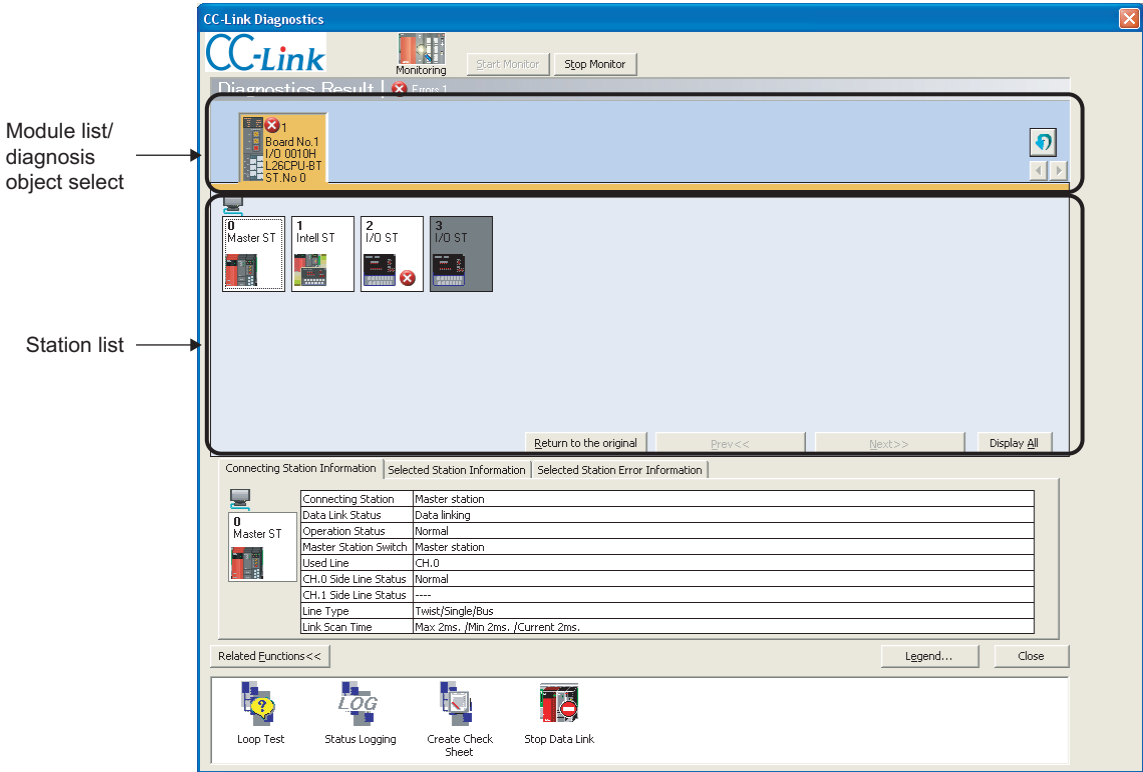



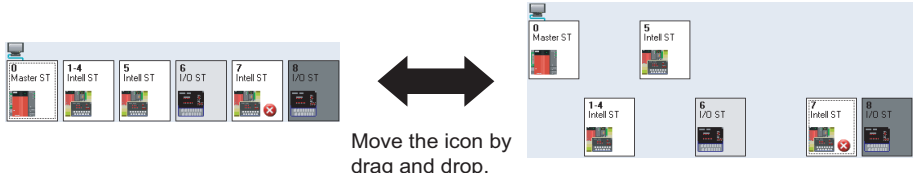

This function monitors the items such as the data link status of the host (the station to which peripheral devices are connected).

Select the [Diagnostics] ⇨ [CC-Link Diagnostics] on GX Works2.

CC-Link Diagnostics window is displayed. Perform the operation referring to the following explanations.



## (1) Description of CC-Link Diagnostics window

Item	Description																					
Diagnostics Result	Displays the number of all errors/warnings that have occurred on the L series master/local module(s).																					
Module list/diagnosis object select	<p>Displays the list of L series master/local modules and the number of errors and warnings). The diagnosis object can be changed by clicking a module.</p> <p> : Updates the list.</p> <p> : Switches the displayed modules by 8 modules.</p>																					
Station list	<p>Displays the list of stations that configure the CC-Link system. In the detailed display, the 24th station or later can be displayed by clicking [Next]. Display can be switched by clicking [Display All]/[Detail Display]. In all stations display, the information of all stations can be confirmed in one window. Icons can be placed freely by drag and drop. Clicking the [Return to the original] button places the icons back to their original position (in the order of station number).</p> <div data-bbox="448 831 1366 1003" style="text-align: center;">  <p>Move the icon by drag and drop.</p> </div>																					
Connected Station Information	Displays the data linking status, etc. of the connected station (host).																					
Selected Station Information	<p>Displays the number of the station, etc. of the (other) station selected in the station list.</p> <div data-bbox="639 1160 1177 1323" style="border: 1px solid gray; padding: 5px;"> <table border="1" style="width: 100%; border-collapse: collapse;"> <thead> <tr> <th style="width: 30%;">Connecting Station Information</th> <th style="width: 30%;">Selected Station Information</th> <th style="width: 30%;">Selected Station Error Information</th> </tr> </thead> <tbody> <tr> <td></td> <td>Station No. 0</td> <td></td> </tr> <tr> <td></td> <td>Number of Occupied Stations 1</td> <td></td> </tr> <tr> <td></td> <td>Station Type Master Station</td> <td></td> </tr> <tr> <td></td> <td>Company Z0+H'd&lt;@5'Z@%aZ0</td> <td></td> </tr> <tr> <td></td> <td>Connecting Module PLC</td> <td></td> </tr> <tr> <td></td> <td>Comment</td> <td></td> </tr> </tbody> </table> </div>	Connecting Station Information	Selected Station Information	Selected Station Error Information		Station No. 0			Number of Occupied Stations 1			Station Type Master Station			Company Z0+H'd<@5'Z@%aZ0			Connecting Module PLC			Comment	
Connecting Station Information	Selected Station Information	Selected Station Error Information																				
	Station No. 0																					
	Number of Occupied Stations 1																					
	Station Type Master Station																					
	Company Z0+H'd<@5'Z@%aZ0																					
	Connecting Module PLC																					
	Comment																					
Selected Station Error Information	<p>Displays the error information of the station selected in the station list.</p> <div data-bbox="635 1397 1182 1532" style="border: 1px solid gray; padding: 5px;"> <table border="1" style="width: 100%; border-collapse: collapse;"> <thead> <tr> <th style="width: 30%;">Connecting Station Information</th> <th style="width: 30%;">Selected Station Information</th> <th style="width: 30%;">Selected Station Error Information</th> </tr> </thead> <tbody> <tr> <td colspan="3">By double-clicking each error shown below, the details and corrective actions can be displayed.</td> </tr> <tr> <td></td> <td>Data link error</td> <td></td> </tr> </tbody> </table> </div>	Connecting Station Information	Selected Station Information	Selected Station Error Information	By double-clicking each error shown below, the details and corrective actions can be displayed.				Data link error													
Connecting Station Information	Selected Station Information	Selected Station Error Information																				
By double-clicking each error shown below, the details and corrective actions can be displayed.																						
	Data link error																					
[Related Functions]	<p>Switches to display or hide the related function icons. Refer to the following for details of the related functions.</p> <ul style="list-style-type: none"> <li>• "Loop Test" (Refer to  Page 378, Section 15.4.2.)</li> <li>• "Status Logging" (Refer to  Page 380, Section 15.4.3.)</li> <li>• "Create Check Sheet" (Refer to  Page 382, Section 15.4.4.)</li> <li>• "Start Data Link" / "Stop Data Link" (Refer to  Page 186, Section 8.3.8.)</li> </ul>																					

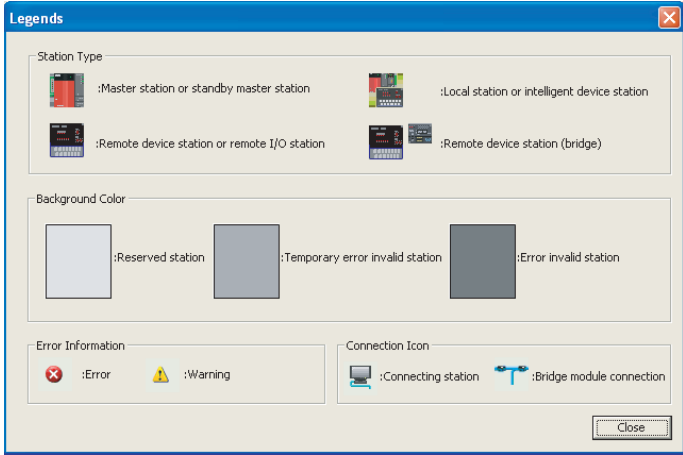
Item	Description
[Legend]	<p>Displays the explanation of the icons on the diagnostics window.</p>  <p>The screenshot shows a 'Legends' dialog box with the following sections:</p> <ul style="list-style-type: none"> <li><b>Station Type:</b> <ul style="list-style-type: none"> <li>Icon 1: Master station or standby master station</li> <li>Icon 2: Local station or intelligent device station</li> <li>Icon 3: Remote device station or remote I/O station</li> <li>Icon 4: Remote device station (bridge)</li> </ul> </li> <li><b>Background Color:</b> <ul style="list-style-type: none"> <li>Light gray square: Reserved station</li> <li>Medium gray square: Temporary error invalid station</li> <li>Dark gray square: Error invalid station</li> </ul> </li> <li><b>Error Information:</b> <ul style="list-style-type: none"> <li>Red X icon: Error</li> <li>Yellow triangle icon: Warning</li> </ul> </li> <li><b>Connection Icon:</b> <ul style="list-style-type: none"> <li>Computer icon: Connecting station</li> <li>Blue T-junction icon: Bridge module connection</li> </ul> </li> </ul> <p>A 'Close' button is located at the bottom right of the dialog box.</p>

**Point**

Updating of the number of errors/warnings in "Diagnostics Result"  
 Only the number of errors/warnings that have occurred in the network of the module selected in "Module list/diagnosis object select" is updated while monitoring.

For the number of errors/warnings of other modules, update the module list by clicking .

# 15.4.2 Loop test/Obtain transmission speed setting

## (1) Loop test

Checks the line operation of all stations or for the specified station.

### (a) Operation procedure

1. Connect all the modules with Ver.1.10 compatible CC-Link dedicated cables.
2. In GX Works2, select [Diagnostics] and then [CC-Link Diagnostics] and double-click the "Loop Test" icon.

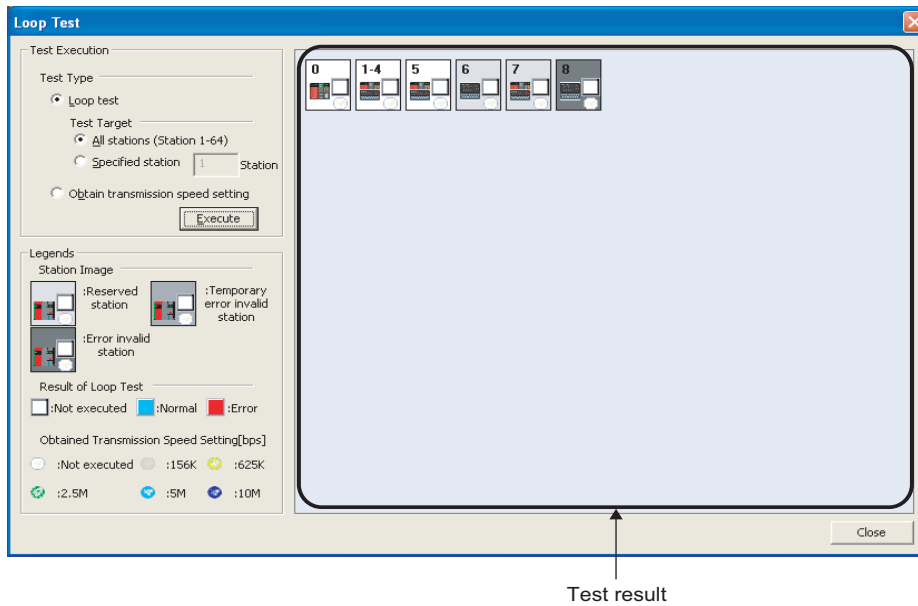

### 3. Set the test type to "Loop test".

Perform the loop test by selecting "All stations" or specifying a station number.  
 All stations: Select this when performing the test on all of the connected stations.  
 Specified station: Select this when performing the test on the specified station.  
 Specify the smallest number of the occupied stations.

**Ex** When a four-occupied station and a two-occupied station are connected

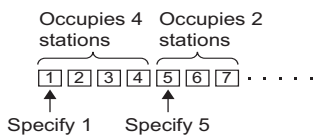

If 2, 3, 4 or 6 is specified, it will be detected as a faulty station.

### 4. Click the [Execute] button.

A loop test is performed, and the result is displayed in "Test result".



**(b) Precautions on the loop test**

- Do not write to buffer memory addresses 5E0<sub>H</sub> and 608<sub>H</sub>.
- Do not concurrently perform loop tests by programs and other peripherals. If this happens, the loop test may not operate normally.

**(2) Obtain transmission speed setting**

Checks the transmission speed settings of all stations.

**(a) Operation procedure**

1. Connect all the modules with Ver.1.10 compatible CC-Link dedicated cables.
2. Switch the programmable controller CPU switch to "STOP".
3. In GX Works2, select [Diagnostics] and then [CC-Link Diagnostics] and double-click the "Loop Test" icon.

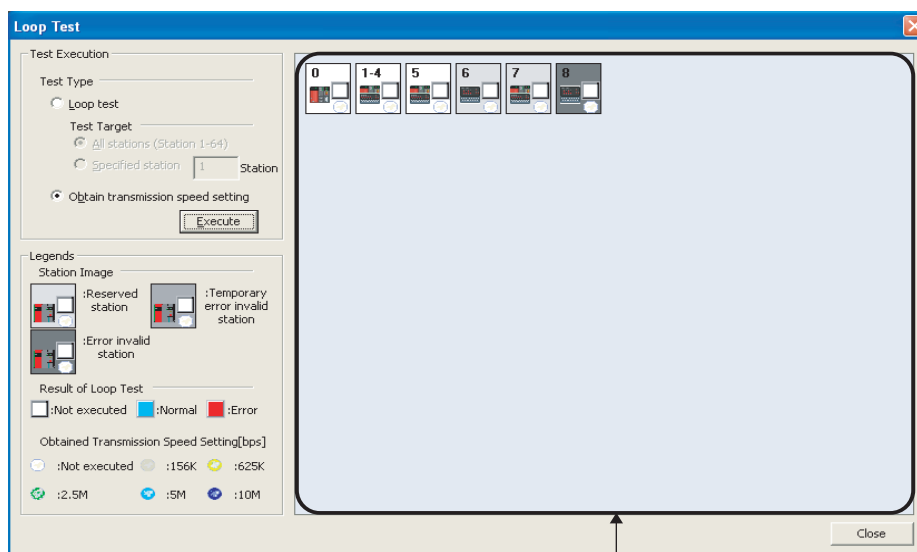

Test result

4. Select "Obtain transmission speed setting" for Test Type.

5. Click the [Execute] button.

The transmission speed settings are obtained, and the results are displayed in "Test result".

**(b) Precautions on "Obtain transmission speed setting"**

- Do not write to buffer memory addresses 5E0<sub>H</sub>, 5E4<sub>H</sub>, 5F8<sub>H</sub>, 641<sub>H</sub>, 645<sub>H</sub> and 783<sub>H</sub> to 787<sub>H</sub>.
- Do not concurrently obtain transmission speed settings by programs and other peripherals. If this happens, the "Obtain transmission speed setting" may not be operated normally.

Do not perform the "Obtain transmission speed setting" at the same time with the check sheet creation wizard.

## 15.4.3 Status logging

This function logs the data link status of all stations. When multiple stations, such as stations of a specific station number and higher, repeatedly fail and recover, the cause and location of the problem (e.g. poor cable contact or noise) can be identified easily.

If "RAM + Flash ROM" is selected, the first 45 logs after starting logging are stored to the flash ROM. The logs stored to the flash ROM can be checked after turning off and on the power or after resetting the programmable controller CPU.

### (1) Operating procedure

1. In GX Works2, select [Diagnostics] and then [CC-Link Diagnostics] and double-click the "Status Logging" icon.

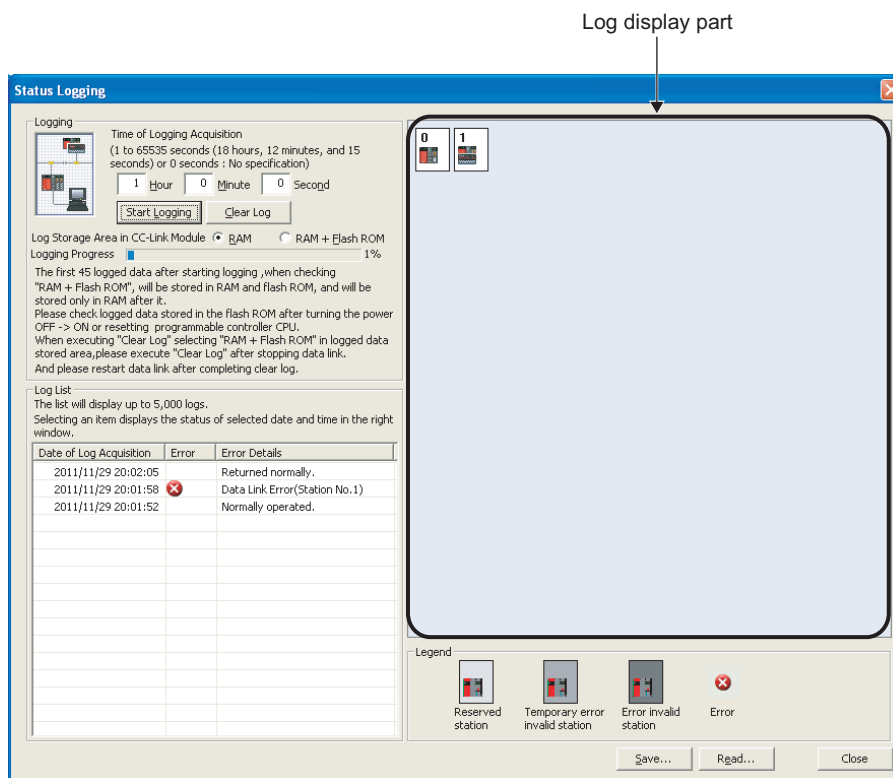

2. Select the log storage area.

Select either of "RAM" or "RAM + Flash ROM".

If GX Works2 cannot be connected continuously, select "RAM + Flash ROM". The logs (max. 45) stored in the flash ROM can be confirmed by connecting GX Works2 after the log collection.

If GX Works2 can be connected continuously, the maximum of 5000 logs can be collected for either "RAM" or "RAM + Flash ROM".

**3. Set the time for logging data acquisition.**

Enter the time during which logs are collected.

If "0" is set, log collection is continued until the [Stop Logging] button is clicked or the number of logs reaches 5000.

**4. Click the [Start Logging] button.**

Logs are collected during the specified logging collecting time.

However, the log collection is stopped when the [Stop Logging] button is clicked or the number of logs reaches 5000.

**5. If an item is selected in the log list, the status of the selected date/time is displayed in the "Log display part".****(a) Buttons in the dialog box**

[Clear Log]

Clears the logs in the module.

When "RAM + Flash ROM" is selected, the logs stored in flash ROM are also cleared. Do not power off the L series master/local module while the logs stored in flash ROM are being cleared.

[Save]/[Read]

Saves the Log List information in CSV format. Moreover, reads out the saved log file (CSV format) and displays the data in the Log List.

**(2) Precautions****(a) Logging does not start when:**

- Clearing the logs stored in the flash ROM is not completed.  
(Error code: B323<sub>H</sub>)
- With "RAM + Flash ROM" selected, 45 logs are already stored to flash ROM.  
(Error code: B324<sub>H</sub>)
- The total number of times the logs were stored in flash ROM exceeded 100,000.  
(Error code: B325<sub>H</sub>)

**(b) Log storage area and storable number of logs**

The following are the log storage areas:

- RAM area (inside the module): Up to 95 logs
- flash ROM area (inside the module): Up to 45 logs
- HDD for GX Works2 (personal computer): Up to 5000

When storing 96 logs or more (Max. 5000), keep GX Works2 connected even after starting logging.

If the number of logs in the RAM area exceeds 95 without connection to GX Works2, the oldest log is deleted, and the new log is stored.

## 15.4.4 Creating a check sheet

---

By following the wizard, check sheets can be created for troubleshooting with the open field network CC-Link troubleshooting guidance.

### (1) Operation procedure

1. In GX Works2, select [Diagnostics] and then [CC-Link Diagnostics] and double-click the "Create Check Sheet" icon.

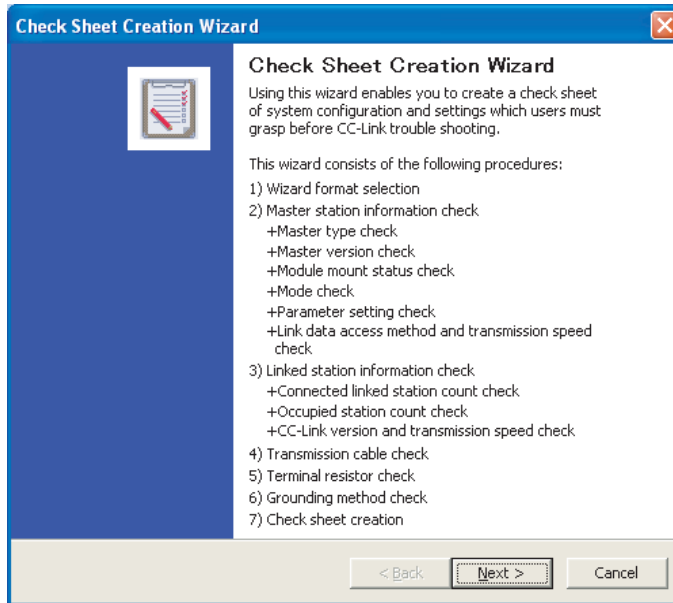

2. Set according to the window contents.  
The created check sheet is saved in Excel format.
3. Perform troubleshooting by using the open field network CC-Link troubleshooting guidance.

### Point

- Precautions when checking transmission speed  
Do not concurrently obtain transmission speed settings by programs and other peripherals. If this happens, the "Obtain transmission speed setting" may not be operated normally.
  - Check sheet  
When Microsoft® Excel 2000 or later is installed, the system configuration diagram is output.
-

(2) Example of check sheet

The following is an example of the check sheet when Microsoft® Excel 2000 or later is installed.

Confirmation Item	Contents		
1 Master Station	[1]Master Type	Programmable Controller PLC L26CPU-BT Master Module L26CPU-BT	
	[2]Master Version	Programmable Controller PLC 111110000000000A	
		Master Module 111110000000000A	
	[3]Module Mount Status	I/O Address: 0010H	
	[4]Other Network Module	Other Network Module: None	
	[5]Mode	Mode Setting: <input type="checkbox"/> Remote Net Mode( <input type="checkbox"/> Ver.1 / <input type="checkbox"/> Additional / <input type="checkbox"/> Ver.2) / <input type="checkbox"/> Remote I/O Net Mode	
		Scan Mode: <input type="checkbox"/> Synchronous/ <input type="checkbox"/> Asynchronous Mode	
		Module Mode: <input type="checkbox"/> I/O mode / <input type="checkbox"/> intelligent mode (SW8:A Series Only)	
	[6]Parameter	Checking the parameter matching status between the specification and PLC	
		Parameter	Setting
Number of PLCs		4Count	
Standby Master Station Setting		None	
PLC Down Drive Specification		<input type="checkbox"/> Stop/ <input type="checkbox"/> Continue	
Reserved Station		Station No.3	
Error Invalid Station		Station No.4	
[7]Parameter Setting	Station Information Written in the system configuration		
[8]Link Start Method	<input type="checkbox"/> GX WORKS2/ <input type="checkbox"/> Dedicated Instruction/ <input type="checkbox"/> FROM/TO Instruction		
[9]Link Data Access	<input type="checkbox"/> Startup by Buffer Memory:Y6 / <input type="checkbox"/> Startup by E2PROM:Y8 (Only QnA, A, FX Series)		
[10]Transmission Speed	<input type="checkbox"/> Auto Refresh/ <input type="checkbox"/> Dedicated Instruction/ <input type="checkbox"/> FROM/TO Instruction		
2 Linked Station *: The details have been described to the system configuration.	[11]Connected Count	4Count	
	[12]Station Type*	Remote I/O Station:0Count, Remote Device Station:0Count, Intelligent Device Station:4Count	
	[13]Number of Occupied Stations*	<input type="checkbox"/> Number of occupied stations of each station(Please check it when you confirm it.)	
	[14]CC-Link Version*	<input type="checkbox"/> Ver.1 / <input type="checkbox"/> Ver2(Expanded Cyclic Setting: <input type="checkbox"/> 1Times, <input type="checkbox"/> 2Times, <input type="checkbox"/> 4Times, <input type="checkbox"/> 8Times)	
	[15]Transmission Speed	<input type="checkbox"/> 10M/ <input type="checkbox"/> 5M / <input type="checkbox"/> 2.5M / <input type="checkbox"/> 625k / <input type="checkbox"/> 156kpbs	
3 Transmission Cable	[16]Cable Type	Cable Model Name:	
	[17]Transmission Distance	Total Extension Distance: m	
	[18]Inter-Station Distance	Distance between Shortest Station: m	
4 Terminal Resistor	[19]Resistance Value	<input type="checkbox"/> 110ohm / <input type="checkbox"/> 130ohm / <input type="checkbox"/> Not Exist	
	[20]Connected Terminal	<input type="checkbox"/> Connection between DA-DB of terminal resistor(Please check it when you confirm it.)	
5 Grounding	[21]FG Terminal	<input type="checkbox"/> Grounding of FG terminal of each station(Please check it when you confirm it.)	
		Describe the installation status to "6.System Configuration" when it is not set up in each station.	
6 System Configuration Station No., Station Type Number of Occupied Stations Length of Cable	[22]		

## 15.4.5 H/W information

This function displays the operating and setting states of the master module, local modules and standby master module.

### (1) Operation procedure (for the LJ61BT11)

1. Select [Diagnostics] ⇨ [System Monitor] in GX Works2.
2. Select the LJ61BT11.
3. Click the [H/W Information] button.

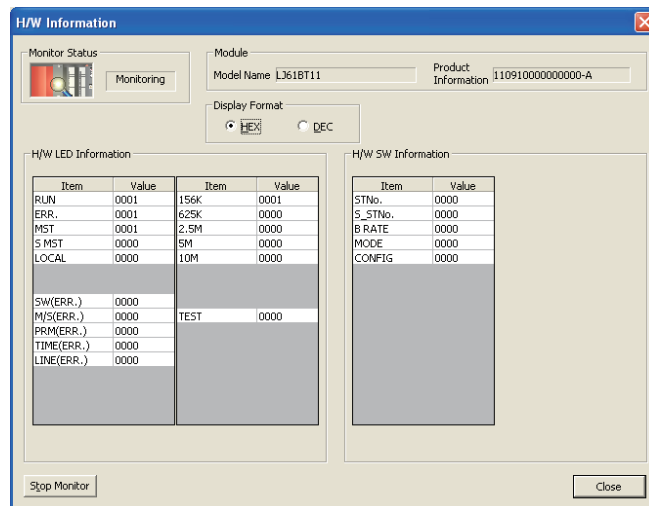

### (2) Product information

The function version and serial No. are displayed as follows.

11111000000000-A  
↑  
Function version A  
Serial No. (First 5 digits)

**(3) H/W LED Information**

The H/W LED Information area displays the following data link information.

Item	Value
RUN	1: Operating normally 0: Hardware error or watchdog timer error
ERR.	1: All stations are faulty Switching between 0 and 1: There is a faulty station
MST	1: Set to the master station
S MST	1: Set to the standby master station
LOCAL	1: Set to a local station
SW (ERR.)	1: Error in switch setting
M/S (ERR.)	1: A master station already exists on the same line
PRM (ERR.)	1: There is an error in parameter settings
TIME (ERR.)	1: The data link monitoring timer was activated
LINE (ERR.)	1: The cable is broken or the transmission path is affected by noise, etc.
156K	1: A transmission speed of 156 kbps is selected
625K	1: A transmission speed of 625 kbps is selected
2.5M	1: A transmission speed of 2.5 Mbps is selected
5M	1: A transmission speed of 5 Mbps is selected
10M	1: A transmission speed of 10 Mbps is selected
TEST	1: An offline test is being executed

**(4) H/W SW Information**

The H/W SW Information area displays the following information.

Item	Value
STNo.	Station number of the module when the power supply is turned on
S MSTNo.	Station number of the standby master station set by parameter (0: No standby master station specification)
B RATE	Setting of transmission speed
MODE	Mode setting status
CONFIG	Module operation status

# Memo

---



# APPENDICES

## Appendix 1 Details of the I/O Signals

The following explains the on/off timings and conditions of the I/O signals shown in "I/O Signal List" (refer to  Page 45, Section 3.5):

### (1) Module error: Xn0

This signal indicates whether the module is normal or faulty.

OFF: Module normal

ON: Module error

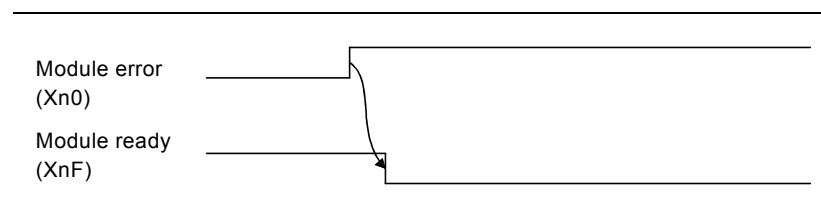

### (2) Host data link status: Xn1

This signal indicates the data link status of the host station.

SB006E also represents the same meaning. For programming, use either Xn1 or SB006E only.

Note that the ON/OFF condition for Xn1 is opposite to that for SB006E. When Xn1 is used, the condition is as follows:

OFF: Data link is stopped

ON: Data linking in progress

### (3) Other station data link status: Xn3

This signal indicates the data link status of other stations (slave stations).

The SB0080 signal has the same contents. For programming, use either Xn3 or SB0080 only.

OFF: All stations normal

ON: There is a faulty station (the faulty station status is stored in SW0080 to SW0083)

#### **Point**

The other station data link status (Xn3) takes up to 6 seconds to turn on after a slave station connected to the master/local station becomes faulty.

The time to turn ON differs according to the system configuration, faulty status or other conditions.

#### (4) Module ready: XnF

This signal indicates whether the module is ready to operate.

(a) When the module reaches ready-to-operate status, this signal turns ON automatically.

(b) This signal turns OFF when either of the following conditions occurs:

- When an error is detected in the switch setting status for the module
- When the module error signal (Xn0) turns ON

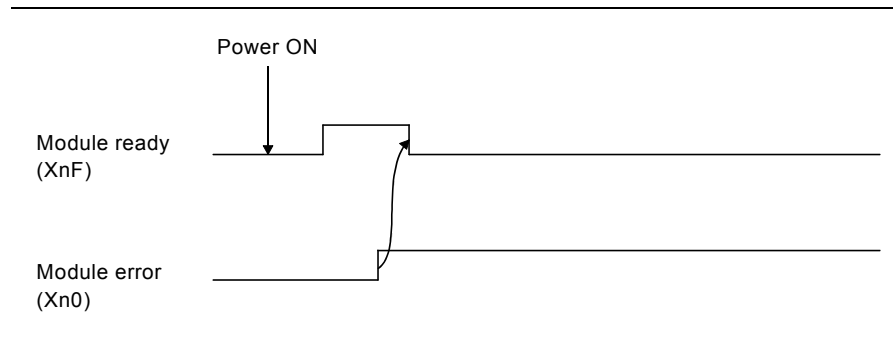

## Appendix 2 Buffer Memory Details

The following explains the details of items shown in "Buffer Memory List" (refer to  Page 47, Section 3.6).

### (1) Parameter information area

Stores the parameter settings.

Do not perform write to the parameter information area. Doing so may cause an error.

The following table lists the parameter information areas.

Address		Item	Description
Hex.	Dec.		
0 <sub>H</sub>	0	(Use prohibited)	—
1 <sub>H</sub>	1	Number of connected modules	Stores the total number of the slave stations that are connected to the master station (including reserved stations). Default value: 64 (modules) Storage area: 1 to 64 (modules)
2 <sub>H</sub>	2	Number of retries	Stores the number of retries when a communication error occurs. Default value: 3 (times) Storage area: 1 to 7 (times)
3 <sub>H</sub>	3	Number of automatic return modules	Stores the total number of the slave stations that can be returned to system operation by a single link scan. Default value: 1 (module) Storage area: 1 to 10 (modules)
4 <sub>H</sub>	4	Standby master station specification	Stores the station number of the standby master station. Default value: 0 (no standby master station specified) Storage area: 0 to 64 (0: No standby master station specified)
5 <sub>H</sub>	5	(Use prohibited)	—
6 <sub>H</sub>	6	Operation specification when CPU is down	Stores the data link status when a master station programmable controller CPU error occurs. Default value: 0 (Stop) Storage area: 0 (Stop), 1 (Continue)
7 <sub>H</sub>	7	Scan mode specification	Stores either the synchronous or asynchronous mode for sequence scan. Default value: 0 (Asynchronous) Storage area: 0 (Asynchronous), 1 (Synchronous)
8 <sub>H</sub>	8	Delay time setting	Set 0 for the delay time.
10 <sub>H</sub> to 13 <sub>H</sub>	16 to 19	Reserved station specification	Stores the reserved station. Default value: 0 (Not specified) Storage area: Bit corresponding to the station number turns on.
14 <sub>H</sub> to 17 <sub>H</sub>	20 to 23	Error invalid station specification	Stores the error invalid station. Default value: 0 (Not specified) Storage area: Bit corresponding to the station number turns on.
18 <sub>H</sub> to 1F <sub>H</sub>	24 to 31	(Use prohibited)	—

Address		Item	Description												
Hex.	Dec.														
20 <sub>H</sub> (first module) : 5F <sub>H</sub> (64th module)	32 (first module) : 95 (64th module)	Station information	<p>Stores the setting status of the types of the connected slave stations. Default value: 0101<sub>H</sub> (Ver.1 compatible remote I/O station, Occupies 1 station, Station number 1) to 0140<sub>H</sub> (Ver.1 compatible remote I/O station, Occupies 1 station, Station number 64) Storage area: Refer to the following</p> <table border="1" style="margin-left: auto; margin-right: auto;"> <tr> <td style="text-align: center;">b15 to b12</td> <td style="text-align: center;">b11 to b8</td> <td style="text-align: center;">b7 to b0</td> </tr> <tr> <td style="text-align: center;">Station type</td> <td style="text-align: center;">Number of occupied stations</td> <td style="text-align: center;">Station number</td> </tr> </table> <p style="margin-left: 100px;">         1<sub>H</sub>: Occupies 1 station          2<sub>H</sub>: Occupies 2 stations          3<sub>H</sub>: Occupies 3 stations          4<sub>H</sub>: Occupies 4 stations          (01<sub>H</sub> to 40<sub>H</sub>)       </p> <p>         0<sub>H</sub>: Ver. 1 compatible remote I/O station          1<sub>H</sub>: Ver. 1 compatible remote device station          2<sub>H</sub>: Ver. 1 compatible intelligent device station          5<sub>H</sub>: Ver. 2 compatible single remote device station          6<sub>H</sub>: Ver. 2 compatible single intelligent device station          8<sub>H</sub>: Ver. 2 compatible double remote device station          9<sub>H</sub>: Ver. 2 compatible double intelligent device station          B<sub>H</sub>: Ver. 2 compatible quadruple remote device station          C<sub>H</sub>: Ver. 2 compatible quadruple intelligent device station          E<sub>H</sub>: Ver. 2 compatible octuple remote device station          F<sub>H</sub>: Ver. 2 compatible octuple intelligent device station       </p>	b15 to b12	b11 to b8	b7 to b0	Station type	Number of occupied stations	Station number						
b15 to b12	b11 to b8	b7 to b0													
Station type	Number of occupied stations	Station number													
60 <sub>H</sub> to 7F <sub>H</sub>	96 to 127	(Use prohibited)	—												
<table border="0" style="width: 100%;"> <tr> <td style="width: 50%; vertical-align: top;">           80<sub>H</sub>(Send buffer)            81<sub>H</sub>(Receive buffer)            82<sub>H</sub>(Automatic update buffer)         </td> <td style="width: 5%; text-align: center; vertical-align: middle;">} The first intelligent device</td> <td style="width: 45%; vertical-align: top;">           128(Send buffer)            129(Receive buffer)            130(Automatic update buffer)         </td> <td style="width: 5%; text-align: center; vertical-align: middle;">} The first intelligent device</td> </tr> <tr> <td colspan="4" style="text-align: center;">to</td> </tr> <tr> <td style="width: 50%; vertical-align: top;">           CB<sub>H</sub>(Send buffer)            CC<sub>H</sub>(Receive buffer)            CD<sub>H</sub>(Automatic update buffer)         </td> <td style="width: 5%; text-align: center; vertical-align: middle;">} The 26th intelligent device</td> <td style="width: 45%; vertical-align: top;">           203(Send buffer)            204(Receive buffer)            205(Automatic update buffer)         </td> <td style="width: 5%; text-align: center; vertical-align: middle;">} The 26th intelligent device</td> </tr> </table>	80 <sub>H</sub> (Send buffer) 81 <sub>H</sub> (Receive buffer) 82 <sub>H</sub> (Automatic update buffer)	} The first intelligent device	128(Send buffer) 129(Receive buffer) 130(Automatic update buffer)	} The first intelligent device	to				CB <sub>H</sub> (Send buffer) CC <sub>H</sub> (Receive buffer) CD <sub>H</sub> (Automatic update buffer)	} The 26th intelligent device	203(Send buffer) 204(Receive buffer) 205(Automatic update buffer)	} The 26th intelligent device		Allocation of communication buffer and automatic update buffer	<p>Stores the buffer memory assignment status at transient transmission to the local, intelligent device and standby master stations. Default value Send buffer size: 40<sub>H</sub> (64) (word) Receive buffer size: 40<sub>H</sub> (64) (word) Automatic update buffer size: 80<sub>H</sub> (128) (word) Storage area</p> <ul style="list-style-type: none"> <li>Communication buffer: 0<sub>H</sub> (0) (word) (no setting) or 40<sub>H</sub> (64) (word) to 1000<sub>H</sub> (4096) (word) Note that the total size of the communication buffer is within 1000<sub>H</sub> (4096) (word).</li> <li>Automatic update buffer: 0<sub>H</sub> (0) (word) (no setting) or 80<sub>H</sub> (128) (word) to 1000<sub>H</sub> (4096) (word) Note that the total size of the automatic update buffers is within 1000<sub>H</sub> (4096) (word).</li> </ul>
80 <sub>H</sub> (Send buffer) 81 <sub>H</sub> (Receive buffer) 82 <sub>H</sub> (Automatic update buffer)	} The first intelligent device	128(Send buffer) 129(Receive buffer) 130(Automatic update buffer)	} The first intelligent device												
to															
CB <sub>H</sub> (Send buffer) CC <sub>H</sub> (Receive buffer) CD <sub>H</sub> (Automatic update buffer)	} The 26th intelligent device	203(Send buffer) 204(Receive buffer) 205(Automatic update buffer)	} The 26th intelligent device												
CE <sub>H</sub> , CF <sub>H</sub>	206, 207	(Use prohibited)	—												
D0 <sub>H</sub> to D3 <sub>H</sub>	208 to 211	8-point remote I/O station setting	Stores the station numbers of the remote I/O stations set as 8 points in the remote I/O station points setting. *1,*2 Default value: 0 (no setting) Storage area: Bit corresponding to the station number turns on.												
D4 <sub>H</sub> to D7 <sub>H</sub>	212 to 215	16-point remote I/O station setting	Stores the station numbers of the remote I/O stations set as 16 points in the remote I/O station points setting. *1,*2 Default value: 0 (no setting) Storage area: Bit corresponding to the station number turns on.												
D8 <sub>H</sub> to DB <sub>H</sub>	216 to 219	0 points reserved station setting	Stores the station numbers of the reserved stations set to 0 points.*1 Default value: 0 (no setting) Storage area: Bit corresponding to the station number turns on.												

Address		Item	Description
Hex.	Dec.		
DC <sub>H</sub> to DF <sub>H</sub>	220 to 223	(Use prohibited)	—

\*1 Used in the remote net ver.2 mode or remote net additional mode.

\*2 When the setting is "8 Points + 8 Points (Reserved)", the station numbers are stored into both the 8-point remote I/O station setting and 16-point remote I/O station setting.

## (2) Remote input (RX) and remote output (RY)

Used when the remote net ver.1 mode, remote net additional mode or remote I/O network mode is selected.

### (a) Master station ← remote I/O station/remote device station/local station

- Master station
  - The input data from the remote I/O station, remote device station (RX) and local station (RY) is stored.
  - Two words are used per station.
- Local station
  - Data to be sent to the master station is stored in the remote output (RY) of the address corresponding to the host station number.
  - The input data from the remote I/O station, remote device station (RX) and other local station is stored.
  - Two words are used per station.

▮ ... The last two bits cannot be used for communication between the master station and the local station.  
(In the example below, RY9E and RY9F cannot be used.)

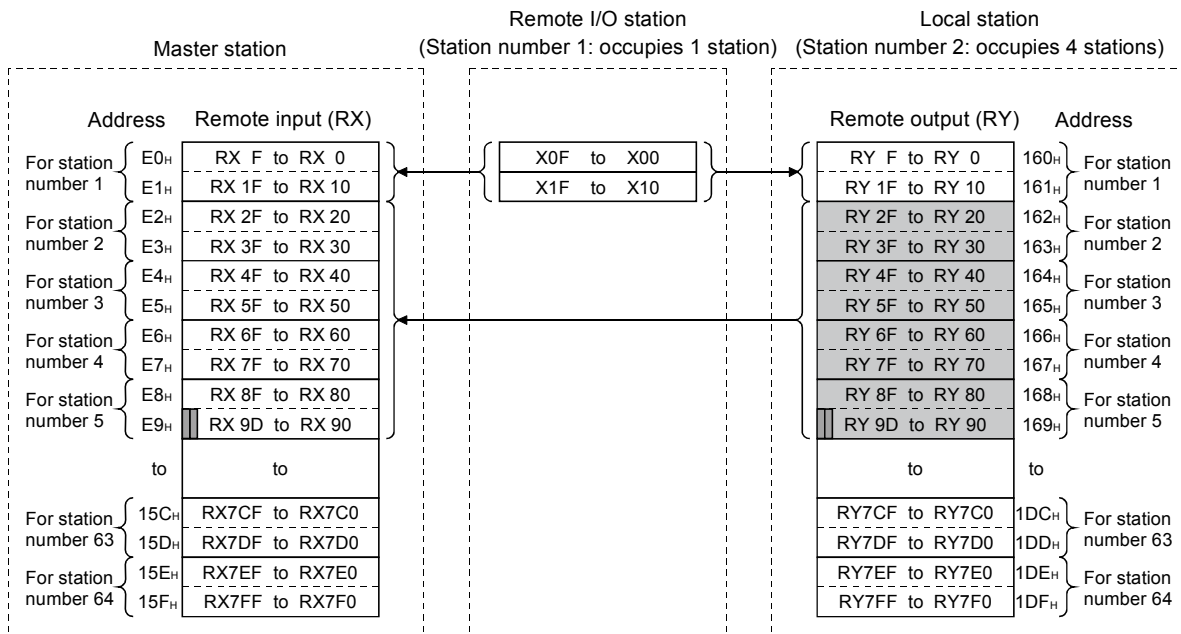

The following tables show the station numbers and corresponding buffer-memory addresses.

[Master station]

Table of station numbers and corresponding buffer memory addresses

Station number	Buffer memory address	Station number	Buffer memory address	Station number	Buffer memory address	Station number	Buffer memory address	Station number	Buffer memory address
1	E0 <sub>H</sub> to E1 <sub>H</sub>	14	FA <sub>H</sub> to FB <sub>H</sub>	27	114 <sub>H</sub> to 115 <sub>H</sub>	40	12E <sub>H</sub> to 12F <sub>H</sub>	53	148 <sub>H</sub> to 149 <sub>H</sub>
2	E2 <sub>H</sub> to E3 <sub>H</sub>	15	FC <sub>H</sub> to FD <sub>H</sub>	28	116 <sub>H</sub> to 117 <sub>H</sub>	41	130 <sub>H</sub> to 131 <sub>H</sub>	54	14A <sub>H</sub> to 14B <sub>H</sub>
3	E4 <sub>H</sub> to E5 <sub>H</sub>	16	FE <sub>H</sub> to FF <sub>H</sub>	29	118 <sub>H</sub> to 119 <sub>H</sub>	42	132 <sub>H</sub> to 133 <sub>H</sub>	55	14C <sub>H</sub> to 14D <sub>H</sub>
4	E6 <sub>H</sub> to E7 <sub>H</sub>	17	100 <sub>H</sub> to 101 <sub>H</sub>	30	11A <sub>H</sub> to 11B <sub>H</sub>	43	134 <sub>H</sub> to 135 <sub>H</sub>	56	14E <sub>H</sub> to 14F <sub>H</sub>
5	E8 <sub>H</sub> to E9 <sub>H</sub>	18	102 <sub>H</sub> to 103 <sub>H</sub>	31	11C <sub>H</sub> to 11D <sub>H</sub>	44	136 <sub>H</sub> to 137 <sub>H</sub>	57	150 <sub>H</sub> to 151 <sub>H</sub>
6	EA <sub>H</sub> to EB <sub>H</sub>	19	104 <sub>H</sub> to 105 <sub>H</sub>	32	11E <sub>H</sub> to 11F <sub>H</sub>	45	138 <sub>H</sub> to 139 <sub>H</sub>	58	152 <sub>H</sub> to 153 <sub>H</sub>
7	EC <sub>H</sub> to ED <sub>H</sub>	20	106 <sub>H</sub> to 107 <sub>H</sub>	33	120 <sub>H</sub> to 121 <sub>H</sub>	46	13A <sub>H</sub> to 13B <sub>H</sub>	59	154 <sub>H</sub> to 155 <sub>H</sub>
8	EE <sub>H</sub> to EF <sub>H</sub>	21	108 <sub>H</sub> to 109 <sub>H</sub>	34	122 <sub>H</sub> to 123 <sub>H</sub>	47	13C <sub>H</sub> to 13D <sub>H</sub>	60	156 <sub>H</sub> to 157 <sub>H</sub>
9	F0 <sub>H</sub> to F1 <sub>H</sub>	22	10A <sub>H</sub> to 10B <sub>H</sub>	35	124 <sub>H</sub> to 125 <sub>H</sub>	48	13E <sub>H</sub> to 13F <sub>H</sub>	61	158 <sub>H</sub> to 159 <sub>H</sub>
10	F2 <sub>H</sub> to F3 <sub>H</sub>	23	10C <sub>H</sub> to 10D <sub>H</sub>	36	126 <sub>H</sub> to 127 <sub>H</sub>	49	140 <sub>H</sub> to 141 <sub>H</sub>	62	15A <sub>H</sub> to 15B <sub>H</sub>
11	F4 <sub>H</sub> to F5 <sub>H</sub>	24	10E <sub>H</sub> to 10F <sub>H</sub>	37	128 <sub>H</sub> to 129 <sub>H</sub>	50	142 <sub>H</sub> to 143 <sub>H</sub>	63	15C <sub>H</sub> to 15D <sub>H</sub>
12	F6 <sub>H</sub> to F7 <sub>H</sub>	25	110 <sub>H</sub> to 111 <sub>H</sub>	38	12A <sub>H</sub> to 12B <sub>H</sub>	51	144 <sub>H</sub> to 145 <sub>H</sub>	64	15E <sub>H</sub> to 15F <sub>H</sub>
13	F8 <sub>H</sub> to F9 <sub>H</sub>	26	112 <sub>H</sub> to 113 <sub>H</sub>	39	12C <sub>H</sub> to 12D <sub>H</sub>	52	146 <sub>H</sub> to 147 <sub>H</sub>	—	—

[Local station]

Table of station numbers and corresponding buffer memory addresses

Station number	Buffer memory address	Station number	Buffer memory address	Station number	Buffer memory address	Station number	Buffer memory address	Station number	Buffer memory address
1	160 <sub>H</sub> to 161 <sub>H</sub>	14	17A <sub>H</sub> to 17B <sub>H</sub>	27	194 <sub>H</sub> to 195 <sub>H</sub>	40	1AE <sub>H</sub> to 1AF <sub>H</sub>	53	1C8 <sub>H</sub> to 1C9 <sub>H</sub>
2	162 <sub>H</sub> to 163 <sub>H</sub>	15	17C <sub>H</sub> to 17D <sub>H</sub>	28	196 <sub>H</sub> to 197 <sub>H</sub>	41	1B0 <sub>H</sub> to 1B1 <sub>H</sub>	54	1CA <sub>H</sub> to 1CB <sub>H</sub>
3	164 <sub>H</sub> to 165 <sub>H</sub>	16	17E <sub>H</sub> to 17F <sub>H</sub>	29	198 <sub>H</sub> to 199 <sub>H</sub>	42	1B2 <sub>H</sub> to 1B3 <sub>H</sub>	55	1CC <sub>H</sub> to 1CD <sub>H</sub>
4	166 <sub>H</sub> to 167 <sub>H</sub>	17	180 <sub>H</sub> to 181 <sub>H</sub>	30	19A <sub>H</sub> to 19B <sub>H</sub>	43	1B4 <sub>H</sub> to 1B5 <sub>H</sub>	56	1CE <sub>H</sub> to 1CF <sub>H</sub>
5	168 <sub>H</sub> to 169 <sub>H</sub>	18	182 <sub>H</sub> to 183 <sub>H</sub>	31	19C <sub>H</sub> to 19D <sub>H</sub>	44	1B6 <sub>H</sub> to 1B7 <sub>H</sub>	57	1D0 <sub>H</sub> to 1D1 <sub>H</sub>
6	16A <sub>H</sub> to 16B <sub>H</sub>	19	184 <sub>H</sub> to 185 <sub>H</sub>	32	19E <sub>H</sub> to 19F <sub>H</sub>	45	1B8 <sub>H</sub> to 1B9 <sub>H</sub>	58	1D2 <sub>H</sub> to 1D3 <sub>H</sub>
7	16C <sub>H</sub> to 16D <sub>H</sub>	20	186 <sub>H</sub> to 187 <sub>H</sub>	33	1A0 <sub>H</sub> to 1A1 <sub>H</sub>	46	1BA <sub>H</sub> to 1BB <sub>H</sub>	59	1D4 <sub>H</sub> to 1D5 <sub>H</sub>
8	16E <sub>H</sub> to 16F <sub>H</sub>	21	188 <sub>H</sub> to 189 <sub>H</sub>	34	1A2 <sub>H</sub> to 1A3 <sub>H</sub>	47	1BC <sub>H</sub> to 1BD <sub>H</sub>	60	1D6 <sub>H</sub> to 1D7 <sub>H</sub>
9	170 <sub>H</sub> to 171 <sub>H</sub>	22	18A <sub>H</sub> to 18B <sub>H</sub>	35	1A4 <sub>H</sub> to 1A5 <sub>H</sub>	48	1BE <sub>H</sub> to 1BF <sub>H</sub>	61	1D8 <sub>H</sub> to 1D9 <sub>H</sub>
10	172 <sub>H</sub> to 173 <sub>H</sub>	23	18C <sub>H</sub> to 18D <sub>H</sub>	36	1A6 <sub>H</sub> to 1A7 <sub>H</sub>	49	1C0 <sub>H</sub> to 1C1 <sub>H</sub>	62	1DA <sub>H</sub> to 1DB <sub>H</sub>
11	174 <sub>H</sub> to 175 <sub>H</sub>	24	18E <sub>H</sub> to 18F <sub>H</sub>	37	1A8 <sub>H</sub> to 1A9 <sub>H</sub>	50	1C2 <sub>H</sub> to 1C3 <sub>H</sub>	63	1DC <sub>H</sub> to 1DD <sub>H</sub>
12	176 <sub>H</sub> to 177 <sub>H</sub>	25	190 <sub>H</sub> to 191 <sub>H</sub>	38	1AA <sub>H</sub> to 1AB <sub>H</sub>	51	1C4 <sub>H</sub> to 1C5 <sub>H</sub>	64	1DE <sub>H</sub> to 1DF <sub>H</sub>
13	178 <sub>H</sub> to 179 <sub>H</sub>	26	192 <sub>H</sub> to 193 <sub>H</sub>	39	1AC <sub>H</sub> to 1AD <sub>H</sub>	52	1C6 <sub>H</sub> to 1C7 <sub>H</sub>	—	—

**(b) Master station → remote I/O station/remote device station/local station**

- Master station
  - The output data to the remote I/O station, remote device station (RY) and all local stations (RX) is stored.
  - Two words are used per station.
- Local station
  - The data received from the remote I/O station, remote device station (RY) and master station (RY) is stored.
  - Two words are used per station.

▮ ... The last two bits cannot be used for communication between the master station and the local station.  
(In the example below, RY9E and RY9F cannot be used.)

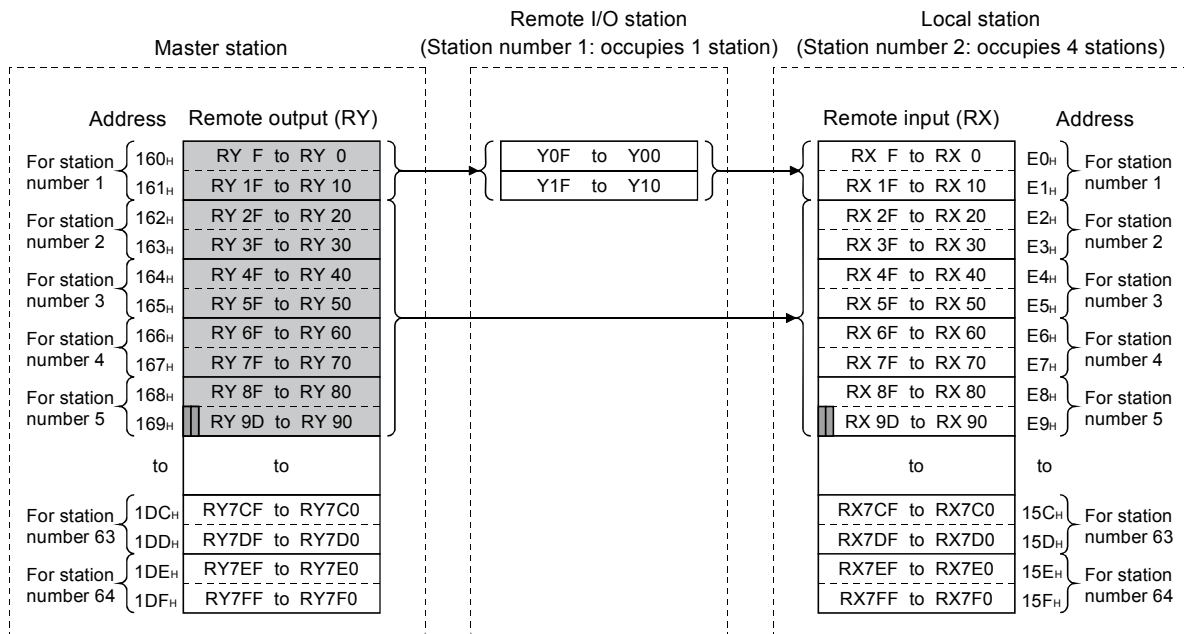



The following tables show the station numbers and corresponding buffer memory addresses.

[Master station]

Table of station numbers and corresponding buffer memory addresses

Station number	Buffer memory address	Station number	Buffer memory address	Station number	Buffer memory address	Station number	Buffer memory address	Station number	Buffer memory address
1	160 <sub>H</sub> to 161 <sub>H</sub>	14	17A <sub>H</sub> to 17B <sub>H</sub>	27	194 <sub>H</sub> to 195 <sub>H</sub>	40	1AE <sub>H</sub> to 1AF <sub>H</sub>	53	1C8 <sub>H</sub> to 1C9 <sub>H</sub>
2	162 <sub>H</sub> to 163 <sub>H</sub>	15	17C <sub>H</sub> to 17D <sub>H</sub>	28	196 <sub>H</sub> to 197 <sub>H</sub>	41	1B0 <sub>H</sub> to 1B1 <sub>H</sub>	54	1CA <sub>H</sub> to 1CB <sub>H</sub>
3	164 <sub>H</sub> to 165 <sub>H</sub>	16	17E <sub>H</sub> to 17F <sub>H</sub>	29	198 <sub>H</sub> to 199 <sub>H</sub>	42	1B2 <sub>H</sub> to 1B3 <sub>H</sub>	55	1CC <sub>H</sub> to 1CD <sub>H</sub>
4	166 <sub>H</sub> to 167 <sub>H</sub>	17	180 <sub>H</sub> to 181 <sub>H</sub>	30	19A <sub>H</sub> to 19B <sub>H</sub>	43	1B4 <sub>H</sub> to 1B5 <sub>H</sub>	56	1CE <sub>H</sub> to 1CF <sub>H</sub>
5	168 <sub>H</sub> to 169 <sub>H</sub>	18	182 <sub>H</sub> to 183 <sub>H</sub>	31	19C <sub>H</sub> to 19D <sub>H</sub>	44	1B6 <sub>H</sub> to 1B7 <sub>H</sub>	57	1D0 <sub>H</sub> to 1D1 <sub>H</sub>
6	16A <sub>H</sub> to 16B <sub>H</sub>	19	184 <sub>H</sub> to 185 <sub>H</sub>	32	19E <sub>H</sub> to 19F <sub>H</sub>	45	1B8 <sub>H</sub> to 1B9 <sub>H</sub>	58	1D2 <sub>H</sub> to 1D3 <sub>H</sub>
7	16C <sub>H</sub> to 16D <sub>H</sub>	20	186 <sub>H</sub> to 187 <sub>H</sub>	33	1A0 <sub>H</sub> to 1A1 <sub>H</sub>	46	1BA <sub>H</sub> to 1BB <sub>H</sub>	59	1D4 <sub>H</sub> to 1D5 <sub>H</sub>
8	16E <sub>H</sub> to 16F <sub>H</sub>	21	188 <sub>H</sub> to 189 <sub>H</sub>	34	1A2 <sub>H</sub> to 1A3 <sub>H</sub>	47	1BC <sub>H</sub> to 1BD <sub>H</sub>	60	1D6 <sub>H</sub> to 1D7 <sub>H</sub>
9	170 <sub>H</sub> to 171 <sub>H</sub>	22	18A <sub>H</sub> to 18B <sub>H</sub>	35	1A4 <sub>H</sub> to 1A5 <sub>H</sub>	48	1BE <sub>H</sub> to 1BF <sub>H</sub>	61	1D8 <sub>H</sub> to 1D9 <sub>H</sub>
10	172 <sub>H</sub> to 173 <sub>H</sub>	23	18C <sub>H</sub> to 18D <sub>H</sub>	36	1A6 <sub>H</sub> to 1A7 <sub>H</sub>	49	1C0 <sub>H</sub> to 1C1 <sub>H</sub>	62	1DA <sub>H</sub> to 1DB <sub>H</sub>
11	174 <sub>H</sub> to 175 <sub>H</sub>	24	18E <sub>H</sub> to 18F <sub>H</sub>	37	1A8 <sub>H</sub> to 1A9 <sub>H</sub>	50	1C2 <sub>H</sub> to 1C3 <sub>H</sub>	63	1DC <sub>H</sub> to 1DD <sub>H</sub>
12	176 <sub>H</sub> to 177 <sub>H</sub>	25	190 <sub>H</sub> to 191 <sub>H</sub>	38	1AA <sub>H</sub> to 1AB <sub>H</sub>	51	1C4 <sub>H</sub> to 1C5 <sub>H</sub>	64	1DE <sub>H</sub> to 1DF <sub>H</sub>
13	178 <sub>H</sub> to 179 <sub>H</sub>	26	192 <sub>H</sub> to 193 <sub>H</sub>	39	1AC <sub>H</sub> to 1AD <sub>H</sub>	52	1C6 <sub>H</sub> to 1C7 <sub>H</sub>	—	—

[Local station]

Table of station numbers and corresponding buffer memory addresses

Station number	Buffer memory address	Station number	Buffer memory address	Station number	Buffer memory address	Station number	Buffer memory address	Station number	Buffer memory address
1	E0 <sub>H</sub> to E1 <sub>H</sub>	14	FA <sub>H</sub> to FB <sub>H</sub>	27	114 <sub>H</sub> to 115 <sub>H</sub>	40	12E <sub>H</sub> to 12F <sub>H</sub>	53	148 <sub>H</sub> to 149 <sub>H</sub>
2	E2 <sub>H</sub> to E3 <sub>H</sub>	15	FC <sub>H</sub> to FD <sub>H</sub>	28	116 <sub>H</sub> to 117 <sub>H</sub>	41	130 <sub>H</sub> to 131 <sub>H</sub>	54	14A <sub>H</sub> to 14B <sub>H</sub>
3	E4 <sub>H</sub> to E5 <sub>H</sub>	16	FE <sub>H</sub> to FF <sub>H</sub>	29	118 <sub>H</sub> to 119 <sub>H</sub>	42	132 <sub>H</sub> to 133 <sub>H</sub>	55	14C <sub>H</sub> to 14D <sub>H</sub>
4	E6 <sub>H</sub> to E7 <sub>H</sub>	17	100 <sub>H</sub> to 101 <sub>H</sub>	30	11A <sub>H</sub> to 11B <sub>H</sub>	43	134 <sub>H</sub> to 135 <sub>H</sub>	56	14E <sub>H</sub> to 14F <sub>H</sub>
5	E8 <sub>H</sub> to E9 <sub>H</sub>	18	102 <sub>H</sub> to 103 <sub>H</sub>	31	11C <sub>H</sub> to 11D <sub>H</sub>	44	136 <sub>H</sub> to 137 <sub>H</sub>	57	150 <sub>H</sub> to 151 <sub>H</sub>
6	EA <sub>H</sub> to EB <sub>H</sub>	19	104 <sub>H</sub> to 105 <sub>H</sub>	32	11E <sub>H</sub> to 11F <sub>H</sub>	45	138 <sub>H</sub> to 139 <sub>H</sub>	58	152 <sub>H</sub> to 153 <sub>H</sub>
7	EC <sub>H</sub> to ED <sub>H</sub>	20	106 <sub>H</sub> to 107 <sub>H</sub>	33	120 <sub>H</sub> to 121 <sub>H</sub>	46	13A <sub>H</sub> to 13B <sub>H</sub>	59	154 <sub>H</sub> to 155 <sub>H</sub>
8	EE <sub>H</sub> to EF <sub>H</sub>	21	108 <sub>H</sub> to 109 <sub>H</sub>	34	122 <sub>H</sub> to 123 <sub>H</sub>	47	13C <sub>H</sub> to 13D <sub>H</sub>	60	156 <sub>H</sub> to 157 <sub>H</sub>
9	F0 <sub>H</sub> to F1 <sub>H</sub>	22	10A <sub>H</sub> to 10B <sub>H</sub>	35	124 <sub>H</sub> to 125 <sub>H</sub>	48	13E <sub>H</sub> to 13F <sub>H</sub>	61	158 <sub>H</sub> to 159 <sub>H</sub>
10	F2 <sub>H</sub> to F3 <sub>H</sub>	23	10C <sub>H</sub> to 10D <sub>H</sub>	36	126 <sub>H</sub> to 127 <sub>H</sub>	49	140 <sub>H</sub> to 141 <sub>H</sub>	62	15A <sub>H</sub> to 15B <sub>H</sub>
11	F4 <sub>H</sub> to F5 <sub>H</sub>	24	10E <sub>H</sub> to 10F <sub>H</sub>	37	128 <sub>H</sub> to 129 <sub>H</sub>	50	142 <sub>H</sub> to 143 <sub>H</sub>	63	15C <sub>H</sub> to 15D <sub>H</sub>
12	F6 <sub>H</sub> to F7 <sub>H</sub>	25	110 <sub>H</sub> to 111 <sub>H</sub>	38	12A <sub>H</sub> to 12B <sub>H</sub>	51	144 <sub>H</sub> to 145 <sub>H</sub>	64	15E <sub>H</sub> to 15F <sub>H</sub>
13	F8 <sub>H</sub> to F9 <sub>H</sub>	26	112 <sub>H</sub> to 113 <sub>H</sub>	39	12C <sub>H</sub> to 12D <sub>H</sub>	52	146 <sub>H</sub> to 147 <sub>H</sub>	—	—

### (3) Remote registers (RWw) and (RWr)

Used when the remote net ver.1 mode or remote net additional mode is selected.

#### (a) Master station (RWw) → remote device station (RWw)/local station (RWr)

- Master station
  - The data to be sent to the remote register (RWw) of the remote device station and the remote registers (RWr) of all local stations are stored.
  - Four words are used per station.
- Local station
  - The data sent to the remote register (RWw) of the remote device station can also be received.
  - Four words are used per station.

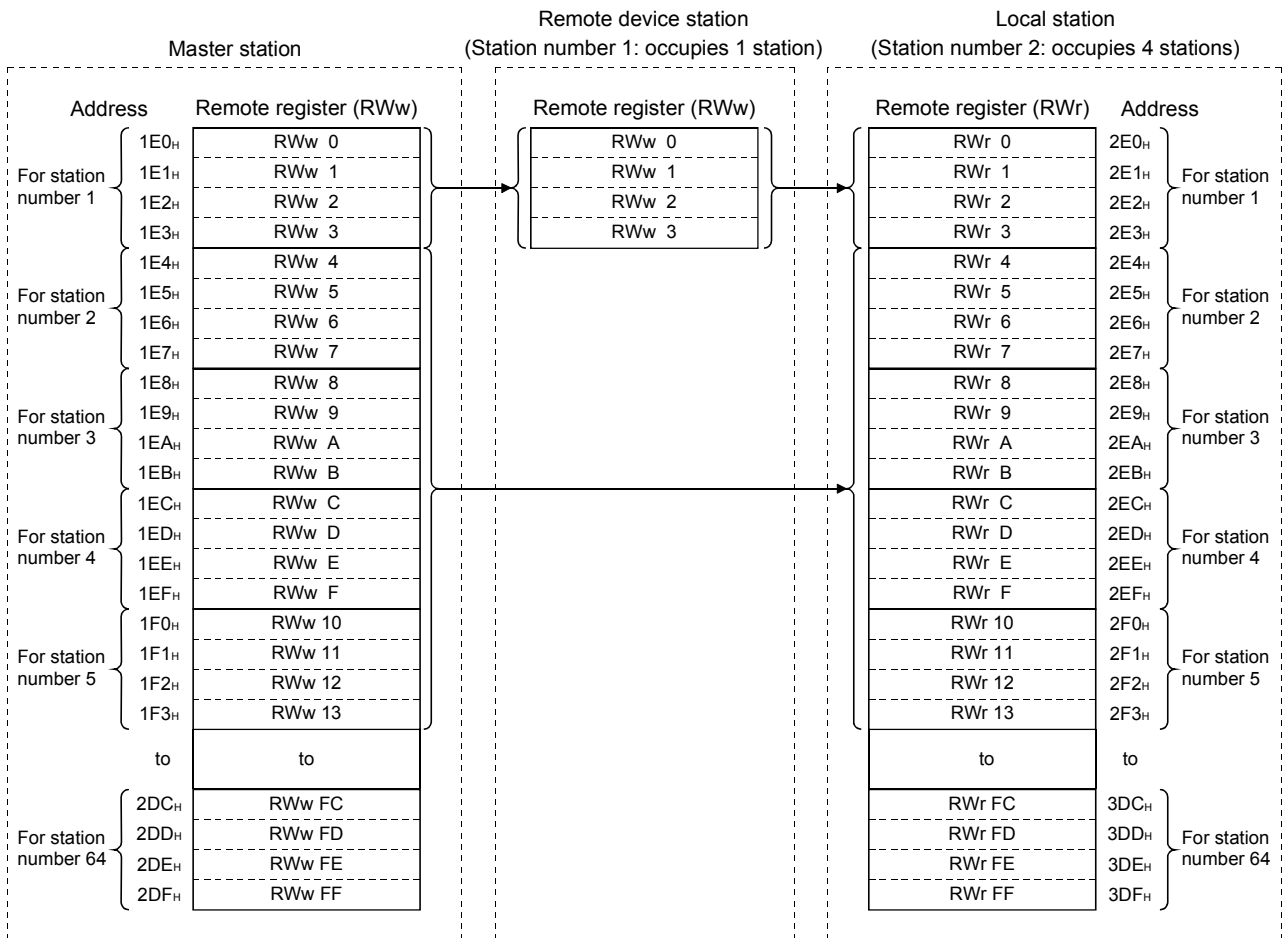

**(b) Master station (RW<sub>r</sub>) ← remote device station (RW<sub>r</sub>)/local station (RW<sub>w</sub>)**

- Master station
  - The send data from the remote register (RW<sub>r</sub>) of the remote device station and the remote register (RW<sub>w</sub>) of the local station is stored.
  - Four words are used per station.
- Local station
  - Data is sent to the master station and other local stations by storing it in the address corresponding to the host station number.
  - Data in the remote register (RW<sub>r</sub>) of the remote device station can also be received.
  - Four words are used per station.

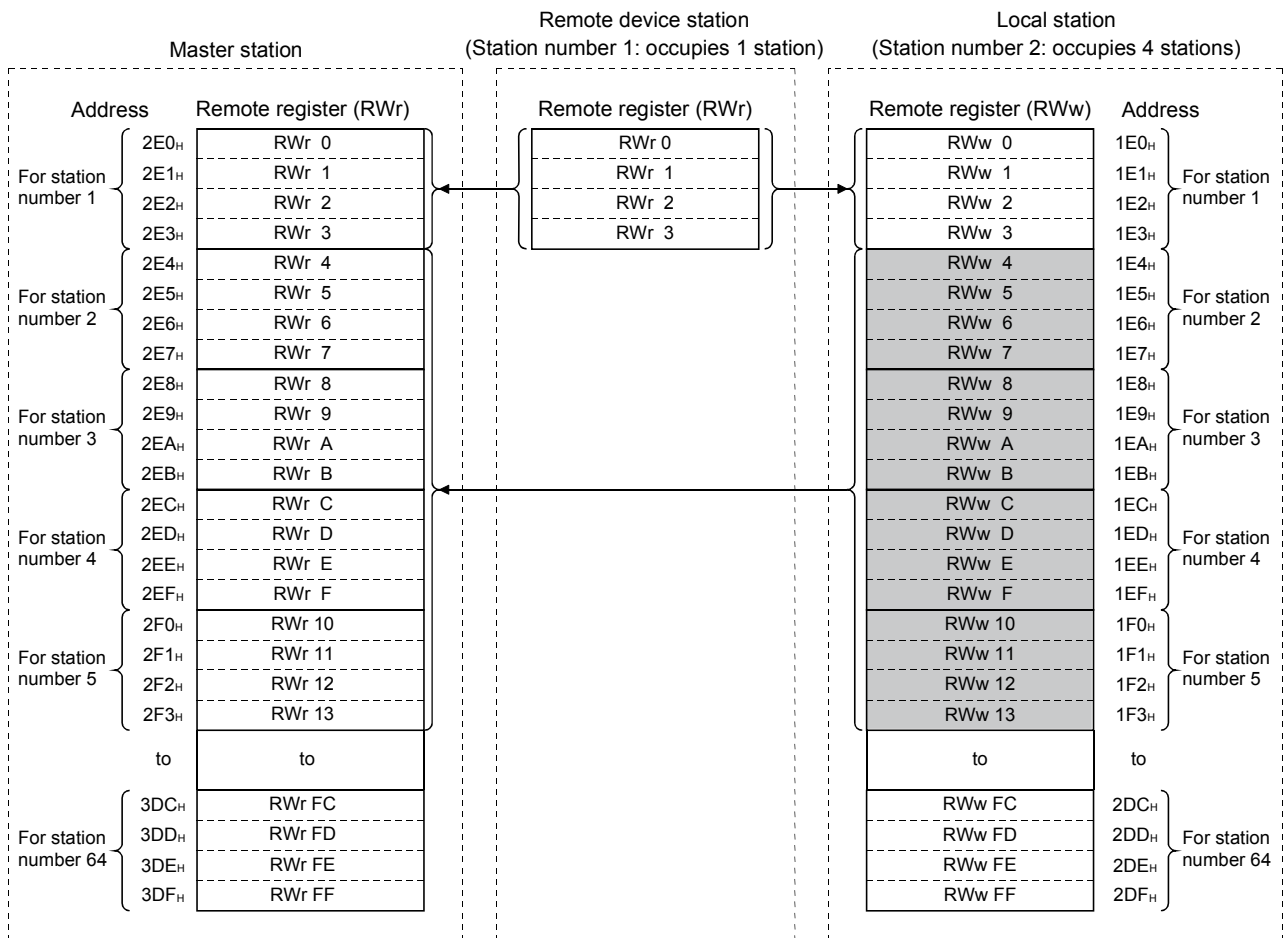

The following tables show the station numbers and corresponding buffer memory addresses.

[Master station]

Table of station numbers and corresponding buffer memory addresses

Station number	Buffer memory address	Station number	Buffer memory address	Station number	Buffer memory address	Station number	Buffer memory address	Station number	Buffer memory address
1	2E0 <sub>H</sub> to 2E3 <sub>H</sub>	14	314 <sub>H</sub> to 317 <sub>H</sub>	27	348 <sub>H</sub> to 34B <sub>H</sub>	40	37C <sub>H</sub> to 37F <sub>H</sub>	53	3B0 <sub>H</sub> to 3B3 <sub>H</sub>
2	2E4 <sub>H</sub> to 2E7 <sub>H</sub>	15	318 <sub>H</sub> to 31B <sub>H</sub>	28	34C <sub>H</sub> to 34F <sub>H</sub>	41	380 <sub>H</sub> to 383 <sub>H</sub>	54	3B4 <sub>H</sub> to 3B7 <sub>H</sub>
3	2E8 <sub>H</sub> to 2EB <sub>H</sub>	16	31C <sub>H</sub> to 31F <sub>H</sub>	29	350 <sub>H</sub> to 353 <sub>H</sub>	42	384 <sub>H</sub> to 387 <sub>H</sub>	55	3B8 <sub>H</sub> to 3BB <sub>H</sub>
4	2EC <sub>H</sub> to 2EF <sub>H</sub>	17	320 <sub>H</sub> to 323 <sub>H</sub>	30	354 <sub>H</sub> to 357 <sub>H</sub>	43	388 <sub>H</sub> to 38B <sub>H</sub>	56	3BC <sub>H</sub> to 3BF <sub>H</sub>
5	2F0 <sub>H</sub> to 2F3 <sub>H</sub>	18	324 <sub>H</sub> to 327 <sub>H</sub>	31	358 <sub>H</sub> to 35B <sub>H</sub>	44	38C <sub>H</sub> to 38F <sub>H</sub>	57	3C0 <sub>H</sub> to 3C3 <sub>H</sub>
6	2F4 <sub>H</sub> to 2F7 <sub>H</sub>	19	328 <sub>H</sub> to 32B <sub>H</sub>	32	35C <sub>H</sub> to 35F <sub>H</sub>	45	390 <sub>H</sub> to 393 <sub>H</sub>	58	3C4 <sub>H</sub> to 3C7 <sub>H</sub>
7	2F8 <sub>H</sub> to 2FB <sub>H</sub>	20	32C <sub>H</sub> to 32F <sub>H</sub>	33	360 <sub>H</sub> to 363 <sub>H</sub>	46	394 <sub>H</sub> to 397 <sub>H</sub>	59	3C8 <sub>H</sub> to 3CB <sub>H</sub>
8	2FC <sub>H</sub> to 2FF <sub>H</sub>	21	330 <sub>H</sub> to 333 <sub>H</sub>	34	364 <sub>H</sub> to 367 <sub>H</sub>	47	398 <sub>H</sub> to 39B <sub>H</sub>	60	3CC <sub>H</sub> to 3CF <sub>H</sub>
9	300 <sub>H</sub> to 303 <sub>H</sub>	22	334 <sub>H</sub> to 337 <sub>H</sub>	35	368 <sub>H</sub> to 36B <sub>H</sub>	48	39C <sub>H</sub> to 39F <sub>H</sub>	61	3D0 <sub>H</sub> to 3D3 <sub>H</sub>
10	304 <sub>H</sub> to 307 <sub>H</sub>	23	338 <sub>H</sub> to 33B <sub>H</sub>	36	36C <sub>H</sub> to 36F <sub>H</sub>	49	3A0 <sub>H</sub> to 3A3 <sub>H</sub>	62	3D4 <sub>H</sub> to 3D7 <sub>H</sub>
11	308 <sub>H</sub> to 30B <sub>H</sub>	24	33C <sub>H</sub> to 33F <sub>H</sub>	37	370 <sub>H</sub> to 373 <sub>H</sub>	50	3A4 <sub>H</sub> to 3A7 <sub>H</sub>	63	3D8 <sub>H</sub> to 3DB <sub>H</sub>
12	30C <sub>H</sub> to 30F <sub>H</sub>	25	340 <sub>H</sub> to 343 <sub>H</sub>	38	374 <sub>H</sub> to 377 <sub>H</sub>	51	3A8 <sub>H</sub> to 3AB <sub>H</sub>	64	3DC <sub>H</sub> to 3DF <sub>H</sub>
13	310 <sub>H</sub> to 313 <sub>H</sub>	26	344 <sub>H</sub> to 347 <sub>H</sub>	39	378 <sub>H</sub> to 37B <sub>H</sub>	52	3AC <sub>H</sub> to 3AF <sub>H</sub>	—	—

[Local station]

Table of station numbers and corresponding buffer memory addresses

Station number	Buffer memory address	Station number	Buffer memory address	Station number	Buffer memory address	Station number	Buffer memory address	Station number	Buffer memory address
1	1E0 <sub>H</sub> to 1E3 <sub>H</sub>	14	214 <sub>H</sub> to 217 <sub>H</sub>	27	248 <sub>H</sub> to 24B <sub>H</sub>	40	27C <sub>H</sub> to 27F <sub>H</sub>	53	2B0 <sub>H</sub> to 2B3 <sub>H</sub>
2	1E4 <sub>H</sub> to 1E7 <sub>H</sub>	15	218 <sub>H</sub> to 21B <sub>H</sub>	28	24C <sub>H</sub> to 24F <sub>H</sub>	41	280 <sub>H</sub> to 283 <sub>H</sub>	54	2B4 <sub>H</sub> to 2B7 <sub>H</sub>
3	1E8 <sub>H</sub> to 1EB <sub>H</sub>	16	21C <sub>H</sub> to 21F <sub>H</sub>	29	250 <sub>H</sub> to 253 <sub>H</sub>	42	284 <sub>H</sub> to 287 <sub>H</sub>	55	2B8 <sub>H</sub> to 2BB <sub>H</sub>
4	1EC <sub>H</sub> to 1EF <sub>H</sub>	17	220 <sub>H</sub> to 223 <sub>H</sub>	30	254 <sub>H</sub> to 257 <sub>H</sub>	43	288 <sub>H</sub> to 28B <sub>H</sub>	56	2BC <sub>H</sub> to 2BF <sub>H</sub>
5	1F0 <sub>H</sub> to 1F3 <sub>H</sub>	18	224 <sub>H</sub> to 227 <sub>H</sub>	31	258 <sub>H</sub> to 25B <sub>H</sub>	44	28C <sub>H</sub> to 28F <sub>H</sub>	57	2C0 <sub>H</sub> to 2C3 <sub>H</sub>
6	1F4 <sub>H</sub> to 1F7 <sub>H</sub>	19	228 <sub>H</sub> to 22B <sub>H</sub>	32	25C <sub>H</sub> to 25F <sub>H</sub>	45	290 <sub>H</sub> to 293 <sub>H</sub>	58	2C4 <sub>H</sub> to 2C7 <sub>H</sub>
7	1F8 <sub>H</sub> to 1FB <sub>H</sub>	20	22C <sub>H</sub> to 22F <sub>H</sub>	33	260 <sub>H</sub> to 263 <sub>H</sub>	46	294 <sub>H</sub> to 297 <sub>H</sub>	59	2C8 <sub>H</sub> to 2CB <sub>H</sub>
8	1FC <sub>H</sub> to 1FF <sub>H</sub>	21	230 <sub>H</sub> to 233 <sub>H</sub>	34	264 <sub>H</sub> to 267 <sub>H</sub>	47	298 <sub>H</sub> to 29B <sub>H</sub>	60	2CC <sub>H</sub> to 2CF <sub>H</sub>
9	200 <sub>H</sub> to 203 <sub>H</sub>	22	234 <sub>H</sub> to 237 <sub>H</sub>	35	268 <sub>H</sub> to 26B <sub>H</sub>	48	29C <sub>H</sub> to 29F <sub>H</sub>	61	2D0 <sub>H</sub> to 2D3 <sub>H</sub>
10	204 <sub>H</sub> to 207 <sub>H</sub>	23	238 <sub>H</sub> to 23B <sub>H</sub>	36	26C <sub>H</sub> to 26F <sub>H</sub>	49	2A0 <sub>H</sub> to 2A3 <sub>H</sub>	62	2D4 <sub>H</sub> to 2D7 <sub>H</sub>
11	208 <sub>H</sub> to 20B <sub>H</sub>	24	23C <sub>H</sub> to 23F <sub>H</sub>	37	270 <sub>H</sub> to 273 <sub>H</sub>	50	2A4 <sub>H</sub> to 2A7 <sub>H</sub>	63	2D8 <sub>H</sub> to 2DB <sub>H</sub>
12	20C <sub>H</sub> to 20F <sub>H</sub>	25	240 <sub>H</sub> to 243 <sub>H</sub>	38	274 <sub>H</sub> to 277 <sub>H</sub>	51	2A8 <sub>H</sub> to 2AB <sub>H</sub>	64	2DC <sub>H</sub> to 2DF <sub>H</sub>
13	210 <sub>H</sub> to 213 <sub>H</sub>	26	244 <sub>H</sub> to 247 <sub>H</sub>	39	278 <sub>H</sub> to 27B <sub>H</sub>	52	2AC <sub>H</sub> to 2AF <sub>H</sub>	—	—

#### (4) Slave station offset, size information

In the remote net ver.2 mode or remote net additional mode, the assignment of RX/RX/RWw/RWr for the station numbers varies according to the expanded cyclic setting and remote I/O station points setting.

##### (a) Offset

Stores the head buffer memory address of RX/RX/RWw/RWr assigned to each station.

When 2 or more stations are occupied, values are stored into only the head buffer memory address of the station number. (When station No. 1 occupies 2 stations, values are stored into the RX/RX/RWw/RWr offset and size of station No. 1, and the RX/RX/RWw/RWr offset and size of station No. 2 remains default.)

##### (b) Size

Stores the size of RX/RX/RWw/RWr assigned to each station in word unit.

When the size is less than 1 word, it is rounded up and 1 is stored. (When the remote I/O station points setting is 8 points, 1 is stored.)

Refer to  Page 188, Section 8.3.9 for the remote I/O station points setting method.

For the reserved station, 0000<sub>H</sub> is stored.

The following table lists the correspondence between station numbers and the buffer memory address of RX/RX/RWw/RWr offset and size.

Buffer memory address		Item	Default (Hex.)
Hex.	Dec.		
3E0 <sub>H</sub>	992	Station No. 1 RX offset	0000 <sub>H</sub>
3E1 <sub>H</sub>	993	Station No. 1 RX size	0000 <sub>H</sub>
⋮	⋮	⋮	—
45E <sub>H</sub>	1118	Station No. 64 RX offset	0000 <sub>H</sub>
45F <sub>H</sub>	1119	Station No. 64 RX size	0000 <sub>H</sub>
460 <sub>H</sub>	1120	Station No. 1 RY offset	0000 <sub>H</sub>
461 <sub>H</sub>	1121	Station No. 1 RY size	0000 <sub>H</sub>
⋮	⋮	⋮	—
4DE <sub>H</sub>	1246	Station No. 64 RY offset	0000 <sub>H</sub>
4DF <sub>H</sub>	1247	Station No. 64 RY size	0000 <sub>H</sub>
4E0 <sub>H</sub>	1248	Station No. 1 RWw offset	0000 <sub>H</sub>
4E1 <sub>H</sub>	1249	Station No. 1 RWw size	0000 <sub>H</sub>
⋮	⋮	⋮	—
55E <sub>H</sub>	1374	Station No. 64 RWw offset	0000 <sub>H</sub>
55F <sub>H</sub>	1375	Station No. 64 RWw size	0000 <sub>H</sub>
560 <sub>H</sub>	1376	Station No. 1 RWr offset	0000 <sub>H</sub>
561 <sub>H</sub>	1377	Station No. 1 RWr size	0000 <sub>H</sub>
⋮	⋮	⋮	—
5DE <sub>H</sub>	1502	Station No. 64 RWr offset	0000 <sub>H</sub>
5DF <sub>H</sub>	1503	Station No. 64 RWr size	0000 <sub>H</sub>

**Ex** When the local station where expanded cyclic setting has been made and the remote I/O stations where remote I/O station points setting has been made are connected

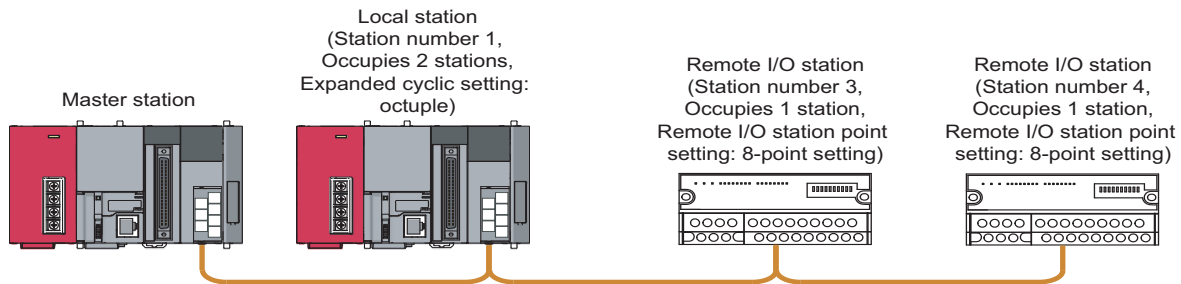

Buffer memory name	Value	Description
Station No. 1 RX offset	4000 <sub>H</sub>	Head buffer memory address of RX of station No. 1
Station No. 1 RX size	24 (18 <sub>H</sub> )	384 (number of RX points) / 16 = 24 words
Station No. 2 RX offset	4000 <sub>H</sub>	As 2 stations are occupied, the area of station No. 1 is checked.
Station No. 2 RX size	0 (default)	As 2 stations are occupied, the area of station No. 1 is checked.
Station No. 3 RX offset	4018 <sub>H</sub>	Head buffer memory address of RX of station No. 3
Station No. 3 RX size	1 (1 <sub>H</sub> )	Though the lower 8 bits of the buffer memory address 4018 <sub>H</sub> are the corresponding size of RX of station No. 3, 1 is stored since less than 1 word is rounded up.
Station No. 4 RX offset	4018 <sub>H</sub>	Head buffer memory address of RX of station No. 4
Station No. 4 RX size	1 (1 <sub>H</sub> )	Though the upper 8 bits of the buffer memory address 4018 <sub>H</sub> are the corresponding size of RX of station No. 4, 1 is stored since less than 1 word is rounded up.
Station No. 1 RY offset	4200 <sub>H</sub>	Head buffer memory address of RY of station No. 1
Station No. 1 RY size	24 (18 <sub>H</sub> )	384 (number of RY points) / 16 = 24 words
Station No. 2 RY offset	4200 <sub>H</sub>	As 2 stations are occupied, the area of station No. 1 is checked.
Station No. 2 RY size	0 (default)	As 2 stations are occupied, the area of station No. 1 is checked.
Station No. 3 RY offset	4218 <sub>H</sub>	Head buffer memory address of RY of station No. 3
Station No. 3 RY size	1 (1 <sub>H</sub> )	Though the lower 8 bits of the buffer memory address 4218 <sub>H</sub> are the corresponding size of RY of station No. 3, 1 is stored since less than 1 word is rounded up.
Station No. 4 RY offset	4218 <sub>H</sub>	Head buffer memory address of RY of station No. 4
Station No. 4 RY size	1 (18 <sub>H</sub> )	Though the upper 8 bits of the buffer memory address 4218 <sub>H</sub> are the corresponding size of RY of station No. 4, 1 is stored since less than 1 word is rounded up.
Station No. 1 RWw offset	4400 <sub>H</sub>	Head buffer memory address of RWw of station No. 1
Station No. 1 RWw size	64 (40 <sub>H</sub> )	2 (number of occupied stations) × 32 (expanded cyclic setting) = 64
Station No. 2 RWw offset	4400 <sub>H</sub>	As 2 stations are occupied, the area of station No. 1 is checked.
Station No. 2 RWw size	0 (default)	As 2 stations are occupied, the area of station No. 1 is checked.
Station No. 3 RWw offset	4440 <sub>H</sub>	Head buffer memory address of RWw of station No. 3
Station No. 3 RWw size	0 (default)	Buffer memory size of RWw of station No. 3
Station No. 4 RWw offset	4440 <sub>H</sub>	Head buffer memory address of RWw of station No. 4
Station No. 4 RWw size	0 (default)	Buffer memory size of RWw of station No. 4
Station No. 1 RWr offset	4C00 <sub>H</sub>	Head buffer memory address of RWr of station No. 1
Station No. 1 RWr size	64 (40 <sub>H</sub> )	2 (number of occupied stations) × 32 (expanded cyclic setting) = 64
Station No. 2 RWr offset	4C00 <sub>H</sub>	As 2 stations are occupied, the area of station No. 1 is checked.
Station No. 2 RWr size	0 (default)	As 2 stations are occupied, the area of station No. 1 is checked.
Station No. 3 RWr offset	4C40 <sub>H</sub>	Head buffer memory address of RWr of station No. 3
Station No. 3 RWr size	0 (default)	Buffer memory size of RWr of station No. 3

Buffer memory name	Value	Description
Station No. 4 RWr offset	4C40 <sub>H</sub>	Head buffer memory address of RWr of station No. 4
Station No. 4 RWr size	0 (default)	Buffer memory size of RWr of station No. 4

**A**

## (5) Link special relays (SB)

The link special relays store the data link status using bit ON/OFF data.

Buffer memory addresses 5E0<sub>H</sub> to 5FF<sub>H</sub> correspond to link special relays SB0000 to SB01FF.

For details on the link special relays (SB0000 to SB01FF), refer to  Page 410, Appendix 3.1.

The following table shows the relationship between buffer memory addresses 5E0<sub>H</sub> to 5FF<sub>H</sub> and link special relays SB0000 to SB01FF.

Address	b15	b14	b13	b12	b11	b10	b9	b8	b7	b6	b5	b4	b3	b2	b1	b0
5E0 <sub>H</sub>	F	E	D	C	B	A	9	8	7	6	5	4	3	2	1	0
5E1 <sub>H</sub>	1F	1E	1D	1C	1B	1A	19	18	17	16	15	14	13	12	11	10
5E2 <sub>H</sub>	2F	2E	2D	2C	2B	2A	29	28	27	26	25	24	23	22	21	20
5E3 <sub>H</sub>	3F	3E	3D	3C	3B	3A	39	38	37	36	35	34	33	32	31	30
5E4 <sub>H</sub>	4F	4E	4D	4C	4B	4A	49	48	47	46	45	44	43	42	41	40
5E5 <sub>H</sub>	5F	5E	5D	5C	5B	5A	59	58	57	56	55	54	53	52	51	50
5E6 <sub>H</sub>	6F	6E	6D	6C	6B	6A	69	68	67	66	65	64	63	62	61	60
5E7 <sub>H</sub>	7F	7E	7D	7C	7B	7A	79	78	77	76	75	74	73	72	71	70
5E8 <sub>H</sub>	8F	8E	8D	8C	8B	8A	89	88	87	86	85	84	83	82	81	80
5E9 <sub>H</sub>	9F	9E	9D	9C	9B	9A	99	98	97	96	95	94	93	92	91	90
5EA <sub>H</sub>	AF	AE	AD	AC	AB	AA	A9	A8	A7	A6	A5	A4	A3	A2	A1	A0
5EB <sub>H</sub>	BF	BE	BD	BC	BB	BA	B9	B8	B7	B6	B5	B4	B3	B2	B1	B0
5EC <sub>H</sub>	CF	CE	CD	CC	CB	CA	C9	C8	C7	C6	C5	C4	C3	C2	C1	C0
5ED <sub>H</sub>	DF	DE	DD	DC	DB	DA	D9	D8	D7	D6	D5	D4	D3	D2	D1	D0
5EE <sub>H</sub>	EF	EE	ED	EC	EB	EA	E9	E8	E7	E6	E5	E4	E3	E2	E1	E0
5EF <sub>H</sub>	FF	FE	FD	FC	FB	FA	F9	F8	F7	F6	F5	F4	F3	F2	F1	F0
5F0 <sub>H</sub>	10F	10E	10D	10C	10B	10A	109	108	107	106	105	104	103	102	101	100
5F1 <sub>H</sub>	11F	11E	11D	11C	11B	11A	119	118	117	116	115	114	113	112	111	110
5F2 <sub>H</sub>	12F	12E	12D	12C	12B	12A	129	128	127	126	125	124	123	122	121	120
5F3 <sub>H</sub>	13F	13E	13D	13C	13B	13A	139	138	137	136	135	134	133	132	131	130
5F4 <sub>H</sub>	14F	14E	14D	14C	14B	14A	149	148	147	146	145	144	143	142	141	140
5F5 <sub>H</sub>	15F	15E	15D	15C	15B	15A	159	158	157	156	155	154	153	152	151	150
5F6 <sub>H</sub>	16F	16E	16D	16C	16B	16A	169	168	167	166	165	164	163	162	161	160
5F7 <sub>H</sub>	17F	17E	17D	17C	17B	17A	179	178	177	176	175	174	173	172	171	170
5F8 <sub>H</sub>	18F	18E	18D	18C	18B	18A	189	188	187	186	185	184	183	182	181	180
5F9 <sub>H</sub>	19F	19E	19D	19C	19B	19A	199	198	197	196	195	194	193	192	191	190
5FA <sub>H</sub>	1AF	1AE	1AD	1AC	1AB	1AA	1A9	1A8	1A7	1A6	1A5	1A4	1A3	1A2	1A1	1A0
5FB <sub>H</sub>	1BF	1BE	1BD	1BC	1BB	1BA	1B9	1B8	1B7	1B6	1B5	1B4	1B3	1B2	1B1	1B0
5FC <sub>H</sub>	1CF	1CE	1CD	1CC	1CB	1CA	1C9	1C8	1C7	1C6	1C5	1C4	1C3	1C2	1C1	1C0
5FD <sub>H</sub>	1DF	1DE	1DD	1DC	1DB	1DA	1D9	1D8	1D7	1D6	1D5	1D4	1D3	1D2	1D1	1D0
5FE <sub>H</sub>	1EF	1EE	1ED	1EC	1EB	1EA	1E9	1E8	1E7	1E6	1E5	1E4	1E3	1E2	1E1	1E0
5FF <sub>H</sub>	1FF	1FE	1FD	1FC	1FB	1FA	1F9	1F8	1F7	1F6	1F5	1F4	1F3	1F2	1F1	1F0



## (6) Link special registers (SW)

The link special registers store the data link status using word data.

Buffer memory addresses 600<sub>H</sub> to 7FF<sub>H</sub> correspond to link special registers SW0000 to SW01FF.

For details on the link special registers (SW0000 to SW01FF), refer to  Page 416, Appendix 3.2.

## (7) Random access buffer

The random access buffer stores any data to be sent to other stations.

The reading and writing of data are performed using transient transmission.

## (8) Communication buffer

The communication buffers stores the send and receive data when performing transient transmission (communication using the communication buffers) between the local stations, standby master station, and intelligent device stations.

The communication buffer sizes for the local station, standby master station, and intelligent device station are set with network parameters.

For how to set the communication buffer size settings, refer to  Page 83, Section 7.3.2 (2).

[Example of communication using the communication buffers]

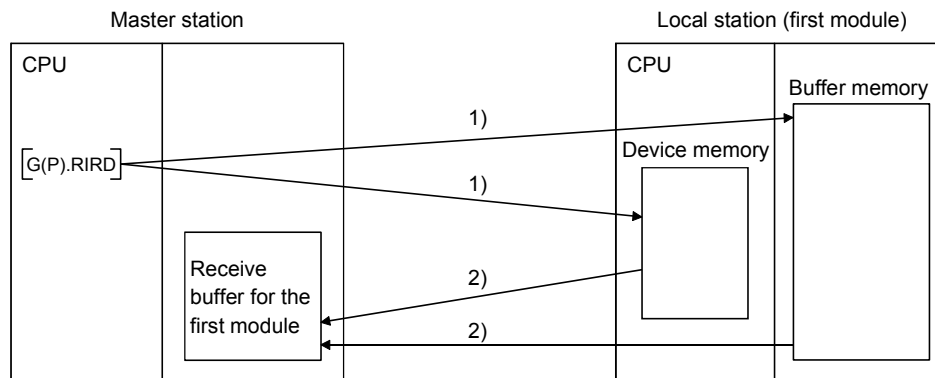

- 1) Accesses the buffer memory of the local station or the device memory of the CPU.
- 2) Stores the data specified by the control data in the receive buffer for the first module.

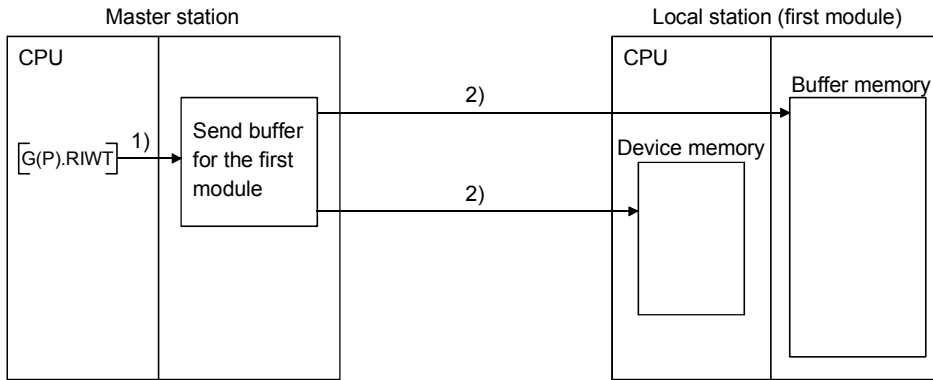

- 1) Stores the data to be written in the buffer memory of the local station or to the device memory of the CPU in the send buffer for the first module.
- 2) Accesses the buffer memory of the local station or the device memory of the CPU.

### (9) Automatic update buffer

The automatic update buffer stores automatic update data when performing transient transmission (communication using the automatic update buffer) with the AJ65BT-R2N.

The automatic update buffer size of the AJ65BT-R2N is specified by a network parameter.

For how to set the automatic update buffer size settings, refer to  Page 83, Section 7.3.2 (2).

[Communication example using the automatic update buffer]

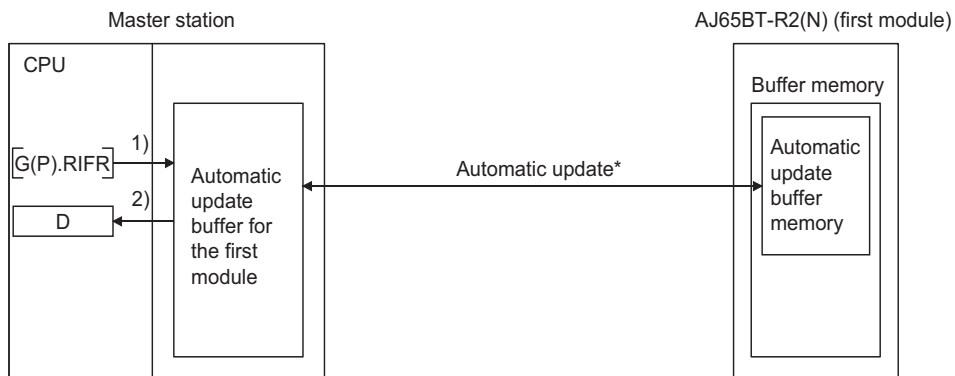



- 1) Accesses the automatic update buffer for the first module.
- 2) Stores the data specified by the control data in the CPU device.

\* For details on the automatic update timing, refer to  CC-Link System RS-232 Interface Module User's Manual (Nonprocedural Protocol Mode).

### (10) Ver.2 compatible remote input (RX) and Ver.2 compatible remote output (RY)

Used when the remote net ver.2 mode or remote net additional mode is selected.

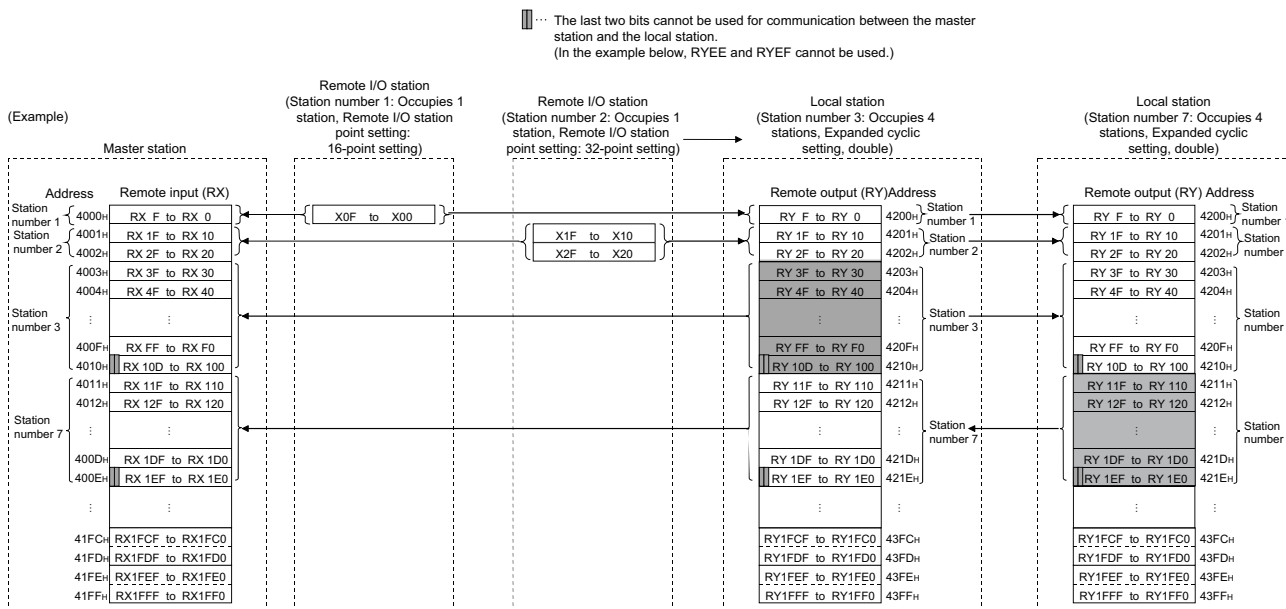

#### (a) Master station ← Remote I/O station/remote device station/local station

- Master station
  - The input status from the remote I/O station, remote device station (RX) and local station (RY) is stored.
  - When 1 station is occupied, 2, 4 or 8 words are used. The number of used points changes depending on the extended cyclic setting and the number of occupied stations. (Refer to  Page 26, Section 3.2)
- Local station
  - Data to be sent to the master station is stored in the remote output (RY) of the address corresponding to the host station number.
  - The input status from the remote I/O station, remote device station (RX) and other local station is stored.
  - When 1 station is occupied, any of 2 to 8 words are used. The number of used points changes depending on the extended cyclic setting and the number of occupied stations. (Refer to  Page 26, Section 3.2)



The assignment range of each station in the preset station information can be confirmed by the slave station offset and size information (buffer memory addresses 3E0<sub>H</sub> to 5DF<sub>H</sub>). (Refer to  Page 399, Appendix 2 (4).)

**(b) Master station → Remote I/O station/remote device station/local station**

- Master station
  - The output status to the remote I/O station, remote device station (RY) and all local stations (RX) is stored.
  - When 1 station is occupied, 2, 4 or 8 words are used. The number of used points changes depending on the extended cyclic setting and the number of occupied stations. (Refer to  Page 26, Section 3.2)
- Local station
  - The data received from remote I/O stations, remote device stations (RY) and master station (RY) are stored.
  - When 1 station is occupied, any of 2 to 8 words are used. The number of used points changes depending on the extended cyclic setting and the number of occupied stations. (Refer to  Page 26, Section 3.2)

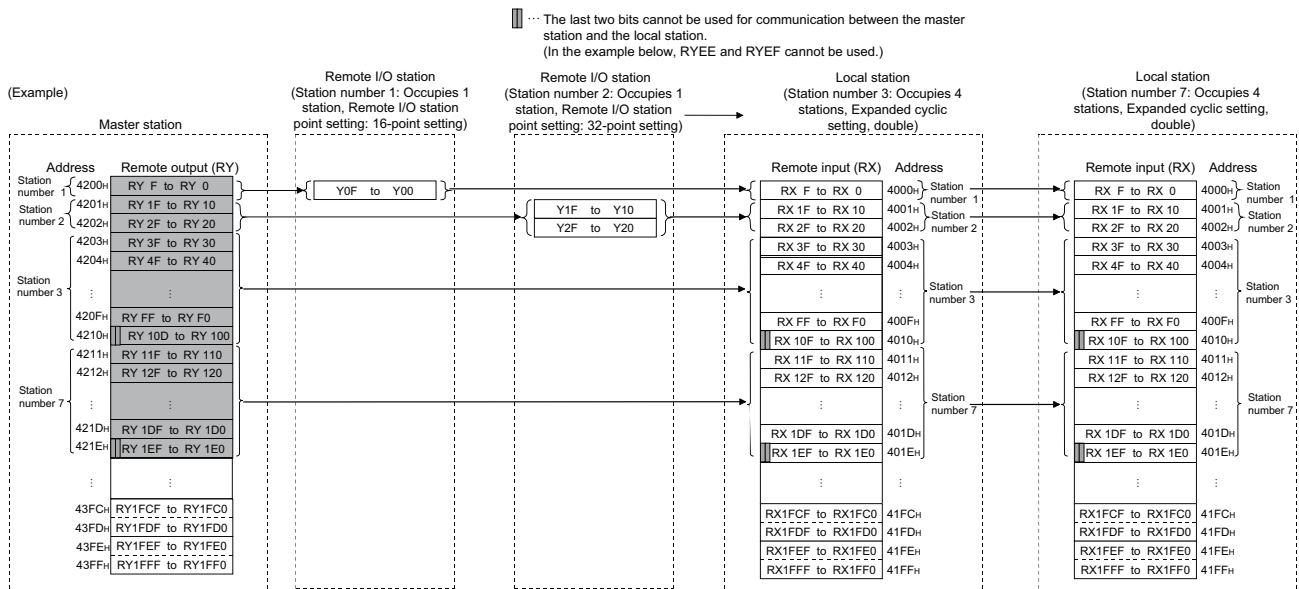



The assignment range of each station in the preset station information can be confirmed by the slave station offset and size information (buffer memory addresses 3E0<sub>H</sub> to 5DF<sub>H</sub>). (Refer to  Page 399, Appendix 2 (4).)

**(11) Ver.2 compatible remote registers (RWw) and (RWr)**

Used when the remote net ver.2 mode or remote net additional mode is selected.



**(a) Master station (RWw) → remote device station (RWw)/local station (RWr)**

- Master station
  - The data to be sent to the remote register (RWw) of the remote device station and the remote registers (RWr) of all local stations are stored.
  - When 1 station is occupied, any of 4 to 32 words are used. The number of used points changes depending on the expanded cyclic setting and the number of occupied stations. (Refer to  Page 26, Section 3.2)
- Local station
  - The data sent to the remote register (RWw) of the remote device station can also be received.
  - When 1 station is occupied, any of 4 to 32 words are used. The number of used points changes depending on the expanded cyclic setting and the number of occupied stations. (Refer to  Page 26, Section 3.2)

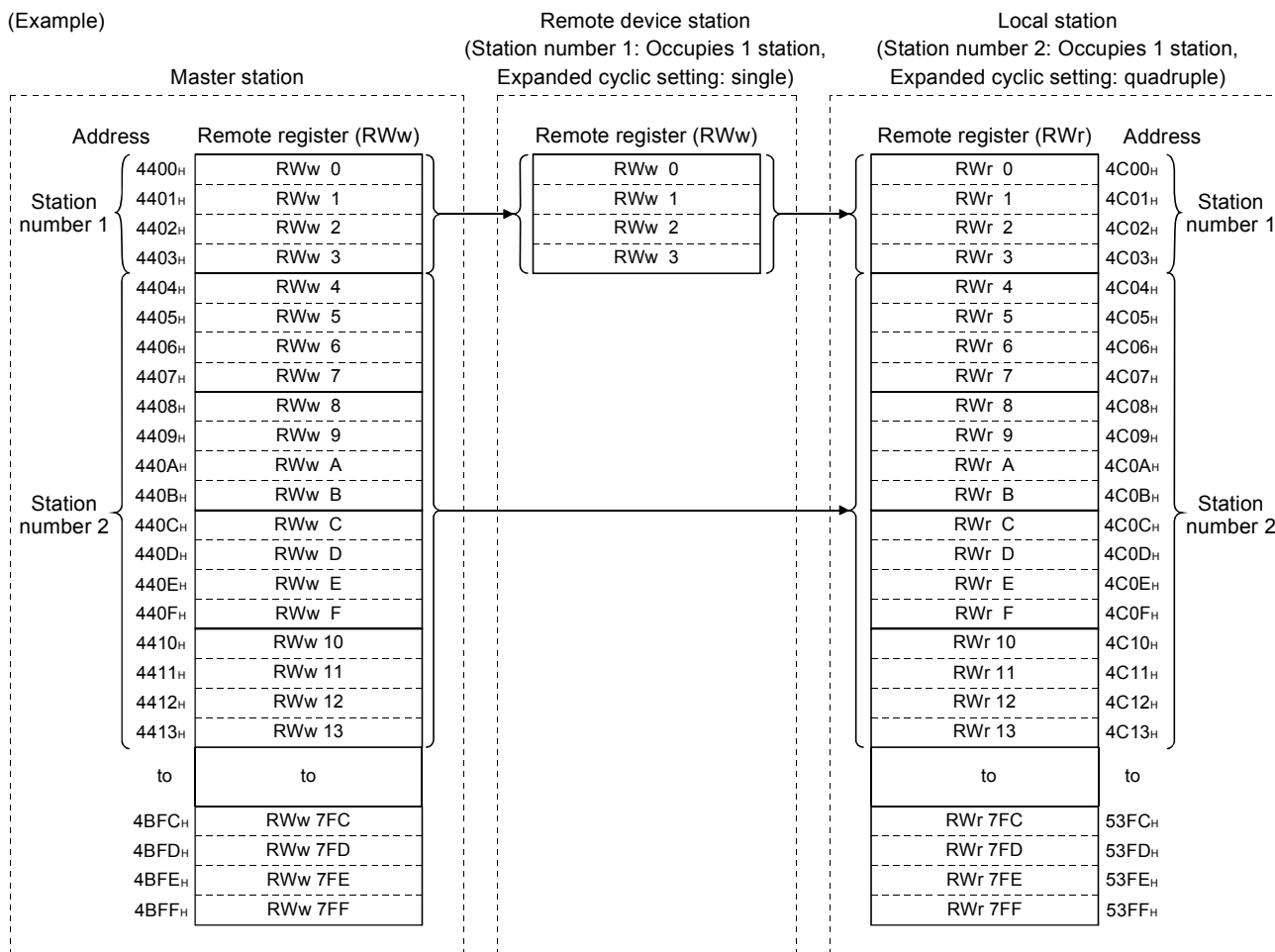
(Example)



**(b) Master station (RWr) ← remote device station (RWr)/local station (RWw)**

- Master station
  - The send data from the remote register (RWr) of the remote device station and the remote register (RWw) of the local station is stored.
  - When 1 station is occupied, any of 4 to 32 words are used. The number of used points changes depending on the expanded cyclic setting and the number of occupied stations. (Refer to  Page 26, Section 3.2)
- Local station
  - Data is sent to the master station and other local stations by storing it in the address corresponding to the host station number.
  - Data in the remote register (RWr) of the remote device station can also be received.
  - When 1 station is occupied, any of 4 to 32 words are used. The number of used points changes depending on the expanded cyclic setting and the number of occupied stations. (Refer to  Page 26, Section 3.2)

(Example)

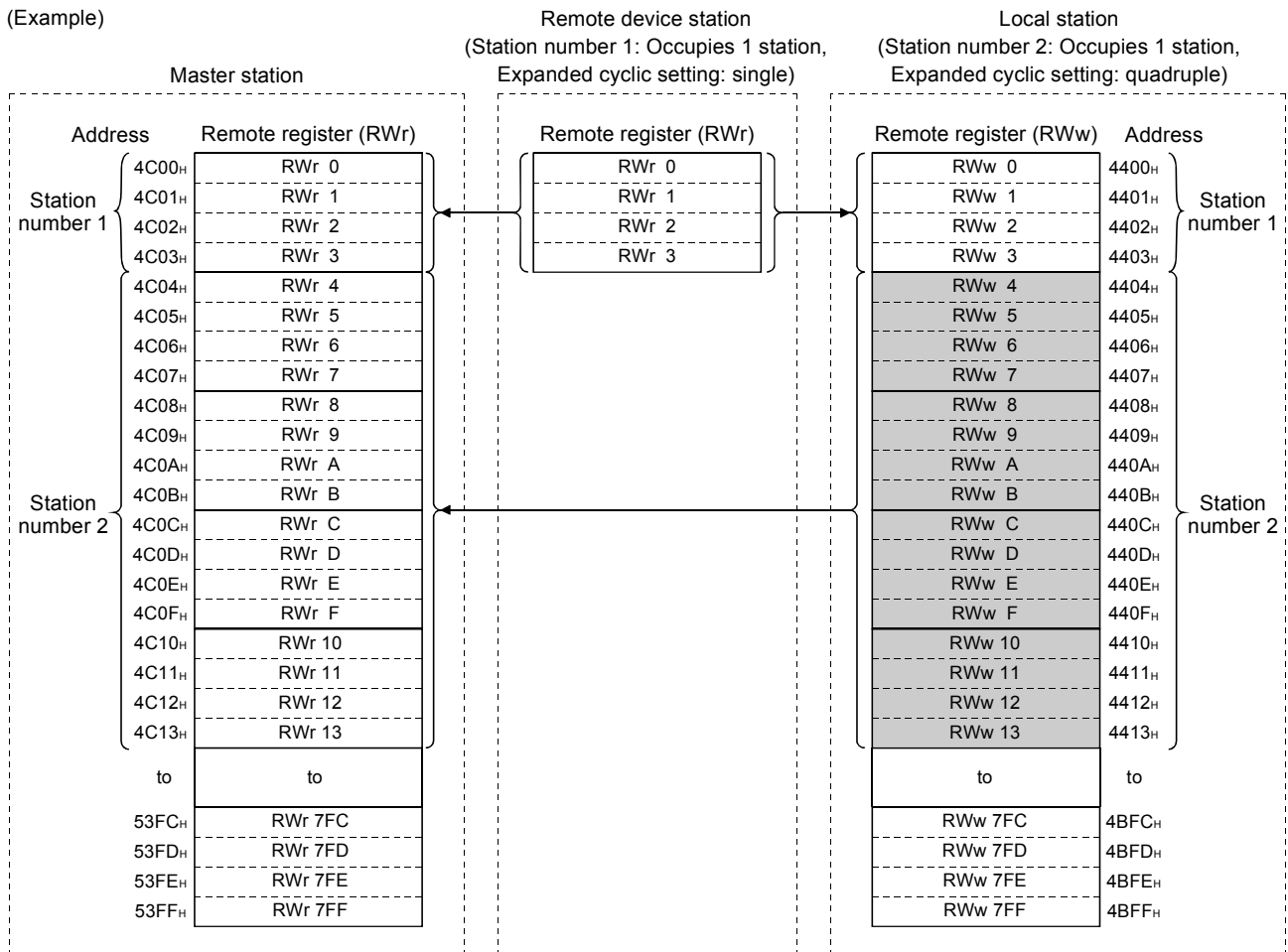

## Appendix 3 Link Special Relays and Registers (SB/SW)

---

A

The data link status can be checked with bit data (link special relays: SB) and word data (link special registers: SW). The SB and SW represent the information in the buffer memory of the L series master/local module, which is used by reading to the device specified in an automatic refresh parameter.

- Link special relays (SB): Buffer memory addresses 5E0<sub>H</sub> to 5FF<sub>H</sub>
- Link special registers (SW): Buffer memory addresses 600<sub>H</sub> to 7FF<sub>H</sub>

## Appendix 3.1 Link special relays (SB)

Link special relays SB0000 to SB001F are turned ON/OFF by the program, and SB0020 to SB01FF are turned ON/OFF by the L series master/local module.

The numeric values in parentheses in the Number column indicate addresses and bit positions of the buffer memory.

 Example: For buffer memory address 5E0<sub>H</sub> and bit 0: (5E0<sub>H</sub>, b0)

When a standby master station is used as a standby master station, refer to the respective columns under "Availability" in the table as explained below.

- When a standby master station is operating as a master station: "Master station" column
- When a standby master station is operating as a standby master station: "Local station" column

For the correspondence with the buffer memory, refer to  Page 402, Appendix 2 (5).

### Point

Do not turn ON/OFF the area of the No. which does not exist in the link special relay (SB) list.  
Turning ON/OFF the area of the No. which does not exist in the list may cause malfunction of the programmable controller system.

The following table lists the link special relays.

Number	Name	Description	Availability (○: Available, ×: Not available)		
			Online		Offline
			Master station	Local station	
SB0000 (5E0 <sub>H</sub> , b0)	Data link restart	Restarts the data link that had been stopped by SB0002. OFF: Restart not instructed ON: Restart instructed	○	○	×
SB0001 (5E0 <sub>H</sub> , b1)	Refresh instruction at standby master switching	Instructs to perform cyclic data refresh after the data link control is transferred to the standby master station. OFF: Not instructed ON: Instructed	○	×	×
SB0002 (5E0 <sub>H</sub> , b2)	Data link stop	Stops the host data link. However, when the master station executes this, the entire system will stop. OFF: No stop instruction ON: Stop instructed	○	○	×
SB0003 (5E0 <sub>H</sub> , b3)	Refresh instruction when changing parameters by the dedicated instruction	Instructs to refresh cyclic data after changing parameters by the G(P).RLPASET instruction. OFF: Not instructed (stop refreshing) ON: Instructed (start/continue refreshing)	○	×	×
SB0004 (5E0 <sub>H</sub> , b4)	Temporary error invalid request	Establishes the stations specified by SW0003 to SW0007 as temporary error invalid stations. OFF: Not requested ON: Requested	○	×	×
SB0005 (5E0 <sub>H</sub> , b5)	Temporary error invalid canceling request	Cancels the temporary error invalid status of stations specified by SW0003 to SW0007. OFF: Not requested ON: Requested	○	×	×
SB0007 (5E0 <sub>H</sub> , b7)	Master station duplication error canceling request	Instructs to cancel master station duplication error. OFF: Not instructed ON: Instructed	○*4	×	×
SB0008 (5E0 <sub>H</sub> , b8)	Loop test request	Executes loop tests for the stations specified by SW0008. OFF: Not requested ON: Requested	○	×	×



Number	Name	Description	Availability (○: Available, ×: Not available)		
			Online		Offline
			Master station	Local station	
SB000B (5E0 <sub>H</sub> , b11)	Transmission speed test request	Use this to perform the transmission speed test. OFF: Not requested ON: Requested	○	×	×
SB000C (5E0 <sub>H</sub> , b12)	Forced master switching	Forcefully transfers the data link control from the standby master station that is controlling the data link to the standby master station in case the standby master station becomes faulty. OFF: Not requested ON: Requested	○*1	×	×
SB000D (5E0 <sub>H</sub> , b13)	Remote device station initialization procedure registration instruction	Starts the initial processing using the information registered during the initialization procedure registration. While SB000D is on, the refresh of the remote input/output and remote registers stops. OFF: Not instructed ON: Instructed	○*3	×	×
SB0020 (5E2 <sub>H</sub> , b0)	Module status	Stores the status of communication between the L series master/local module and CPU module. OFF: Normal ON: Abnormal	○	○	○
SB0040 (5E4 <sub>H</sub> , b0)	Data link restart acceptance	Indicates the data link restart instruction acknowledgement status. OFF: Not acknowledged ON: Startup instruction acknowledged	○	○	×
SB0041 (5E4 <sub>H</sub> , b1)	Data link restart complete	Indicates the data link restart instruction acknowledgement completion status. OFF: Not complete ON: Startup complete	○	○	×
SB0042 (5E4 <sub>H</sub> , b2)	Refresh instruction acknowledgement status at standby master switching	Indicates whether or not the refresh instruction at standby master switching have been acknowledged. OFF: Not executed ON: Instruction acknowledged	○	×	×
SB0043 (5E4 <sub>H</sub> , b3)	Refresh instruction complete status at standby master switching	Indicates whether or not the refresh instruction at standby master switching is complete. OFF: Not executed ON: Switching complete	○	×	×
SB0044 (5E4 <sub>H</sub> , b4)	Data link stop acceptance	Indicates the data link stop instruction acknowledgement status. OFF: Not acknowledged ON: Stop instruction acknowledged	○	○	×
SB0045 (5E4 <sub>H</sub> , b5)	Data link stop complete	Indicates the data link stop instruction acknowledgement completion status. OFF: Not complete ON: Stop complete	○	○	×
SB0046 (5E4 <sub>H</sub> , b6)	Forced master switching executable status	Indicates whether the forced master switching (SB000C) signal can be executed or not. OFF: Cannot be executed. ON: Can be executed.	○*1	×	×
SB0048 (5E4 <sub>H</sub> , b8)	Temporary error invalid acceptance status	Indicates the acknowledgement status of temporary error invalid cancel instruction. OFF: Not executed ON: Instruction acknowledged	○	×	×
SB0049 (5E4 <sub>H</sub> , b9)	Temporary error invalid complete status	Indicates the acknowledgement status of temporary error invalid cancel instruction. OFF: Not executed ON: Temporary error invalid station established/Specified station number is invalid	○	×	×
SB004A (5E4 <sub>H</sub> , b10)	Temporary error invalid canceling acknowledgement status	Indicates the acknowledgement status of temporary error invalid cancel instruction. OFF: Not executed ON: Instruction acknowledged	○	×	×

Number	Name	Description	Availability (○: Available, ×: Not available)		
			Online		Offline
			Master station	Local station	
SB004B (5E4 <sub>H</sub> , b11)	Temporary error invalid canceling complete status	Indicates the acknowledgement status of temporary error invalid cancel instruction. OFF: Not executed ON: Temporary error invalid station cancellation complete	○	×	×
SB004C (5E4 <sub>H</sub> , b12)	Loop test acceptance status	Indicates the loop test request acknowledgement status. OFF: Not executed ON: Instruction acknowledged	○	×	×
SB004D (5E4 <sub>H</sub> , b13)	Loop test complete status	Indicates the loop test completion status. OFF: Not executed ON: Test complete	○	×	×
SB0050 (5E5 <sub>H</sub> , b0)	Offline test status	Indicates the offline test execution status. OFF: Not executed ON: In progress	×	×	○
SB0057 (5E5 <sub>H</sub> , b7)	Master station duplication error canceling acknowledgement	Indicates the acknowledgement status of master station duplication error canceling request. OFF: Not acknowledged ON: Acknowledged	○	×	×
SB0058 (5E5 <sub>H</sub> , b8)	Master station duplication error canceling complete	Indicates the completion status of master station duplication error canceling request. OFF: Not complete ON: Complete	○	×	×
SB005A (5E5 <sub>H</sub> , b10)	Master switching request acknowledgement	Indicates whether the standby master station received a master switching request when the standby master station detected that the master station is down. OFF: Not acknowledged ON: Request acknowledged	×	○ <sup>*1</sup>	×
SB005B (5E5 <sub>H</sub> , b11)	Master switching request complete	Indicates whether or not the switching from the standby master station to master station is complete. OFF: Not complete ON: Complete	×	○ <sup>*1</sup>	×
SB005C (5E5 <sub>H</sub> , b12)	Forced master switching request acknowledgement	Indicates whether or not a forced master switching request has been acknowledged. OFF: Not acknowledged ON: Instruction acknowledged	○ <sup>*1</sup>	×	×
SB005D (5E5 <sub>H</sub> , b13)	Forced master switching request complete	Indicates whether or not a forced master switching request is complete. OFF: Not complete ON: Complete	○ <sup>*1</sup>	○ <sup>*1</sup>	×
SB005E (5E5 <sub>H</sub> , b14)	Execution status of remote device station initialization procedure	Indicates the execution status of the initialization procedure. OFF: Not executed ON: Being executed	○ <sup>*3</sup>	×	×
SB005F (5E5 <sub>H</sub> , b15)	Completion status of remote device station initialization procedure	Indicates the completion status of the initialization procedure execution. OFF: Not complete ON: Complete	○ <sup>*3</sup>	×	×
SB0060 (5E6 <sub>H</sub> , b0)	Host mode	Indicates the mode setting status of the host. OFF: Online ON: Other than online	○	○	○
SB0061 (5E6 <sub>H</sub> , b1)	Host type	The station type of the host station is stored. OFF: Master station (station number 0) ON: Local station (station numbers 1 to 64)	○	○	×
SB0062 (5E6 <sub>H</sub> , b2)	Host standby master station setting status	Indicates whether or not the standby master station setting exists for the host. OFF: No setting ON: Setting exists	○	○	○

Number	Name	Description	Availability (○: Available, ×: Not available)				
			Online		Offline		
			Master station	Local station			
SB0065 (5E6 <sub>H</sub> , b5)	Input data status of host data link faulty station	Indicates the status of the data link faulty station setting configured for the host station. OFF: Clear ON: Retain	○	○	×		
SB0066 (5E6 <sub>H</sub> , b6)	Number of host occupied stations	Indicates the setting status of host occupied stations.	×	○	×		
		Number of occupied station				SB0066	SB0067
		1 station				OFF	OFF
SB0067 (5E6 <sub>H</sub> , b7)		2 stations				OFF	ON
		3 stations				ON	ON
	4 stations	ON	OFF				
SB006A (5E6 <sub>H</sub> , b10)	Switch setting status	Indicates the switch setting status. OFF: Normal ON: Setting error exists (the error code is stored in SW006A)	○	○	○		
SB006D (5E6 <sub>H</sub> , b13)	Parameter setting status	Indicates the parameter setting status. OFF: Normal ON: Setting error exists (the error code is stored in SW0068)	○*4	×	×		
SB006E (5E6 <sub>H</sub> , b14)	Host station operation status	Indicates the data link communication status with other stations. OFF: Being executed ON: Not executed	○	○	×		
SB006F (5E6 <sub>H</sub> , b15)	Setting status of block guarantee of cyclic data per station	Indicates the "Block Data Assurance per Station" setting status. OFF: Not set ON: Set	○	○	×		
SB0070 (5E7 <sub>H</sub> , b0)	Master station information	Indicates the data link status. OFF: Data link control by the master station ON: Data link control by the standby master station	○	○	×		
SB0071 (5E7 <sub>H</sub> , b1)	Standby master station information	Indicates whether or not a standby master station is present. OFF: Not present ON: Present	○	○	×		
SB0072 (5E7 <sub>H</sub> , b2)	Scan mode setting information	Indicates the scan mode setting information. OFF: Asynchronous mode ON: Synchronous mode	○	×	×		
SB0073 (5E7 <sub>H</sub> , b3)	Operation specification when CPU is down status	Indicates the operation specification status using a parameter when the CPU is down. OFF: Stop ON: Continue	○	○	×		
SB0074 (5E7 <sub>H</sub> , b4)	Reserved station specified status	Indicates the reserved station specification status using a parameter. OFF: No specification ON: Specification exists (information is stored in SW0074 to SW0077)  Depending on the link refresh timing, SB0074 may be updated with the time difference of one sequence scan from the update of the reserved station specified status (SW0074 to SW0077).	○	○	×		
SB0075 (5E7 <sub>H</sub> , b5)	Error invalid station specified status	Indicates the error invalid station specification status using a parameter. OFF: No specification ON: Specification exists (information is stored in SW0078 to SW007B)  Depending on the link refresh timing, SB0075 may be updated with the time difference of one sequence scan from the update of the error invalid station specified status (SW0078 to SW007B).	○	○	×		

Number	Name	Description	Availability (○: Available, ×: Not available)		
			Online		Offline
			Master station	Local station	
SB0076 (5E7 <sub>H</sub> , b6)	Temporary error invalid station setting information	Indicates whether there is a temporary error invalid station setting. OFF: No setting ON: Setting exists (information is stored in SW007C to SW007F)  Depending on the link refresh timing, SB0076 may be updated with the time difference of one sequence scan from the update of the temporary error invalid status (SW007C to SW007F).	○	○	×
SB0077 (5E7 <sub>H</sub> , b7)	Parameter receive status	Indicates the parameter receive status from the master station. OFF: Reception complete ON: Reception not complete	×	○	×
SB0078 (5E7 <sub>H</sub> , b8)	Host station switch change detection	Detects changes to the host setting switch during data linking. OFF: No changes detected ON: Changes detected	○	○	×
SB0079 (5E7 <sub>H</sub> , b9)	Master station return specification information	Indicates whether the "Type" setting of the network parameters is set to "Master station" or "Master station (Duplex function)." OFF: Master station ON: Master station (Duplex function)	○	×	×
SB007A (5E7 <sub>H</sub> , b10)	Host standby master station operation history	Indicates whether the host station has operated as a standby master station or not. OFF: Not operated as a standby master station ON: Operated as a standby master station	○	×	×
SB007B (5E7 <sub>H</sub> , b11)	Host master/standby master operation status	Indicates whether the host operates as the master or standby master station. OFF: Operates as the master station (controlling data link) ON: Operates as the standby master station (standby)	○	○	×
SB007C (5E7 <sub>H</sub> , b12)	Slave station refresh/compulsory clear setting status in case of programmable controller CPU STOP	Indicates the parameter-set slave station refresh/compulsory clear setting status in case of programmable controller CPU STOP. OFF: Refresh ON: Clears compulsorily	○	×	×
SB007D (5E7 <sub>H</sub> , b13)	Connected devices auto-detection function status	Stores the setting status of the connected devices auto-detection function. OFF: Do not read the model name of the slave stations ON: Read the model name of the slave stations	○	×	×
SB0080 (5E8 <sub>H</sub> , b0)	Other station data link status*2	Indicates the communication status with the slave stations. OFF: All stations normal ON: Faulty station exists (information is stored in SW0080 to SW0083)  Depending on the link refresh timing, SB0080 may be updated with the time difference of one sequence scan from the update of the other station data link status (SW0080 to SW0083).	○	○	×
SB0081 (5E8 <sub>H</sub> , b1)	Other station watchdog timer error status	Indicates the occurrence of a watchdog timer error in other stations. OFF: No error ON: Error occurrence.  Depending on the link refresh timing, SB0081 may be updated with the time difference of one sequence scan from the update of the other station watchdog timer error occurrence status (SW0084 to SW0087).	○	○	×
SB0082 (5E8 <sub>H</sub> , b2)	Other station fuse blown status	Indicates the fuse blown occurrence status at other stations. (SW0088 to SW008B) OFF: No error ON: Error occurrence.  Depending on the link refresh timing, SB0082 may be updated with the time difference of one sequence scan from the update of the other station fuse blown status (SW0088 to SW008B).	○	○	×

Number	Name	Description	Availability (○: Available, ×: Not available)		
			Online		Offline
			Master station	Local station	
SB0083 (5E8 <sub>H</sub> , b3)	Other station switch change status	<p>Detects changes in setting switches of other stations during data linking. OFF: No change ON: Change detected.</p> <p>Depending on the link refresh timing, SB0083 may be updated with the time difference of one sequence scan from the update of the other station switch change status (SW008C to SW008F).</p>	○	○	×
SB0090 (5E9 <sub>H</sub> , b0)	Host line status	<p>Indicates the line status of the host. OFF: Normal ON: Abnormal (line disconnection)</p>	×	○	×
SB0094 (5E9 <sub>H</sub> , b4)	Transient transmission status	<p>Indicates whether a transient transmission error has occurred. OFF: No error ON: Error occurrence. (SW0094 to SW0097) Even when a dedicated instruction was retried, an error is detected.</p> <p>Depending on the link refresh timing, SB0094 may be updated with the time difference of one sequence scan from the update of the transient transmission status (SW0094 to SW0097).</p>	○	○	×
SB0095 (5E9 <sub>H</sub> , b5)	Master station transient transmission status	<p>Indicates the transient transmission status of the master station. OFF: Normal ON: Abnormal</p>	×	○	×
SB00B4 (5EB <sub>H</sub> , b4)	Standby master station test result	<p>Stores the test result of loop test 1. OFF: Normal ON: Abnormal</p>	○	×	○
SB0160 (5F6 <sub>H</sub> , b0)	Remote register use prohibited status	<p>Stores the use prohibited status of the remote register. OFF: Usable ON: Use prohibited (The status information is stored in SW0160 to SW0163.)</p> <p>Depending on the link refresh timing, SB160 may be updated with the time difference of one sequence scan from the update of the remote register use prohibited status (SW0160 to SW0163).</p>	○	×	×
SB0184 (5F8 <sub>H</sub> , b4)	Transmission speed test result for standby master station	<p>Stores a result of the transmission speed test for the standby master station. OFF: Normal (Same transmission speed as that of master station), or no response from the module ON: Abnormal (Different transmission speed from that of master station)</p>	○	×	×
SB0185 (5F8 <sub>H</sub> , b5)	Transmission speed test accept status	<p>Indicates the accept status of Transmission speed test request (SB000B). OFF: Not accepted ON: Accepted</p>	○	×	×
SB0186 (5F8 <sub>H</sub> , b6)	Transmission speed test completion status	<p>Indicates the completion status of the transmission speed test. OFF: Not complete ON: Test complete</p>	○	×	×

\*1 Can be used for the standby master station only.

\*2 The other station data link status (SB0080) takes up to 6 seconds to turn on after a slave station connected to the master/local station becomes faulty.

The time to turn ON differs according to the system configuration, faulty status or other conditions.

\*3 Parameter setting is required in the case of a standby master station.

\*4 For the station No. 0 only.

## Appendix 3.2 Link special registers (SW)

Data is stored in the link special registers SW000 to SW001F by the program, and data is automatically stored in SW0020 to SW01FF.

The values in parentheses in the number column indicate the buffer memory addresses.

When a standby master station is used, refer to the respective columns under "Availability" in the table as explained below.









- When a standby master station is operating as a master station: "Master station" column
- When a standby master station is operating as a standby master station: "Local station" column

### Point

Do not write data to the area of the No. which does not exist in the link special register (SW) list. Writing data to the area of the No. which does not exist in the list may cause malfunction of the programmable controller system.

The following table lists the link special registers.

Number	Name	Description	Availability (○: Available, ×: Not available)																																																				
			Online		Offline																																																		
			Master station	Local station																																																			
SW0003 (603 <sub>H</sub> )	Multiple temporary error invalid station specification	Select whether multiple temporary error invalid stations are specified. 00: Specifies multiple stations indicated by SW0004 to SW0007. 01 to 64: Specifies a single station from 1 to 64. (The specified number indicates the station number of a temporary error invalid station.)	○	×	×																																																		
SW0004 (604 <sub>H</sub> )	Temporary error invalid station specification	Specifies a temporary error invalid station. 0: Not specified as a temporary error invalid station 1: Specified as a temporary error invalid station	○	×	×																																																		
SW0005 (605 <sub>H</sub> )		<table border="1"> <tr> <td></td> <td>b15</td> <td>b14</td> <td>b13</td> <td>b12</td> <td>to</td> <td>b3</td> <td>b2</td> <td>b1</td> <td>b0</td> </tr> <tr> <td>SW0004</td> <td>16</td> <td>15</td> <td>14</td> <td>13</td> <td>to</td> <td>4</td> <td>3</td> <td>2</td> <td>1</td> </tr> <tr> <td>SW0005</td> <td>32</td> <td>31</td> <td>30</td> <td>29</td> <td>to</td> <td>20</td> <td>19</td> <td>18</td> <td>17</td> </tr> <tr> <td>SW0006</td> <td>48</td> <td>47</td> <td>46</td> <td>45</td> <td>to</td> <td>36</td> <td>35</td> <td>34</td> <td>33</td> </tr> <tr> <td>SW0007</td> <td>64</td> <td>63</td> <td>62</td> <td>61</td> <td>to</td> <td>52</td> <td>51</td> <td>50</td> <td>49</td> </tr> </table>					b15	b14	b13	b12	to	b3	b2	b1	b0	SW0004	16	15	14	13	to	4	3	2	1	SW0005	32	31	30	29	to	20	19	18	17	SW0006	48	47	46	45	to	36	35	34	33	SW0007	64	63	62	61	to	52	51	50	49
		b15				b14	b13	b12	to	b3	b2	b1	b0																																										
SW0004		16				15	14	13	to	4	3	2	1																																										
SW0005		32				31	30	29	to	20	19	18	17																																										
SW0006	48	47	46	45	to	36	35	34	33																																														
SW0007	64	63	62	61	to	52	51	50	49																																														
SW0006 (606 <sub>H</sub> )																																																							
SW0007 (607 <sub>H</sub> )		Numbers 1 to 64 in the above table indicate the station numbers.																																																					
		The stations need not be set by the number of occupied stations. Error invalid stations, reserved stations and any station of the number higher than the max. are not specified.																																																					
SW0008 (608 <sub>H</sub> )	Loop test station setting	Set a station number where the loop test is executed. 0: Entire system (executed for all stations) 01 to 64: Specified station only Default value: 0	○	×	×																																																		
SW0009 (609 <sub>H</sub> )	Monitoring time setting	Sets monitoring time when dedicated instructions are used. Default: 10 (seconds) (value = 0) Setting range: 1 to 360 (seconds) If a value outside the range is set, the monitoring time will be 360 seconds. When SW000B is set, the time until a dedicated instruction fails is as follows: (Number of retries + 1) × Monitoring time	○	○	×																																																		
SW000A (60A <sub>H</sub> )	CPU monitoring time setting	Sets the monitoring time of CPU response when the CPU module is accessed through transient transmission. Default: 90 (seconds) (value = 0) Setting range: 1 to 3600 (seconds) If a value outside the range is set, the monitoring time will be 3600 seconds.	○	○	×																																																		

Number	Name	Description	Availability (○: Available, ×: Not available)																																																																																						
			Online		Offline																																																																																				
			Master station	Local station																																																																																					
SW000B (60B <sub>H</sub> )	Dedicated instruction retry count setting	Set the number of retries for use of dedicated instructions. Default value: 0 (No retry) Setting range: 0 to 7 (times) When the set value is out of the range, 7 is applied.	○	○	×																																																																																				
SW0014 (614 <sub>H</sub> )	Specification of remote device station to be initialized.	Specifies the station to be initialized using the information saved in initialization procedure registration. 0: Initial processing not performed 1: Initial processing performed	○	×	×																																																																																				
SW0015 (615 <sub>H</sub> )		<table border="1"> <tr> <td></td> <td>b15</td> <td>b14</td> <td>b13</td> <td>b12</td> <td>b11</td> <td>b10</td> <td>b9</td> <td>b8</td> <td>b7</td> <td>b6</td> <td>b5</td> <td>b4</td> <td>b3</td> <td>b2</td> <td>b1</td> </tr> <tr> <td>SW0014</td> <td>16</td> <td>15</td> <td>14</td> <td>13</td> <td>12</td> <td>11</td> <td>10</td> <td>9</td> <td>8</td> <td>7</td> <td>6</td> <td>5</td> <td>4</td> <td>3</td> <td>2</td> <td>1</td> </tr> <tr> <td>SW0015</td> <td>32</td> <td>31</td> <td>30</td> <td>29</td> <td>28</td> <td>27</td> <td>26</td> <td>25</td> <td>24</td> <td>23</td> <td>22</td> <td>21</td> <td>20</td> <td>19</td> <td>18</td> <td>17</td> </tr> <tr> <td>SW0016</td> <td>48</td> <td>47</td> <td>46</td> <td>45</td> <td>44</td> <td>43</td> <td>42</td> <td>41</td> <td>40</td> <td>39</td> <td>38</td> <td>37</td> <td>36</td> <td>35</td> <td>34</td> <td>33</td> </tr> <tr> <td>SW0017</td> <td>64</td> <td>63</td> <td>62</td> <td>61</td> <td>60</td> <td>59</td> <td>58</td> <td>57</td> <td>56</td> <td>55</td> <td>54</td> <td>53</td> <td>52</td> <td>51</td> <td>50</td> <td>49</td> </tr> </table>					b15	b14	b13	b12	b11	b10	b9	b8	b7	b6	b5	b4	b3	b2	b1	SW0014	16	15	14	13	12	11	10	9	8	7	6	5	4	3	2	1	SW0015	32	31	30	29	28	27	26	25	24	23	22	21	20	19	18	17	SW0016	48	47	46	45	44	43	42	41	40	39	38	37	36	35	34	33	SW0017	64	63	62	61	60	59	58	57	56	55	54	53	52	51	50	49
						b15	b14	b13	b12	b11	b10	b9	b8	b7	b6	b5	b4	b3	b2	b1																																																																					
SW0014						16	15	14	13	12	11	10	9	8	7	6	5	4	3	2	1																																																																				
SW0015						32	31	30	29	28	27	26	25	24	23	22	21	20	19	18	17																																																																				
SW0016	48	47	46	45	44	43	42	41	40	39	38	37	36	35	34	33																																																																									
SW0017	64	63	62	61	60	59	58	57	56	55	54	53	52	51	50	49																																																																									
SW0016 (616 <sub>H</sub> )																																																																																									
SW0017 (617 <sub>H</sub> )	Numbers 1 to 64 in the above table indicate the station numbers. The stations need not be set by the number of occupied stations. Error invalid stations, reserved stations and any station of the number higher than the max. are not specified.																																																																																								
SW0020 (620 <sub>H</sub> )	Module status	Stores the status of communication between the L series master/local module and CPU module. 0: Normal Other than 0: Stores an error code (Refer to the user's manual for the CPU module used.)	○	○	○																																																																																				
SW0041 (641 <sub>H</sub> )	Data link restart result	Stores the execution result of the data link restart instruction with SB0000. 0: Normal Other than 0: Stores an error code (refer to  Page 358, Section 15.3).	○	○	×																																																																																				
SW0043 (643 <sub>H</sub> )	Refresh instruction at standby master switching result	Indicates the execution result of refresh instruction at standby master switching. 0: Normal Other than 0: Stores an error code (refer to  Page 358, Section 15.3).	○	×	×																																																																																				
SW0045 (645 <sub>H</sub> )	Data link stop result	Stores the execution result of the data-link stop instruction with SB0002. 0: Normal Other than 0: Stores an error code (refer to  Page 358, Section 15.3).	○	○	×																																																																																				
SW0049 (649 <sub>H</sub> )	Temporary error invalid station specification result	Indicates the execution result of temporary error invalid station specification. 0: Normal Other than 0: Stores an error code (refer to  Page 358, Section 15.3).	○	×	×																																																																																				
SW004B (64B <sub>H</sub> )	Temporary error invalid station specification cancel result	Indicates the execution result of the temporary error invalid station specification cancellation. 0: Normal Other than 0: Stores an error code (refer to  Page 358, Section 15.3).	○	×	×																																																																																				
SW004D (64D <sub>H</sub> )	Loop test result	Indicates the execution result of the loop test. 0: Normal Other than 0: Stores an error code (refer to  Page 358, Section 15.3).	○	×	×																																																																																				
SW0052 (652 <sub>H</sub> )	Automatic CC-Link startup execution result	Stores the system configuration check result when a new station is added to a system using an automatic CC-Link startup. 0: Normal Other than 0: Stores an error code (refer to  Page 358, Section 15.3)	○	×	×																																																																																				
SW0057 (657 <sub>H</sub> )	Master station duplication error canceling result	Stores the execution result of the master station duplication error canceling request. 0: Normal Other than 0: Stores an error code (refer to  Page 358, Section 15.3)	○	×	×																																																																																				

Appendix 3 Link Special Relays and Registers (SB/SW)  
Appendix 3.2 Link special registers (SW)

Number	Name	Description	Availability (○: Available, ×: Not available)		
			Online		Offline
			Master station	Local station	
SW0058 (658H)	Detailed LED display status	<p>Stores the details of the LED display status. 0: OFF 1: ON</p> <p> b15 b14 b13 b12 b11 b10 b9 b8 b7 b6 b5 b4 b3 b2 b1 b0  0 0 0 0 0 0 0 0 0 0 0 0 0 0 0 0 </p> <ul style="list-style-type: none"> <li>→ LINE(ERR.) : Cable is disconnected or the transmission path is affected by noise.</li> <li>→ TIME(ERR.) : Responses cannot be received from any station due to the cable being disconnected or the transmission path being affected by noise.</li> <li>→ PRM(ERR.) : Invalid parameter value</li> <li>→ M/S(ERR.) : Duplicate master station on the same line</li> <li>→ SW(ERR.) : Error in switch settings</li> <li>→ LOCAL : Operating as a local station</li> <li>→ S MST : Operating as the standby master station</li> <li>→ MST : Operating as the master station</li> <li>→ ERR. : Error occurrence</li> <li>→ RUN : The module is operating normally.</li> </ul>	○	○	○
SW0059 (659H)	Transmission speed setting	<p>Stores the transmission speed setting status. 0: Cancel 1: Set</p> <p> b15 b14 b8 b7 b6 b5 b4 b3 b2 b1 b0  0 to 0 0 0 0 0 0 0 0 0 0 </p> <ul style="list-style-type: none"> <li>→ 10Mbps</li> <li>→ 5Mbps</li> <li>→ 2.5Mbps</li> <li>→ 625kbps</li> <li>→ 156kbps</li> <li>→ Auto-tracking</li> </ul> <p>Auto-tracking is available only for the local station and standby master station.</p>	○	○	○
SW005B (65BH)	Transmission speed operation status	<p>Stores the transmission speed operation status. 0: Not in operation 1: In operation</p> <p> b15 b14 b8 b7 b6 b5 b4 b3 b2 b1 b0  0 to 0 0 0 0 0 0 0 0 0 0 </p> <ul style="list-style-type: none"> <li>→ 10Mbps</li> <li>→ 5Mbps</li> <li>→ 2.5Mbps</li> <li>→ 625kbps</li> <li>→ 156kbps</li> <li>→ During auto-tracking</li> </ul> <p>Auto-tracking is available only for the local station and standby master station.</p>	○	○	○





Number	Name	Description	Availability (○: Available, ×: Not available)		
			Online		Offline
			Master station	Local station	
SW005C (65C <sub>H</sub> )	Detailed LED display status (2)	Stores the detailed display status of the module LED. 0: OFF 1: ON  	○	○	○
SW005D (65D <sub>H</sub> )	Forced master switching instruction result	Stores the execution result of the forced master switching instruction with SB000C. 0: Normal Other than 0: Stores an error code (refer to  Page 358, Section 15.3).	○*1	×	×
SW005F (65F <sub>H</sub> )	Remote device station initialization procedure registration instruction result	Stores the execution result of the initialization procedure registration instruction with SB000D. 0: Normal Other than 0: Stores an error code (refer to  Page 358, Section 15.3).	○*7	×	×
SW0060 (660 <sub>H</sub> )	Mode setting status	Stores the mode setting status. 0: Online (Remote net mode) 1: Online (Remote I/O net mode) 2: Offline 3: Loop test 1 4: Loop test 2 6: Hardware test	○	○	○
SW0061 (661 <sub>H</sub> )	Host station number	Stores the station number of the host that is currently in operation. 0: Master station 1 to 64: Local station	○	○	○

Appendix 3 Link Special Relays and Registers (SB/SW)  
Appendix 3.2 Link special registers (SW)

Number	Name	Description	Availability (○: Available, ×: Not available)		
			Online		Offline
			Master station	Local station	
SW0062 (662 <sub>H</sub> )	Module operating status	<p>Stores the operation setting status of the module.</p> <p>           b15 b14 b13 b12 b11 b10 b9 b8 b7 b6 b5 b4 b3 b2 b1 b0            0 0 0 0 0 0 0 0 0 0 0 0 0 0 0 0         </p> <ul style="list-style-type: none"> <li>→ Station type 0: Master station/local station 1: Standby master station (Valid only when b1 is 0)</li> <li>→ Master station duplex function 0: Master station duplex function disabled 1: Master station duplex function enabled</li> <li>→ Status of input data from a data link faulty station 0: Clear 1: Hold</li> <li>→ Number of occupied stations 00: Number of occupied stations: 1 10: Number of occupied stations: 2 11: Number of occupied stations: 3 01: Number of occupied stations: 4</li> <li>→ Master station/local station start by dedicated instruction 0: Start by CPU parameter 1: Start by dedicated instruction</li> <li>→ Slave station refresh/compulsory clear setting in case of programmable controller CPU STOP 0: Refresh 1: Clears compulsorily</li> <li>→ Expanded cyclic setting 00: Single 01: Double 10: Quadruple 11: Octuple</li> <li>→ Block guarantee of cyclic data per station 0: Not set 1: Set</li> <li>→ Connected devices auto-detection setting 0: Not read the model name of the slave stations 1: Read the model name of the slave stations</li> </ul>	○	○	○
SW0064 (664 <sub>H</sub> )	No. of retries information	Indicates the retry count setting information when there is an error response. 1 to 7 (times)	○	×	×
SW0065 (665 <sub>H</sub> )	No. of automatic return stations	Indicates the setting information for the number of automatic return stations during one link scan. 1 to 10 (stations)	○	×	×
SW0066 (666 <sub>H</sub> )	Delay timer information	Indicates the delay time setting information.	○	×	×
SW0067 (667 <sub>H</sub> )	Parameter information	Stores the parameter information area to be used. 0 <sub>H</sub> : CPU built-in parameters 3 <sub>H</sub> : Dedicated instruction (parameter setting with the G(P).RLPASET instruction and data link startup.) D <sub>H</sub> : Default parameters (automatically starts CC-Link)	○	×	○
SW0068 (668 <sub>H</sub> )	Host parameter status	Stores the parameter setting status. 0: Normal Other than 0: Stores an error code (refer to  Page 358, Section 15.3).	○	○	×
SW0069 (669 <sub>H</sub> )	Loading status <sup>*3</sup>	Stores the duplicate station number status and parameter matching of each station. 0: Normal Other than 0: Stores the error code (refer to  Page 358, Section 15.3). Details are stored in SW0098 to SW009B and SW009C to SW009F.	○	×	×
SW006A (66A <sub>H</sub> )	Switch setting status	Stores the switch setting status. 0: Normal Other than 0: Stores an error code (refer to  Page 358, Section 15.3).	○	○	○
SW006D (66D <sub>H</sub> )	Max. link scan time	Stores the maximum value of the link scan time (in 1 ms units).	○	○	×
SW006E (66E <sub>H</sub> )	Current link scan time	Stores the current value of the link scan time (in 1 ms units).	○	○	×
SW006F (66F <sub>H</sub> )	Min. link scan time	Stores the minimum value of the link scan time (in 1 ms units).	○	○	×



Number	Name	Description	Availability (○: Available, ×: Not available)																																																				
			Online		Offline																																																		
			Master station	Local station																																																			
SW0070 (670 <sub>H</sub> )	Total number of stations	Stores the final station number set in the parameter. 1 to 64 (stations)	○	×	×																																																		
SW0071 (671 <sub>H</sub> )	Max. communication station number	Stores the maximum station number (set number of the station number setting) that is performing data link. 1 to 64 (stations) Reserved stations are excepted.	○	×	×																																																		
SW0072 (672 <sub>H</sub> )	Number of connected modules	Stores the number of modules that are performing data link. Reserved stations are excepted.	○	×	×																																																		
SW0073 (673 <sub>H</sub> )	Standby master station number	Stores the station number of the standby master station. 1 to 64 (stations)	○	○	×																																																		
SW0074 (674 <sub>H</sub> )	Reserved station specified status*2	Stores the reserved station setting status. 0: Not reserved station 1: Reserved station	○	○	×																																																		
SW0075 (675 <sub>H</sub> )		<table border="1"> <thead> <tr> <th></th> <th>b15</th> <th>b14</th> <th>b13</th> <th>b12</th> <th>to</th> <th>b3</th> <th>b2</th> <th>b1</th> <th>b0</th> </tr> </thead> <tbody> <tr> <td>SW0074</td> <td>16</td> <td>15</td> <td>14</td> <td>13</td> <td>to</td> <td>4</td> <td>3</td> <td>2</td> <td>1</td> </tr> <tr> <td>SW0075</td> <td>32</td> <td>31</td> <td>30</td> <td>29</td> <td>to</td> <td>20</td> <td>19</td> <td>18</td> <td>17</td> </tr> <tr> <td>SW0076</td> <td>48</td> <td>47</td> <td>46</td> <td>45</td> <td>to</td> <td>36</td> <td>35</td> <td>34</td> <td>33</td> </tr> <tr> <td>SW0077</td> <td>64</td> <td>63</td> <td>62</td> <td>61</td> <td>to</td> <td>52</td> <td>51</td> <td>50</td> <td>49</td> </tr> </tbody> </table>					b15	b14	b13	b12	to	b3	b2	b1	b0	SW0074	16	15	14	13	to	4	3	2	1	SW0075	32	31	30	29	to	20	19	18	17	SW0076	48	47	46	45	to	36	35	34	33	SW0077	64	63	62	61	to	52	51	50	49
		b15				b14	b13	b12	to	b3	b2	b1	b0																																										
SW0074		16				15	14	13	to	4	3	2	1																																										
SW0075		32				31	30	29	to	20	19	18	17																																										
SW0076	48	47	46	45	to	36	35	34	33																																														
SW0077	64	63	62	61	to	52	51	50	49																																														
SW0076 (676 <sub>H</sub> )																																																							
SW0077 (677 <sub>H</sub> )																																																							
		Numbers 1 to 64 in the above table indicate the station numbers. Any station of the number higher than the max. are excepted.																																																					
SW0078 (678 <sub>H</sub> )	Error invalid station specified status*2	Stores the error invalid station setting status. 0: Other than error invalid station 1: Error invalid station	○	○	×																																																		
SW0079 (679 <sub>H</sub> )		<table border="1"> <thead> <tr> <th></th> <th>b15</th> <th>b14</th> <th>b13</th> <th>b12</th> <th>to</th> <th>b3</th> <th>b2</th> <th>b1</th> <th>b0</th> </tr> </thead> <tbody> <tr> <td>SW0078</td> <td>16</td> <td>15</td> <td>14</td> <td>13</td> <td>to</td> <td>4</td> <td>3</td> <td>2</td> <td>1</td> </tr> <tr> <td>SW0079</td> <td>32</td> <td>31</td> <td>30</td> <td>29</td> <td>to</td> <td>20</td> <td>19</td> <td>18</td> <td>17</td> </tr> <tr> <td>SW007A</td> <td>48</td> <td>47</td> <td>46</td> <td>45</td> <td>to</td> <td>36</td> <td>35</td> <td>34</td> <td>33</td> </tr> <tr> <td>SW007B</td> <td>64</td> <td>63</td> <td>62</td> <td>61</td> <td>to</td> <td>52</td> <td>51</td> <td>50</td> <td>49</td> </tr> </tbody> </table>					b15	b14	b13	b12	to	b3	b2	b1	b0	SW0078	16	15	14	13	to	4	3	2	1	SW0079	32	31	30	29	to	20	19	18	17	SW007A	48	47	46	45	to	36	35	34	33	SW007B	64	63	62	61	to	52	51	50	49
		b15				b14	b13	b12	to	b3	b2	b1	b0																																										
SW0078		16				15	14	13	to	4	3	2	1																																										
SW0079		32				31	30	29	to	20	19	18	17																																										
SW007A	48	47	46	45	to	36	35	34	33																																														
SW007B	64	63	62	61	to	52	51	50	49																																														
SW007A (67A <sub>H</sub> )																																																							
SW007B (67B <sub>H</sub> )																																																							
		Numbers 1 to 64 in the above table indicate the station numbers. Reserved stations and any station of the number higher than the max. are excepted.																																																					
SW007C (67C <sub>H</sub> )	Temporary error invalid status*4	Indicates the temporary error invalid status. 0: Normal status 1: Temporary error invalid status	○	○	×																																																		
SW007D (67D <sub>H</sub> )		<table border="1"> <thead> <tr> <th></th> <th>b15</th> <th>b14</th> <th>b13</th> <th>b12</th> <th>to</th> <th>b3</th> <th>b2</th> <th>b1</th> <th>b0</th> </tr> </thead> <tbody> <tr> <td>SW007C</td> <td>16</td> <td>15</td> <td>14</td> <td>13</td> <td>to</td> <td>4</td> <td>3</td> <td>2</td> <td>1</td> </tr> <tr> <td>SW007D</td> <td>32</td> <td>31</td> <td>30</td> <td>29</td> <td>to</td> <td>20</td> <td>19</td> <td>18</td> <td>17</td> </tr> <tr> <td>SW007E</td> <td>48</td> <td>47</td> <td>46</td> <td>45</td> <td>to</td> <td>36</td> <td>35</td> <td>34</td> <td>33</td> </tr> <tr> <td>SW007F</td> <td>64</td> <td>63</td> <td>62</td> <td>61</td> <td>to</td> <td>52</td> <td>51</td> <td>50</td> <td>49</td> </tr> </tbody> </table>					b15	b14	b13	b12	to	b3	b2	b1	b0	SW007C	16	15	14	13	to	4	3	2	1	SW007D	32	31	30	29	to	20	19	18	17	SW007E	48	47	46	45	to	36	35	34	33	SW007F	64	63	62	61	to	52	51	50	49
		b15				b14	b13	b12	to	b3	b2	b1	b0																																										
SW007C		16				15	14	13	to	4	3	2	1																																										
SW007D		32				31	30	29	to	20	19	18	17																																										
SW007E	48	47	46	45	to	36	35	34	33																																														
SW007F	64	63	62	61	to	52	51	50	49																																														
SW007E (67E <sub>H</sub> )																																																							
SW007F (67F <sub>H</sub> )																																																							
		Numbers 1 to 64 in the above table indicate the station numbers. Error invalid stations, reserved stations and any station of the number higher than the max. are excepted.																																																					

Appendix 3 Link Special Relays and Registers (SB/SW)  
Appendix 3.2 Link special registers (SW)

Number	Name	Description	Availability (○: Available, ×: Not available)		
			Online		Offline
			Master station	Local station	
SW0080 (680 <sub>H</sub> )	Other station data link status <sup>*4*6</sup>	Stores the data link status of each station. 0: Normal 1: Data link error occurred	○	○	×
SW0081 (681 <sub>H</sub> )					
SW0082 (682 <sub>H</sub> )					
SW0083 (683 <sub>H</sub> )					
SW0084 (684 <sub>H</sub> )	Other station watchdog timer error occurrence status <sup>*2</sup>	Indicates the watchdog timer error occurrence status. 0: No watchdog timer error 1: Watchdog timer error occurred	○	○	×
SW0085 (685 <sub>H</sub> )					
SW0086 (686 <sub>H</sub> )					
SW0087 (687 <sub>H</sub> )					
SW0088 (688 <sub>H</sub> )	Other station fuse blown status <sup>*4</sup>	Stores the fuse blown occurrence status of each station. 0: Normal 1: Fuse blown	○	×	×
SW0089 (689 <sub>H</sub> )					
SW008A (68A <sub>H</sub> )					
SW008B (68B <sub>H</sub> )					
SW008C (68C <sub>H</sub> )	Other station switch change status <sup>*2</sup>	Indicates the switch change status of other stations performing data link. 0: No change 1: Change occurred	○	○	×
SW008D (68D <sub>H</sub> )					
SW008E (68E <sub>H</sub> )					
SW008F (68F <sub>H</sub> )					
SW0090 (690 <sub>H</sub> )	Line status	Stores the line status. 0: Normal 1: Data link cannot be performed (disconnected)	×	○	×



Number	Name	Description	Availability (○: Available, ×: Not available)																																																											
			Online		Offline																																																									
			Master station	Local station																																																										
SW0094 (694 <sub>H</sub> )  SW0095 (695 <sub>H</sub> )  SW0096 (696 <sub>H</sub> )  SW0097 (697 <sub>H</sub> )	Transient transmission status* <sup>2</sup>	<p>Indicates the transient transmission error status.</p> <p>0: No transient transmission error 1: Transient transmission error occurrence</p> <table border="1"> <thead> <tr> <th></th> <th>b15</th> <th>b14</th> <th>b13</th> <th>b12</th> <th>to</th> <th>b3</th> <th>b2</th> <th>b1</th> <th>b0</th> </tr> </thead> <tbody> <tr> <td>SW0094</td> <td>16</td> <td>15</td> <td>14</td> <td>13</td> <td>to</td> <td>4</td> <td>3</td> <td>2</td> <td>1</td> </tr> <tr> <td>SW0095</td> <td>32</td> <td>31</td> <td>30</td> <td>29</td> <td>to</td> <td>20</td> <td>19</td> <td>18</td> <td>17</td> </tr> <tr> <td>SW0096</td> <td>48</td> <td>47</td> <td>46</td> <td>45</td> <td>to</td> <td>36</td> <td>35</td> <td>34</td> <td>33</td> </tr> <tr> <td>SW0097</td> <td>64</td> <td>63</td> <td>62</td> <td>61</td> <td>to</td> <td>52</td> <td>51</td> <td>50</td> <td>49</td> </tr> </tbody> </table> <p>Numbers 1 to 64 in the above table indicate the station numbers. Reserved stations and any station of the number higher than the max. are excluded. Even when a dedicated instruction was retried, an error is detected.</p>		b15	b14	b13	b12	to	b3	b2	b1	b0	SW0094	16	15	14	13	to	4	3	2	1	SW0095	32	31	30	29	to	20	19	18	17	SW0096	48	47	46	45	to	36	35	34	33	SW0097	64	63	62	61	to	52	51	50	49	○	○	×							
		b15	b14	b13	b12	to	b3	b2	b1	b0																																																				
SW0094		16	15	14	13	to	4	3	2	1																																																				
SW0095		32	31	30	29	to	20	19	18	17																																																				
SW0096		48	47	46	45	to	36	35	34	33																																																				
SW0097	64	63	62	61	to	52	51	50	49																																																					
SW0098 (698 <sub>H</sub> )  SW0099 (699 <sub>H</sub> )  SW009A (69A <sub>H</sub> )  SW009B (69B <sub>H</sub> )	Station number overlap status* <sup>5</sup>	<p>Stores the overlap status when the first station number of each module is not overlapped.</p> <p>0: Normal 1: Overlap station number (first station number only)</p> <table border="1"> <thead> <tr> <th></th> <th>b15</th> <th>b14</th> <th>b13</th> <th>b12</th> <th>to</th> <th>b3</th> <th>b2</th> <th>b1</th> <th>b0</th> </tr> </thead> <tbody> <tr> <td>SW0098</td> <td>16</td> <td>15</td> <td>14</td> <td>13</td> <td>to</td> <td>4</td> <td>3</td> <td>2</td> <td>1</td> </tr> <tr> <td>SW0099</td> <td>32</td> <td>31</td> <td>30</td> <td>29</td> <td>to</td> <td>20</td> <td>19</td> <td>18</td> <td>17</td> </tr> <tr> <td>SW009A</td> <td>48</td> <td>47</td> <td>46</td> <td>45</td> <td>to</td> <td>36</td> <td>35</td> <td>34</td> <td>33</td> </tr> <tr> <td>SW009B</td> <td>64</td> <td>63</td> <td>62</td> <td>61</td> <td>to</td> <td>52</td> <td>51</td> <td>50</td> <td>49</td> </tr> </tbody> </table> <p>Numbers 1 to 64 in the above table indicate the station numbers. Reserved stations and any station of the number higher than the max. are excluded. Unable to detect station number overlapping of standby master stations. For the slave stations with "Auto-tracking" set for transmission speed, station numbers may not be detected even when any of them are overlapping.</p>		b15	b14	b13	b12	to	b3	b2	b1	b0	SW0098	16	15	14	13	to	4	3	2	1	SW0099	32	31	30	29	to	20	19	18	17	SW009A	48	47	46	45	to	36	35	34	33	SW009B	64	63	62	61	to	52	51	50	49	○	×	×							
		b15	b14	b13	b12	to	b3	b2	b1	b0																																																				
SW0098		16	15	14	13	to	4	3	2	1																																																				
SW0099		32	31	30	29	to	20	19	18	17																																																				
SW009A		48	47	46	45	to	36	35	34	33																																																				
SW009B	64	63	62	61	to	52	51	50	49																																																					
SW009C (69C <sub>H</sub> )  SW009D (69D <sub>H</sub> )  SW009E (69E <sub>H</sub> )  SW009F (69F <sub>H</sub> )	Loading/parameter consistency status* <sup>5</sup>	<p>Stores the consistency status between the loaded station and the parameter settings.</p> <p>A matching error occurs in any of the following cases.</p> <p>1) Station type mismatch * 2) Number of occupied stations mismatch 3) Expanded cyclic setting mismatch * 4) CC-Link compatible version mismatch</p> <p>* A matching error will not occur when installation ≤ parameter. (For example, a matching error will not occur when a remote device station is installed and the parameter setting is an intelligent device station.)</p> <p>0: Normal 1: Matching error</p> <p>Example of matching error</p> <table border="1"> <thead> <tr> <th>Installation</th> <th>Parameter</th> </tr> </thead> <tbody> <tr> <td>Remote device station</td> <td>Remote I/O station</td> </tr> <tr> <td rowspan="2">Intelligent device station</td> <td>Remote I/O station</td> </tr> <tr> <td>Remote device station</td> </tr> </tbody> </table> <table border="1"> <thead> <tr> <th></th> <th>b15</th> <th>b14</th> <th>b13</th> <th>b12</th> <th>to</th> <th>b3</th> <th>b2</th> <th>b1</th> <th>b0</th> </tr> </thead> <tbody> <tr> <td>SW009C</td> <td>16</td> <td>15</td> <td>14</td> <td>13</td> <td>to</td> <td>4</td> <td>3</td> <td>2</td> <td>1</td> </tr> <tr> <td>SW009D</td> <td>32</td> <td>31</td> <td>30</td> <td>29</td> <td>to</td> <td>20</td> <td>19</td> <td>18</td> <td>17</td> </tr> <tr> <td>SW009E</td> <td>48</td> <td>47</td> <td>46</td> <td>45</td> <td>to</td> <td>36</td> <td>35</td> <td>34</td> <td>33</td> </tr> <tr> <td>SW009F</td> <td>64</td> <td>63</td> <td>62</td> <td>61</td> <td>to</td> <td>52</td> <td>51</td> <td>50</td> <td>49</td> </tr> </tbody> </table> <p>Numbers 1 to 64 in the above table indicate the station numbers. Reserved stations and any station of the number higher than the max. are excluded.</p>	Installation	Parameter	Remote device station	Remote I/O station	Intelligent device station	Remote I/O station	Remote device station		b15	b14	b13	b12	to	b3	b2	b1	b0	SW009C	16	15	14	13	to	4	3	2	1	SW009D	32	31	30	29	to	20	19	18	17	SW009E	48	47	46	45	to	36	35	34	33	SW009F	64	63	62	61	to	52	51	50	49	○	×	×
Installation		Parameter																																																												
Remote device station		Remote I/O station																																																												
Intelligent device station		Remote I/O station																																																												
		Remote device station																																																												
	b15	b14	b13	b12	to	b3	b2	b1	b0																																																					
SW009C	16	15	14	13	to	4	3	2	1																																																					
SW009D	32	31	30	29	to	20	19	18	17																																																					
SW009E	48	47	46	45	to	36	35	34	33																																																					
SW009F	64	63	62	61	to	52	51	50	49																																																					

Appendix 3 Link Special Relays and Registers (SB/SW)  
Appendix 3.2 Link special registers (SW)

Number	Name	Description	Availability (○: Available, ×: Not available)																																																				
			Online		Offline																																																		
			Master station	Local station																																																			
SW00B4 (6B4 <sub>H</sub> )	Loop test 1 result*4	Stores the loop test 1 result. 0: Normal 1: Abnormal	○	×	○																																																		
SW00B5 (6B5 <sub>H</sub> )		<table border="1"> <thead> <tr> <th></th> <th>b15</th> <th>b14</th> <th>b13</th> <th>b12</th> <th>to</th> <th>b3</th> <th>b2</th> <th>b1</th> <th>b0</th> </tr> </thead> <tbody> <tr> <td>SW00B4</td> <td>16</td> <td>15</td> <td>14</td> <td>13</td> <td>to</td> <td>4</td> <td>3</td> <td>2</td> <td>1</td> </tr> <tr> <td>SW00B5</td> <td>32</td> <td>31</td> <td>30</td> <td>29</td> <td>to</td> <td>20</td> <td>19</td> <td>18</td> <td>17</td> </tr> <tr> <td>SW00B6</td> <td>48</td> <td>47</td> <td>46</td> <td>45</td> <td>to</td> <td>36</td> <td>35</td> <td>34</td> <td>33</td> </tr> <tr> <td>SW00B7</td> <td>64</td> <td>63</td> <td>62</td> <td>61</td> <td>to</td> <td>52</td> <td>51</td> <td>50</td> <td>49</td> </tr> </tbody> </table>					b15	b14	b13	b12	to	b3	b2	b1	b0	SW00B4	16	15	14	13	to	4	3	2	1	SW00B5	32	31	30	29	to	20	19	18	17	SW00B6	48	47	46	45	to	36	35	34	33	SW00B7	64	63	62	61	to	52	51	50	49
		b15				b14	b13	b12	to	b3	b2	b1	b0																																										
SW00B4		16				15	14	13	to	4	3	2	1																																										
SW00B5	32	31	30	29	to	20	19	18	17																																														
SW00B6	48	47	46	45	to	36	35	34	33																																														
SW00B7	64	63	62	61	to	52	51	50	49																																														
SW00B6 (6B6 <sub>H</sub> )																																																							
SW00B7 (6B7 <sub>H</sub> )		Numbers 1 to 64 in the above table indicate the station numbers.																																																					
SW00B8 (6B8 <sub>H</sub> )	Loop test result	Stores the loop test 1/loop test 2 result. 0: Normal Other than 0: Stores an error code (refer to  Page 358, Section 15.3).	×	×	○																																																		
SW0110 (710 <sub>H</sub> )	Remote device station initialization procedure registration execution individual information (target 1)	Stores the execution information of initialization procedure registration. High: Next execution procedure number (FF <sub>H</sub> at completion) Low: Targeted station number	○*7	×	×																																																		
SW0111 (711 <sub>H</sub> )	Remote device station initialization procedure registration execution individual information (target 2)																																																						
SW0112 (712 <sub>H</sub> )	Remote device station initialization procedure registration execution individual information (target 3)																																																						

Number	Name	Description	Availability (○: Available, ×: Not available)		
			Online		Offline
			Master station	Local station	
SW0113 (713 <sub>H</sub> )	Remote device station initialization procedure registration execution individual information (target 4)	Stores the execution information of initialization procedure registration. High: Next execution procedure number (FF <sub>H</sub> at completion) Low: Targeted station number			
SW0114 (714 <sub>H</sub> )	Remote device station initialization procedure registration execution individual information (target 5)				
SW0115 (715 <sub>H</sub> )	Remote device station initialization procedure registration execution individual information (target 6)		○*7	×	×
SW0116 (716 <sub>H</sub> )	Remote device station initialization procedure registration execution individual information (target 7)				
SW0117 (718 <sub>H</sub> )	Remote device station initialization procedure registration execution individual information (target 8)				
SW0118 (718 <sub>H</sub> )	Remote device station initialization procedure registration execution individual information (target 9)				

Number	Name	Description	Availability (○: Available, ×: Not available)																																																				
			Online		Offline																																																		
			Master station	Local station																																																			
SW0119 (719 <sub>H</sub> )	Remote device station initialization procedure registration execution individual information (target 10)	Stores the execution information of initialization procedure registration. High: Next execution procedure number (FF <sub>H</sub> at completion) Low: Targeted station number	○ <sup>*7</sup>	×	×																																																		
SW011A (71A <sub>H</sub> )	Remote device station initialization procedure registration execution individual information (target 11)																																																						
SW011B (71B <sub>H</sub> )	Remote device station initialization procedure registration execution individual information (target 12)																																																						
SW011C (71C <sub>H</sub> )	Remote device station initialization procedure registration execution individual information (target 13)																																																						
SW011D (71D <sub>H</sub> )	Remote device station initialization procedure registration execution individual information (target 14)																																																						
SW011E (71E <sub>H</sub> )	Remote device station initialization procedure registration execution individual information (target 15)																																																						
SW011F (71F <sub>H</sub> )	Remote device station initialization procedure registration execution individual information (target 16)	Stores the execution information of initialization procedure registration. High: Next execution procedure number (FF <sub>H</sub> at completion) Low: Targeted station number	○ <sup>*7</sup>	×	×																																																		
SW0140 (740 <sub>H</sub> )  SW0141 (741 <sub>H</sub> )  SW0142 (742 <sub>H</sub> )  SW0143 (743 <sub>H</sub> )	Compatible CC-Link ver. information <sup>*4</sup>	Indicates the slave stations compatible with CC-Link ver.2. 0: Ver.1 compatible slave station 1: Ver.2 compatible slave station  <table border="1" style="margin-left: 40px;"> <thead> <tr> <th></th> <th>b15</th> <th>b14</th> <th>b13</th> <th>b12</th> <th>to</th> <th>b3</th> <th>b2</th> <th>b1</th> <th>b0</th> </tr> </thead> <tbody> <tr> <td>SW0140</td> <td>16</td> <td>15</td> <td>14</td> <td>13</td> <td>to</td> <td>4</td> <td>3</td> <td>2</td> <td>1</td> </tr> <tr> <td>SW0141</td> <td>32</td> <td>31</td> <td>30</td> <td>29</td> <td>to</td> <td>20</td> <td>19</td> <td>18</td> <td>17</td> </tr> <tr> <td>SW0142</td> <td>48</td> <td>47</td> <td>46</td> <td>45</td> <td>to</td> <td>36</td> <td>35</td> <td>34</td> <td>33</td> </tr> <tr> <td>SW0143</td> <td>64</td> <td>63</td> <td>62</td> <td>61</td> <td>to</td> <td>52</td> <td>51</td> <td>50</td> <td>49</td> </tr> </tbody> </table> <p style="margin-left: 40px;">Numbers 1 to 64 in the above table indicate the station numbers.</p> Reserved stations and any station of the number higher than the max. are excepted.		b15	b14	b13	b12	to	b3	b2	b1	b0	SW0140	16	15	14	13	to	4	3	2	1	SW0141	32	31	30	29	to	20	19	18	17	SW0142	48	47	46	45	to	36	35	34	33	SW0143	64	63	62	61	to	52	51	50	49	○	×	×
	b15	b14	b13	b12	to	b3	b2	b1	b0																																														
SW0140	16	15	14	13	to	4	3	2	1																																														
SW0141	32	31	30	29	to	20	19	18	17																																														
SW0142	48	47	46	45	to	36	35	34	33																																														
SW0143	64	63	62	61	to	52	51	50	49																																														



Number	Name	Description	Availability (○: Available, ×: Not available)																																																												
			Online		Offline																																																										
			Master station	Local station																																																											
SW0144 (744 <sub>H</sub> ) SW0145 (745 <sub>H</sub> ) SW0146 (746 <sub>H</sub> ) SW0147 (747 <sub>H</sub> )	CC-Link ver. installation/parameter matching status <sup>*4</sup>	<p>Stores the CC-Link version matching status of the parameters and slave stations. 0: Normal 1: Matching error Example of matching error</p> <table border="1"> <thead> <tr> <th colspan="2">Installation</th> <th colspan="2">Parameter</th> </tr> </thead> <tbody> <tr> <td>Ver.2 compatible remote device station</td> <td>Ver.1 compatible remote device station</td> <td>Ver.1 compatible remote device station</td> <td>Ver.2 compatible remote device station</td> </tr> </tbody> </table> <table border="1"> <thead> <tr> <th></th> <th>b15</th> <th>b14</th> <th>b13</th> <th>b12</th> <th>to</th> <th>b3</th> <th>b2</th> <th>b1</th> <th>b0</th> </tr> </thead> <tbody> <tr> <td>SW0144</td> <td>16</td> <td>15</td> <td>14</td> <td>13</td> <td>to</td> <td>4</td> <td>3</td> <td>2</td> <td>1</td> </tr> <tr> <td>SW0145</td> <td>32</td> <td>31</td> <td>30</td> <td>29</td> <td>to</td> <td>20</td> <td>19</td> <td>18</td> <td>17</td> </tr> <tr> <td>SW0146</td> <td>48</td> <td>47</td> <td>46</td> <td>45</td> <td>to</td> <td>36</td> <td>35</td> <td>34</td> <td>33</td> </tr> <tr> <td>SW0147</td> <td>64</td> <td>63</td> <td>62</td> <td>61</td> <td>to</td> <td>52</td> <td>51</td> <td>50</td> <td>49</td> </tr> </tbody> </table> <p>Numbers 1 to 64 in the above table indicate the station numbers. Reserved stations and final station number onwards are not targeted.</p>	Installation		Parameter		Ver.2 compatible remote device station	Ver.1 compatible remote device station	Ver.1 compatible remote device station	Ver.2 compatible remote device station		b15	b14	b13	b12	to	b3	b2	b1	b0	SW0144	16	15	14	13	to	4	3	2	1	SW0145	32	31	30	29	to	20	19	18	17	SW0146	48	47	46	45	to	36	35	34	33	SW0147	64	63	62	61	to	52	51	50	49	○	×	×
Installation		Parameter																																																													
Ver.2 compatible remote device station	Ver.1 compatible remote device station	Ver.1 compatible remote device station	Ver.2 compatible remote device station																																																												
	b15	b14	b13	b12	to	b3	b2	b1	b0																																																						
SW0144	16	15	14	13	to	4	3	2	1																																																						
SW0145	32	31	30	29	to	20	19	18	17																																																						
SW0146	48	47	46	45	to	36	35	34	33																																																						
SW0147	64	63	62	61	to	52	51	50	49																																																						
SW0148 (748 <sub>H</sub> )	Parameter mode	<p>Indicates in which mode the system is operating. 0: Remote net ver.1 mode 1: Remote net additional mode 2: Remote net ver.2 mode</p>	○	○	×																																																										
SW0149 (749 <sub>H</sub> )	Host parameter mode	<p>Indicates in which mode the host is operating. 0: Remote net ver.1 mode 1: Remote net additional mode 2: Remote net ver.2 mode</p>	○	○	○																																																										
SW0152 (752 <sub>H</sub> )	Max. communication station number	<p>Stores the maximum station number (station number of the station number setting) that is performing data link. 1 to 64 (stations) Reserved, error invalid, and temporary error invalid stations are not included.</p>	○	×	×																																																										
SW0153 (753 <sub>H</sub> )	Number of connected modules involved in communication	<p>Stores the number of modules that are performing data link. Reserved, error invalid, and temporary error invalid stations are not included.</p>	○	×	×																																																										
SW0160 (760 <sub>H</sub> ) SW0161 (761 <sub>H</sub> ) SW0162 (762 <sub>H</sub> ) SW0163 (763 <sub>H</sub> )	Remote register use prohibited status <sup>*2</sup>	<p>Stores the use prohibited status of the remote register. OFF: Usable ON: Use prohibited</p> <table border="1"> <thead> <tr> <th></th> <th>b15</th> <th>b14</th> <th>b13</th> <th>b12</th> <th>to</th> <th>b3</th> <th>b2</th> <th>b1</th> <th>b0</th> </tr> </thead> <tbody> <tr> <td>SW0160</td> <td>16</td> <td>15</td> <td>14</td> <td>13</td> <td>to</td> <td>4</td> <td>3</td> <td>2</td> <td>1</td> </tr> <tr> <td>SW0161</td> <td>32</td> <td>31</td> <td>30</td> <td>29</td> <td>to</td> <td>20</td> <td>19</td> <td>18</td> <td>17</td> </tr> <tr> <td>SW0162</td> <td>48</td> <td>47</td> <td>46</td> <td>45</td> <td>to</td> <td>36</td> <td>35</td> <td>34</td> <td>33</td> </tr> <tr> <td>SW0163</td> <td>64</td> <td>63</td> <td>62</td> <td>61</td> <td>to</td> <td>52</td> <td>51</td> <td>50</td> <td>49</td> </tr> </tbody> </table> <p>1 to 64 in the table indicate station numbers. Reserved stations and final station number onwards are not targeted.</p>		b15	b14	b13	b12	to	b3	b2	b1	b0	SW0160	16	15	14	13	to	4	3	2	1	SW0161	32	31	30	29	to	20	19	18	17	SW0162	48	47	46	45	to	36	35	34	33	SW0163	64	63	62	61	to	52	51	50	49	○	×	×								
	b15	b14	b13	b12	to	b3	b2	b1	b0																																																						
SW0160	16	15	14	13	to	4	3	2	1																																																						
SW0161	32	31	30	29	to	20	19	18	17																																																						
SW0162	48	47	46	45	to	36	35	34	33																																																						
SW0163	64	63	62	61	to	52	51	50	49																																																						
SW0183 (783 <sub>H</sub> )	Transmission speed test result	<p>Indicates the execution result of the transmission speed test. 0: Normal Other than 0: Stores an error code (refer to  Page 358, Section 15.3).</p>	○	○	×																																																										

Appendix 3 Link Special Relays and Registers (SB/SW)  
Appendix 3.2 Link special registers (SW)

Number	Name	Description	Availability (○: Available, ×: Not available)																																																	
			Online		Offline																																															
			Master station	Local station																																																
SW0184 (784 <sub>H</sub> )	Transmission speed test result for each station*2	Indicates transmission speed test results by station numbers. 0: Normal (Same transmission speed as that of master station), or no response from the module 1: Abnormal (Different transmission speed from that of master station)	○	×	×																																															
SW0185 (785 <sub>H</sub> )																																																				
SW0186 (786 <sub>H</sub> )																																																				
SW0187 (787 <sub>H</sub> )																																																				
		<table border="1"> <thead> <tr> <th></th> <th>b15</th> <th>b14</th> <th>b13</th> <th>b12</th> <th>to</th> <th>b3</th> <th>b2</th> <th>b1</th> <th>b0</th> </tr> </thead> <tbody> <tr> <td>SW0184</td> <td>16</td> <td>15</td> <td>14</td> <td>13</td> <td>to</td> <td>4</td> <td>3</td> <td>2</td> <td>1</td> </tr> <tr> <td>SW0185</td> <td>32</td> <td>31</td> <td>30</td> <td>29</td> <td>to</td> <td>20</td> <td>19</td> <td>18</td> <td>17</td> </tr> <tr> <td>SW0186</td> <td>48</td> <td>47</td> <td>46</td> <td>45</td> <td>to</td> <td>36</td> <td>35</td> <td>34</td> <td>33</td> </tr> <tr> <td>SW0187</td> <td>64</td> <td>63</td> <td>62</td> <td>61</td> <td>to</td> <td>52</td> <td>51</td> <td>50</td> <td>49</td> </tr> </tbody> </table> <p>Numbers 1 to 64 in the above table indicate the station numbers.</p>		b15	b14	b13	b12	to	b3	b2	b1	b0	SW0184	16	15	14	13	to	4	3	2	1	SW0185	32	31	30	29	to	20	19	18	17	SW0186	48	47	46	45	to	36	35	34	33	SW0187	64	63	62	61	to	52	51	50	49
	b15	b14	b13	b12	to	b3	b2	b1	b0																																											
SW0184	16	15	14	13	to	4	3	2	1																																											
SW0185	32	31	30	29	to	20	19	18	17																																											
SW0186	48	47	46	45	to	36	35	34	33																																											
SW0187	64	63	62	61	to	52	51	50	49																																											

- \*1 Can be used for the standby master station only.
- \*2 Only the bit for the first station number is turned on.
- \*3 This register checks and stores the status only at link startup.
- \*4 Bits for the number of occupied stations are turned on.
- \*5 Only the bit for the first station number is turned on. The status is checked and stored only at link startup and at parameter update.
- \*6 The other station data link status (SW0080 to SW0083) takes up to 6 seconds to turn on after a slave station connected to the master/local station becomes faulty.  
The time to turn ON differs according to the system configuration, faulty status or other conditions.
- \*7 Parameter setting is required in the case of a standby master station.

The timing when the data in a link special register (SW) is updated differs depending on the link register number. The following table lists the update timings of link special registers.

Link special register	Data update timing	Link special register	Data update timing
SW0041	Updated independently regardless of SB	SW0071	Updated independently regardless of SB (Update after each station is stabilized.)
SW0045		SW0072	
SW0060	When SB0060 changes	SW0074 to SW0077	When SB0074 changes
SW0061	When SB0061 changes	SW0078 to SW007B	When SB0075 changes
SW0062	Updated independently regardless of SB	SW0080 to SW0083	When SB0080 changes
SW0067		SW0088 to SW008B	Updated independently regardless of SB
SW0068		SW0090	When SB0090 changes
SW0069		SW0098 to SW009B	Updated independently regardless of SB
SW006A		SW009C to SW009F	
SW006D		SW00B4 to SW00B7	
SW006E		SW00B8	
SW006F		—	—
SW0070		—	—

A

## Appendix 4 Data Link Processing Time

---

This chapter explains the data link processing time such as the link scan time and transmission delay time.

The retry processing time (RT) and return processing time (F), which are included in the expression, do not need to be added if all CC-Link system stations are correctly data-linked.

### Appendix 4.1 Link scan time

---

This section explains the CC-Link scan time. The following describes the method for calculating the normal value and maximum value for the remote net mode or remote I/O net mode.

[Link scan time (LS)]

**(1) For remote net mode**

$$LS = BT \{27 + (NI \times 4.8) + (NW \times 9.6) + (N \times 30) + (ni \times 4.8) + (nw \times 9.6) + TR\} + ST + EX + RT + F [\mu s]$$

BT: Constant (transmission speed)

Transmission speed	156kbps	625kbps	2.5Mbps	5Mbps	10Mbps
BT	51.2	12.8	3.2	1.6	0.8

NI	The final station number in A, B and C (It includes the number of dedicated stations but excludes the reserved stations, and must be a multiple of 8.) A: Last station number of remote I/O stations B: Last station number of remote device stations (including the number of occupied stations) C: Last station number of local, standby master and intelligent device stations (including the number of occupied stations)
NW	The final station number in B and C (Includes the number of dedicated stations but excludes the reserved stations, and must be a multiple of 8.)

Final station number	1 to 8	9 to 16	17 to 24	25 to 32	33 to 40	41 to 48	49 to 56	57 to 64
NI, NW	8	16	24	32	40	48	56	64

N	Number of connected stations (excluding reserved stations)
ni	a + b + c (excluding reserved stations)
a	Total number of occupied stations for remote I/O stations
b	Total number of occupied stations for remote device stations
c	Total number of occupied stations for local stations, standby master station and intelligent device stations
nw	b + c (excluding reserved stations)
TR	Transient processing time (only when a transient request is made) <ul style="list-style-type: none"> <li>• When there is a transient request from the master station 180</li> <li>• When there is a transient request from the local station <math>40.8 \times</math> number of transient transmission stations</li> </ul>

ST	Constant (The largest value found in 1) to 3) below. However, 2) is disregarded when B = 0 and 3) is disregarded when C = 0) 1) $800 + (A \times 15)$ 2) $900 + (B \times 50)$ 3) For $C \leq 26$ : $1200 + (C \times 100)$ , For $C > 26$ : $3700 + \{(C - 26) \times 25\}$
EX	Constant (only when remote net ver.2 mode or remote net additional mode is used) 50 + total in the following table

Expanded cyclic setting	Number of occupied stations			
	Occupies 1 station	Occupies 2 stations	Occupies 3 stations	Occupies 4 stations
single	0	0	0	0
double	$70 \times \text{Number of stations}$	$80 \times \text{Number of stations}$	$90 \times \text{Number of stations}$	$100 \times \text{Number of stations}$
quadruple	$90 \times \text{Number of stations}$	$110 \times \text{Number of stations}$	$130 \times \text{Number of stations}$	$150 \times \text{Number of stations}$
octuple	$110 \times \text{Number of stations}$	$160 \times \text{Number of stations}$	$210 \times \text{Number of stations}$	$260 \times \text{Number of stations}$

RT	Retry processing time (only link scans whose slave stations became abnormal are added) $\alpha + \beta \times (\text{number of stations with communication error detected} - 1)$	
	$\alpha$	Retry processing time on the first station $BY \times \{(200 + R) \times \text{setting value of the number of retries} + 178.5\}$ <ul style="list-style-type: none"> <li>• When a transient request is made R: <math>13.2 + (NI \times 4.8) + (NW \times 9.6) + 180</math></li> <li>• When no transient request is made R: <math>13.2 + (NI \times 4.8) + (NW \times 9.6)</math></li> </ul>
	$\beta$	Retry processing time on the second and subsequent stations $BT \times \{(200 + P) \times \text{setting value of the number of retries} + 178.5\}$ P: 10.8
F	Return processing time (only stations with communication errors are added) $BT \times \{243.1 + 210.8 \times (\text{number of automatic return modules} - 1)\} + ST$	

**Ex** Using the following system configuration when the transmission speed is 10 Mbps (assuming that there is no faulty station or transient transmission.)

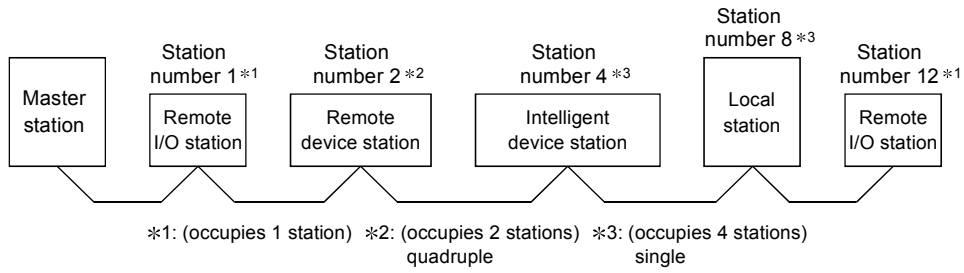

BT	0.8
NI	12→16
NW	11→16
N	5
ni	12
nw	10
ST	2300 1) $800 + (12 \times 15) = 980$ 2) $900 + (3 \times 50) = 1050$ 3) $1200 + (11 \times 100) = 2300$ A = 12, B = 3, C = 11
EX	$50 + 110 \times 1 = 160$

$$\begin{aligned}
 LS &= 0.8 \{27 + (16 \times 4.8) + (16 \times 9.6) + (5 \times 30) + (12 \times 4.8) + (10 \times 9.6)\} + 2300 + 160 \\
 &= 2908.8 \text{ } [\mu\text{s}] \\
 &= 2.91 \text{ } [\text{ms}]
 \end{aligned}$$

## (2) For remote I/O net mode

$$LS = BT \{27 + (NI \times 4.8) + (N \times 30) + (ni \times 4.8)\} + ST + RT + F \text{ [}\mu\text{s]}$$

BT: Constant (transmission speed)

Transmission speed	156kbps	625kbps	2.5Mbps	5Mbps	10Mbps
BT	51.2	12.8	3.2	1.6	0.8

NI: Final station number (must be a multiple of 8)

Final station number	1 to 8	9 to 16	17 to 24	25 to 32	33 to 40	41 to 48	49 to 56	57 to 64
NI	8	16	24	32	40	48	56	64

N	Number of connected modules
ni	Total number of occupied stations
ST	Constant $250 + (ni \times 10)$
RT	Retry processing time (only link scans whose slave stations became abnormal are added) $\alpha + \beta \times (\text{number of stations with communication error detected} - 1)$
$\alpha$	Retry processing time on the first station $BT \times (778.5 + R \times 3)$ R: $13.2 + (NI \times 4.8)$
$\beta$	Retry processing time on the second and subsequent stations $BT \times (778.5 + P \times 3)$ P: 10.8
F	Return processing time (only stations with communication errors are added) $BT \times 243.1 + ST$

**Ex.** Using the following system configuration when the transmission speed is 10 Mbps (assuming that there is no faulty station or retry)

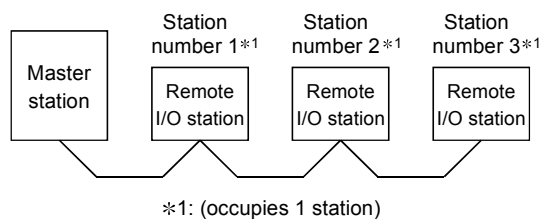

BT	0.8
NI	3→8
N	3
ni	3
ST	$ST = 250 + (ni \times 10) = 250 + (3 \times 10) = 280$

$$\begin{aligned}
 LS &= 0.8 \{27 + (8 \times 4.8) + (3 \times 30) + (3 \times 4.8)\} + 280 \\
 &= 415.84 \text{ [}\mu\text{s]} \\
 &= 0.42 \text{ [ms]}
 \end{aligned}$$



## Appendix 4.2 Transmission delay time of master station <-> remote I/O station

A

### (1) Master station (RX) ← Remote I/O station (input)

This indicates the time from the moment a signal is input to a remote I/O station until the corresponding CPU device turns ON (OFF).

#### (a) Expression

The meanings of symbols in the table are as follows:

- SM : Master station sequence scan time
- LS : Link scan time
- n:  $LS \div SM$  (Digits past the decimal point are rounded up to the nearest integer.)
- Rio: Remote I/O response time

Calculation value	With block guarantee of cyclic data per station		Without block guarantee of cyclic data per station	
	Asynchronous mode	Synchronous mode	Asynchronous mode	Synchronous mode
Normal value	$(SM \times n) + (LS \times 1) + Rio$	$\{(SM \times n) \times 1\} + Rio$	$SM + (LS \times 1) + Rio$	$\{(SM \times n) \times 1\} + Rio$
Max. value	$(SM \times n) + (LS \times 2) + Rio$	$\{(SM \times n) \times 2\} + Rio$	$SM + (LS \times 2) + Rio$	$\{(SM \times n) \times 2\} + Rio$

#### (b) Calculation example

Master station sequence scan time of 20ms, link scan time of 3ms, and remote I/O response time of 1.5ms

Calculation value	With block guarantee of cyclic data per station		Without block guarantee of cyclic data per station	
	Asynchronous mode	Synchronous mode	Asynchronous mode	Synchronous mode
Normal value	$(20 \times 1) + (3 \times 1) + 1.5 = 24.5\text{ms}$	$\{(20 \times 1) \times 1\} + 1.5 = 21.5\text{ms}$	$20 + (3 \times 1) + 1.5 = 24.5\text{ms}$	$\{(20 \times 1) \times 1\} + 1.5 = 21.5\text{ms}$
Max. value	$(20 \times 1) + (3 \times 2) + 1.5 = 27.5\text{ms}$	$\{(20 \times 1) \times 2\} + 1.5 = 41.5\text{ms}$	$20 + (3 \times 2) + 1.5 = 27.5\text{ms}$	$\{(20 \times 1) \times 2\} + 1.5 = 41.5\text{ms}$

## (2) Master station (RY) → Remote I/O station (output)

This indicates the time from the moment a CPU device turns ON (OFF) until a remote I/O station output turns ON (OFF).

### (a) Expression

The meanings of symbols in the table are as follows:

- SM : Master station sequence scan time
- LS: Link scan time
- n:  $LS \div SM$  (Digits past the decimal point are rounded up to the nearest integer.)
- Rio: Remote I/O response time

Calculation value	With block guarantee of cyclic data per station		Without block guarantee of cyclic data per station	
	Asynchronous mode	Synchronous mode	Asynchronous mode	Synchronous mode
Normal value	$(SM \times n) + (LS \times 1) + Rio$	$(SM \times n) + (LS \times 1) + Rio$	$SM + (LS \times 1) + Rio$	$(SM \times n) + (LS \times 1) + Rio$
Max. value	$(SM \times n) + (LS \times 2) + Rio$	$(SM \times n) + (LS \times 2) + Rio$	$SM + (LS \times 2) + Rio$	$(SM \times n) + (LS \times 2) + Rio$

### (b) Calculation example

Master station sequence scan time of 20ms, link scan time of 3ms, and remote I/O response time of 1.5ms

Calculation value	With block guarantee of cyclic data per station		Without block guarantee of cyclic data per station	
	Asynchronous mode	Synchronous mode	Asynchronous mode	Synchronous mode
Normal value	$(20 \times 1) + (3 \times 1) + 1.5 = 24.5\text{ms}$	$(20 \times 1) + (3 \times 1) + 1.5 = 24.5\text{ms}$	$20 + (3 \times 1) + 1.5 = 24.5\text{ms}$	$(20 \times 1) + (3 \times 1) + 1.5 = 24.5\text{ms}$
Max. value	$(20 \times 1) + (3 \times 2) + 1.5 = 27.5\text{ms}$	$(20 \times 1) + (3 \times 2) + 1.5 = 27.5\text{ms}$	$20 + (3 \times 2) + 1.5 = 27.5\text{ms}$	$(20 \times 1) + (3 \times 2) + 1.5 = 27.5\text{ms}$

## Appendix 4.3 Transmission delay time of master station <-> remote device station (Ver.1 compatible slave station)

A

### (1) Master station (RX) ← Remote device station (RX), (RWr)

This indicates the time from when a signal is input to a remote device station until the corresponding CPU device turns ON (OFF) or CPU device data is changed.

#### (a) Expression

The meanings of symbols in the table are as follows:

- SM : Master station sequence scan time
- LS: Link scan time
- n:  $LS \div SM$  (Digits past the decimal point are rounded up to the nearest integer.)
- Rd: Remote device station processing time

Calculation value	With block guarantee of cyclic data per station		Without block guarantee of cyclic data per station	
	Asynchronous mode	Synchronous mode	Asynchronous mode	Synchronous mode
Normal value	$(SM \times n) + (LS \times 1) + Rd$	$\{(SM \times n) \times 1\} + Rd$	$SM + (LS \times 1) + Rd$	$\{(SM \times n) \times 1\} + Rd$
Max. value	$(SM \times n) + (LS \times 2) + Rd$	$\{(SM \times n) \times 2\} + Rd$	$SM + (LS \times 2) + Rd$	$\{(SM \times n) \times 2\} + Rd$

#### (b) Calculation example

Master station sequence scan time of 20ms, link scan time of 3ms, and remote device station processing time of 1.5ms

Calculation value	With block guarantee of cyclic data per station		Without block guarantee of cyclic data per station	
	Asynchronous mode	Synchronous mode	Asynchronous mode	Synchronous mode
Normal value	$(20 \times 1) + (3 \times 1) + 1.5 = 24.5\text{ms}$	$\{(20 \times 1) \times 1\} + 1.5 = 21.5\text{ms}$	$20 + (3 \times 1) + 1.5 = 24.5\text{ms}$	$\{(20 \times 1) \times 1\} + 1.5 = 21.5\text{ms}$
Max. value	$(20 \times 1) + (3 \times 2) + 1.5 = 27.5\text{ms}$	$\{(20 \times 1) \times 2\} + 1.5 = 41.5\text{ms}$	$20 + (3 \times 2) + 1.5 = 27.5\text{ms}$	$\{(20 \times 1) \times 2\} + 1.5 = 41.5\text{ms}$

## (2) Master station (RY) → Remote device station (RY), (RWr)

This indicates the time from when the CPU device turns ON (OFF) until the remote device station output turns ON (OFF), or the time from when data are set to a CPU device until the corresponding data on the remote device station is changed.

### (a) Expression

The meanings of symbols in the table are as follows:

- SM : Master station sequence scan time
- LS: Link scan time
- n:  $LS \div SM$  (Digits past the decimal point are rounded up to the nearest integer.)
- Rd: Remote device station processing time

Calculation value	With block guarantee of cyclic data per station		Without block guarantee of cyclic data per station	
	Asynchronous mode	Synchronous mode	Asynchronous mode	Synchronous mode
Normal value	$(SM \times n) + (LS \times 1) + Rd$	$(SM \times n) + (LS \times 1) + Rd$	$SM + (LS \times 1) + Rd$	$(SM \times n) + (LS \times 1) + Rd$
Max. value	$(SM \times n) + (LS \times 2) + Rd$	$(SM \times n) + (LS \times 2) + Rd$	$SM + (LS \times 2) + Rd$	$(SM \times n) + (LS \times 2) + Rd$

### (b) Calculation example

Master station sequence scan time of 20ms, link scan time of 3ms, and remote device station processing time of 1.5ms

Calculation value	With block guarantee of cyclic data per station		Without block guarantee of cyclic data per station	
	Asynchronous mode	Synchronous mode	Asynchronous mode	Synchronous mode
Normal value	$(20 \times 1) + (3 \times 1) + 1.5 = 24.5\text{ms}$	$(20 \times 1) + (3 \times 1) + 1.5 = 24.5\text{ms}$	$20 + (3 \times 1) + 1.5 = 24.5\text{ms}$	$(20 \times 1) + (3 \times 1) + 1.5 = 24.5\text{ms}$
Max. value	$(20 \times 1) + (3 \times 2) + 1.5 = 27.5\text{ms}$	$(20 \times 1) + (3 \times 2) + 1.5 = 27.5\text{ms}$	$20 + (3 \times 2) + 1.5 = 27.5\text{ms}$	$(20 \times 1) + (3 \times 2) + 1.5 = 27.5\text{ms}$

## Appendix 4.4 Transmission delay time of master station <-> remote device station (Ver.2 compatible slave station)

A

### (1) Master station (RX) ← Remote device station (RX), (RWr)

This indicates the time from when a signal is input to a remote device station until the corresponding CPU device turns ON (OFF) or CPU device data is changed.

#### (a) Expression

The meanings of symbols in the table are as follows:

- SM: Master station sequence scan time
- LS: Link scan time
- n:  $LS \div SM$  (Digits past the decimal point are rounded up to the nearest integer.)
- t:  $LS \times m \div SM$  (Digits past the decimal point are rounded up to the nearest integer.)
- Rd: Remote device station processing time
- m: Constant set in the extended cyclic setting

Expanded cyclic setting	Single	Double	Quadruple	Octuple
m	1	3	7	15

Calculation value	With block guarantee of cyclic data per station		Without block guarantee of cyclic data per station	
	Asynchronous mode	Synchronous mode	Asynchronous mode	Synchronous mode
Normal value	$(SM \times n) + (LS \times 1 \times m) + Rd$	$\{(SM \times t) \times 1\} + Rd$	$SM + (LS \times 1 \times m) + Rd$	$\{(SM \times t) \times 1\} + Rd$
Max. value	$(SM \times n) + (LS \times 2 \times m) + Rd$	$\{(SM \times t) \times 2\} + Rd$	$SM + (LS \times 2 \times m) + Rd$	$\{(SM \times t) \times 2\} + Rd$

#### (b) Calculation example

Master station sequence scan time of 20ms, link scan time of 3ms, and the expanded cyclic setting "double".

Calculation value	With block guarantee of cyclic data per station		Without block guarantee of cyclic data per station	
	Asynchronous mode	Synchronous mode	Asynchronous mode	Synchronous mode
Normal value	$(20 \times 1) + (3 \times 1 \times 3) + 1.5 = 30.5\text{ms}$	$\{(20 \times 1) \times 1\} + 1.5 = 21.5\text{ms}$	$20 + (3 \times 1 \times 3) + 1.5 = 30.5\text{ms}$	$\{(20 \times 1) \times 1\} + 1.5 = 21.5\text{ms}$
Max. value	$(20 \times 1) + (3 \times 2 \times 3) + 1.5 = 39.5\text{ms}$	$\{(20 \times 1) \times 2\} + 1.5 = 41.5\text{ms}$	$20 + (3 \times 2 \times 3) + 1.5 = 39.5\text{ms}$	$\{(20 \times 1) \times 2\} + 1.5 = 41.5\text{ms}$

## (2) Master station (RY) → Remote device station (RY), (RWr)

This indicates the time from when a CPU device turns ON (OFF) until a remote device station output turns ON (OFF), or the time from when data is set to a CPU device until the corresponding data on the remote device station is changed.

### (a) Expression

The meanings of symbols in the table are as follows:

- SM : Master station sequence scan time
- LS: Link scan time
- n:  $LS \div SM$  (Digits past the decimal point are rounded up to the nearest integer.)
- t:  $LS \times m \div SM$  (Digits past the decimal point are rounded up to the nearest integer.)
- Rd: Remote device station processing time
- m: Constant set in the extended cyclic setting

Expanded cyclic setting	Single	Double	Quadruple	Octuple
m	1	3	7	15

Calculation value	With block guarantee of cyclic data per station		Without block guarantee of cyclic data per station	
	Asynchronous mode	Synchronous mode	Asynchronous mode	Synchronous mode
Normal value	$(SM \times n) + [LS \times \{(1 \times m) + 1\}] + Rd$	$(SM \times t) + (LS \times m) + Rd$	$SM + [LS \times \{(1 \times m) + 1\}] + Rd$	$(SM \times t) + (LS \times m) + Rd$
Max. value	$(SM \times n) + [LS \times \{(2 \times m) + 1\}] + Rd$	$(SM \times t) + (LS \times m) + Rd$	$SM + [LS \times \{(2 \times m) + 1\}] + Rd$	$(SM \times t) + (LS \times m) + Rd$

### (b) Calculation example

Master station sequence scan time of 20ms, link scan time of 3ms, and the expanded cyclic setting "double".

Calculation value	With block guarantee of cyclic data per station		Without block guarantee of cyclic data per station	
	Asynchronous mode	Synchronous mode	Asynchronous mode	Synchronous mode
Normal value	$(20 \times 1) + [3 \times \{(1 \times 3) + 1\}] + 1.5 = 33.5\text{ms}$	$(20 \times 1) + (3 \times 3) + 1.5 = 30.5\text{ms}$	$20 + [3 \times \{(1 \times 3) + 1\}] + 1.5 = 33.5\text{ms}$	$(20 \times 1) + (3 \times 3) + 1.5 = 30.5\text{ms}$
Max. value	$(20 \times 1) + [3 \times \{(2 \times 3) + 1\}] + 1.5 = 42.5\text{ms}$	$(20 \times 1) + (3 \times 3) + 1.5 = 30.5\text{ms}$	$20 + [3 \times \{(2 \times 3) + 1\}] + 1.5 = 42.5\text{ms}$	$(20 \times 1) + (3 \times 3) + 1.5 = 30.5\text{ms}$

## Appendix 4.5 Transmission delay time of master station <-> local station (Ver.1 compatible slave station)

### (1) Master station (RX) ← Local station (RY), Master station (RWr) ← Local station (RWw)

This indicates the time from the moment a local station CPU device turns ON (OFF) until the corresponding master station CPU device turns ON (OFF).

Or, it indicates the time from when data is set in a local station CPU device until data is stored to a master station CPU device.

#### (a) Expression

The meanings of symbols in the table are as follows:

- SM : Master station sequence scan time
- LS: Link scan time
- SL: Local station sequence scan time
- n:  $LS \div SM$  (Digits past the decimal point are rounded up to the nearest integer.)
- k:  $LS \div SL$  (Digits past the decimal point are rounded up to the nearest integer.)

Calculation value	With block guarantee of cyclic data per station		Without block guarantee of cyclic data per station	
	Asynchronous mode	Synchronous mode	Asynchronous mode	Synchronous mode
Normal value	$(SM \times n) + (LS \times 2) + \{SL \times (k + 1)\}$	$\{(SM \times n) \times 2\} + LS + \{SL \times (k + 1)\}$	$SM + (LS \times 2) + SL$	$\{(SM \times n) \times 2\} + LS + SL$
Max. value	$(SM \times n) + (LS \times 3) + \{SL \times (k + 1)\}$	$\{(SM \times n) \times 3\} + LS + \{SL \times (k + 1)\}$	$SM + (LS \times 3) + SL$	$\{(SM \times n) \times 3\} + LS + SL$

#### (b) Calculation example

Master station sequence scan time of 20ms, link scan time of 3ms, and local station sequence scan time of 10ms

Calculation value	With block guarantee of cyclic data per station		Without block guarantee of cyclic data per station	
	Asynchronous mode	Synchronous mode	Asynchronous mode	Synchronous mode
Normal value	$(20 \times 1) + (3 \times 2) + \{10 \times (1 + 1)\} = 46\text{ms}$	$\{(20 \times 1) \times 2\} + 3 + \{10 \times (1 + 1)\} = 63\text{ms}$	$20 + (3 \times 2) + 10 = 36\text{ms}$	$\{(20 \times 1) \times 2\} + 3 + 10 = 53\text{ms}$
Max. value	$(20 \times 1) + (3 \times 3) + \{10 \times (1 + 1)\} = 49\text{ms}$	$\{(20 \times 1) \times 3\} + 3 + \{10 \times (1 + 1)\} = 83\text{ms}$	$20 + (3 \times 3) + 10 = 39\text{ms}$	$\{(20 \times 1) \times 3\} + 3 + 10 = 73\text{ms}$

**(2) Master station (RY) → Local station (RX), Master station (RWw) → Local station (RWr)**

This indicates the time from the moment a master station CPU device turns ON (OFF) until the corresponding local station CPU device turns ON (OFF).

Or, it indicates the time from when data is set to a master station CPU device until data is stored in the corresponding local station CPU device.

**(a) Expression**

The meanings of symbols in the table are as follows:

- SM : Master station sequence scan time
- LS: Link scan time
- SL: Local station sequence scan time
- n:  $LS \div SM$  (Digits past the decimal point are rounded up to the nearest integer.)
- k:  $LS \div SL$  (Digits past the decimal point are rounded up to the nearest integer.)

Calculation value	With block guarantee of cyclic data per station		Without block guarantee of cyclic data per station	
	Asynchronous mode	Synchronous mode	Asynchronous mode	Synchronous mode
Normal value	$(SM \times n) + (LS \times 2) + \{SL \times (k + 1)\}$	$(SM \times n) + (LS \times 2) + \{SL \times (k + 1)\}$	$SM + (LS \times 2) + SL$	$(SM \times n) + (LS \times 2) + SL$
Max. value	$(SM \times n) + (LS \times 3) + \{SL \times (k + 1)\}$	$(SM \times n) + (LS \times 2) + \{SL \times (k + 1)\}$	$SM + (LS \times 3) + SL$	$(SM \times n) + (LS \times 2) + SL$

**(b) Calculation example**

Master station sequence scan time of 20ms, link scan time of 3ms, and local station sequence scan time of 10ms

Calculation value	With block guarantee of cyclic data per station		Without block guarantee of cyclic data per station	
	Asynchronous mode	Synchronous mode	Asynchronous mode	Synchronous mode
Normal value	$(20 \times 1) + (3 \times 2) + \{10 \times (1 + 1)\} = 46\text{ms}$	$(20 \times 1) + (3 \times 2) + \{10 \times (1 + 1)\} = 46\text{ms}$	$20 + (3 \times 2) + 10 = 36\text{ms}$	$(20 \times 1) + (3 \times 2) + 10 = 36\text{ms}$
Max. value	$(20 \times 1) + (3 \times 3) + \{10 \times (1 + 1)\} = 49\text{ms}$	$(20 \times 1) + (3 \times 2) + \{10 \times (1 + 1)\} = 46\text{ms}$	$20 + (3 \times 3) + 10 = 39\text{ms}$	$(20 \times 1) + (3 \times 2) + 10 = 36\text{ms}$



## Appendix 4.6 Transmission delay time of master station <-> local station (Ver.2 compatible slave station)

A

### (1) Master station (RX) ← Local station (RY), Master station (RWr) ← Local station (RWw)

This indicates the time from the moment a local station CPU device turns ON (OFF) until the corresponding master station CPU device turns ON (OFF).

Or, it indicates the time from when data is set to a local station CPU device until the data is stored to the corresponding master station CPU device.

#### (a) Expression

The meanings of symbols in the table are as follows:

- SM: Master station sequence scan time
- LS: Link scan time
- SL: Local station sequence scan time
- n:  $LS \div SM$  (Digits past the decimal point are rounded up to the nearest integer.)
- t:  $LS \times m \div SM$  (Digits past the decimal point are rounded up to the nearest integer.)
- k:  $LS \div SL$  (Digits past the decimal point are rounded up to the nearest integer.)
- m: Constant set in the extended cyclic setting

Expanded cyclic setting	Single	Double	Quadruple	Octuple
m	1	3	7	15

Calculation value	With block guarantee of cyclic data per station		Without block guarantee of cyclic data per station	
	Asynchronous mode	Synchronous mode	Asynchronous mode	Synchronous mode
Normal value	$(SM \times n) + [LS \times \{(1 \times m) + 1\}] + \{SL \times (k + 1)\}$	$\{(SM \times t) \times 2\} + \{SL \times (k + 1)\}$	$SM + [LS \times \{(1 \times m) + 1\}] + SL$	$(SM \times t) \times 2$
Max. value	$(SM \times n) + [LS \times \{(2 \times m) + 1\}] + \{SL \times (k + 1)\}$	$\{(SM \times t) \times 3\} + \{SL \times (k + 1)\}$	$SM + [LS \times \{(2 \times m) + 1\}] + SL$	$(SM \times t) \times 3$

#### (b) Calculation example

Master station sequence scan time of 20ms, link scan time of 3ms, expanded cyclic setting "double", and local station sequence scan time of 10ms

Calculation value	With block guarantee of cyclic data per station		Without block guarantee of cyclic data per station	
	Asynchronous mode	Synchronous mode	Asynchronous mode	Synchronous mode
Normal value	$(20 \times 1) + [3 \times \{(1 \times 3) + 1\}] + \{10 \times (1 + 1)\} = 52\text{ms}$	$\{(20 \times 1) \times 2\} + \{10 \times (1 + 1)\} = 60\text{ms}$	$20 + [3 \times \{(1 \times 3) + 1\}] + 10 = 42\text{ms}$	$(20 \times 1) \times 2 = 40\text{ms}$
Max. value	$(20 \times 1) + [3 \times \{(2 \times 3) + 1\}] + \{10 \times (1 + 1)\} = 61\text{ms}$	$\{(20 \times 1) \times 3\} + \{10 \times (1 + 1)\} = 80\text{ms}$	$20 + [3 \times \{(2 \times 3) + 1\}] + 10 = 51\text{ms}$	$(20 \times 1) \times 3 = 60\text{ms}$

## (2) Master station (RY) → Local station (RX), Master station (RWw) → Local station (RWr)

This indicates the time from the moment a master station CPU device turns ON (OFF) until the corresponding local station CPU device turns ON (OFF).

Or, it indicates the time from when data is set to a master station CPU device until the data is stored to the corresponding local station CPU device.

### (a) Expression

The meanings of symbols in the table are as follows:

- SM: Master station sequence scan time
- LS: Link scan time
- SL: Local station sequence scan time
- n:  $LS \div SM$  (Digits past the decimal point are rounded up to the nearest integer.)
- t:  $LS \times m \div SM$  (Digits past the decimal point are rounded up to the nearest integer.)
- k:  $LS \div SL$  (Digits past the decimal point are rounded up to the nearest integer.)
- m: Constant set in the extended cyclic setting

Expanded cyclic setting	Single	Double	Quadruple	Octuple
m	1	3	7	15

Calculation value	With block guarantee of cyclic data per station		Without block guarantee of cyclic data per station	
	Asynchronous mode	Synchronous mode	Asynchronous mode	Synchronous mode
Normal value	$(SM \times n) + [LS \times \{(1 \times m) + 1\}] + \{SL \times (k + 1)\}$	$\{(SM \times t) \times 1\} + \{SL \times (k + 1)\}$	$SM + [LS \times \{(1 \times m) + 1\}] + SL$	$\{(SM \times t) \times 1\} + SL$
Max. value	$(SM \times n) + [LS \times \{(2 \times m) + 1\}] + \{SL \times (k + 1)\}$	$\{(SM \times t) \times 2\} + \{SL \times (k + 1)\}$	$SM + [LS \times \{(2 \times m) + 1\}] + SL$	$\{(SM \times t) \times 2\} + SL$

### (b) Calculation example

Master station sequence scan time of 20ms, link scan time of 3ms, expanded cyclic setting "double", and local station sequence scan time of 10ms

Calculation value	With block guarantee of cyclic data per station		Without block guarantee of cyclic data per station	
	Asynchronous mode	Synchronous mode	Asynchronous mode	Synchronous mode
Normal value	$(20 \times 1) + [3 \times \{(1 \times 3) + 1\}] + \{10 \times (1 + 1)\} = 52\text{ms}$	$\{(20 \times 1) \times 1\} + \{10 \times (1 + 1)\} = 40\text{ms}$	$20 + [3 \times \{(1 \times 3) + 1\}] + 10 = 42\text{ms}$	$\{(20 \times 1) \times 1\} + 10 = 30\text{ms}$
Max. value	$(20 \times 1) + [3 \times \{(2 \times 3) + 1\}] + \{10 \times (1 + 1)\} = 61\text{ms}$	$\{(20 \times 1) \times 2\} + \{10 \times (1 + 1)\} = 60\text{ms}$	$20 + [3 \times \{(2 \times 3) + 1\}] + 10 = 51\text{ms}$	$\{(20 \times 1) \times 2\} + 10 = 50\text{ms}$

## Appendix 4.7 Transmission delay time of master station <-> intelligent device station

---

A

The transmission delay time between the master station and an intelligent device station varies by the type of intelligent device station used.

Refer to the  User's Manual for the intelligent device module to be used.

# Appendix 4.8 Processing time for dedicated instructions of master station <-> local station

## (1) Master station ↔ local station



This indicates the time from the moment an instruction is issued by the master station until a response from the local station is received.

[Expression]

[Maximum value]

### (a) G(P).RIRD instruction

$$OT + LS \times [BC + \{(read\ points + 16) / 16\}^{*1} \times 1.067] + SL + (WT \times RT \times 1000)^{*2} [ms]$$

OT	Processing time of LCPU dedicated instructions: 0.5 [ms]				
LS	Link scan time (refer to  Page 430, Appendix 4.1.)				
BC	Constant				
Transmission speed	156kbps	625kbps	2.5Mbps	5Mbps	10Mbps
BC	6	7	9	11	12
SL	Local station sequence scan time (0 when reading buffer memory in the CC-Link)				
WT	Monitoring time set in SW0009 (refer to  Page 416, Appendix 3.2.)				
RT	Number of retries set in SW000B (refer to  Page 416, Appendix 3.2.)				

 When the programmable controller CPU type is L26CPU-BT, the transmission speed is 10 Mbps, the link scan time is 5 ms, the read points are 20 words (buffer memory in the CC-Link), the monitoring time is 10 s, and the number of retries is zero.



$$\begin{aligned}
 & OT + LS \times [BC + \{(read\ points + 16) / 16\}^{*1} \times 1.067] + SL + (WT \times RT \times 1000) \\
 &= 0.5 + 5 \times [12 + \{(20 + 16) / 16\}^{*1} \times 1.067] + 0 + (10 \times 0 \times 1000) \\
 &= 0.5 + 5 \times [12 + \{3 \times 1.067\}] + 0 \\
 &= 76.505 \\
 &= 76.5 [ms]
 \end{aligned}$$

\*1 Round up below the decimal point

\*2 Time elapsed when retries of a dedicated instruction occur

**(b) G(P).RIWT instruction**

$$OT + LS \times [BC + \{(write\ points + 16) / 72\}^{*1} \times 1.13] + SL + (WT \times RT \times 1000)^{*2} [ms]$$

OT	Processing time of LCPU dedicated instructions: 0.5 [ms]				
LS	Link scan time (refer to  Page 430, Appendix 4.1.)				
BC	Constant				
Transmission speed	156kbps	625kbps	2.5Mbps	5Mbps	10Mbps
BC	6	7	9	11	12
SL	Local station sequence scan time (0 when writing buffer memory in the CC-Link)				
WT	Monitoring time set in SW0009 (refer to  Page 416, Appendix 3.2.)				
RT	Number of retries set in SW000B (refer to  Page 416, Appendix 3.2.)				

 When the programmable controller CPU type is L26CPU-BT, the transmission speed is 10 Mbps, the link scan time is 5 ms, the write points are 20 words (buffer memory in the CC-Link), the monitoring time is 10 s, and the number of retries is zero.

$$\begin{aligned}
 & OT + LS \times [BC + \{(write\ points + 16) / 72\}^{*1} \times 1.13] + SL + (WT \times RT \times 1000) \\
 &= 0.5 + 5 \times [12 + \{(20 + 16) / 72\}^{*1} \times 1.13] + 0 + (10 \times 0 \times 1000) \\
 &= 0.5 + 5 \times [12 + \{1 \times 1.13\}] + 0 \\
 &= 66.15 \\
 &= 66.2 [ms]
 \end{aligned}$$

\*1 Round up below the decimal point

\*2 Time elapsed when retries of a dedicated instruction occur

## (2) Local station → Master station



This indicates the time from the moment an instruction is issued by the local station until a response from the master station is received.

[Expression]

[Maximum value]

### (a) G(P).RIRD instruction

$$OT + LS \times [BC + \{(read\ points + 16) / 72\}^{*1} \times 1.13] + SM + (WT \times RT \times 1000)^{*2} \text{ [ms]}$$

OT	Processing time of LCPU dedicated instructions: 0.5 [ms]				
LS	Link scan time (refer to  Page 430, Appendix 4.1.)				
BC	Constant				
Transmission speed	156kbps	625kbps	2.5Mbps	5Mbps	10Mbps
BC	6	7	9	11	12
SM	Master station sequence scan time (0 when reading buffer memory in the CC-Link)				
WT	Monitoring time set in SW0009 (refer to  Page 416, Appendix 3.2.)				
RT	Number of retries set in SW000B (refer to  Page 416, Appendix 3.2.)				

 When the programmable controller CPU type is L26CPU-BT, the transmission speed is 10 Mbps, the link scan time is 5 ms, the read points are 20 words (buffer memory in the CC-Link), the monitoring time is 10 s, and the number of retries is zero.



$$\begin{aligned} & OT + LS \times [BC + \{(read\ points + 16) / 72\}^{*1} \times 1.13] + SM + (WT \times RT \times 1000) \\ &= 0.5 + 5 \times [12 + \{(20 + 16) / 72\}^{*1} \times 1.13] + 0 + (10 \times 0 \times 1000) \\ &= 0.5 + 5 \times [12 + \{1 \times 1.13\}] + 0 \\ &= 66.15 \\ &= 66.2 \text{ [ms]} \end{aligned}$$

\*1 Round up below the decimal point

\*2 Time elapsed when retries of a dedicated instruction occur

**(b) G(P).RIWT instruction**

$$OT + LS \times [BC + \{(write\ points + 16) / 16\}^{*1} \times 1.067] + SM + (WT \times RT \times 1000)^{*2} [ms]$$

OT	Processing time of LCPU dedicated instructions: 0.5 [ms]				
LS	Link scan time (refer to  Page 430, Appendix 4.1.)				
BC	Constant				
Transmission speed	156kbps	625kbps	2.5Mbps	5Mbps	10Mbps
BC	6	7	9	11	12
SM	Master station sequence scan time (0 when writing buffer memory in the CC-Link)				
WT	Monitoring time set in SW0009 (refer to  Page 416, Appendix 3.2.)				
RT	Number of retries set in SW000B (refer to  Page 416, Appendix 3.2.)				

 When the programmable controller CPU type is L26CPU-BT, the transmission speed is 10 Mbps, the link scan time is 5ms, the write points are 20 words (buffer memory in the CC-Link), the monitoring time is 10 s, and the number of retries is zero.

$$\begin{aligned}
 & OT + LS \times [BC + \{(write\ points + 16) / 16\}^{*1} \times 1.067] + SM + (WT \times RT \times 1000) \\
 &= 0.5 + 5 \times [12 + \{(20 + 16) / 16\}^{*1} \times 1.067] + 0 + (10 \times 0 \times 1000) \\
 &= 0.5 + 5 \times [12 + \{3 \times 1.067\}] + 0 \\
 &= 76.505 \\
 &= 76.5 [ms]
 \end{aligned}$$

\*1 Round up below the decimal point

\*2 Time elapsed when retries of a dedicated instruction occur

# Appendix 4.9 Processing time for dedicated instructions of local station <-> local station

## (1) Local station → Local station



This indicates the time from the moment an instruction is executed by one local station until a response from another local station is received.

[Expression]

[Maximum value]

### (a) G(P).RIRD instruction

$$OT + LS \times [BC + \{(read\ points + 16) / 16\}^{*1} \times 1.067] + SL + (WT \times RT \times 1000)^{*2} [ms]$$

OT	Processing time of LCPU dedicated instructions: 0.5 [ms]				
LS	Link scan time (refer to  Page 430, Appendix 4.1.)				
BC	Constant				
Transmission speed	156kbps	625kbps	2.5Mbps	5Mbps	10Mbps
BC	6	7	9	11	12
SL	Target station sequence scan time (0 when reading buffer memory in the CC-Link)				
WT	Monitoring time set in SW0009 (refer to  Page 416, Appendix 3.2.)				
RT	Number of retries set in SW000B (refer to  Page 416, Appendix 3.2.)				

 When the programmable controller CPU type is L26CPU-BT, the transmission speed is 10 Mbps, the link scan time is 5 ms, the read points are 20 words (buffer memory in the CC-Link), the monitoring time is 10 s, and the number of retries is zero.

$$\begin{aligned}
 & OT + LS \times [BC + \{(read\ points + 16) / 16\}^{*1} \times 1.067] + SL + (WT \times RT \times 1000) \\
 &= 0.5 + 5 \times [12 + \{(20 + 16) / 16\}^{*1} \times 1.067] + 0 + (10 \times 0 \times 1000) \\
 &= 0.5 + 5 \times [12 + \{3 \times 1.067\}] + 0 \\
 &= 76.505 \\
 &= 76.5 [ms]
 \end{aligned}$$



\*1 Round up below the decimal point

\*2 Time elapsed when retries of a dedicated instruction occur



**(b) G(P).RIWT instruction**

$$OT + LS \times [BC + \{(write\ points + 16) / 16\}^{*1} \times 1.067] + SL + (WT \times RT \times 1000)^{*2} [ms]$$

OT	Processing time of LCPU dedicated instructions: 0.5 [ms]				
LS	Link scan time (refer to  Page 430, Appendix 4.1.)				
BC	Constant				
Transmission speed	156kbps	625kbps	2.5Mbps	5Mbps	10Mbps
BC	6	7	9	11	12
SL	Target station sequence scan time (0 when writing buffer memory in the CC-Link)				
WT	Monitoring time set in SW0009 (refer to  Page 416, Appendix 3.2.)				
RT	Number of retries set in SW000B (refer to  Page 416, Appendix 3.2.)				

 When the programmable controller CPU type is L26CPU-BT, the transmission speed is 10 Mbps, the link scan time is 5 ms, the write points are 20 words (buffer memory in the CC-Link), the monitoring time is 10 s, and the number of retries is zero.

$$\begin{aligned}
 & OT + LS \times [BC + \{(write\ points + 16) / 16\}^{*1} \times 1.067] + SL + (WT \times RT \times 1000) \\
 &= 0.5 + 5 \times [12 + \{(20 + 16) / 16\}^{*1} \times 1.067] + 0 + (10 \times 0 \times 1000) \\
 &= 0.5 + 5 \times [12 + \{3 \times 1.067\}] + 0 \\
 &= 76.505 \\
 &= 76.5 [ms]
 \end{aligned}$$

\*1 Round up below the decimal point

\*2 Time elapsed when retries of a dedicated instruction occur

# Appendix 4.10 Processing time for dedicated instructions of master station <-> intelligent device station

## (1) Master station → Intelligent device station



This indicates the time from the moment an instruction is issued by the master station and a response from an intelligent device station is received.

[Expression]

[Maximum value]

### (a) G(P).RIRD instruction

$$OT + LS \times [BC + \{(read\ points + 16) / 16\}^{*1} \times 1.067] + (WT \times RT \times 1000)^{*2} \text{ [ms]}$$

OT	Processing time of LCPU dedicated instructions: 0.5 [ms]				
LS	Link scan time (refer to  Page 430, Appendix 4.1.)				
BC	Constant				
Transmission speed	156kbps	625kbps	2.5Mbps	5Mbps	10Mbps
BC	6	7	9	11	12
WT	Monitoring time set in SW0009 (refer to  Page 416, Appendix 3.2.)				
RT	Number of retries set in SW000B (refer to  Page 416, Appendix 3.2.)				

**Ex** When the programmable controller CPU type L26CPU-BT, the transmission speed is 10 Mbps, the link scan time is 5 ms, the read points are 20 words, the monitoring time is 10 s, and the number of retries is zero.



$$\begin{aligned}
 & OT + LS \times [BC + \{(read\ points + 16) / 16\}^{*1} \times 1.067] + (WT \times RT \times 1000) \\
 &= 0.5 + 5 \times [12 + \{(20 + 16) / 16\}^{*1} \times 1.067] + (10 \times 0 \times 1000) \\
 &= 0.5 + 5 \times [12 + \{3 \times 1.067\}] + 0 \\
 &= 76.505 \\
 &= 76.5 \text{ [ms]}
 \end{aligned}$$

\*1 Round up below the decimal point

\*2 Time elapsed when retries of a dedicated instruction occur

**(b) G(P).RIWT instruction**

$$OT + LS \times [BC + \{(write\ points + 16) / 72\}^{*1} \times 1.13] + (WT \times RT \times 1000)^{*2} [ms]$$

OT	Processing time of LCPU dedicated instructions: 0.5 [ms]				
LS	Link scan time (refer to  Page 430, Appendix 4.1.)				
BC	Constant				
Transmission speed	156kbps	625kbps	2.5Mbps	5Mbps	10Mbps
BC	6	7	9	11	12
WT	Monitoring time set in SW0009 (refer to  Page 416, Appendix 3.2.)				
RT	Number of retries set in SW000B (refer to  Page 416, Appendix 3.2.)				

 When the programmable controller CPU type is L26CPU-BT, the transmission speed is 10 Mbps, the link scan time is 5 ms, the write points are 20 words, the monitoring time is 10 s, and the number of retries is zero.

$$\begin{aligned}
 & OT + LS \times [BC + \{(write\ points + 16) / 72\}^{*1} \times 1.13] + (WT \times RT \times 1000) \\
 &= 0.5 + 5 \times [12 + \{(20 + 16) / 72\}^{*1} \times 1.13] + (10 \times 0 \times 1000) \\
 &= 0.5 + 5 \times [12 + \{1 \times 1.13\}] + 0 \\
 &= 66.15 \\
 &= 66.2 [ms]
 \end{aligned}$$

\*1 Round up below the decimal point

\*2 Time elapsed when retries of a dedicated instruction occur

# Appendix 4.11 Link refresh time of master station/local station

This section indicates the link refresh time of the master/local station (increase of END processing time at the programmable controller CPU).

## (1) Remote net ver.1 mode, remote net ver.2 mode

[Expression]

$$KM1+KM2 \times \left( \frac{RX+RY+SB}{16} + RWw+RWr+SW \right) + \alpha E + (\text{Number of CC-Link modules}-1) \times KM4 \text{ [ms]}$$

$$\alpha E = KM3 \times \left( \frac{RX+RY+SB}{16} + RWw+RWr+SW \right)$$

- RX: Total points of the remote input (RX) refreshed by the master/local station
- RY: Total points of the remote output (RY) refreshed by the master/local station
- RWw: Total points of the remote register (RWw) refreshed by the master/local station
- RWr: Total points of the remote register (RWr) refreshed by the master/local station
- SB: Total points of the link special relay (SB) refreshed by the master/local station
- SW: Total points of the link special register (SW) refreshed by the master/local station
- $\alpha E$ : Transfer time of the file register (R, ZR), extended data register (D), and extended link register (W) on the standard RAM (only when the registers are used)

KM1, KM2, KM3, KM4: Constant

CPU type	Master station/Local station	KM1	
		With block guarantee of cyclic data per station function set	Without block guarantee of cyclic data per station function set
L02SCPU, L02SCPU-P	Master station	0.32	0.31
	Local station	0.70	0.60
L02CPU, L02CPU-P	Master station	0.16	0.14
	Local station	0.17	0.15
L06CPU, L06CPU-P, L26CPU, L26CPU-P, L26CPU-BT, L26CPU-PBT	Master station	0.14	0.12
	Local station	0.15	0.13
Head module	Master station	0.38	0.20
	Local station	0.65	0.45

CPU type	KM2 ( $\times 10^{-3}$ )		KM3 ( $\times 10^{-3}$ )		KM4
	When connected to a main block	When connected to an extension block	When connected to a main block	When connected to an extension block	
L02SCPU, L02SCPU-P	0.39	1.02	0.03	0.03	0.2
L02CPU, L02CPU-P	0.36	0.85	0.03	0.03	0.14
L06CPU, L06CPU-P, L26CPU, L26CPU-P, L26CPU-BT, L26CPU-PBT	0.36	0.85	0.03	0.03	0.14
Head module	0.35	—	0.05	—	0.2

**Point**

The number of CC-Link modules in the expression includes the built-in CC-Link function.

(Example) When using the L26CPU-BT and the LJ61BT11 is mounted, the number of CC-Link modules counted is two.

**Ex** When the L26CPU-BT is used as the master station, and 2048 points of RX, 2048 points of RY, 256 points of RWw, 256 points of RWr, 512 points of SB and 512 points of SW are refreshed only for the main block.

**(a) When the block guarantee of cyclic data per station is enabled**

$$\begin{aligned}
 \alpha E &= KM3 \times \left( \frac{RX + RY + SB}{16} \right) + RWw + RWr + SW \\
 &= 0.03 \times 10^{-3} \times \left( \frac{2048 + 2048 + 512}{16} \right) + 256 + 256 + 512 \\
 &= 0.03936 \\
 KM1 + KM2 \times \left( \frac{RX + RY + SB}{16} + RWw + RWr + SW \right) + \alpha E \\
 &\quad + (\text{Number of CC-Link modules} - 1) \times KM4 \\
 &= 0.14 + 0.36 \times 10^{-3} \times \left( \frac{2048 + 2048 + 512}{16} + 256 + 256 + 512 \right) + 0.03936 + (1 - 1) \times 0.14 \\
 &= 0.65168 \\
 &= 0.65 \text{ [ms]}
 \end{aligned}$$

**(b) When the block guarantee of cyclic data per station is not enabled**

$$\begin{aligned}
 KM1 + KM2 \times \left( \frac{RX + RY + SB}{16} + RWw + RWr + SW \right) + \alpha E \\
 &\quad + (\text{Number of CC-Link modules} - 1) \times KM4 \\
 &= 0.12 + 0.36 \times 10^{-3} \times \left( \frac{2048 + 2048 + 512}{16} + 256 + 256 + 512 \right) + 0.03936 + (1 - 1) \times 0.14 \\
 &= 0.63168 \\
 &= 0.63 \text{ [ms]}
 \end{aligned}$$

## (2) Remote net additional mode

[Expression]

$$KM1+KM2 \times \left( \frac{RX+RX2+RY+RY2+SB}{16} + RWw+RWw2+RWr+RWr2+SW \right) + \alpha E$$

$$+ (\text{Number of CC-Link modules}-1) \times KM4 \text{ [ms]}$$

$$\alpha E = KM3 \times \left( \frac{RX+RX2+RY+RY2+SB}{16} + RWw+RWw2+RWr+RWr2+SW \right)$$

- RX: Points of the remote input (RX) refreshed by the master/local station  
 RX2: Points of the ver.2 remote input (RX) refreshed by the master/local station  
 RY: Points of the remote output (RY) refreshed by the master/local station  
 RY2: Points of the ver.2 remote output (RY) refreshed by the master/local station  
 RWw: Points of the remote register (RWw) refreshed by the master/local station  
 RWw2: Points of the ver.2 remote register (RWw) refreshed by the master/local station  
 RWr: Points of the remote register (RWr) refreshed by the master/local station  
 RWr2: Points of the ver.2 remote register (RWr) refreshed by the master/local station  
 SB: Points of the link special relay (SB) refreshed by the master/local station  
 SW: Points of the link special register (SW) refreshed by the master/local station  
 αE: Transfer time of the file register (R, ZR), extended data register (D), and extended link register (W) on the standard RAM (only when the registers are used)

KM1, KM2, KM3, KM4: Constant

CPU type	Master station/Local station	KM1	
		With block guarantee of cyclic data per station function set	Without block guarantee of cyclic data per station function set
L02SCPU, L02SCPU-P	Master station	0.88	0.85
	Local station	0.91	0.85
L02CPU, L02CPU-P	Master station	0.20	0.18
	Local station	0.21	0.19
L06CPU, L06CPU-P, L26CPU, L26CPU-P, L26CPU-BT, L26CPU-PBT	Master station	0.18	0.16
	Local station	0.19	0.17
Head module	Master station	0.45	0.26
	Local station	0.71	0.53

CPU type	KM2 (× 10 <sup>-3</sup> )		KM3 (× 10 <sup>-3</sup> )		KM4
	When connected to a main block	When connected to an extension block	When connected to a main block	When connected to an extension block	
L02SCPU, L02SCPU-P	0.33	0.95	0.03	0.03	0.2
L02CPU, L02CPU-P	0.36	0.85	0.03	0.03	0.14
L06CPU, L06CPU-P, L26CPU, L26CPU-P, L26CPU-BT, L26CPU-PBT	0.36	0.85	0.03	0.03	0.14
Head module	0.35	—	0.05	—	0.2

**Point**

The number of CC-Link modules in the expression includes the built-in CC-Link function.

(Example) When using the L26CPU-BT and the LJ61BT11 is mounted, the number of CC-Link modules counted is two.

**Ex** When the L26CPU-BT is used as the master station, and 1024 points of RX, 896 points of RX2, 1024 points of RY, 896 points of RY2, 128 points of RWw, 128 points of RWw2, 128 points of RWr, 128 points of RWr2, 512 points of SB and 512 points of SW are refreshed.

**(a) When the block guarantee of cyclic data per station is enabled**

$$\begin{aligned} \alpha E &= KM3 \times \left( \frac{RX+RX2+RY+RY2+SB}{16} + RWw+RWw2+RWr+RWr2+SW \right) \\ &= 0.03 \times 10^{-3} \times \left( \frac{1024+896+1024+896+512}{16} + 128+128+128+128+512 \right) \\ &= 0.03888 \\ KM1+KM2 &\times \left( \frac{RX+RX2+RY+RY2+SB}{16} + RWw+RWw2+RWr+RWr2+SW \right) + \alpha E \\ &+ (\text{Number of CC-Link modules}-1) \times KM4 \\ &= 0.18+0.36 \times 10^{-3} \times \left( \frac{1024+896+1024+896+512}{16} + 128+128+128+128+512 \right) + 0.03888 \\ &+ (1-1) \times 0.14 \\ &= 0.68544 \\ &= 0.69 \text{ [ms]} \end{aligned}$$



**(b) When the block guarantee of cyclic data per station is not enabled**

$$\begin{aligned} KM1+KM2 &\times \left( \frac{RX+RX2+RY+RY2+SB}{16} + RWw+RWw2+RWr+RWr2+SW \right) + \alpha E \\ &+ (\text{Number of CC-Link modules}-1) \times KM4 \\ &= 0.16+0.36 \times 10^{-3} \times \left( \frac{1024+896+1024+896+512}{16} + 128+128+128+128+512 \right) + 0.03888 \\ &+ (1-1) \times 0.14 \\ &= 0.66544 \\ &= 0.67 \text{ [ms]} \end{aligned}$$

# Appendix 5 How to Confirm the Serial No. and Function Version.

---

For the method to confirm the serial No. and function version, refer to the following manual.

-  MELSEC-L CPU Module User's Manual (Hardware Design, Maintenance and Inspection)
-  MELSEC-L CC-Link IE Field Network Head Module User's Manual



# Appendix 6 Added Functions

A

The following table lists availability of the added function.

Added function	First 5 digits of the serial number of the L series master/local module	GX Works2
Connected devices auto-detection function	14112 or later	1.98C or later

# Appendix 7 Differences Between the L Series Master/Local Module and QJ61BT11N

## Appendix 7.1 Specification comparison

The following lists the specification comparison between the L series master/local module and QJ61BT11N.

Item	Difference		Reference
	L series master/local module	QJ61BT11N	
Automatic CC-Link startup function	<ul style="list-style-type: none"> <li>Type: Master station</li> <li>Transmission speed: 156 kbps</li> </ul>	<ul style="list-style-type: none"> <li>Type: Master or local station</li> <li>Transmission speed: 156 kbps to 10 Mbps</li> </ul>	Page 176, Section 8.3.3
Station number setting, Transmission speed setting, Mode setting	Set this item from "Station No.", "Mode", and "Transmission Speed" of the network parameter.	Set this item from the station number setting switch and transmission speed/mode setting switch.	Page 77, Section 7.3.2
Auto-tracking setting of transmission speed	Available	Not available	Page 99, Section 7.4.2
Connected devices auto-detection function	Available*1	Not available	Page 83, Section 7.3.2 (2)

\*1 To read the model name of the slave stations with the connected devices auto-detection function, refer to the following.  
 iQ Sensor Solution Reference Manual

For the specification comparison between LCPU and QnUCPU, refer to the following manual.

 MELSEC-L CPU Module User's Manual (Function Explanation, Program Fundamentals)

## Appendix 7.2 Precautions when utilizing the program

For utilizing programs, which were used in the Q series system, in the L series, refer to the precautions on utilizing programs, in the following manual.

 MELSEC-L CPU Module User's Manual (Function Explanation, Program Fundamentals)

## Appendix 8 When Using the GX Developer

### Appendix 8.1 Compatible software package

Refer to the following manual.

 MELSEC-L CPU Module User's Manual (Hardware Design, Maintenance and Inspection)

### Appendix 8.2 Operation comparison

The following shows the operating method to use the GX Developer.

For details on the operation of GX Developer, refer to the  Operating Manual of GX Developer.

#### (1) How to operate the wiring check

[Example of wiring check]

Specify the "Remote input (RX)" for the master station to "X1000" and the "Remote output (RY)" to "Y1000" with the GX Developer.

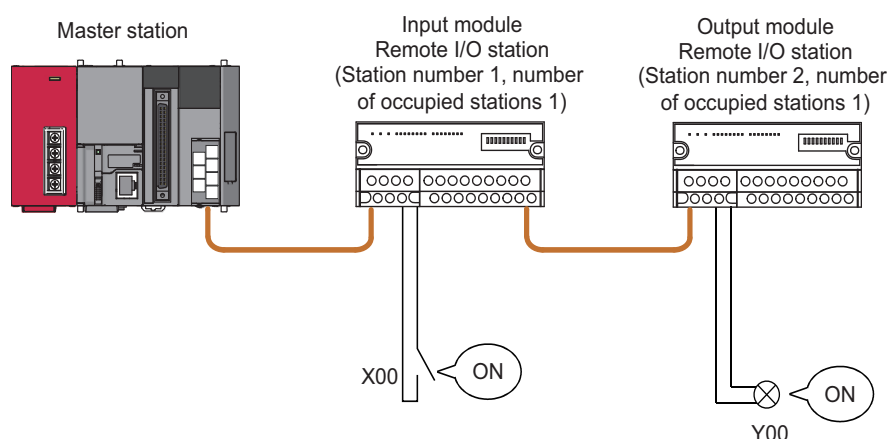

#### (a) Checking the wiring between the input module and an external device

1. Turn ON the switch corresponding to the external device "X0," which is connected to the input module of station number 1.
2. Using the GX Developer, set "X1000" in the "Device:" field by choosing [Online] ⇨ [Monitor] ⇨ [Device batch] and then click on "Start monitor".
3. If X1000 is ON, the connection between the input module and external device has been properly performed.

#### (b) Checking the wiring between the output module and an external device

1. Using the GX Developer, set "Y1020" in the "Device:" field for the "Bit device" by choosing [Online] ⇨ [Debug] ⇨ [Device test] and then click on "FORCE ON".
2. If the connection between the output module and external device is properly performed, the indicator lamp corresponding to the external device "Y00" is lit.

## (2) How to set the temporary error invalid station

Set the [Diagnostics] ⇒ [CC-Link / CC-Link/LT Diagnostics] ⇒ "Monitoring other station ..." ⇒ "Invalid station if temporary error".

Place the cursor at the station to be set as a temporary error invalid station and click "Setting/Cancel".

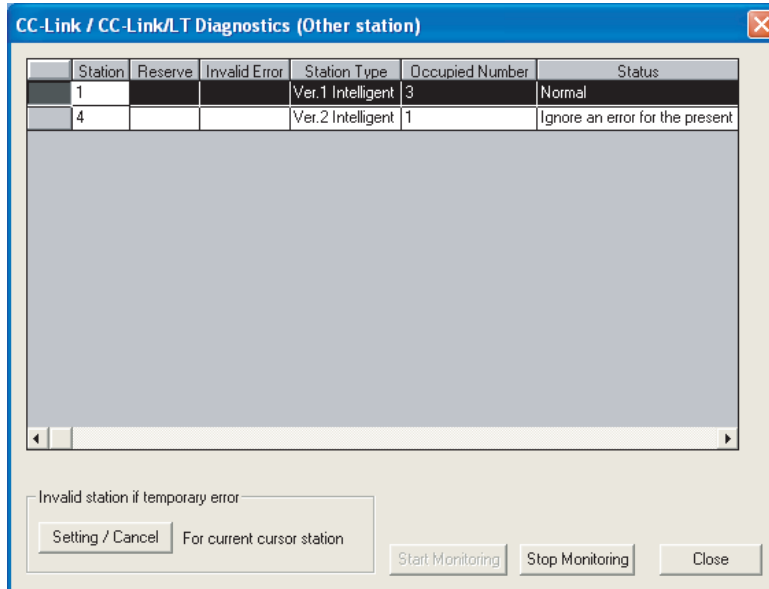

## (3) How to set the data link stop/restart

Set the [Diagnostics] ⇒ [CC-Link / CC-Link/LT Diagnostics].

### (a) Specifying applicable module

Specify the module whose data link is stopped or restarted in "Module setting".  
Specification method: Module No., I/O Address

### (b) Execution of data link stop/restart

Perform these operations by setting "Start Data Link" or "Stop Data Link" in the network test.

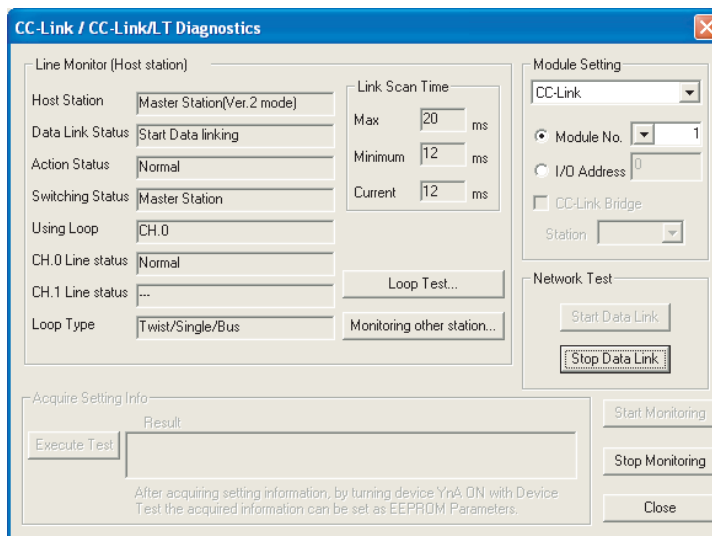

**(4) Operating procedure of the host monitoring**

[Diagnostics] ⇨ [CC-Link / CC-Link/LT diagnostics]

- 1. Select "CC-Link" for "Module Setting".**
- 2. Specify the target module of Host monitoring for "Module No." or "I/O Address".**
- 3. Click the [Start Monitoring] button.**

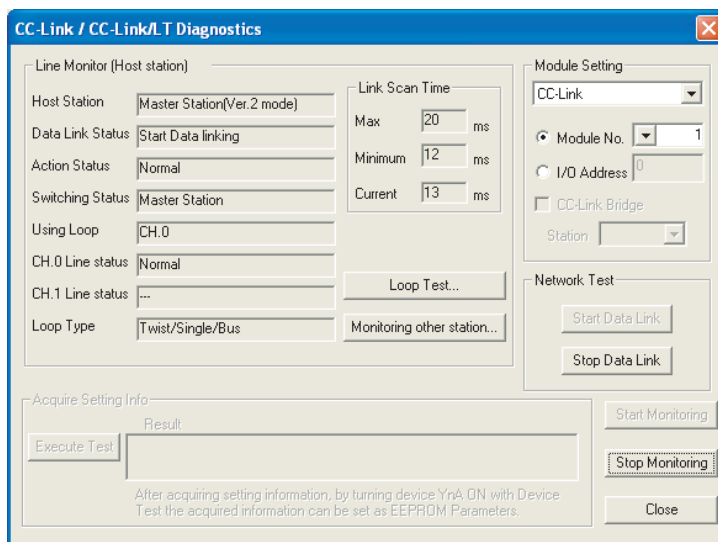

**(5) Operating procedure of the other station monitoring**

[Diagnostics] ⇨ [CC-Link / CC-Link/LT diagnostics]

- 1. Select "CC-Link" for "Module Setting".**
- 2. Specify the target master module of Monitoring other station for "Module No." or "I/O Address".**
- 3. Click the [Start Monitoring] button.**
- 4. Click the [Monitoring other station] button.**

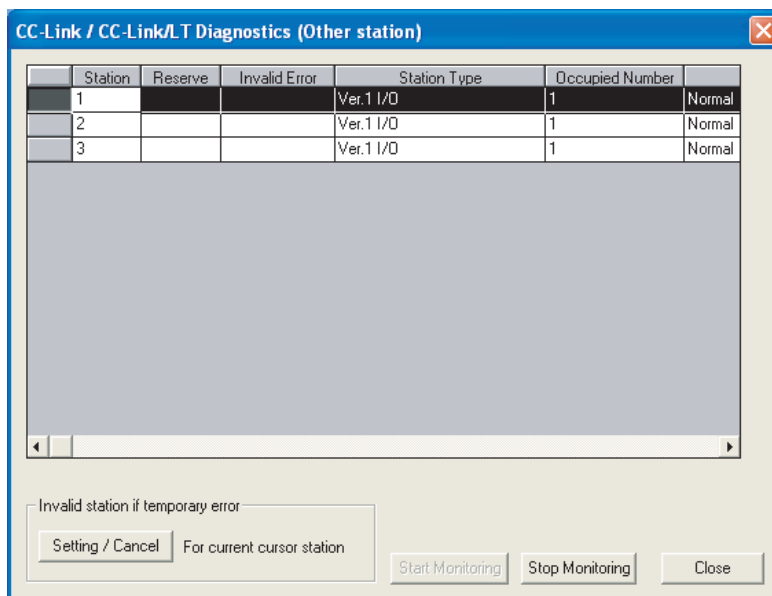

## (6) Operating procedure of the loop test

[Diagnostics] ⇒ [CC-Link / CC-Link/LT diagnostics]

1. Select "CC-Link" for "Module Setting".
2. Specify the target master module of loop test for "Module No." or "I/O Address".
3. Click the [Start Monitoring] button.
4. Click the [Loop Test] button.
5. **When checking the communication status of all stations**  
Select "All stations" for "Target station", and click the [Execute Test] button.
6. **When checking the communication status of specified modules**  
Select "Selected station No." for "Target station", specify the station number, and click the [Execute Test] button.

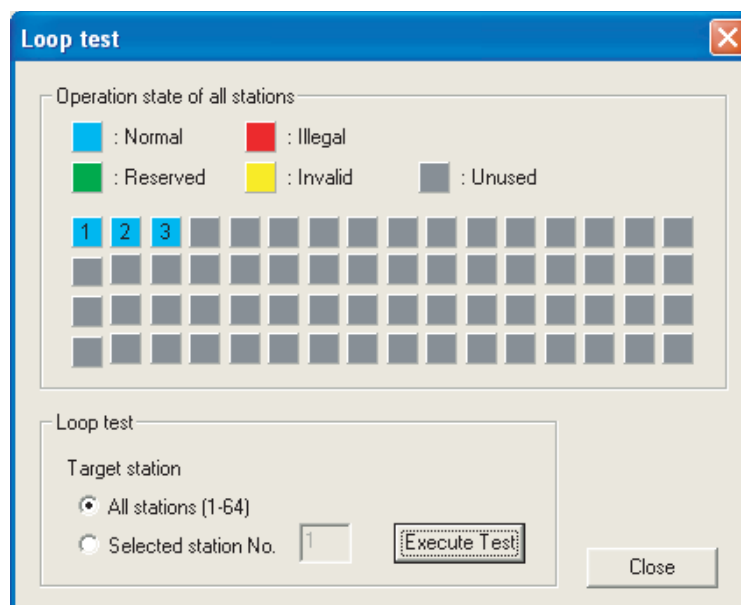

## (7) Operating procedure of the transmission speed test

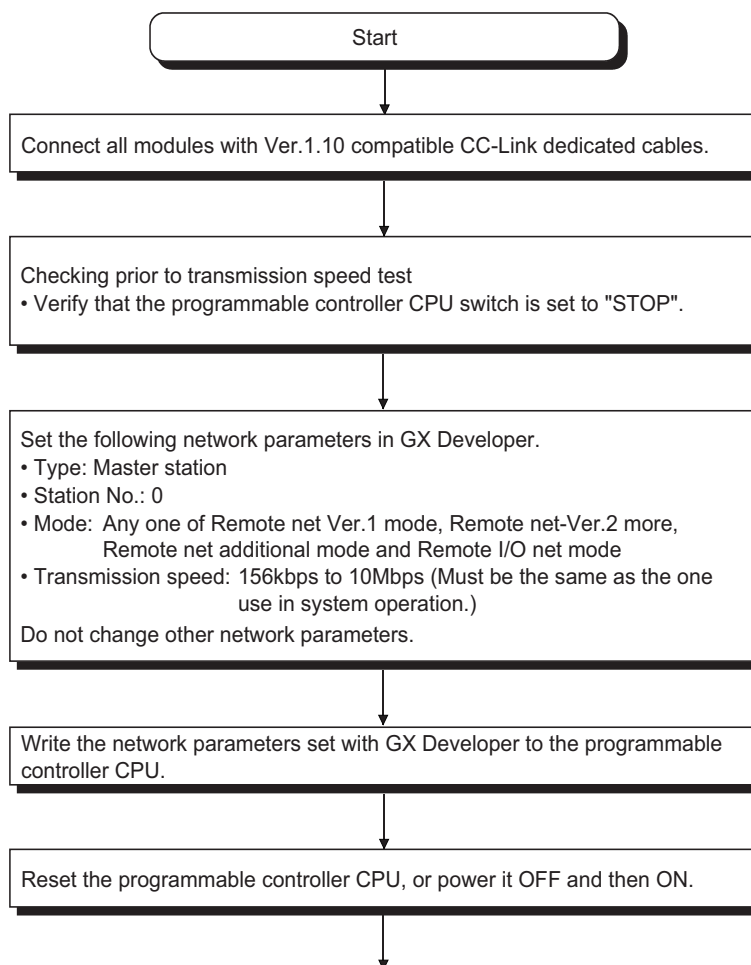

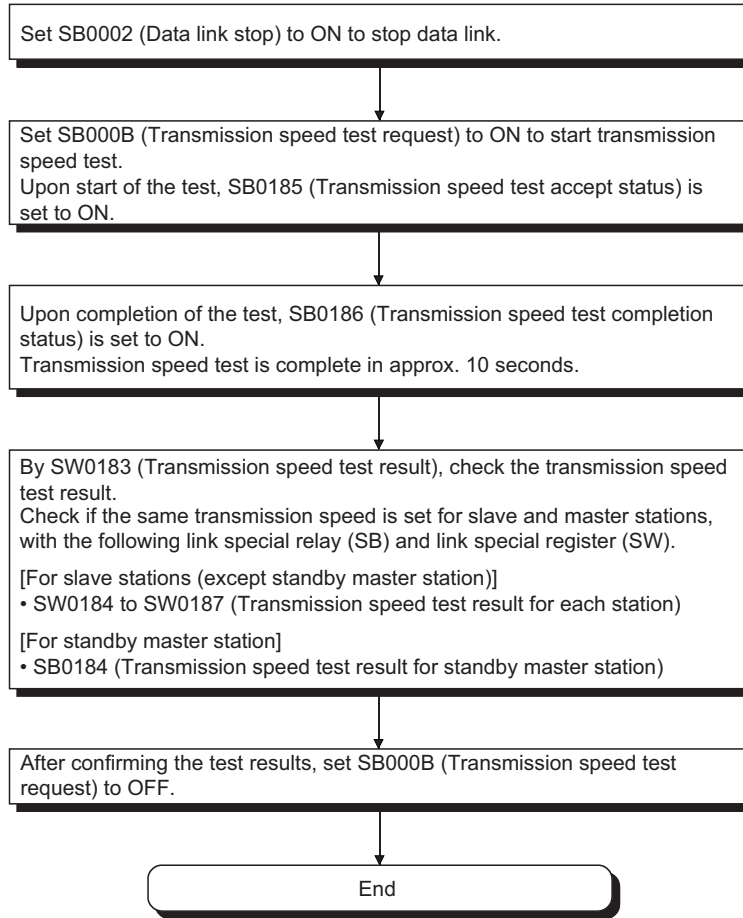

**(a) Timing chart of link special relay (SB) and link special register (SW)**

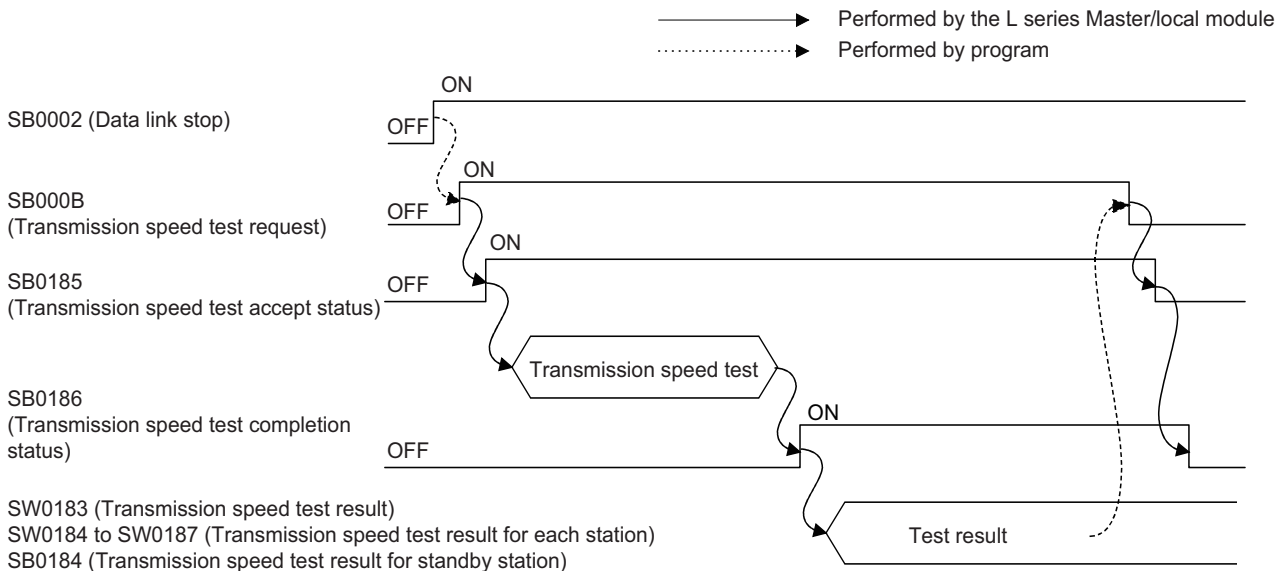



# Appendix 9 External Dimensions

A

The following describes the external dimensions of the LJ61BT11.

For the external dimensions of L26CPU-BT and L26CPU-PBT, refer to the following manual.

 MELSEC-L CPU Module User's Manual (Hardware Design, Maintenance and Inspection)

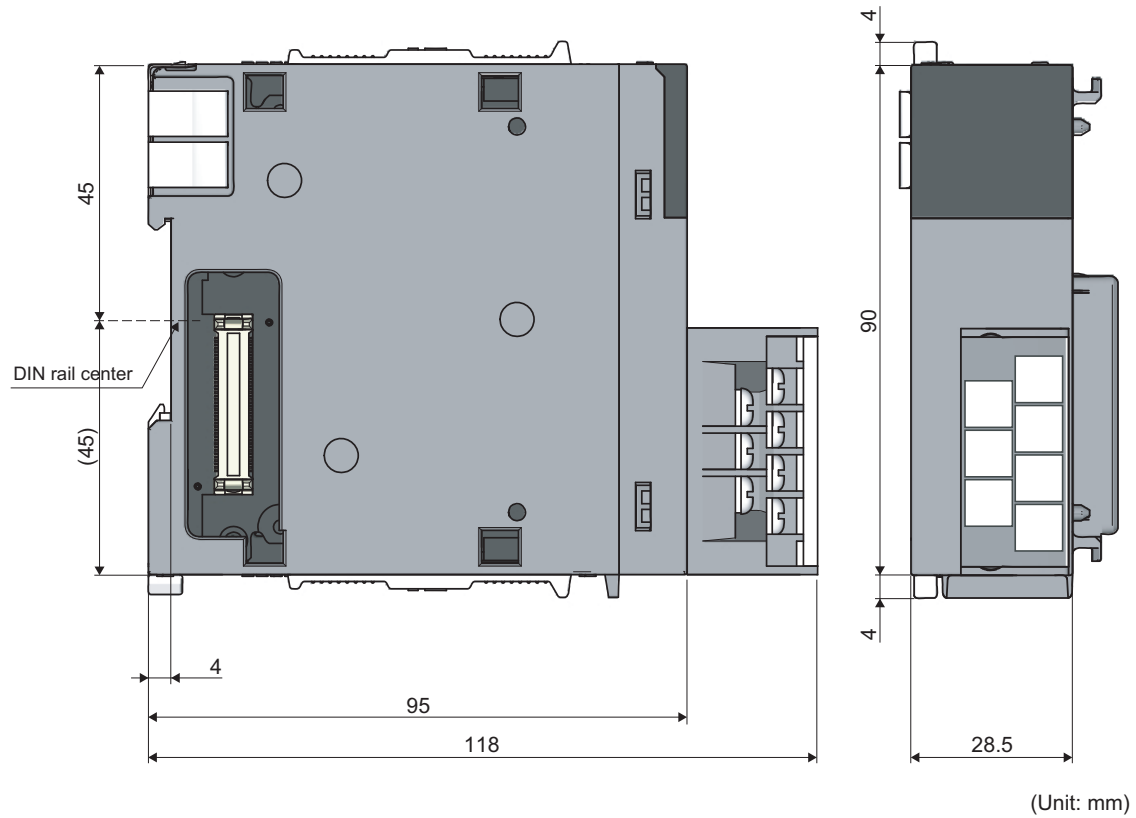

# Memo

---

# INDEX

## A

Applicable system . . . . .	54
Automatic CC-Link startup . . . . .	176
Automatic return function . . . . .	131
Automatic update buffer . . . . .	404

## B

Block guarantee of cyclic data per station . . . . .	159
Buffer memory list . . . . .	47

## C

CC-Link diagnostics . . . . .	375
CC-Link ver. installation/parameter matching status . . . . .	427
Communication between the master station and intelligent device stations . . . . .	323
Communication buffer . . . . .	403
Communication with intelligent device stations . . . . .	124
Communication with local stations . . . . .	118
Communication with remote device stations . . . . .	113
Communication with remote I/O stations . . . . .	110
Compatible CC-Link ver. information . . . . .	426
Completion status of remote device station initialization procedure . . . . .	412
Connectable modules . . . . .	54
Connecting modules . . . . .	62
Connection cable . . . . .	26
CPU monitoring time setting . . . . .	416
Creating a check sheet . . . . .	382
Current link scan time . . . . .	420
Cyclic transmission . . . . .	15

## D

Data link processing time . . . . .	430
Data link restart . . . . .	410
Data link restart acceptance . . . . .	411
Data link restart complete . . . . .	411
Data link restart result . . . . .	417
Data link status setting in case of master station programmable controller CPU failure . . . . .	132
Data link stop . . . . .	410
Data link stop acceptance . . . . .	411
Data link stop complete . . . . .	411
Data link stop result . . . . .	417
Data link stop/restart . . . . .	186
Dedicated instruction list . . . . .	191
Dedicated instructions . . . . .	191
Delay timer information . . . . .	420
Detailed LED display status . . . . .	418,419
Details of the I/O signals . . . . .	387
Differences between the L series master/local module and QJ61BT11N . . . . .	460

## E

EMC Directives . . . . .	8
Error codes . . . . .	358
Error history of the module . . . . .	359
Error invalid station setting function . . . . .	179
Error invalid station specified status . . . . .	413,421
Event issuance for the interrupt program . . . . .	172
Example of communication between the master station and local stations . . . . .	286
Example of communication between the master station and remote device stations . . . . .	249
Example of communication between the master station and remote I/O stations . . . . .	242
Execution status of remote device station initialization procedure . . . . .	412
Expanded cyclic setting . . . . .	37
External dimensions . . . . .	467

## F

Faulty station occurs at certain transmission speeds . . . . .	357
Faulty stations cannot be detected . . . . .	357
Forced master switching . . . . .	411
Forced master switching instruction result . . . . .	419
Forced master switching request acknowledgement . . . . .	412
Forced master switching request complete . . . . .	412
Function list . . . . .	32
Functions . . . . .	110

## H

H/W information . . . . .	384
Handling precautions . . . . .	58
Hardware test . . . . .	60
Host line status . . . . .	415
Host master/standby master operation status . . . . .	414
Host mode . . . . .	412
Host monitoring . . . . .	375
Host parameter status . . . . .	420
Host standby master station setting status . . . . .	412
Host station number . . . . .	419
Host station operation status . . . . .	413
Host station switch change detection . . . . .	414
Host type . . . . .	412
How to confirm the function version . . . . .	458

## I

I/O signal list . . . . .	45
Initial setting of the remote device station . . . . .	265
Input data status of host data link faulty station . . . . .	413
Intelligent device module . . . . .	15
Intelligent device station . . . . .	15
Intelligent device station communication . . . . .	21
Intelligent function module . . . . .	15
Internal current consumption . . . . .	26

<b>L</b>	
LED indicators . . . . .	23
Line status . . . . .	422
Link refresh time . . . . .	454
Link scan time . . . . .	430
Link special registers (SW) . . . . .	403,416
Link special relays (SB) . . . . .	402,410
Loading status . . . . .	420
Loading/parameter consistency status . . . . .	423
Local module . . . . .	15
Local station . . . . .	15
Local station communication . . . . .	20
Loop test . . . . .	67,378
Loop test 1 result . . . . .	424
Loop test acceptance status . . . . .	412
Loop test complete status . . . . .	412
Loop test request . . . . .	410
Loop test result . . . . .	417,424
Loop test station setting . . . . .	416
Loop test/Obtain transmission speed setting . . . . .	378
<b>M</b>	
Master module . . . . .	15
Master station . . . . .	15
Master station duplication error cancel function . . . . .	190
Master station information . . . . .	413
Master station return specification information . . . . .	414
Master station transient transmission status . . . . .	415
Master switching request acknowledgement . . . . .	412
Master switching request complete . . . . .	412
Master/local module . . . . .	15
Max. communication station number . . . . .	421
Max. link scan time . . . . .	420
Maximum number of link points . . . . .	26
Maximum overall cable distance . . . . .	30
Maximum transmission distance . . . . .	26
Min. link scan time . . . . .	420
Mode selection flowchart . . . . .	36
Mode setting status . . . . .	419
Module installation environment and position . . . . .	54,58
Module operating status . . . . .	420
Module status . . . . .	411,417
Monitoring time setting . . . . .	416
Multiple temporary error invalid station specification . . . . .	416
<b>N</b>	
No. of automatic return stations . . . . .	420
No. of retries information . . . . .	420
Number of connected modules . . . . .	421
Number of host occupied stations . . . . .	413
Number of link points per station . . . . .	26
Number of occupied I/O points . . . . .	26
Number of occupied stations . . . . .	26
<b>O</b>	
Offline test status . . . . .	412
Operation specification when CPU is down status . . . . .	413
Other station data link status . . . . .	414,422
Other station fuse blown status . . . . .	414,422
Other station monitoring . . . . .	375
Other station switch change status . . . . .	415,422
Other station watchdog timer error occurrence status . . . . .	422
Other station watchdog timer error status . . . . .	414
Overview of the modes . . . . .	35
<b>P</b>	
Parameter information . . . . .	420
Parameter receive status . . . . .	414
Parameter setting by dedicated instruction . . . . .	72
Parameter setting status . . . . .	413
Parameter settings . . . . .	72
Part names and settings . . . . .	22
Performance specifications . . . . .	26
Precautions on programming . . . . .	241
Precautions on the system configuration . . . . .	55
Procedure before operation . . . . .	50
Processing time for dedicated instructions . . . . .	446
<b>R</b>	
Random access buffer . . . . .	403
RDMSG . . . . .	236
Refresh instruction acknowledgement status at standby master switching . . . . .	411
Refresh instruction at standby master switching . . . . .	410
Refresh instruction at standby master switching result . . . . .	417
Refresh instruction complete status at standby master switching . . . . .	411
Refresh instruction when changing parameters by the dedicated instruction . . . . .	410
Remote device station . . . . .	16
Remote device station communication . . . . .	19
Remote device station initialization procedure registration function . . . . .	165
Remote device station initialization procedure registration instruction . . . . .	411
Remote device station initialization procedure registration instruction result . . . . .	419
Remote I/O net mode . . . . .	16,35
Remote I/O station . . . . .	16
Remote I/O station communication . . . . .	19
Remote I/O station points setting . . . . .	188
Remote input (RX) . . . . .	392
Remote module . . . . .	16
Remote net additional mode . . . . .	16,29,38
Remote net mode . . . . .	16
Remote net ver. 1 mode . . . . .	28
Remote net ver. 2 mode . . . . .	29,37
Remote net Ver.1 mode . . . . .	16
Remote net Ver.2 mode . . . . .	16
Remote output (RY) . . . . .	392
Remote register (RW <sub>r</sub> ) . . . . .	396
Remote register (RW <sub>w</sub> ) . . . . .	396
Remote station . . . . .	16
Reserved station function . . . . .	178
Reserved station specified status . . . . .	413,421
RIFR . . . . .	215
RIRCV . . . . .	205
RIRD . . . . .	193

RISEND	210
RITO	218
RIWT	199
RLPASET	221
RWr	16
RWw	16
RX	16
RY	16

## S

SB	15,410
Scan mode setting information	413
Scan synchronous function	182
Secured 32-bit data	164
Setting status of block guarantee of cyclic data per station	413
Setting the status of input data from a data link faulty station	133
Slave station cut-off function	130
Slave station offset, size information	399
Slave station refresh/compulsory clear setting in case of programmable controller CPU STOP	134
Special function module	16
Standby master function	140
Standby master station	16
Standby master station information	413
Standby master station number	421
Station number overlap status	423
Station number setting	107
Station status at error occurrence	136
Status logging	380
SW	15,416
Switch setting status	413,420
System configuration	52

## T

T-Branch connection	65
Temporary error invalid acceptance status	411
Temporary error invalid canceling acknowledgement status	411
Temporary error invalid canceling complete status	412
Temporary error invalid canceling request	410
Temporary error invalid complete status	411
Temporary error invalid request	410
Temporary error invalid station setting function	180
Temporary error invalid station setting information	414
Temporary error invalid station specification	416
Temporary error invalid station specification cancel result	417
Temporary error invalid station specification result	417
Temporary error invalid status	421
Terminal block	24
Terminal block mounting screw	59
Terminal block screw	59
Terminating resistor	17,66
Tightening torque range	59
Total number of stations	421
Transient transmission	16,191
Transient transmission status	415,423

Transmission delay time	435
Transmission speed	26
Transmission speed auto	108
Transmission speed setting	108
Transmission speed setting status	418
Transmission speed test accept status	415
Transmission speed test completion status	415
Transmission speed test request	411
Transmission speed test result	427
Transmission speed test result for each station	428
Transmission speed test result for standby master station	415
Troubleshooting procedures by GX Works2	339
Troubleshooting procedures with LED	336

## V

Ver.1.10 compatible CC-Link dedicated cable	31
Ver.1-compatible slave station	16
Ver.2 compatible remote input (RX)	405
Ver.2 compatible remote output (RY)	405
Ver.2 compatible remote register (RWr)	407
Ver.2 compatible remote register (RWw)	407
Ver.2-compatible slave station	16

## W

Weight	26
When cyclic data are faulty	353
When disconnecting slave station	345
When operation of the master station is faulty	357
When transient data are faulty	356
Wiring check	64

# REVISIONS

\*The manual number is given on the bottom left of the back cover.

Print date	*Manual number	Revision
January, 2010	SH(NA)-080895ENG-A	First edition
April, 2010	SH(NA)-080895ENG-B	<p>Addition</p> <p>Section 5.2.2, Chapter 14</p> <p>Partial correction</p> <p>RELEVANT MANUALS, TERMS, Section 5.1.1, Chapter 7, Appendix 3.1, Appendix 3.2, Appendix 4.11</p>
February, 2013	SH(NA)-080895ENG-C	<p>Addition</p> <p>Section 9.1.9</p> <p>Partial correction</p> <p>INTRODUCTION, COMPLIANCE WITH EMC AND LOW VOLTAGE DIRECTIVES, RELEVANT MANUALS, TERMS, PACKING LIST, Chapter 2, Section 3.2, 3.4, 3.4.1, 3.6, 5.1.1, Chapter 7, Section 7.2, 7.3, 7.4, 7.5, 8.3.2, 8.3.3, 8.3.7, 9.1.8, 12.1.4, 15.3.2, 15.4.3, Appendix 3.1, 3.2, 4.6, 4.8, 4.9, 4.10, 4.11, 8</p>
October, 2014	SH(NA)-080895ENG-D	<p>Partial correction</p> <p>TERMS, Section 1.1, Chapter 2, Section 3.1, 3.2, 3.3, 3.4.1, 3.6, 5.1.1, 6.2, 6.3, 7.3.2, 7.4.2, 7.5, 8.2.5, 8.2.7, 8.3.2, 9.1.1, 9.1.2, 9.1.3, 9.1.4, 9.1.5, 9.1.6, 9.1.7, 9.1.8, 10.1.1, 12.1.4, 15.3.1, 15.3.2, 15.4.3, Appendix 2, 3.1, 3.2, 4.8, 4.9, 4.10, 4.11, 9</p>
April, 2015	SH(NA)-080895ENG-E	<p>Partial correction</p> <p>TERMS, Section 3.3, Chapter 4, Section 5.2.3, 7.3.2, 8.2.7, 8.2.8, 9.1.1, 9.1.9, 15.1, 15.2, 15.3.2</p>

Japanese Manual Version SH-080880-F

This manual confers no industrial property rights or any rights of any other kind, nor does it confer any patent licenses. Mitsubishi Electric Corporation cannot be held responsible for any problems involving industrial property rights which may occur as a result of using the contents noted in this manual.

# WARRANTY

Please confirm the following product warranty details before using this product.

## **1. Gratis Warranty Term and Gratis Warranty Range**

If any faults or defects (hereinafter "Failure") found to be the responsibility of Mitsubishi occurs during use of the product within the gratis warranty term, the product shall be repaired at no cost via the sales representative or Mitsubishi Service Company.

However, if repairs are required onsite at domestic or overseas location, expenses to send an engineer will be solely at the customer's discretion. Mitsubishi shall not be held responsible for any re-commissioning, maintenance, or testing on-site that involves replacement of the failed module.

[Gratis Warranty Term]

The gratis warranty term of the product shall be for one year after the date of purchase or delivery to a designated place. Note that after manufacture and shipment from Mitsubishi, the maximum distribution period shall be six (6) months, and the longest gratis warranty term after manufacturing shall be eighteen (18) months. The gratis warranty term of repair parts shall not exceed the gratis warranty term before repairs.

[Gratis Warranty Range]

- (1) The range shall be limited to normal use within the usage state, usage methods and usage environment, etc., which follow the conditions and precautions, etc., given in the instruction manual, user's manual and caution labels on the product.
- (2) Even within the gratis warranty term, repairs shall be charged for in the following cases.
  1. Failure occurring from inappropriate storage or handling, carelessness or negligence by the user. Failure caused by the user's hardware or software design.
  2. Failure caused by unapproved modifications, etc., to the product by the user.
  3. When the Mitsubishi product is assembled into a user's device, Failure that could have been avoided if functions or structures, judged as necessary in the legal safety measures the user's device is subject to or as necessary by industry standards, had been provided.
  4. Failure that could have been avoided if consumable parts (battery, backlight, fuse, etc.) designated in the instruction manual had been correctly serviced or replaced.
  5. Failure caused by external irresistible forces such as fires or abnormal voltages, and Failure caused by force majeure such as earthquakes, lightning, wind and water damage.
  6. Failure caused by reasons unpredictable by scientific technology standards at time of shipment from Mitsubishi.
  7. Any other failure found not to be the responsibility of Mitsubishi or that admitted not to be so by the user.

## **2. Onerous repair term after discontinuation of production**

- (1) Mitsubishi shall accept onerous product repairs for seven (7) years after production of the product is discontinued. Discontinuation of production shall be notified with Mitsubishi Technical Bulletins, etc.
- (2) Product supply (including repair parts) is not available after production is discontinued.

## **3. Overseas service**

Overseas, repairs shall be accepted by Mitsubishi's local overseas FA Center. Note that the repair conditions at each FA Center may differ.

## **4. Exclusion of loss in opportunity and secondary loss from warranty liability**

Regardless of the gratis warranty term, Mitsubishi shall not be liable for compensation of damages caused by any cause found not to be the responsibility of Mitsubishi, loss in opportunity, lost profits incurred to the user by Failures of Mitsubishi products, special damages and secondary damages whether foreseeable or not, compensation for accidents, and compensation for damages to products other than Mitsubishi products, replacement by the user, maintenance of on-site equipment, start-up test run and other tasks.

## **5. Changes in product specifications**

The specifications given in the catalogs, manuals or technical documents are subject to change without prior notice.

## TRADEMARKS

Microsoft, Windows, Windows Vista, Windows NT, Windows XP, Windows Server, Visio, Excel, PowerPoint, Visual Basic, Visual C++, and Access are either registered trademarks or trademarks of Microsoft Corporation in the United States, Japan, and other countries.

Intel, Pentium, and Celeron are either registered trademarks or trademarks of Intel Corporation in the United States and other countries.

Ethernet is a trademark of Xerox Corp.

The SD and SDHC logos are either registered trademarks or trademarks of SD-3C, LLC.

All other company names and product names used in this manual are either trademarks or registered trademarks of their respective companies.







SH(NA)-080895ENG-E(1504)MEE

MODEL: LJ61BT11-U-E

MODEL CODE: 13JZ41

## **MITSUBISHI ELECTRIC CORPORATION**

HEAD OFFICE : TOKYO BUILDING, 2-7-3 MARUNOUCHI, CHIYODA-KU, TOKYO 100-8310, JAPAN  
NAGOYA WORKS : 1-14, YADA-MINAMI 5-CHOME, HIGASHI-KU, NAGOYA, JAPAN

When exported from Japan, this manual does not require application to the  
Ministry of Economy, Trade and Industry for service transaction permission.

Specifications subject to change without notice.