

iQ Platform-compatible PAC
Process CPU/Redundant system

MELSEC iQ-R
series

Story



Highly scalable process control

The MELSEC iQ-R Series enables a process control system through its range of CPU modules (up to 1200K steps) integrating advanced PID and general control into one module providing excellent system scalability (from small to large) for a best-fit solution. When paired with a redundant function module, it realizes a redundant control system ideal for applications that require highly reliable control. Various network modules with redundant functionality embedded are also available, further improving reliability.

Extensive visualization and data acquisition

Through its interconnectivity with supervisory control and data acquisition (SCADA) software, extensive plant-wide monitoring and control can be realized.

Highlights

- High availability process control system
- Excellent scalability with four models available (between 80K-1200K steps memory)
- Extensive visualization and data acquisition with Mitsubishi SCADA MC Works64
- Redundancy across multiple levels reduces single-point failures
- GX Works3* integrated engineering software

* Process features such as process tag and faceplate will be supported in the future.

High availability across multiple levels

The MELSEC iQ-R Series redundant system enables high availability at multiple levels in the control system hierarchy, from visualization (SCADA) and control to networks, thereby improving system reliability.

Integrated software simplifies engineering

The integrated engineering software GX Works3* enables programming in multiple languages such as function block diagram (FBD) for process control. Intuitive features for simplifying process control system engineering include process tag label (variable) sharing, simple program structures, and easy project upload/download to the process CPU.

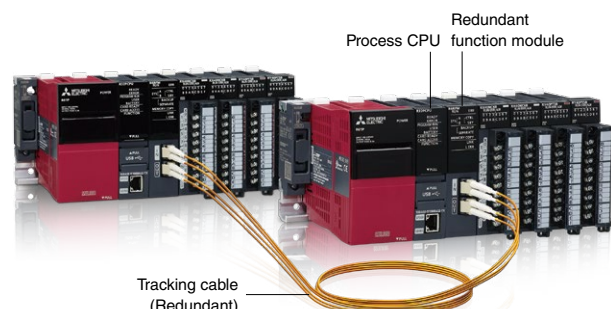



Process

High-available process control in a scalable automation solution

MELSEC iQ-R Series process CPU modules are designed to cover wide-ranging process control applications, from small- to large-scale. All models provide high-speed performance coupled with the ability to handle large PID loops utilizing embedded PID control algorithms; integrating both general and process control into one module. When paired with a redundant function module, a redundant control system ideal for applications that require highly reliable control can be easily realized at a low cost.



Redundant power supply module

- Protects system control from power failure

Remote station 1



CC-Link IE Field

Remote station

Redundant remote network head module

- Enables continuous data communications by switching control between modules

Remote station 2



High availability system

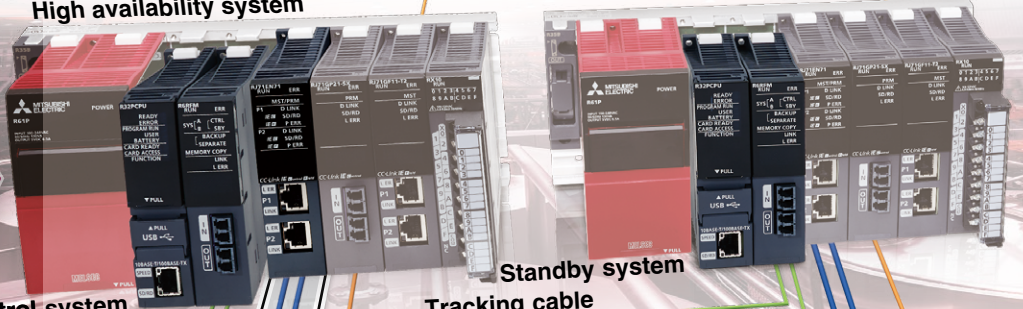

- Highly scalable
- Fast system switching
- Dual tracking cable
- Minimize single-point failure

CC-Link IE Control

Ethernet

SCADA

Redundant Ethernet

- Redundant communication line
- Same IP address settable for both control and standby systems

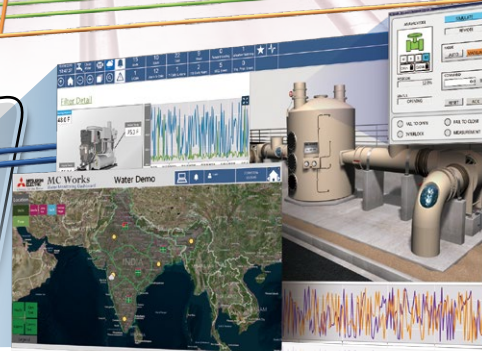

MC Works⁶⁴



Extensive visualization and data acquisition

SCADA

Mitsubishi SCADA MC Works64*1 is a next generation supervisory control and data acquisition (SCADA) software providing extensive visualization with its enhanced interconnectivity with the MELSEC iQ-R Series. Advanced features such as energy management, scheduling, alarm and event management, trending, reporting, historian, and Geo-SCADA monitoring realize intuitive factory-wide control.

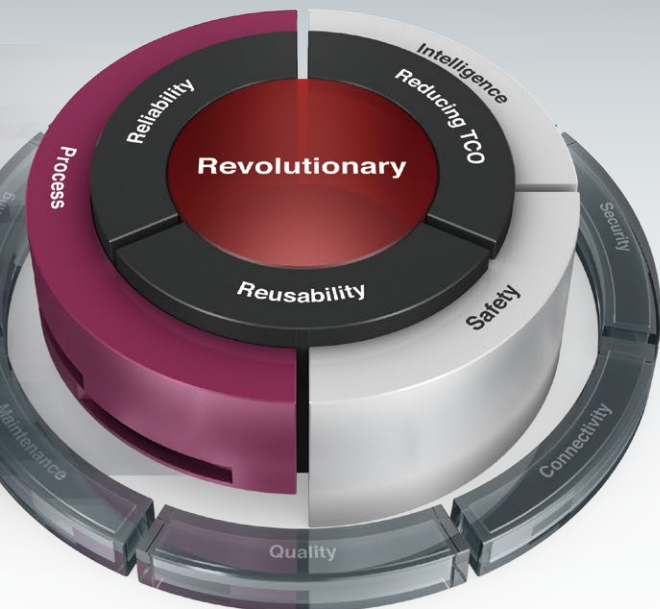

Mitsubishi Electric PAC MELSEC iQ-R
"Process" Movie



Embedded PID algorithms

PID control

The process CPU includes dedicated algorithms such as two-degree-of-freedom PID, sample PI, and auto-tuning support advanced process control.

Extension base unit

- Supports Q Series modules (RQ extension base)



Extension cable



Process control system



GX Works3

One Software, Many Possibilities

Future Support



Multi-level redundancy ensuring continuous control

High availability

Highly reliable control systems can be easily realized minimizing the possibility of single-point failure at the visualization (SCADA), control, and network levels, thereby avoiding system downtime and ensuring continuous control and operation of critical systems.

*1. MC Works64 redundant Ethernet connection will be supported in the future.

*2. Process features such as process tag and faceplate will be supported in the future.



One package process control software

Integrated engineering

GX Works3^{*2}, the standard integrated engineering software for the MELSEC iQ-R Series, makes programming redundant process control systems relatively easy. The program editor uses function block diagram (FBD) language for process control and simplifies system configuration with its intuitive features such as process tag label (variables) sharing, simple program structure, and easy project upload/download to the process CPU.

Process CPU, Redundant function module

R08PCPU R6RFM
R16PCPU
R32PCPU
R120PCPU



- Highly scalable system with four CPU modules available (based on program capacity)
- Realize redundant control system when paired with redundant function module (R6RFM)
- Supports standalone process control when only the CPU is installed
- Dual optical-fiber tracking cable
- Large data tracking capacity up to 1 M word

Specifications

Item	R08PCPU	R16PCPU	R32PCPU	R120PCPU
Control method	Stored program cyclic operation			
I/O control mode	Refresh mode (Direct access I/O is available by specifying direct access I/O (DX, DY).)			
Programming language	Ladder diagram (LD), structured text (ST), function block diagram (FBD), sequential function chart (SFC)*1			
Extended programming language	Function block (FB), label programming (system/local/global)			
Program execution type	Initial, scan, fixed scan, interrupt, standby type			
Number of I/O points [X/Y](point)	4096	4096	4096	4096
Memory capacity				
Program capacity (step)	80K	160K	320K	1200K
Program memory (byte)	320K	640K	1280K	4800K
Device/label memory (ECC type)*2 (byte)	1188K	1720K	2316K	3380K
Data memory (byte)	5M	10M	20M	40M

*1. SFC programming language is not supported when used in redundant mode.

*2. Extended SRAM cassette expands the device/label memory area.

Item	R6RFM
Communication cable	Multi-mode optical cable
Max. distance (m)	550 (when the core outer diameter is 50 μm)
Tracking cable data capacity (word)	1M

Redundant power supply base (including extended temperature models)

R310RB (Main base)
R610RB (Extension base)
R38RB-HT (Main base "extended temp.")
R68RB-HT (Extension base "extended temp.")

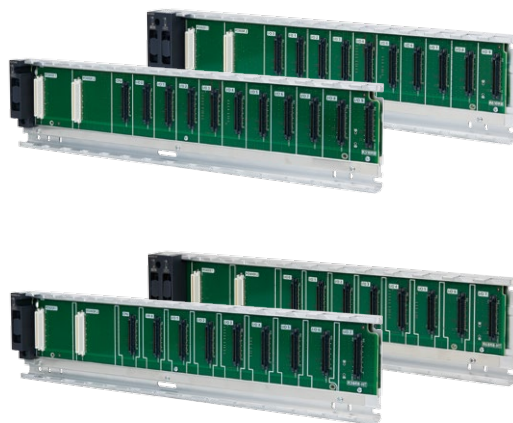

- Enables the installation of redundant power supply modules
- Standard and extended temperature models available
- Utilize standard MELSEC iQ-R Series modules*3

Specifications

Item	Main base unit		Extension base unit	
	R310RB	R38RB-HT	R610RB	R68RB-HT
Number of I/O modules installed	10	8	10	8
DIN rail mounting adapter type	R6DIN1	R6DIN1	R6DIN1	R6DIN1
Redundant power supply support	●	●	●	●
Extended temperature range (0...60°C)*4	-	●	-	●
External dimensions (H x W x D, mm)	101 x 439 x 32.5	101 x 439 x 32.5	101 x 439 x 32.5	101 x 439 x 32.5

*3. Only these base units support the use of redundant power supply modules.

*4. Enables standard MELSEC iQ-R Series modules to support extended operating ambient temperatures of 0 to 60°C when installed.

Redundant power supply module

R63RP
R64RP

- Same size as standard power supply module
- Able to replace while on-line (hot-swap)
- Enables installation of up to two modules simultaneously on the same base unit



Specifications

Item	R63RP	R64RP
Input power supply voltage	24 V DC (19.2...31.2 V DC)	100...240 V AC (85...264 V AC)
Input frequency	-	50/60 Hz ±5%
Max. input apparent power (VA)	-	160
Max. input power (W)	50	-
Rated output current (5 V DC)	6.5	9
Redundant power supply function	●	●

Network modules supporting redundancy

RJ71EN71 (Ethernet multiple network)
RJ71GP21-SX (CC-Link IE Control)
RJ71GF11-T2 (CC-Link IE Field)
RJ72GF15-T2 (CC-Link IE Field remote head)

- Dual Ethernet ports realizing redundant Ethernet communications
- Redundant CC-Link IE Control network (control station), CC-Link IE Field network (master station)
- Redundant CC-Link IE Field head module supports dual network lines



Specifications

Item	RJ71EN71	RJ71GP21-SX	RJ71GF11-T2, RJ72GF15-T2
Transmission speed	1 Gbps	1 Gbps	1 Gbps
Network topology	Line topology, star topology, and ring topology	Duplex loop	Line topology, star topology, and ring topology
Communication cable	Ethernet cable (Category 5e or higher, double shielded/ STP)	Multi-mode optical cable	Ethernet cable (Category 5e or higher, double shielded/ STP)
Communication method	Token-pass	Token-ring	Token-pass
Max. station-to-station distance (m)	100	550 (when the core outer diameter is 50 μm)	100
Overall cable distance (m)	Line: 12,000 (with 121 stations) Star: Depends on system configuration Ring: 12,100 (with 121 stations)	66,000 (core outer diameter is 50 μm) 33,000 (core outer diameter is 62.5 μm)	Line: 12,000 (with 121 stations) Star: Depends on system configuration Ring: 12,100 (with 121 stations)
Max. number of connectable stations	121 (master station: 1, slave station: 120)	120 (control station: 1, normal station: 119)	121 (master station: 1, slave station: 120)
Redundant function	● (Ethernet)	● (CC-Link IE Control network)	● (CC-Link IE Field network)
Maximum link points per network (CC-Link IE Field network)			
Remote input (RX), remote output (RY)	16384 points, 2K bytes	-	16384 points, 2K bytes
Remote register (RWw, RWr)	8192 points, 16K bytes	-	8192 points, 16K bytes
Maximum link points per network (CC-Link IE Control network)			
Link relay (LB)	32768 points, 4K bytes	32768 points, 4K bytes	-
Link register (LW)	131072 points, 256K bytes	131072 points, 256K bytes	-
Link input (LX), link output (LY)	8192 points, 1K bytes	8192 points, 1K bytes	-

Redundant system remote location and high-speed switching

Optical-fiber tracking cables enable the standby system to be installed in a remote location up to 550m from the control (primary) system. The tracking cables are immune to noise interference and support fast data transfer rates. System switching speed has also been improved to speeds of 10 ms or less, enabling high-speed switching of the control system to standby system further improving reliability.

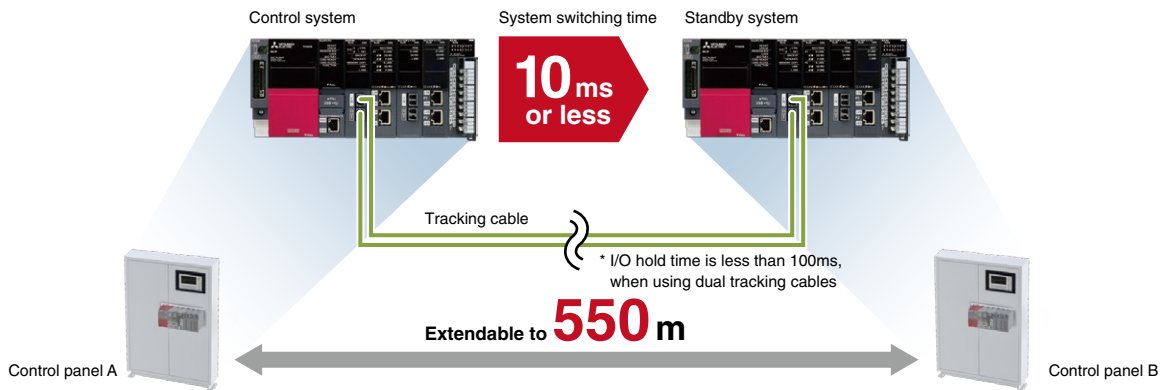

Improve reliability with reduced single-point failure

A multi-level redundant system can be realized by installing dual control systems consisting of the control (primary) and standby CPUs combined with a dual cable topology for the network cabling of the CC-Link IE Field networks, and dual remote stations minimizing the risk of single-point failure. It is also possible to replace modules (hot-swapping) without stopping the operating control system.

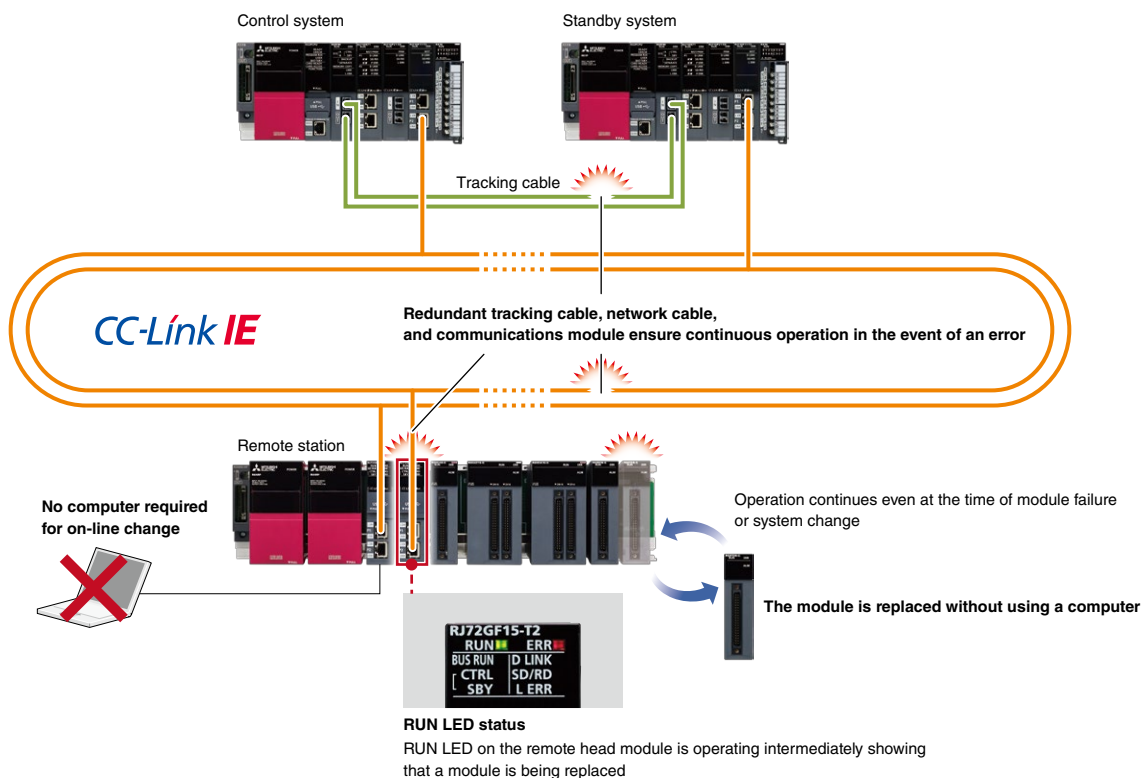

Mitsubishi MC Works64 visualization and redundant Ethernet improving information level reliability*1

Mitsubishi SCADA MC Works64 in combination with MELSEC iQ-R Series redundant system realizes highly reliable visualization and control system. The Ethernet module includes two communications ports which enable information level communications with MC Works64 without switching the system even if an error occurs with one of the ports, in addition to reducing system hardware costs as only one module is required per control and standby system.

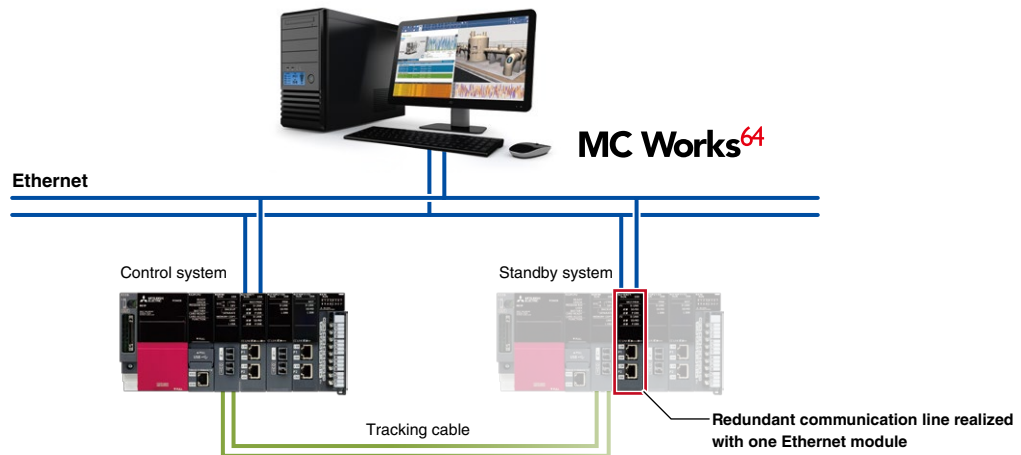

*1. Redundant Ethernet for MC Works64 will be supported in the future.

GX Works3*2 easy programming and automatic memory copy

GX Works3 is the main programming and maintenance software of the MELSEC iQ-R process control system. This integrated software application is equipped with many functions that contribute to reducing engineering time and simplifying commissioning. When installed as a redundant system, the same project can be transferred to the standby system automatically during CPU module replacement without having to upload the project to the new CPU again.

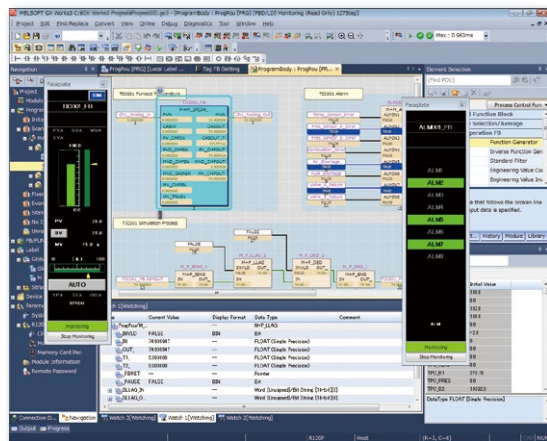
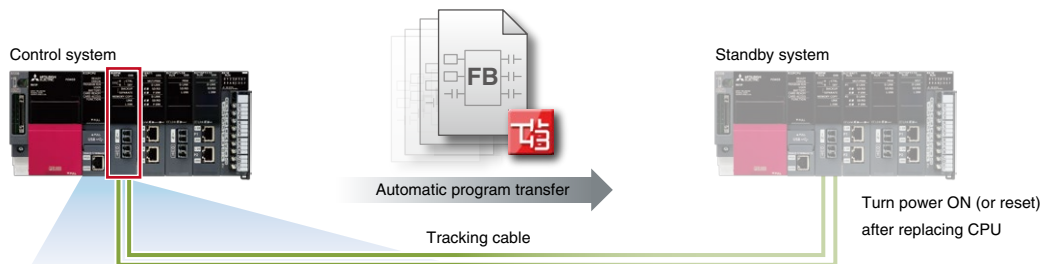

■ GX Works3 (process + ladder logic control)

- Process tag labels (variables) are shared across process and other control programs.
- Simple program structure enables easy upload and download to the process CPU.

GX Works3
One Software, Many Possibilities

*2. Process features such as process tag and faceplate will be supported in the future.

MELSEC iQ-R Series process control used in industry

MELSEC iQ-R Series process CPU/redundant systems are ideal for various industrial process control applications requiring highly reliable process control solutions that can be easily integrated. Most components are based on the standard range of MELSEC iQ-R Series modules, enabling total cost of ownership to be reduced through utilization of its extensive functions and features.

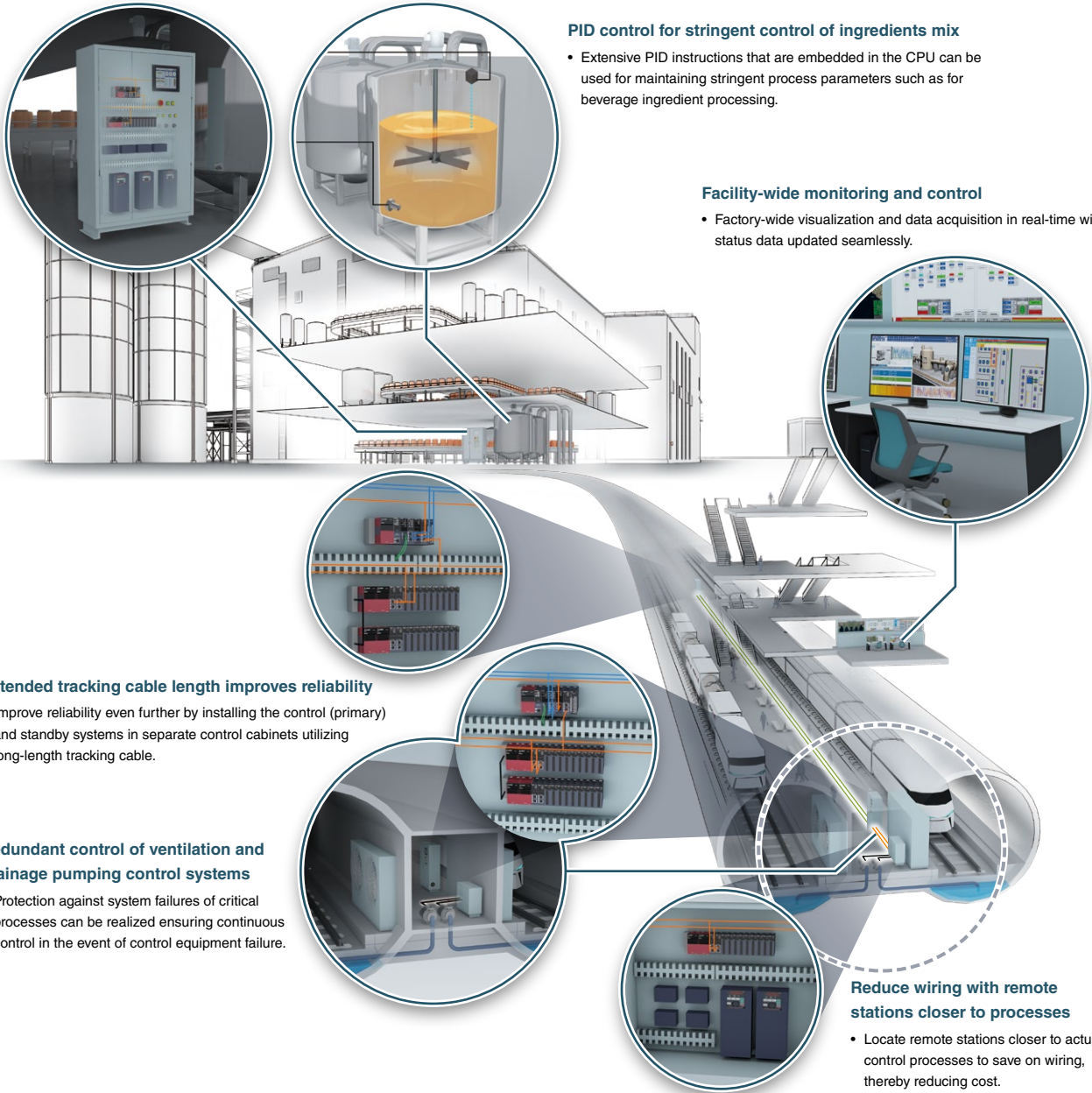

PID control for stringent control of ingredients mix

- Extensive PID instructions that are embedded in the CPU can be used for maintaining stringent process parameters such as for beverage ingredient processing.

Facility-wide monitoring and control

- Factory-wide visualization and data acquisition in real-time with status data updated seamlessly.

Extended tracking cable length improves reliability

- Improve reliability even further by installing the control (primary) and standby systems in separate control cabinets utilizing long-length tracking cable.

Redundant control of ventilation and drainage pumping control systems

- Protection against system failures of critical processes can be realized ensuring continuous control in the event of control equipment failure.

Reduce wiring with remote stations closer to processes

- Locate remote stations closer to actual control processes to save on wiring, thereby reducing cost.

Country/Region Sales Office
 USA +1-847-478-2100
 Mexico +52-55-3067-7500
 Brazil +55-11-4689-3000
 Germany +49-2102-486-0
 UK +44-1707-28-8780
 Ireland +353-1-4198800
 Italy +39-039-60531
 Spain +34-935-65-3131
 France +33-1-55-68-55-68

Czech Republic ... +420-251-551-470
 Poland +48-12-347-65-00
 Sweden +46-8-625-10-00
 Russia +7-812-633-3497
 Turkey +90-216-526-3990
 UAE +971-4-3724716
 South Africa +27-11-658-8100
 China +86-21-2322-3030
 Taiwan +886-2-2299-2499

Korea +82-2-3660-9530
 Singapore +65-6473-2308
 Thailand +66-2682-6522
 Vietnam +84-4-3937-8075
 Indonesia +62-21-3192-6461
 India +91-20-2710-2000
 Australia +61-2-9684-7777

• Company names and product names used in this document are trademarks or registered trademarks of their respective companies.

For safe use

• To use the products listed in this publication properly, always read the relevant manuals before use.

MITSUBISHI ELECTRIC CORPORATION

HEAD OFFICE: TOKYO BLDG., 2-7-3, MARUNOUCHI, CHIYODA-KU, TOKYO 100-8310, JAPAN
www.MitsubishiElectric.com