



INVERTER

Plug-in option

FR-A8NCN

INSTRUCTION MANUAL

ControlNet™

communication function



PRE-OPERATION INSTRUCTIONS	1
INSTALLATION	2
WIRING	3
INVERTER SETTING	4
FUNCTIONS	5
OBJECT MAP DEFINITIONS	6
OBJECT MAP	7
TROUBLESHOOTING	8

Thank you for choosing this Mitsubishi inverter plug-in option.

This Instruction Manual provides handling information and precautions for use of this product. Incorrect handling might cause an unexpected fault. Before using this product, always read this Instruction Manual carefully to use this product correctly.

Please forward this Instruction Manual to the end user.

Safety instructions

Do not attempt to install, operate, maintain or inspect the product until you have read through this Instruction Manual and appended documents carefully and can use the equipment correctly. Do not use this product until you have a full knowledge of the equipment, safety information and instructions. In this Instruction Manual, the safety instruction levels are classified into "Warning" and "Caution".



Warning

Incorrect handling may cause hazardous conditions, resulting in death or severe injury.



Caution

Incorrect handling may cause hazardous conditions, resulting in medium or slight injury, or may cause only material damage.

The **Caution** level may even lead to a serious consequence according to conditions. Both instruction levels must be followed because these are important to personal safety.

◆ Electric Shock Prevention



Warning

- While the inverter power is ON, do not open the front cover or the wiring cover. Do not run the inverter with the front cover or the wiring cover removed. Otherwise you may access the exposed high voltage terminals or the charging part of the circuitry and get an electric shock.
- Do not remove the inverter front cover even if the power supply is disconnected. The only exception for this would be when performing wiring and periodic inspection. You may accidentally touch the charged inverter circuits and get an electric shock.
- Before wiring or inspection, LED indication of the inverter unit operation panel must be switched OFF. Any person who is involved in wiring or inspection shall wait for at least 10 minutes after the power supply has been switched OFF and check that there is no residual voltage using a tester or the like. For some time after the power-OFF, a high voltage remains in the smoothing capacitor, and it is dangerous.
- Any person who is involved in wiring or inspection of this equipment shall be fully competent to do the work.
- The plug-in option must be installed before wiring. Otherwise you may get an electric shock or be injured.
- Do not touch the plug-in option or handle the cables with wet hands. Otherwise you may get an electric shock.
- Do not subject the cables to scratches, excessive stress, heavy loads or pinching. Otherwise you may get an electric shock.

◆ Injury Prevention



Caution

- The voltage applied to each terminal must be the ones specified in the Instruction Manual. Otherwise a burst, damage, etc. may occur.
- The cables must be connected to the correct terminals. Otherwise a burst, damage, etc. may occur.
- The polarity (+ and -) must be correct. Otherwise a burst or damage may occur.
- While power is ON or for some time after power OFF, do not touch the inverter as it will be extremely hot. Touching these devices may cause a burn.

◆ Additional Instructions

The following instructions must be also followed. If the product is handled incorrectly, it may cause unexpected fault, an injury, or an electric shock.

Caution

Transportation and mounting

- Do not install or operate the plug-in option if it is damaged or has parts missing.
- Do not stand or rest heavy objects on the product.
- The mounting orientation must be correct.
- Foreign conductive objects must be prevented from entering the inverter. That includes screws and metal fragments or other flammable substance such as oil.
- If halogen-based materials (fluorine, chlorine, bromine, iodine, etc.) infiltrate into a Mitsubishi product, the product will be damaged. Halogen-based materials are often included in fumigant, which is used to sterilize or disinfect wooden packages. When packaging, prevent residual fumigant components from being infiltrated into Mitsubishi products, or use an alternative sterilization or disinfection method (heat disinfection, etc.) for packaging. Sterilization or disinfection of wooden package should also be performed before packaging the product.

Trial run

- Before starting operation, each parameter must be confirmed and adjusted. A failure to do so may cause some machines to make unexpected motions.

Warning

Usage

- Do not modify the equipment.
- Do not perform parts removal which is not instructed in this manual. Doing so may lead to fault or damage of the product.

Caution

Usage

- When parameter clear or all parameter clear is performed, the required parameters must be set again before starting operations. Because all parameters return to their initial values.
- Static electricity in your body must be discharged before you touch the product.

Maintenance, inspection and parts replacement

- Do not carry out a megger (insulation resistance) test.

Disposal

- The product must be treated as industrial waste.

General instruction

- Many of the diagrams and drawings in this Instruction Manual show the inverter without a cover or partially open for explanation. Never operate the inverter in this manner. The cover must be reinstalled and the instructions in the Instruction Manual must be followed when operating the inverter.



— CONTENTS —

1	PRE-OPERATION INSTRUCTIONS	6
1.1	Unpacking and product confirmation.....	6
1.1.1	Product confirmation	6
1.1.2	SERIAL number check.....	7
1.2	Component names	8
1.3	Status LED (operation status indication)	10
1.4	Specifications	13
2	INSTALLATION	14
2.1	Pre-installation instructions	14
2.2	Installation procedure	16
2.3	MAC ID (node address) setting	19
3	WIRING	20
3.1	Connection to network.....	20
3.2	Wiring.....	22
4	INVERTER SETTING	23
4.1	Parameter list.....	23
4.2	ControlNet communication parameter	24
4.2.1	ControlNet data (Pr.562).....	24
4.2.2	ControlNet baud rate (Pr.346).....	25
4.3	Operation mode setting	27
4.3.1	Operation mode switching and communication startup mode (Pr.79, Pr.340).....	27
4.4	Operation at communication error occurrence	30
4.4.1	Operation selection at communication error occurrence (Pr.500 to Pr.502, Pr.779)	30
4.4.2	Fault and measures	34
4.5	Inverter reset.....	35

4.6	Frequency and speed settings	37
5	FUNCTIONS	38
5.1	Output from the inverter to the network	38
5.2	Input to the inverter from the network	39
6	OBJECT MAP DEFINITIONS	40
6.1	Object model of ControlNet	40
6.2	Data communication type	41
6.2.1	Overview of the I/O communication (polling)	41
6.2.2	Overview of the message communication (Explicit message connection)	42
6.3	Response level	43
6.3.1	Response level of the I/O communication (polling)	43
6.3.2	Response level of the message communication (Explicit message connection)	44
6.4	Recommendation for software developers	44
7	OBJECT MAP	45
7.1	Format of the I/O communication (polling)	45
7.1.1	Output Instance 20 / Input Instance 70	45
7.1.2	Output Instance 21 / Input Instance 71	47
7.1.3	Output Instance 126 / Input Instance 176	49
7.1.4	Output Instance 129 / Input Instance 179	53
7.2	Message communication (Explicit message connection)	57
7.2.1	Class 0x01 (Identity Object)	57
7.2.2	Class 0x04 (Assembly Object)	59
7.2.3	Class 0x06 (Connection Manager Object)	60
7.2.4	Class 0x28 (Motor Data Object)	61
7.2.5	Class 0x29 (Control Management Object)	62
7.2.6	Class 0x2A (AC Drive Object)	65
7.2.7	Class 0xF0 (ControlNet Object)	71
7.2.8	Class 0x66 (Extended Object I)	74
7.2.9	Class 0x67 (Extended Object II)	81



7.2.10	Class 0x70 to 0x79 (Extended Object III)	83
7.2.11	Class 0x80 (Extended Object IV)	84
7.2.12	Class 0x90 to 0x94 (Extended Object V)	87

8 TROUBLESHOOTING **88**

APPENDIX **89**

Appendix 1	EDS file	89
Appendix 2	Error Code List	90



1 PRE-OPERATION INSTRUCTIONS

1.1 Unpacking and product confirmation

Take the plug-in option out of the package, check the product name, and confirm that the product is as you ordered and intact. The product is a plug-in option for the FR-A800 series (standard model and separated converter type). (Not compatible with the IP55 compatible model)

1.1.1 Product confirmation

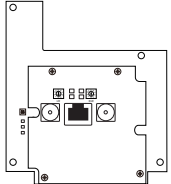
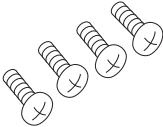
Check the enclosed items.

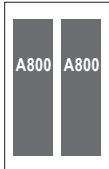
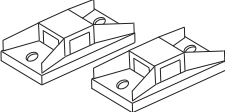
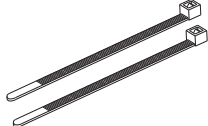
<p>Plug-in option.....1</p> 	<p>Mounting screw (M3 × 8 mm).....4 (Refer to page 16)</p> 	<p>Earth cable.....1 (Refer to page 16)</p> 	<p>Protection seal.....2 *1 (Refer to page 14)</p> 
<p>Cable clamp.....2 (Refer to page 22)</p> 	<p>Cable tie.....2 (Refer to page 22)</p> 	<p>*1 One for a spare.</p>	



- ControlNet is a trademark of ODVA (Open DeviceNet Vender Association, INC).

1.1.2 SERIAL number check

The FR-A8NCN can be used with the inverter models listed below which have the following SERIAL number or later. Check the SERIAL number indicated on the inverter rating plate or package.

Rating plate example

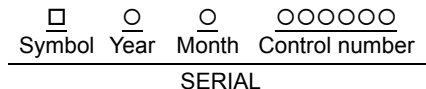
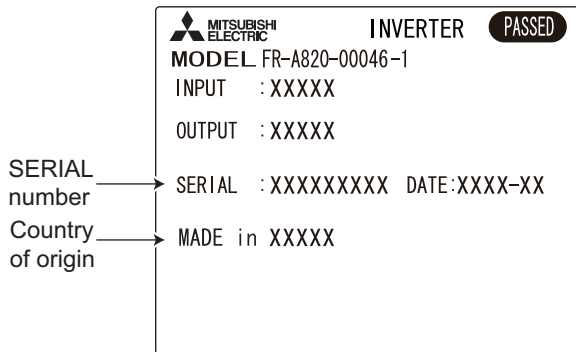

The SERIAL consists of one symbol, two characters indicating the production year and month, and six characters indicating the control number.

The last digit of the production year is indicated as the Year, and the Month is indicated by 1 to 9, X (October), Y (November), or Z (December).

FR-A800 series

Model	Country of origin indication	SERIAL number
FR-A820-00046(0.4K) to 04750(90K) FR-A840-00023(0.4K) to 06830(280K) FR-A842-07700(315K) to 12120(500K) FR-A860-00027 to 04420 FR-A862-05450 to 08500	MADE in Japan	□55○○○○○○ or later
	MADE in China	□56○○○○○○ or later

1.2 Component names

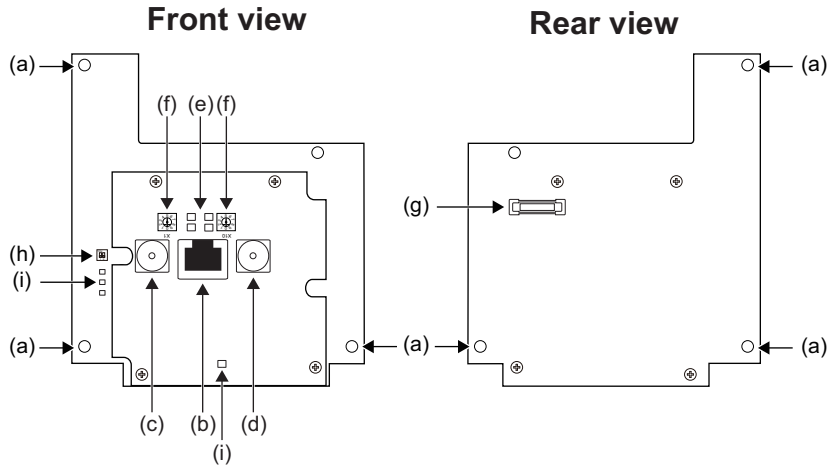

Symbol	Name	Description	Refer to page
a	Mounting hole	Fixes the option to the inverter with screws.	16
b	NAP (Network access port)	RJ-45 connector. The access port through personal computers or servers for maintenance operations such as option unit board diagnosis or program rewriting.	—
c	ControlNet communication connector (Channel A)	Connect to the network by connecting a ControlNet dedicated connection cable.	22
d	ControlNet communication connector (Channel B)		
e	Status LED (operation status indication)	Lit/flicker/off of the LED indicate inverter operation status.	10
f	MAC ID switch	Set the MAC ID. (In the initial setting, "0" is set for both X10 and X1.)	19
g	Connector	Connect to the inverter option connector.	16
h	Switch for manufacturer setting	Switch for manufacturer setting. Do not change from the initially-set status (The switches 1 and 2 are both OFF).	—
i	LED for manufacturer check	Not used.	—

1.3 Status LED (operation status indication)



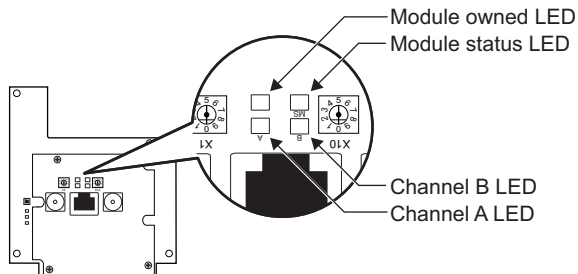







The status LED indicates the operating status and communication status of the option unit according to the indication status of each LED.



◆ Operating specifications of Module status LED

LED indicator	Status of the option unit	Remarks
OFF	Inverter power off	Inverter power is off.
Flickering (green)	Standby	Option unit is being initialized.
ON (green)	Device operation is enabled	Normal status (Operation is enabled.)
Flickering (red)	Alarm	Inverter alarm. When MAC ID was changed while power was on.
ON (red)	Fault	Please contact your sales representative.
Flickering (green/red)	Self-test	During a test execution at power on

◆ Operating specifications of Channel A LED, Channel B LED

Display priority	LED indicator	LED check	LED status example	Factor
1 (highest)	OFF	Check both LEDs.		While the inverter is reset or turned OFF.
2	ON (red)			Link interface failure
3	ON (red/green in turn)		 	Self-test
4	ON (red) / OFF in turn		 	Bad node configuration (Overlapping MAC IDs, etc.)
5	OFF	Check individual LED.		Invalid channel or no channel support
6	Flickering (red/green)			Invalid link configuration
7	Flickering (red)			Link failure or MAC frame has not been received.
8	Flickering (green)			Temporary channel error or listen only
9 (lowest)	ON (green)			Normal operation

■ : Red, ■ : Green, □ : OFF

◆ **Operating specifications of Module owned LED**

LED indication	LED state
OFF	Normal operation of channel
ON (green)	A connection is opened against the module.

1.4 Specifications

Item	Specifications
Operating power supply Network power supply	Supplied from the inverter
Communication speed	Always 5 Mbps
Node address setting	MAC ID • Setting with switch • Setting by parameter
Topology	Bus
Cable	Same shaft cable
Maximum wiring length	Maximum 1000 m
Number of devices connectable	48 units/segment
Connector	BNC connector

2 INSTALLATION

2.1 Pre-installation instructions

- Check that the inverter's input power and the control circuit power are both OFF.
- Remove the inverter front cover and cut off hooks on the rear of the front cover with a nipper, etc. to open up a window for connecting the ControlNet dedicated connecting cable, etc. (Refer to Chapter 2 of the Instruction Manual (Detailed) of the inverter for details on how to remove the front cover.)

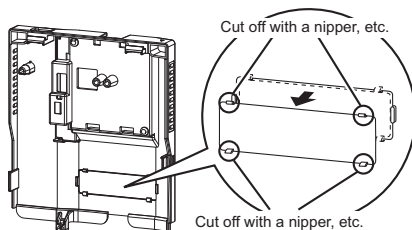

- Align the provided protection seal with vertical slits of the front cover and stick it on the front cover, as shown in the illustration below.

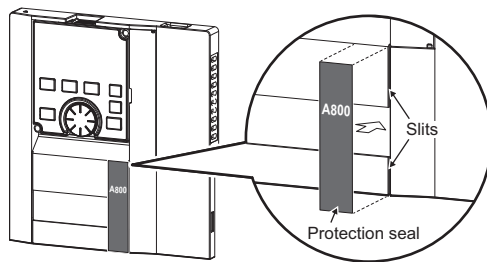

NOTE

- The protective structure (JEM1030) changes to the open type (IP00).

Caution

- With input power ON, do not install or remove the plug-in option. Otherwise, the inverter and plug-in option may be damaged.
- To avoid damage due to static electricity, static electricity in your body must be discharged before you touch the product.
- Take care not to hurt your hand and such with portions left by cutting hooks of the rear of the front cover.
- Do not place/install the inverter with the option installed in intense vibration environment like on a mobile object. Doing so may damage the inverter or plug-in option.

2.2 Installation procedure

◆ Installing the option

- (1) Fit the connector of the plug-in option to the guide of the connector on the inverter unit side, and insert the plug-in option as far as it goes. (Insert it to the inverter option connector 1.)
- (2) Fit the one location on the left of the earth cable (as shown in the next page) securely to the inverter unit by screwing in the supplied mounting screw. (tightening torque 0.33 N·m to 0.40 N·m)
- (3) Fit the two locations on the left of the plug-in option securely to the inverter unit and the right of the plug-in option to the inverter unit together with the earth cable by screwing in the supplied mounting screws. (tightening torque 0.33 N·m to 0.40 N·m) If the screw holes do not line up, the connector may not be inserted deep enough. Check the connector.

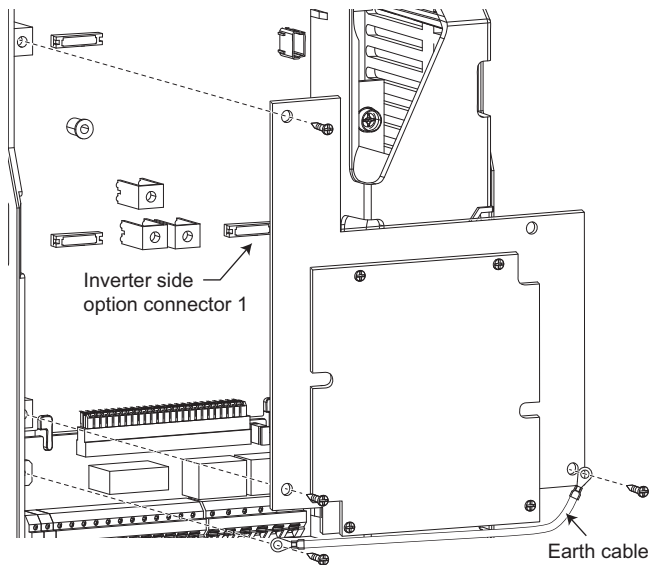

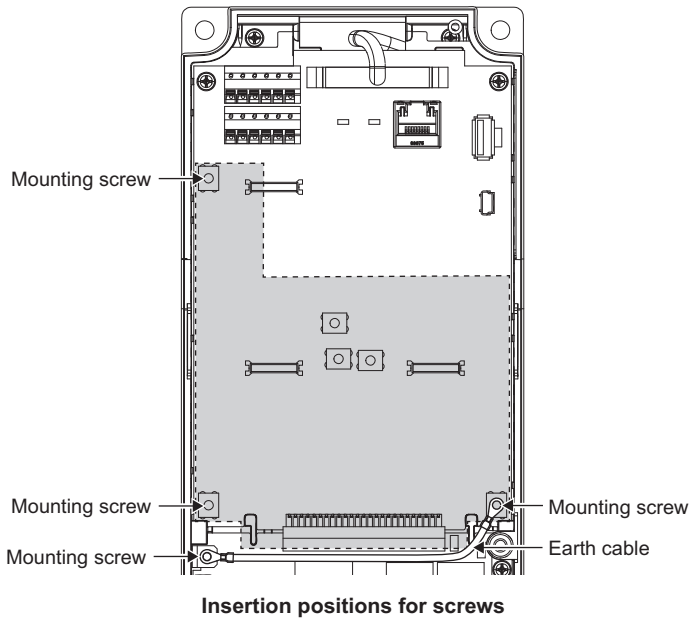

 **NOTE**

- When mounting/removing the plug-in option, hold the sides of the option. Do not press on the parts on the option circuit board. Stress applied to the parts by pressing, etc. may cause a failure.
- Caution must be applied to mounting screws falling off when removing and mounting the plug-in option.
- When using this plug-in option, insert it to the inverter option connector 1. When the inverter cannot recognize that the option is mounted due to improper installation, etc., the protective function (E.1) is activated.
- This plug-in option needs the space for installing three options. Therefore, the other options cannot be used at the same time.
- When removing the plug-in option, remove the three screws, then pull it straight out. Pressure applied to the connector and to the option board may break the option.
- Always attach the earth cable because a malfunction due to noises may occur without it.

2.3 MAC ID (node address) setting

◆ Setting with MAC ID switch

Set the MAC ID between "1 to 99" using MAC ID switches on the FR-A8NCN (refer to [page 8](#)). The setting is reflected when power turns on next or the inverter is reset.

When the MAC ID setting set using [Pr.562](#) is "0", a switch is made valid. (Refer to [page 24](#))

Set the marker of the corresponding switch to the number to set a desired MAC ID.

Use a small flathead screwdriver to set MAC ID switches.

- Setting example

<p>To set the MAC ID to 1: Set the marker of X10 to "0" and the marker of X1 to "1".</p>	<p>To set the MAC ID to "26": Set the marker of X10 to "2" and the marker of X1 to "6".</p>
--	---

NOTE

- Set the inverter MAC ID before switching ON the inverter and do not change the setting while the power is ON. Otherwise you may get an electric shock.
- Set the MAC ID switch to the switch number position correctly. If the switch is set between numbers, normal data communication can not be made.

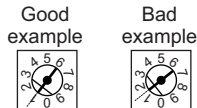

- When the MAC ID switch is set to "00", the inverter is placed in offline status (communication is disabled).
- You cannot set the same MAC ID to other devices on the network. (If different devices have the same node address, the communication cannot be established properly.)

◆ Set with parameter (Pr.562)

Use parameter ([Pr.562](#)) of the inverter to set. Setting MAC ID with parameter makes the MAC ID setting invalid. The setting is reflected at the next power-on or inverter reset. (Refer to [page 24](#))

3.1 Connection to network

- (1) Be sure to check the following before connecting the inverter to the network.
 - Check that the FR-A8NCN is securely inserted into the inverter. (Refer to [page 16.](#))
 - Check that the correct MAC ID is set. (Refer to [page 19.](#))
 - Check that a drop cable is firmly connected to the FR-A8NCN. (Refer to [page 22.](#))
- (2) Make sure that the terminating resistor is installed at each end of the trunk cable. Use the terminating resistor whose resistance value (R) is $75 \Omega \pm 5\%$.
- (3) Connect drop cables to the trunk cable.
 - If the trunk connector is a ControlNet sanctioned pluggable or sealed connector, the connection to the active network can be made at any time whether the inverter is ON or OFF. The option unit automatically detects when the connection is completed.
 - If connecting to the network with free wires, power to the network and inverter should be shut off as a safety precaution in case two or more signal wires are accidentally shorted together.

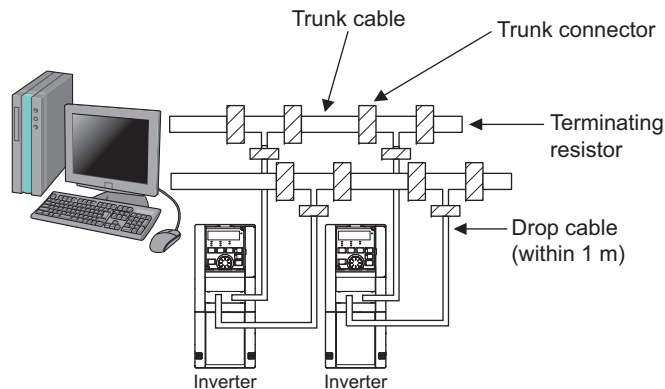

- Total length of trunk cable and drop cable is 1000 m maximum. The length is calculated by the following formula according to the number of inverters connected.

$$\text{Cable length} = 1000 \text{ m} - 16.3 \text{ m} \times (\text{number of inverters connected} - 2)$$

*1 Number of connectable inverters is 2 to 48.

When ten inverters are connected:
 $1000 \text{ m} - 16.3 \text{ m} \times (10 - 2) = 869.6 \text{ m}$

3.2 Wiring

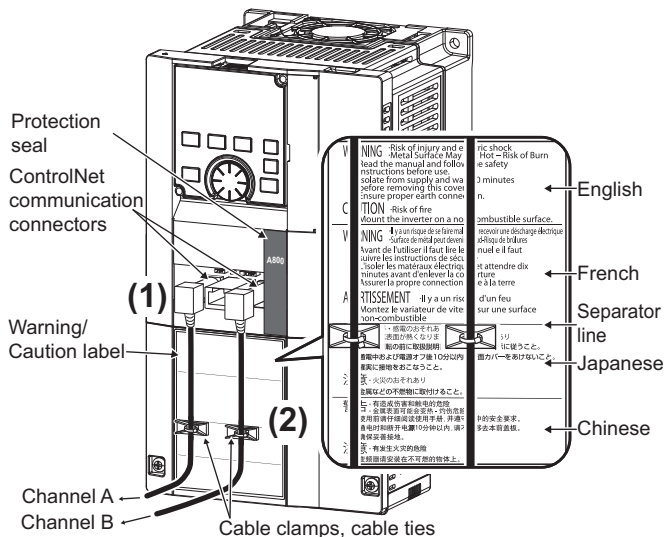

- Connect a ControlNet dedicated cable to the ControlNet communication connector.
 - Recommended items

Item	Type	Maker
Cable	1786-RG6	Rockwell Automation
BNC connector	1786-BNC	
Terminating resistor	1786-XT	
Drop cable	1786-TPR	

- Fix the ControlNet dedicated connecting cables on the front cover of the inverter with the enclosed cable clamps and cable ties. Affix the cable clamps in landscape orientation to the places where the upper side of cable clamps is aligned along with the separator line between the French text and the Japanese text in the warning/caution label, as shown in the left figure. Also, the two ControlNet dedicated connecting cables should drop straight down from the ControlNet connectors.

NOTE

- When wiring cables to the inverter's RS-485 terminals with a plug-in option mounted, take caution not to let the cables touch the circuit board of the option or of the inverter. Otherwise, electromagnetic noises may cause malfunctions.

Caution

- After wiring, wire offcuts must not be left in the inverter. They may cause an error, failure or malfunction.

4 INVERTER SETTING

4.1 Parameter list

The following parameters are used for the communication option (FR-A8NCN).
Set the values according to need.

Pr.	Pr. group	Name	Setting range	Minimum setting increments	Initial value	Refer to page
79	D000	Operation mode selection	0 to 4, 6, 7	1	0	27
338	D010	Communication operation command source	0, 1	1	0	*3
339	D011	Communication speed command source	0, 1, 2	1	0	*3
340*2	D001*2	Communication startup mode selection	0, 1, 2, 10, 12	1	0	27
342	N001	Communication EEPROM write selection	0, 1	1	0	*3
346*1, *2	N201*1, *2	ControlNet baud rate	0 to 4095	1	132	25
349*1	N010*1	Communication reset selection	0, 1	1	0	35
500*1	N011*1	Communication error execution waiting time	0 to 999.8 s	0.1 s	0 s	30
501*1	N012*1	Communication error occurrence count display	0	1	0	31
502	N013	Stop mode selection at communication error	0, 1, 2, 3	1	0	31
550*2	D012*2	NET mode operation command source selection	0, 1, 9999	1	9999	*3
562*1, *2	N230*1, *2	ControlNet data	0 to 4095	1	0	24
779	N014	Operation frequency during communication error	0 to 590 Hz, 9999	0.01 Hz	9999	31

- *1 Parameters which can be displayed when the plug-in option (FR-A8NCN) is mounted.
- *2 The setting is reflected after inverter reset or at the next power-ON.
- *3 Refer to the Instruction Manual (Detailed) of the inverter for the parameter details.

4.2 ControlNet communication parameter

ControlNet communication can be set by the inverter parameter.

4.2.1 ControlNet data (Pr.562)

Pr.	Name	Setting range	Minimum setting increments	Initial value
562	ControlNet data	0 to 4095	1	0

The definition of **Pr.562** is as follows.

15	14	13	12	11	10	9	8	7	6	5	4	3	2	1	0	
Always 0				ResCom	Always 0				MAC ID							

Bit	Item	Initial value	Setting range	Description
0 to 6	Device Node Address (Addr)	0	0	The MAC ID switch setting is made valid (Refer to page 19).
			1 to 99	Node Address (MAC ID) of device is set between 1 to 99.
7 to 10	—	0	—	Set "0" always. (The set value is ignored.)
11	Selection of continuous communication at inverter reset (ResCom)	0	0	Reset the option unit in synchronization with the inverter. When connection is timed out, communication may not resume according to the master action. In this case, release connection and reestablish to make communication enabled.
			1	The option unit will not be reset even if the inverter is reset and communication continues. (Except for after occurrence of "E.1") After inverter reset, preset a value other than "0" in Pr.340 so that the inverter starts in network operation mode.
12 to 15	—	0	0	Set "0" always. (Nonprogrammable)

4.2.2 ControlNet baud rate (Pr.346)

Pr.	Name	Setting range	Minimum setting increments	Initial value
346	ControlNet baud rate	0 to 4095	1	132

Set an I/O communication format for ControlNet communication.

15	14	13	12	11	10	9	8	7	6	5	4	3	2	1	0
Always 0			Input Assembly					Output Assembly					Always 0		

Bit	Item	Initial value	Setting range	Description
0, 1	—	0	—	Set "0" always. (The set value is ignored.)
2 to 6	Output Assembly (OA)	1	0	Output Instance 20 (0x14)
			1	Output Instance 21 (0x15)
			6	Output Instance 126 (0x7E)
			7	Output Instance 129 (0x81)
			Other than the above	Output Instance 21 (0x15)
7 to 11	Input Assembly (IA)	1	0	Input Instance 70 (0x46)
			1	Input Instance 71 (0x47)
			6	Input Instance 176 (0xB0)
			7	Input Instance 179 (0xB3)
			Other than the above	Input Instance 71 (0x47)
12 to 15	—	0	0	Set "0" always. (Nonprogrammable)

- Set the same value for input assembly and output assembly.
- The value can be set with Control Supervisor Class 0x29, Instance 1, Attribute 140, 141 (Refer to [page 63](#)).

Set **Pr.346** according to the output/input instance (number of reception/transmission bytes) of I/O communication as shown in the table below.

Output/input instance (number of reception/transmission bytes)	Pr.346 setting	Output Assembly (Pr.346 Bit2 to Bit6)	Input Assembly (Pr.346 Bit7 to Bit11)
20/70 (4)	0	0	0
21/71 (4)	132 (Initial value)	1	1
126/176 (6)	792	6	6
129/179 (6)	924	7	7

4.3 Operation mode setting

4.3.1 Operation mode switching and communication startup mode (Pr.79, Pr.340)

◆ Operation mode switching conditions

Operation mode switching conditions

- The inverter is at a stop;
- Both the STF and STR signals are off; and
- The **Pr.79 Operation mode selection** setting is correct.
(Set with the operation panel of the inverter.)

◆ Operation mode selection at power ON and at restoration from instantaneous power failure

The operation mode at power ON and at restoration from instantaneous power failure can be selected.

Set a value other than "0" in **Pr.340 Communication startup mode selection** to select the network operation mode.

After started in network operation mode, parameter write from the network is enabled.



- Change of the **Pr.340** setting is valid when powering on or resetting the inverter.
- **Pr.340** can be changed with the operation panel independently of the operation mode.
- Ensure that the communication setting of the inverter is completed before setting **Pr.340** ≠ "0".
- Refer to the Instruction Manual (Detailed) of the inverter for details of **Pr.79, Pr.340**.

Pr.340 setting	Pr.79 setting	Operation mode at power ON or power restoration	Operation mode switchover
0 (initial value)	0 (initial value)	External operation mode	Switching among the External, PU, and NET operation mode is enabled. *1, *4
	1	PU operation mode	PU operation mode fixed
	2	External operation mode	Switching between the External and Net operation mode is enabled. *4 Switching to the PU operation mode is disallowed.
	3, 4	External/PU combined operation mode	Operation mode switching is disallowed.
	6	External operation mode	Switching among the External, PU, and NET operation mode is enabled while running. *4
	7	X12 (MRS) signal ON: external operation mode	Switching among the External, PU, and NET operation mode is enabled. *1, *4
		X12 (MRS) signal OFF: external operation mode	External operation mode fixed (Forcibly switched to External operation mode.)
1, 2 *2	0	NET operation mode	Same as when Pr.340 = "0"
	1	PU operation mode	
	2	NET operation mode	
	3, 4	External/PU combined operation mode	
	6	NET operation mode	
	7	X12 (MRS) signal ON..... NET operation mode	
		X12 (MRS) signal OFF.....external operation mode	

Pr.340 setting	Pr.79 setting	Operation mode at power ON or power restoration	Operation mode switchover
10, 12 *2	0	NET operation mode	Switching between the PU and NET operation mode is enabled. *3, *4
	1	PU operation mode	Same as when Pr.340 = "0"
	2	NET operation mode	NET operation mode fixed
	3, 4	External/PU combined operation mode	Same as when Pr.340 = "0"
	6	NET operation mode	Switching between the PU and NET operation mode is enabled while running. *3, *4
	7	External operation mode	Same as when Pr.340 = "0"

*1 Operation mode can not be directly changed between the PU operation mode and Network operation mode.

*2 The Pr.340 settings "2 or 12" are mainly used for communication operation using the inverter RS-485 terminal.

When a value other than "9999" (selection of automatic restart after instantaneous power failure) is set in Pr.57 **Restart coasting time**, the inverter will resume the same operation state which was in before after power has been restored from an instantaneous power failure.

When Pr.340 = "1 or 10", a start command turns off if power failure has occurred and then restored during a start command is on.

*3 Switching between the PU and NET operation modes is available with the key on the operation panel or the X65 signal.

*4 Refer to [page 67](#) for a switching method from the network.

4.4 Operation at communication error occurrence

4.4.1 Operation selection at communication error occurrence (Pr.500 to Pr.502, Pr.779)

You can select operations at communication error occurrences by setting **Pr.500 to Pr.502, Pr.779** under network operation.

◆ **Waiting time for the communication line error output after a communication error**

Waiting time for the communication error output after a communication line error occurrence can be set.

Pr.	Name	Setting range	Minimum setting increments	Initial value
500	Communication error execution waiting time	0 to 999.8 s	0.1 s	0 s

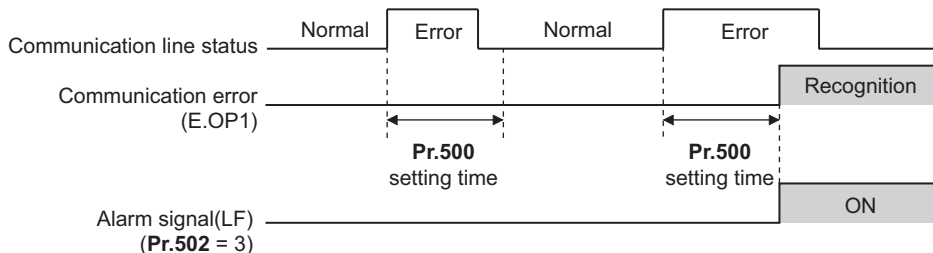

When a communication line error occurs and lasts longer than the time set in **Pr.500**, it is recognized as a communication error. If the communication returns to normal within the time, it is not recognized as a communication error, and the operation continues.

◆ Displaying and clearing the communication error count

The cumulative count of communication error occurrences can be displayed. Write "0" to clear this cumulative count.

Pr.	Name	Setting range	Minimum setting increments	Initial value
501	Communication error occurrence count display	0	1	0

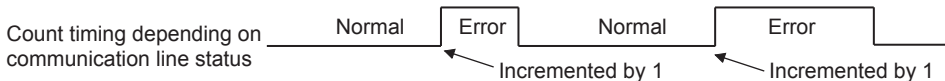

At the point of communication line error occurrence, **Pr.501 Communication error occurrence count display** is incremented by 1.

NOTE

- Communication error count is temporarily stored in the RAM memory. The error count is stored in EEPROM only once per hour. If power reset or converter reset is performed, **Pr.501** setting will be the one that is last stored to EEPROM depending on the reset timing.

◆ Inverter operation at a communication error occurrence

How the inverter operates at a communication line error or an option unit fault can be set.

Pr.	Name	Setting range	Description
502	Stop mode selection at communication error	0 (Initial Value), 1, 2, 3	Refer to page 32 .
779*1	Operation frequency during communication error	0 to 590 Hz	When a communication error occurs, the inverter operates at the set frequency.
		9999 (Initial Value)	The inverter operates at the frequency set before the communication error occurs.

*1 Valid when **Pr.502** = "3".

◆ About setting

- Operation at an error occurrence

Fault description	Pr.502 setting	Operation	Indication	Fault output
Communication line	0	Continued*1	Normal indication*1	Not provided*1
	1			
	2			
	3			
Communication option itself	0, 3	Coast to stop	E. 1 lit	Provided
	1, 2	Decelerated to stop	E. 1 lit after stop	Provided after stop

*1 When the communication returns to normal within the time period set in **Pr.500**, the communication option error (E.OP1) does not occur.

- Operation after the time in **Pr.500** elapses after an error occurrence

Fault description	Pr.502 setting	Operation	Indication	Fault output
Communication line	0	Coast to stop	E.OP1 lit	Provided
	1	Decelerated to stop	E.OP1 lit after stop	Provided after stop
	2			
	3	Continues operation with the Pr.779 setting.	Normal indication	Not provided
Communication option itself	0, 3	Kept stopped*2	E.OP1 kept lit*2	Kept provided*2
	1, 2			

*2 When an error occurs, the motor is decelerated or coasts to stop, and outputs the fault, independently of the **Pr.500** setting.

- Operation at error removal

Fault description	Pr.502 setting	Operation	Indication	Fault output
Communication line	0	Kept stopped	E.OP1 kept lit	Kept provided
	1			
	2	Restart	Normal indication	Not provided
	3	Normal operation		
Communication option itself	0, 3	Kept stopped	E. 1 kept lit	Kept provided
	1, 2			

NOTE

- The protective function [E.OP1 (fault data: HA1)] is activated at error occurrences on the communication line. The protective function [E.1 (fault data: HF1)] is activated at error occurrences in the communication circuit inside the option.
- Fault output indicates the fault (ALM) signal and fault bit output.
- When the fault output setting is active, fault records are stored in the faults history. (A fault record is written to the faults history at a fault output.)
When the fault output setting is not active, fault record is overwritten to the faults history temporarily but not stored. After the error is removed, the fault indication is reset, changing the display back to normal, and the last fault is displayed in the faults history.
- When the **Pr.502** setting is "1 or 2", the deceleration time is the ordinary deceleration time setting (e.g. **Pr.8**, **Pr.44**, **Pr.45**).
- The acceleration time at a restart is the ordinary acceleration time setting (e.g. **Pr.7**, **Pr.44**).
- When the **Pr.502** setting is "2", the operation/speed command at a restart is the one given before the error occurrence.
- When a communication line error occurs at the **Pr.502** setting of "2", removing the error during deceleration causes acceleration to restart at that point. (Acceleration is not restarted if the error is that of the option unit itself.)
- When **Pr.502** = "3", in order to continue the operation in the case of a communication line error, provide a safety stop countermeasure other than via communication. One counter measure is to input a signal to the terminal RES.

4.4.2 Fault and measures

◆ Inverter operation in each operation mode at error occurrences

Location	Status		Operation mode		
			Network operation	External operation	PU operation
Inverter	Inverter operation		Inverter trip	Inverter trip	Inverter trip
	Data communication		Continued	Continued	Continued
Communication line	Inverter operation		Inverter trip *1	Continued	Continued
	Data communication		Stop	Stop	Stop
Communication option	Communication option connection error	Inverter operation	Inverter trip *1	Inverter trip *1	Inverter trip *1
		Data communication	Continued	Continued	Continued
	Error of communication option itself	Inverter operation	Inverter trip *1	Continued	Continued
		Data communication	Stop	Stop	Stop

*1 Depends on the Pr.502 setting.

◆ Measures at error occurrences

Fault indication	Fault description	Measures
E.OP1	Communication line error	<ul style="list-style-type: none"> Check the LED status of the option unit and remove the cause of the alarm (Refer to page 10 for LED indication status). Inspect the master.
E.1	Option fault	<ul style="list-style-type: none"> Insert the communication option to the inverter option connector 1. Check the connection between the inverter and option unit for poor contact, etc. and remove the cause of the error.

*1 When faults other than the above are displayed, refer to the Instruction Manual (Detailed) of the inverter and remove the cause of the error.

4.5 Inverter reset

◆ Operation conditions of inverter reset

Which resetting method is allowed or not allowed in each operation mode is described below.

Resetting method			Operation mode		
			Network operation	External operation	PU operation
Reset from the network	Inverter reset (Class 0x2A, Instance 1, Attribute 101) (Refer to page 67) ^{*1}		Allowed	Disallowed	Disallowed
	Error reset at inverter fault (Refer to page 45, 47, 49, 53, 63) ^{*2}	Pr.349 = 0	Allowed	Allowed	Allowed
		Pr.349 = 1		Disallowed	Disallowed
Turn on the inverter RES signal (terminal RES)			Allowed	Allowed	Allowed
Switch off inverter power			Allowed	Allowed	Allowed
Reset from the PU/ DU	Inverter reset		Allowed	Allowed	Allowed
	Reset at inverter fault		Allowed	Allowed	Allowed

*1 Inverter reset can be made any time.

*2 Reset can be made only when the protective function of the inverter is activated.

NOTE

- When a communication line error has occurred, reset cannot be made from the network.
- The inverter is set to the External operation mode if it has been reset in Network operation mode in the initial status. To resume the network operation, the inverter must be switched to the Network operation mode again. Set a value other than "0" in **Pr.340** to start in the Network operation mode. (Refer to [page 27](#).)
- The inverter can not be controlled for about 1 s after release of a reset command.

◆ Error reset operation selection at inverter fault

An error reset command from communication option can be invalid in the External operation mode or PU operation mode. Use Bit2 of Byte0 of Output Instance 20, 21, 126, or 129 and Class 0x29 Instance 1 Attribute 12 for error reset commands via the network. (Refer to [page 45](#), [47](#), [49](#), [53](#), [63](#).)

Pr.	Name	Initial value	Setting range	Function
349	Communication reset selection	0	0	Error reset is enabled independently of operation mode.
			1	Error reset is enabled only in the network operation mode.

4.6 Frequency and speed settings

- For the output/set frequency monitor, frequency setting, and parameter setting through the FR-A8NCN, the unit of 0.01 Hz is always applied regardless of the **Pr.37 Speed display** setting. The setting unit for the running speed (actual speed) monitor depends on the **Pr.37** and **Pr.144 Speed setting switchover** settings as shown in the following table. (The initial values are shown within the thick lines.)

Pr.37 setting	Pr.144 setting	Output frequency monitor	Set frequency monitor	Running speed (actual speed) monitor	Frequency setting, parameter setting
0 (initial value)	0	0.01 Hz	0.01 Hz	1 r/min *1, *2	0.01 Hz
	2 to 12	0.01 Hz	0.01 Hz	1 r/min *1, *2	0.01 Hz
	102 to 112	0.01 Hz	0.01 Hz	1 r/min *1, *2	0.01 Hz
1 to 9998	0	0.01 Hz	0.01 Hz	1 (machine speed *1)	0.01 Hz
	2 to 12	0.01 Hz	0.01 Hz	1 (machine speed *1)	0.01 Hz
	102 to 112	0.01 Hz	0.01 Hz	1 r/min *1, *2	0.01 Hz

- *1 Running speed r/min conversion formula: frequency × 120 / number of motor poles (**Pr.144**)
Machine speed conversion formula: **Pr.37** × frequency / **Pr.505 Speed setting reference**
For **Pr.144** in the above formula, the value is "**Pr.144** - 100" when "102 to 112" is set in **Pr.144**; and the value is "4" when **Pr.37** = 0 and **Pr.144** = 0.
Pr.505 is always set as frequency (Hz).
- *2 Use **Pr.811 Set resolution switchover** to change the increment from 1 r/min to 0.1 r/min.

- When setting a speed through the FR-A8NCN, the speed is calculated with the **Pr.144** setting as shown below.

$$\text{Speed value (1 r/min *4)} = \text{frequency} \times 120 / \text{number of motor poles (Pr.144 *3)}$$

- *3 When **Pr.144** = "102 to 112," the formula is calculated with the value of (**Pr.144** - 100). When **Pr.144** = "0", the formula is calculated with 4 poles.
- *4 The **Pr.811** setting is invalid. The unit 1 r/min is always applied.

NOTE

- To apply the unit 1 r/min to the running speed (actual speed) monitor, set the initial values in **Pr.37** and **Pr.811**.
- Refer to the Instruction Manual (Detailed) of the inverter for the details of **Pr.37**, **Pr.144**, **Pr.505** and **Pr.811**.

5 FUNCTIONS

5.1 Output from the inverter to the network

Main items to be output from the inverter (FR-A8NCN) to the network and their descriptions are explained below.

Item	Description	Refer to page
Inverter monitor	Monitor various items such as inverter output frequency and output current.	68, 84
Operation mode read	Read the operation mode of the inverter.	67
Parameter read	Read parameter settings of the inverter.	74, 81, 83, 87
Inverter status	Monitor the output signal of the inverter.	67
Fault record	Monitor the faults history of the inverter.	68



- Refer to the Instruction Manual (Detailed) of the inverter for functions controllable from the network in each operation mode.

5.2 Input to the inverter from the network

Main items which can be commanded from the network to the inverter and their descriptions are explained below.

Item	Description	Refer to page
Frequency setting	Set the running frequency of the inverter.	45
Operation mode write	Set the operation mode of the inverter.	67
Run command	Set the control input command such as forward operation signal (STF) and reverse rotation signal (STR).	45, 67
Inverter reset	Reset the inverter.	58, 67
Parameter write	Set parameters of the inverter.	74, 81, 83, 87
Parameter clear	Return parameters to the initial values.	58, 67



- Refer to the Instruction Manual (Detailed) of the inverter for functions controllable from the network in each operation mode.

6 OBJECT MAP DEFINITIONS

6.1 Obejct model of ControlNet

For ControlNet communication, each node is modeled as collections of objects (abstraction of particular functions of the products). The following four terms are used to describe object.

Item	Definition
Class	Collections of all objects which have same types of functions. Generalization of object
Instance	Concrete expression of object
Attribute	Expression of object characteristic
Service	Function supported by object or class

The following explains object definitions for use of the FR-A8NCN ControlNet.

6.2 Data communication type

The FR-A8NCN supports "I/O communication (polling)" and "message communication (Explicit message connection)".

6.2.1 Overview of the I/O communication (polling)

Set Output/Input Instances using either of the following methods.

- Using **Pr.346** (Refer to [page 25](#))
- Using Class 0x29 Instance 1 Attribute 140 or 141 (Refer to [page 63](#))

Instance ID (output/input) *1	No. of bytes of communicated data	Function	Refer to page
20/70	4	The following is available: inverter forward operation and error reset of the inverter.	45
21/71	4	The following is available: inverter forward/reverse operation and error reset of the inverter.	47
126/176	6	The following is available: inverter forward/reverse operation, error reset of the inverter, and access to parameters of the inverter.	49
129/179	6	Inverter forward/reverse operation, error reset, monitor selection, speed command of Hz increments, inverter I/O terminal access, and writing to Pr.496 , etc. can be performed.	53

*1 "Output" is a command to the inverter, and "input" is a response from the inverter.

6.2.2 Overview of the message communication (Explicit message connection)

The data size of parameter writing or reading (Class 0x66, 0x67, 0x70 to 0x79, and 0x90 to 0x94) through the Explicit message is 2 bytes.

Class	Object name	Page
0x01	Identity Object	57
0x04	Assembly Object	59
0x06	Connection Manager Object	60
0x28	Motor Data Object	61
0x29	Control Management Object	62
0x2A	AC Drive Object	65

Class	Object name	Page
0xF0	ControlNet Object	71
0x66	Extended Object I	74
0x67	Extended Object II	81
0x70 to 0x79	Extended Object III	83
0x80	Extended Object IV	84
0x90 to 0x94	Extended Object V	87



- In the following tables, "Get" means reading from the inverter, and "Set" means writing to the inverter.

6.3 Response level

6.3.1 Response level of the I/O communication (polling)

◆ Response level of ControlNet bus

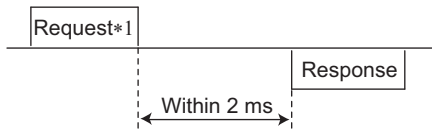

*1 Polling request is accepted only when polling data is changed.

◆ Reflect timing on the actual speed or speed monitor after speed setting

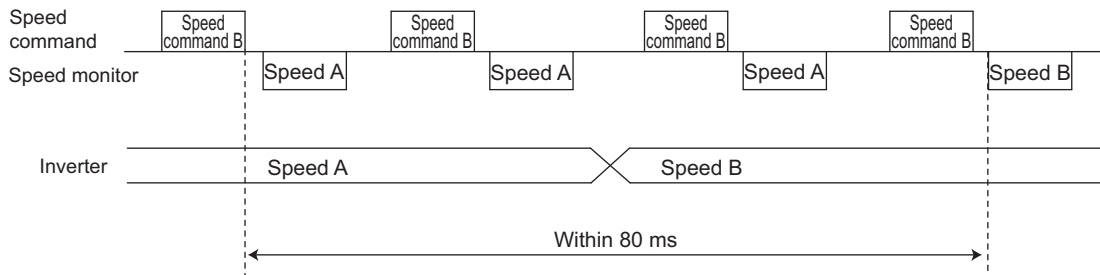

6.3.2 Response level of the message communication (Explicit message connection)

◆ Reading

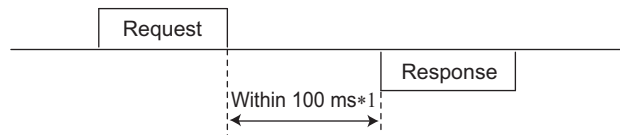

◆ Writing

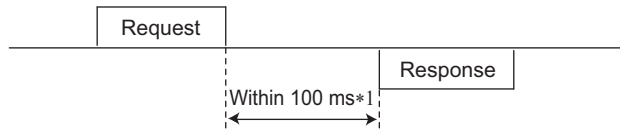

*1 Return "Object state conflict" during processing of 1 command. (Refer to [page 90](#))

◆ Parameter clearing

The inverter will not respond until the parameter clear processing completes (about 5 s) after sending parameter clear or all parameter clear command.

6.4 Recommendation for software developers

Please note the followings when developing software.

- After sending request to the FR-A8NCN, wait for response from the FR-A8NCN, then send the next request.
- Set waiting time between each message based on FR-A8NCN response time on [page 43](#).
For example, after sending a writing request by Explicit message, wait for more than 100 ms, then send the next request.

7 OBJECT MAP

7.1 Format of the I/O communication (polling)

7.1.1 Output Instance 20 / Input Instance 70

◆ Output Instance 20 (master → inverter)

When using Output Instance 20, set Input Instance to 70.

Byte	Bit 7	Bit 6	Bit 5	Bit 4	Bit 3	Bit 2	Bit 1	Bit 0
0	Reserved (0)	Reserved (0)	Reserved (0)	Reserved (0)	Reserved (0)	Fault Reset	Reserved (0)	Run Fwd
1	Reserved (0x00)							
2	Speed reference (low byte)							
3	Speed reference (high byte)							

- Output Instance 20 details

Byte0	Bit0	Run Fwd	Forward rotation signal (0: forward rotation OFF 1: forward rotation ON)
	Bit2	Fault Reset	Reset request at an error occurrence *1 Valid only at in inverter trip (0: no function 1: fault reset request)
Byte2 Byte3		Speed Ref	Speed reference (1 r/min) Conversion of speed and frequency depends on the Pr.144 setting (Refer to page 37).

*1 The communication continues during the error reset of the inverter.

◆ Input Instance 70 (inverter → master)

When using Input Instance 70, set Output Instance to 20.

Byte	Bit 7	Bit 6	Bit 5	Bit 4	Bit 3	Bit 2	Bit 1	Bit 0
0	Reserved (0)	Reserved (0)	Reserved (0)	Reserved (0)	Reserved (0)	Running Fwd	Reserved (0)	Faulted
1	Reserved (0x00)							
2	Speed actual (low byte)							
3	Speed actual (high byte)							

- Input Instance 70 details

Byte0	Bit0	Faulted	Inverter error signal (0: inverter is under normal operation 1: inverter is in a fault state)
	Bit2	Running Fwd	Forward rotation (0: other than forward rotation 1: forward rotation)
Byte2 Byte3	Speed Actual		Inverter running speed (1 r/min increments) Display range: 0 to 32767 The setting values of Pr.37 , Pr.144 , and Pr.811 are effective (Refer to page 37).

7.1.2 Output Instance 21 / Input Instance 71

◆ Output Instance 21 (initial value) (master → inverter)

When using Output Instance 21, set Input Instance to 71.

Byte	Bit 7	Bit 6	Bit 5	Bit 4	Bit 3	Bit 2	Bit 1	Bit 0
0	Reserved (0)	Net Ref	Net Ctrl	Reserved (0)	Reserved (0)	Fault Reset	Run Rev	Run Fwd
1	Reserved (0x00)							
2	Speed reference (low byte)							
3	Speed reference (high byte)							

- Output Instance 21 details

Byte0	Bit0	Run Fwd	Forward rotation signal (0: forward rotation OFF 1: forward rotation ON) *1	Valid only when NetCtrl (Bit5) = "1".
	Bit1	Run Rev	Reverse rotation signal (0: reverse rotation OFF 1: reverse rotation ON) *1	
	Bit2	Fault Reset	Reset request at an error occurrence *2 Valid only at an inverter trip (0: no function 1: fault reset request)	
	Bit5	NetCtrl	0: The values set in Bit0 to 2 of Byte0 are not written to the inverter. 1: The values set in Bit0 to 2 of Byte0 are written to the inverter.	
	Bit6	NetRef	0: The speed reference is not written to the inverter. 1: The speed reference is written to the inverter.	
Byte2 Byte3	Speed Ref		Speed reference (1 r/min) Conversion of speed and frequency depends on the Pr. 144 setting (Refer to page 37). To write the speed reference to the inverter, set NetRef (Bit6 of Byte0) = "1".	

*1 If both Run Fwd and Run Rev are ON, the start signal is not changed. (The previous status remains unchanged.)

*2 The communication continues during the error reset of the inverter.

◆ Input Instance 71 (initial value) (inverter → master)

When using Input Instance 71, set Output Instance to 21.

Byte	Bit 7	Bit 6	Bit 5	Bit 4	Bit 3	Bit 2	Bit 1	Bit 0
0	AtReference	Ref From Net	Ctrl From Net	Ready	Running Rev	Running Fwd	Reserved (0)	Faulted
1	Reserved (0x00)							
2	Speed actual (low byte)							
3	Speed actual (high byte)							

- Input Instance 71 details

Byte0	Bit0	Faulted	Inverter fault signal (0: inverter normal operation 1: inverter fault state)
	Bit2	Running Fwd	Forward rotation (0: other than forward rotation 1: forward rotation)
	Bit3	Running Rev	Reverse rotation (0: other than reverse rotation 1: reverse rotation)
	Bit4	Ready	Ready signal (0: operation preparation 1: operation ready) Always "1" after power ON
	Bit5	CtrlFromNet	0: The inverter is set not to accept the commands Bit0 of Byte0. 1: The inverter is set to accept the commands Bit0 of Byte0.
	Bit6	RefFromNet	0: The inverter is set not to accept the speed commands. 1: The inverter is set to accept the speed commands.
	Bit7	AtReference	Up-to-frequency signal (SU signal) (Same definition with Class 0x2A Instance 1 Attribute 3. Refer to page 65.)
Byte2 Byte3	Speed Actual	Inverter running speed (1 r/min increments) Display range: 0 to 32767 The setting values of Pr.37 , Pr.144 , and Pr.811 are effective (Refer to page 37).	

7.1.3 Output Instance 126 / Input Instance 176

◆ Output instance 126 (master → inverter)

When using Output Instance 126, set Input Instance to 176.

Byte	Bit 7	Bit 6	Bit 5	Bit 4	Bit 3	Bit 2	Bit 1	Bit 0
0	Write Attr	Net Ref	Net Ctrl	Reserved (0)	Reserved (0)	Fault Reset	Run Rev	Run Fwd
1	Parameter Instance ID							
2	Speed reference or parameter write data (low byte)							
3	Speed reference or parameter write data (high byte)							
4	Parameter class ID							
5	Parameter attribute ID							

• Output Instance 126 details

Byte0	Bit0	Run Fwd	Forward rotation signal (0: forward rotation OFF 1: forward rotation ON) *1	Valid only when NetCtrl (Bit5) = "1".
	Bit1	Run Rev	Reverse rotation signal (0: reverse rotation OFF 1: reverse rotation ON) *1	
	Bit2	Fault Reset	Reset request at an error occurrence *2 Valid only at in inverter trip (0: no function 1: fault reset request)	
	Bit5	NetCtrl	0: The values set in Bit0 to 2 of Byte0 are not written to the inverter. 1: The values set in Bit0 to 2 of Byte0 are written to the inverter.	
	Bit6	NetRef *3	0: The speed reference is not written to the inverter. 1: The speed reference is written to the inverter.	
	Bit7	Write Attr *3	0: Byte2 and Byte3 are set to the speed reference. 1: Byte2 and Byte3 are set to the value to be written to the attribute.	

Byte1	Parameter Instance ID	Instance ID can be specified. When 00 is specified, instance ID is regarded as 1.
Byte2 Byte3	Speed Ref or Parameter Write Data	Speed reference (1 r/min) or parameter write data. Selection conditions are determined according to a combination of "NetRef (Bit 6 of Byte 0)" and "Write Attr (Bit 7 of Byte 0)". [When speed reference is selected.] Conversion of speed and frequency depends on the Pr.144 setting (Refer to page 37).
Byte4	Parameter Class ID	Class ID to access to the inverter parameter (class 0x2A, 0x66, 0x67 etc.)
Byte5	Parameter Attribute ID	Attribute ID to access to the inverter parameter

- *1 If both Run Fwd and Run Rev are ON, the start signal is not changed. (The previous status remains unchanged.)
- *2 The communication continues during the error reset of the inverter.
- *3 The following table shows the relation among Write Attr (Bit7 of Byte0), NetRef (Bit6 of Byte0), and Byte1 to Byte5.

Write Attr (Bit7 of Byte0)	NetRef (Bit6 of Byte0)	Byte2, Byte3	Byte4 (Class ID) Byte1 (Instance ID) Byte5 (Attribute ID)
0	0	Speed reference invalid	Specifies the attribute to be read.
0	1	Speed reference valid	
1	0	Value to be written to the attribute	Specifies the attribute to be read or written.
1	1		

◆ Input Instance 176 (inverter → master)

When using Input Instance 176, set Output Instance to 126.

Byte	Bit 7	Bit 6	Bit 5	Bit 4	Bit 3	Bit 2	Bit 1	Bit 0
0	AtReference	Ref From Net	Ctrl From Net	Ready	Running Rev	Running Fwd	Run command mode	Faulted
1	PrEnd	Reserved (0)						
2	Speed actual (low byte)							
3	Speed actual (high byte)							
4	Parameter read data (low byte)							
5	Parameter read data (high byte)							

• Input Instance 176 details

Byte0	Bit0	Faulted	Inverter fault signal (0: inverter normal operation 1: inverter fault state)
	Bit1	Run command mode	0: Command is disabled in network operation. 1: Command is enabled in network operation.
	Bit2	Running Fwd	Forward rotation (0: other than forward rotation 1: forward rotation)
	Bit3	Running Rev	Reverse rotation (0: other than reverse rotation 1: reverse rotation)
	Bit4	Ready	Ready signal (0: operation preparation 1: operation ready) Always "1" after power ON
	Bit5	CtrlFromNet	0: The inverter is set not to accept the commands Bit0 and Bit1 of Byte0. 1: The inverter is set to accept the commands Bit0 and Bit1 of Byte0.
	Bit6	RefFromNet	0: The inverter is set not to accept the speed commands. 1: The inverter is set to accept the speed commands.
	Bit7	AtReference	Up-to-frequency signal (SU signal) (Same definition with Class 0x2A Instance 1 Attribute 3. Refer to page 65 .)

Byte1	Bit7	PrEnd	Parameter write is completed. 0: Parameter write is not performed. 1: During parameter write processing (during inverter processing)
Byte2 Byte3	Speed Actual		Inverter running speed (1 r/min increments) Display range: 0 to 65535 The setting values of Pr.37 , Pr.144 , and Pr.811 are effective (Refer to page 37).
Byte4 Byte5	Parameter Read Data		Parameter read data specified with Parameter Class ID of Instance 126 Parameter Attribute ID (Refer to page 50 .)

*1 Bit status in the run command mode is as follows.
(For the run/ speed command, refer to the Instruction Manual (Detailed) of the inverter.)

Inverter status			Run command mode
Operation mode	Pr.338	Pr.339	
NET	0: NET	0: NET	1
	0: NET	1: External	0
	1: External	0: NET	
	1: External	1: External	
Other than NET	—	—	

7.1.4 Output Instance 129 / Input Instance 179

◆ Output instance 129 (master → inverter)

When using Output Instance 129, set Input Instance to 179.

Byte	Bit 7	Bit 6	Bit 5	Bit 4	Bit 3	Bit 2	Bit 1	Bit 0
0	MRS	NetRef	NetCtrl	Reserved (0)	Reserved (0)	Fault Reset	Run Rev	Run Fwd
1	STOP *4	MRS *4	JOG *4	RH *4	RM *4	RL *4	RT *4	AU *4
2	Frequency reference (low byte)							
3	Frequency reference (high byte)							
4	Monitor selection							
5	Pr.496 write value							

• Output Instance 129 details

Byte0	Bit0	Run Fwd	Forward rotation signal (0: forward rotation OFF 1: forward rotation ON) *1	Valid only when NetCtrl (Bit5) = "1".
	Bit1	Run Rev	Reverse rotation signal (0: reverse rotation OFF 1: reverse rotation ON) *1	
	Bit2	Fault Reset	Reset request at an error occurrence *2 Valid only at in inverter trip (0: no function 1: fault reset request)	
	Bit5	NetCtrl	0: The values set in Bit0 to 2 of Byte0 are not written to the inverter. 1: The values set in Bit0 to 2 of Byte0 are written to the inverter.	
	Bit6	NetRef	0: The speed reference is not written to the inverter. 1: The speed reference is written to the inverter.	
	Bit7	MRS	MRS signal (0: OFF, 1: ON) *3	
Byte1	Various input signal		0: OFF, 1: ON	

Byte2 Byte3	Frequency Ref	Frequency reference (0.01 Hz increments)	Valid only when NetRef (Byte0, Bit6) = "1".
Byte4	Monitor selection	Set an inverter monitor code. The monitor code (monitor item) is the same as that of the RS-485 communication dedicated monitor of the inverter. For the details of the monitor codes or monitor items, refer to the monitor display section in the Instruction Manual (Detailed) of the inverter.	
Byte5	Pr.496 write value	Write to Pr.496 . Write is performed under the condition that the current value and " Pr.496 write value" are different.	

- *1 If both Run Fwd and Run Rev are ON, the start signal is not changed. (The previous status remains unchanged.)
- *2 The communication continues during the error reset of the inverter.
- *3 The signals are fixed. They cannot be changed using parameters.
- *4 Signal names are initial values. Using **Pr.180 to Pr.185**, **Pr.187**, and **Pr.188**, you can change input signal functions. Note that some of signals do not accept a command from the network according to the **Pr.338** and **Pr.339** settings. For example, the RES signal cannot be controlled through the network. Refer to the Instruction Manual (Detailed) of the inverter for details of **Pr.180 to Pr.185**, **Pr.187**, **Pr.188**, **Pr.338**, and **Pr.339**.

◆ Input Instance 179 (inverter → master)

When using Input Instance 179, set Output Instance to 129.

Byte	Bit 7	Bit 6	Bit 5	Bit 4	Bit 3	Bit 2	Bit 1	Bit 0
0	AtReference	Ref From Net	Ctrl From Net	Ready	Running Rev	Running Fwd	Run command mode	Faulted
1	STOP	MRS	JOG	RH	RM	RL	RT	AU
2	Output frequency (low byte)							
3	Output frequency (high byte)							
4	Monitor data (low byte)							
5	Monitor data (high byte)							

• Input Instance 179 details

Byte0	Bit0	Faulted	Inverter error signal (0: inverter is under normal operation 1: inverter is in a fault state)
	Bit1	Run command mode *1	0: Command is disabled in network operation 1: Command is enabled in network operation
	Bit2	Running Fwd	Forward rotation (0: other than forward rotation 1: forward rotation)
	Bit3	Running Rev	Reverse rotation (0: other than reverse rotation 1: reverse rotation)
	Bit4	Ready	Ready signal (0: operation preparation 1: operation ready) (Always "1" after power on)
	Bit5	CtrlFromNet	0: The inverter is set not to accept the commands Bit0 and Bit1 of Byte0. 1: The inverter is set to accept the commands Bit0 and Bit1 of Byte0.
	Bit6	RefFromNet	0: The inverter is set not to accept the speed commands. 1: The inverter is set to accept the speed commands.
	Bit7	AtReference	Up-to-frequency signal (SU signal) (Same definition with Class 0x2A Instance 1 Attribute 3 Refer to page 65)

Byte1	Input terminal monitor	0: OFF 1: ON
Byte2 Byte3	Output frequency	Output frequency (0.01 Hz increments)
Byte4 Byte5	Monitor data	Monitor data specified with "monitor selection" of Instance 129.

*1 Bit status in the run command mode is as follows.
(For the run/ speed command, refer to the Instruction Manual (Detailed) of the inverter.)

Inverter status			Run command mode
Operation mode	Pr.338	Pr.339	
NET	0: NET	0: NET	1
	0: NET	1: External	0
	1: External	0: NET	
	1: External	1: External	
Other than NET	—	—	

7.2 Message communication (Explicit message connection)

7.2.1 Class 0x01 (Identity Object)

◆ Class 0x01 Instance 0

[Attribute]

Class 0x01 Instance 0

Attribute ID	Access	Definition	Data type	No. of data bytes	Attribute value
1	Get	Revision	UINT	2	1
2	Get	Maximum Instance	UINT	2	1

[Service]

Service code	Name	Definition
0x01	Get_Attribute_All	Get all attribute values.

◆ Class 0x01 Instance 1

[Attribute]

Class 0x01 Instance 1

Attribute ID	Access	Definition	Data type	No. of data bytes	Attribute value
1	Get	Vendor ID (Mitsubishi electric)	UINT	2	161
2	Get	Device Type (AC drive)	UINT	2	02
3	Get	Product Code	UINT	2	57
4	Get	Revision	STRUCT	2	1.YYY *1
5	Get	Status	WORD	2	*2
6	Get	Serial Number	UDINT	4	xxxxxxx
7	Get	Product Name (FR-A800)	SHORT_STRING	5	A800 *3

*1 High byte of hexadecimal word data means integer, and low byte means decimal.

For example, when the read data is 0x010A, it means version 1.010.

*2 Bit definition

Bit 0: 0 = allocated, 1 = not allocated, Bit 8: 1 = alarm occurrence, Bit 10: 1 = LED is flickering red, Bit 11: 1 = LED is lit red

*3 The actual data are 0x04, 0x41, 0x38, 0x30, 0x30 when the option is connected to the FR-A800 series.
0x04 means 4 byte data, and the rest means ASCII code of "A800".

[Service]

Service code	Name	Setting range	Description
0x05	Reset *4	0	Inverter reset *5
		1	Inverter reset after all parameter clear *5
0x01	Get_Attribute_All	—	Get all attribute values.

*4 As set in **Pr.75**. Refer to the Instruction Manual (Detailed) of the inverter for details of **Pr.75**.

*5 If the inverter does not accept the command, neither inverter reset nor all parameter clear will be performed.

7.2.2 Class 0x04 (Assembly Object)

[Attribute]

Instance ID	Attribute ID	Access	Name	Data type	No. of data bytes	Description
20	3	Get	Data	BYTE array	4	The data of Output Instance 20 of the I/O communication is returned.
21	3	Get	Data	BYTE array	4	The data of Output Instance 21 of the I/O communication is returned.
126	3	Get	Data	BYTE array	6	The data of Output Instance 126 of the I/O communication is returned.
129	3	Get	Data	BYTE array	6	The data of Output Instance 129 of the I/O communication is returned.
70	3	Get	Data	BYTE array	4	The data of Input Instance 70 of the I/O communication is returned.
71	3	Get	Data	BYTE array	4	The data of Input Instance 71 of the I/O communication is returned.
176	3	Get	Data	BYTE array	6	The data of Input Instance 176 of the I/O communication is returned.
179	3	Get	Data	BYTE array	6	The data of Input Instance 179 of the I/O communication is returned.

[Service]

Service code	Name	Definition
0x0E	Get_Attribute_Single	Get an attribute value.

7.2.3 Class 0x06 (Connection Manager Object)

[Attribute]

Instance attribute is not available.

[Service]

Service code	Name	Definition
0x54	Forward_Open	Open the connection.
0x4E	Forward_Close	Close the connection.

7.2.4 Class 0x28 (Motor Data Object)

◆ Class 0x28 Instance 1

[Attribute]

Class 0x28 Instance 1

Attribute ID	Access	Name	Data type	No. of data bytes	Range	Definition
3	Get	Motor Type	USINT	1	7	Squirrel-cage induction motor
6	Get/Set	Rated Motor Current (Pr. 9)	UINT	2	0 to 0xFFFF	[GET] Return the Pr. 9 setting in 0.1 A increments. (For the FR-A820-03160(55K) or lower, FR-A840-01800(55K) or lower round the value to one decimal place.) [SET] Write the value to Pr. 9 in 0.1 A increments.
7	Get/Set	Rated Voltage (Pr.19)	UINT	2	0 to 0xFFFF	[GET] • When Pr. 19 = "9999" or "8888", return "200" for the 200 V class and "400" for the 400 V class. • When Pr. 19 = "0 to 1000", return the Pr. 19 setting. (Decimal places are rounded.) [SET] Write the setting value ("0 to 1000, 65535 (9999), or 65520 (8888)") to Pr.19 .

[Service]

Service code	Name	Definition
0x0E	Get_Attribute_Single	Get an attribute value.
0x10	Set_Attribute_Single	Set an attribute value.

7.2.5 Class 0x29 (Control Management Object)

◆ Class 0x29 Instance 1

[Attribute]

Class 0x29 Instance 1

Attribute ID	Access	Name	Data type	No. of data bytes	Initial value	Range	Definition	
3	Get/Set	RUN1	BOOL	1	00	0	Forward rotation command OFF	
						1	Forward rotation command ON *1	
4	Get/Set	RUN2	BOOL	1	00	0	Reverse rotation command OFF	
						1	Reverse rotation command ON *1	
5	Get/Set	NetCtrl (operation command source) (Pr.338)	BOOL	1	1	0	Other than ControlNet communication operation (Pr.338 = 1)	Actual state of operation command can be monitored with Attribute 15.
						1	ControlNet communication operation (Pr.338 = 0) *2	
6	Get	State	USINT	1	3	1	Startup	
						2	Not_Ready (during reset)	
						3	Ready (during stop)	
						4	Enabled (during acceleration, during constant speed, during reverse deceleration)	
						5	Stopping (during deceleration)	
						6	Fault_Stop (during deceleration with Pr. 502)	
						7	Faulted (during fault occurrence)	
7	Get	Running1 (forward rotation command)	BOOL	1	0	0	During stop	
						1	During forward rotation	

Class 0x29 Instance 1

Attribute ID	Access	Name	Data type	No. of data bytes	Initial value	Range	Definition
8	Get	Running2 (reverse rotation command)	BOOL	1	0	0	During stop
						1	During reverse rotation
9	Get	Ready	BOOL	1	1	0	During reset or fault occurrence
						1	Stop or running
10	Get	Faulted	BOOL	1	0	0	No fault present
						1	Fault occurred (latched)
12	Get/Set	FaultRst (fault reset) *3, *4	BOOL	1	0	0	Reset release at fault occurrence
						1	Reset execution at fault occurrence
15	Get	CtrlFromNet (operation command source monitor) *5	BOOL	1	1	0	Other than ControlNet communication operation
						1	ControlNet communication operation
140	Get/Set	Instance ID of Input Assembly *6	USINT	1	0x47 (71)	0x46	Input Instance 70
						0x47	Input Instance 71
						0xB0	Input Instance 176
						0xB3	Input Instance 179
141	Get/Set	Instance ID of Output Assembly *7	USINT	1	0x15 (21)	0x14	Output Instance 20
						0x15	Output Instance 21
						0x7E	Output Instance 126
						0x81	Output Instance 129

*1 If both Run1 and Run2 are turned ON, the start signal is not changed. (The previous status remains unchanged.)

*2 The value cannot be written while the inverter is running.

*3 After reset with 01 set, this value must be set to 00 before inverter reset may be performed.

*4 The communication continues during the error reset of the inverter.

*5 This data is only updated after inverter reset or power-ON reset.

*6 When this ID is set, it is reflected to bit 7 to 11 of **Pr.346**.

*7 When this ID is set, it is reflected to bit 2 to 6 of **Pr.346**.

[Service]

Service code	Name	Definition
0x0E	Get_Attribute_Single	Get an attribute value.
0x10	Set_Attribute_Single	Set an attribute value.

7.2.6 Class 0x2A (AC Drive Object)

◆ Class 0x2A Instance 1

[Attribute]

Class 0x2A Instance 1

Attribute ID	Access	Name	Data type	No. of data bytes	Range	Definition
3	Get	AtReference (up to frequency)	BOOL	1	0	Output frequency has not reached the set frequency.
					1	Output frequency has reached the set frequency.
4	Get/Set	NetRef (speed command source) (Pr.339)	BOOL	1	0	Other than ControlNet communication operation (Pr.339 = 1)
					1	ControlNet communication operation (Pr.339 = 0 or 2) *1
Actual state of operation command can be monitored with Attribute 29.						
6	Get	DriveMode (control method)	USINT	1	0	Set "0" always.
7	Get	SpeedActual (actual speed)	INT	2	0 to 32767 r/min	Inverter running speed (1 r/min increments) The setting values of Pr.37, Pr.144, and Pr.811 are effective. (Refer to page 37)
8	Get/Set	SpeedRef (speed setting value)	INT	2	0 to 32767 r/min	Set speed (1 r/min increments) Conversion of frequency and speed depends on the Pr.144 settings. (Refer to page 37)
9	Get	CurrentActual (output current)	INT	2	0 to 3276.7 A	The output current is monitored in 0.1 A increments.
15	Get	PowerActual (output power)	INT	2	0 to 65535 W	Output power is monitored in 1 W increments.

Class 0x2A Instance 1

Attribute ID	Access	Name	Data type	No. of data bytes	Range	Definition
17	Get	OutputVoltage (output voltage)	INT	2	0 to 3276 V	The output voltage is monitored in 0.1 V increments.
18	Get/Set	AccelTime (acceleration time)	UINT	2	0 to 65535 ms	Acceleration time = $\text{Pr.7} \times (\text{Pr.18} / \text{Pr.20})$ Set the increments in ms regardless of the Pr.21 setting.
19	Get/Set	DecelTime (deceleration time)	UINT	2	0 to 65535 ms	Deceleration time = $\text{Pr.8} \times (\text{Pr.18} / \text{Pr.20})$ Set the increments in ms regardless of the Pr.21 setting.
20	Get/Set	LowSpdLimit (minimum frequency) (Pr.2)	UINT	2	0 to 65535 r/min	Minimum speed (1 r/min increments) Conversion of frequency and speed depends on the Pr.144 settings (Refer to page 37).
21	Get/Set	HighSpdLimit (maximum frequency) (Pr.18)	UINT	2	0 to 65535 r/min	Maximum speed (1 r/min increments) Conversion of frequency and speed depends on the Pr.144 settings (Refer to page 37).
29	Get	RefFromNet (speed command source monitor)	BOOL	1	0	Other than ControlNet communication operation
					1	ControlNet communication operation

Class 0x2A Instance 1

Attribute ID	Access	Data type	No. of data bytes	Range	Definition	
101	Set	UINT	2	Any	Inverter reset Set a value other than "0" in Pr. 340 to start in Network operation mode after reset (Refer to page 27). *2	
102	Set	UINT	2	0x965A	Parameter clear *2	
103	Set	UINT	2	0x99AA	All parameter clear *2	
105	Set	UINT	2	0x5A96	Clear parameters *2	Communication parameters are not cleared.
106	Set	UINT	2	0xAA99	All parameter clear *2	
112	Get/Set	UINT	2	0 to 0xE678	Set frequency (RAM) *3	Either write the set frequency to RAM or read from RAM. (0.01 Hz increments)
113	Set	UINT	2	0 to 0xE678	Set frequency (EEPROM) *3	Write the set frequency to EEPROM. (0.01 Hz increments)
114	Get/Set	UINT	2	—	Inverter status monitor/run command (Refer to page 70 .)	
120	Get/Set	UINT	2	0x0000	External operation	Operation mode read (Get)
				0x0001	PU operation	
				0x0002	External JOG operation	
				0x0003	PU JOG operation	
				0x0004	Network operation	
				0x0005	External/PU combined operation	
				0x0010	External operation	Operation mode write (Set) Input 2-byte data.
				0x0011	PU operation (when Pr. 79 = 6)	
0x0014	Network operation					

Class 0x2A Instance 1

Attribute ID	Access	Data type	No. of data bytes	Definition
141	Get/Set	UINT	2	Faults history 1 (latest) Faults history all clear *4
142	Get	UINT	2	Faults history 2 (second fault in past)
143	Get	UINT	2	Faults history 3 (third fault in past)
144	Get	UINT	2	Faults history 4 (fourth fault in past)
145	Get	UINT	2	Faults history 5 (fifth fault in past)
146	Get	UINT	2	Faults history 6 (sixth fault in past)
147	Get	UINT	2	Faults history 7 (seventh fault in past)
148	Get	UINT	2	Faults history 8 (eighth fault in past)
170	Get	UINT	2	Output frequency (0.01 Hz) *8
171	Get	UINT	2	Output current (0.01 A/0.1 A) *5, *8
172	Get	UINT	2	Output voltage (0.1 V) *8
174	Get	UINT	2	Frequency setting value (0.01 Hz)
175	Get	UINT	2	Running speed (1 r/min) The setting values of Pr.37 , Pr.144 , and Pr.811 are effective (Refer to page 37).
176	Get	UINT	2	Motor torque (0.1%)
177	Get	UINT	2	Converter output voltage (0.1 V)
178	Get	UINT	2	Regenerative brake duty (0.1%)
179	Get	UINT	2	Electronic thermal relay function load factor (0.1%)
180	Get	UINT	2	Output current peak value (0.01 A/0.1 A) *5
181	Get	UINT	2	Converter output voltage peak value (0.1 V)
182	Get	UINT	2	Input power (0.01 kW/0.1 kW) *5
183	Get	UINT	2	Output power (0.01 kW/0.1 kW) *5
184	Get	UINT	2	Input terminal status *6

Class 0x2A Instance 1

Attribute ID	Access	Data type	No. of data bytes	Definition
185	Get	UINT	2	Output terminal status *7
186	Get	UINT	2	Load meter
187	Get	UINT	2	Motor excitation current (0.01 A/0.1 A) *5
188	Get	UINT	2	Position pulse
189	Get	UINT	2	Cumulative energization time (1 h)
191	Get	UINT	2	Orientation status
192	Get	UINT	2	Actual operation time (1 h)
193	Get	UINT	2	Motor load factor (0.1%)
194	Get	UINT	2	Cumulative power (1 kWh)
195	Get	UINT	2	Position command (lower digits)
196	Get	UINT	2	Position command (upper digits)
197	Get	UINT	2	Current position (lower digits)
198	Get	UINT	2	Current position (upper digits)
199	Get	UINT	2	Droop pulse (lower digits)

*1 The value cannot be written while the inverter is running.

*2 Error response is returned when the inverter will not accept the same order.

*3 The data written to Attribute 112, 113 can be read from Attribute 112.

*4 Writing any value will clear the fault records.

*5 The setting depends on the inverter capacity.

*6 Input terminal monitor details (when the terminal is ON: 1, when the terminal is OFF: 0, —: undetermined value)

b15

—	—	—	—	CS	RES	STP (STOP)	MRS	JOG	RH	RM	RL	RT	AU	STR	STF
---	---	---	---	----	-----	---------------	-----	-----	----	----	----	----	----	-----	-----

b0

*7 Output terminal monitor details (when the terminal is ON: 1, when the terminal is OFF: 0, —: undetermined value)

b15

—	—	—	—	—	—	—	—	SO	ABC2	ABC1	FU	OL	IPF	SU	RUN
---	---	---	---	---	---	---	---	----	------	------	----	----	-----	----	-----

b0

*8 The monitored values are retained even if an inverter fault occurs. Resetting will clear the retained values.

- Inverter status monitor/bit map of run command

Inverter status (Get)	
bit	Definition
0	RUN (inverter running)
1	FWD (during forward rotation)
2	REV (during reverse rotation)
3	SU (up-to-frequency)
4	OL (overload)
5	IPF (instantaneous power failure)
6	FU (frequency detection)
7	ALM (alarm)
8 to 14	(blank)
15	Operation ready completion (READY)

Run command (Set)			
bit	Definition	bit	Definition
0	(blank)	7	RT (second function selection) *9
1	STF (forward rotation command)	8	AU (current input selection) *9
2	STR (reverse rotation command)	9	CS (selection of automatic restart after instantaneous power failure) *9
3	RH (high-speed operation command) *9	10	MRS (output shutoff) *9
4	RM (middle-speed operation command) *9	11	STOP (start self-holding selection) *9
5	RL (low-speed operation command) *9	12	RES (reset) *9
6	JOG (JOG operation selection) *9	13 to 15	(blank)

*9 Signal names are initial values. Definitions change according to the Pr.180 to Pr.189 (input terminal function selection).

[Service]

Service code	Name	Definition
0x0E	Get_Attribute_Single	Get an attribute value.
0x10	Set_Attribute_Single	Set an attribute value.

7.2.7 Class 0xF0 (ControlNet Object)

◆ Class 0xF0 Instance 1

[Attribute]

Class 0xF0 Instance 1

Attribute ID	Access	Name
0x81	Get	current_link_config
		Link_Config
		NUT_length
		smax
		umax
		slotTime
		blanking
		gb_start
		gb_center
		reserved
		modulus
		gb_prestart
		TUI
		unique_ID
		status_flag
reserved		

Class 0xF0 Instance 1

Attribute ID	Access	Name
0x82	Get/ Get_and_Clear	diagnostic_counters
		buffer_errors
		error_log
		event_counters
		good_frames_transmitted
		good_frames_received
		selected_channel_frame_errors
		channel_A_frame_errors
		channel_B_frame_errors
		aborted_frames_transmitted
		highwaters
		NUT_overloads
		slot_overloads
		blockages
		non_concurrence
		aborted_frames_received
		lonely_counter
		duplicate_node
		noise_hits
		collisions
mod_MAC_ID		
non_lowman_mods		
rogue_count		

Class 0xF0 Instance 1

Attribute ID	Access	Name
0x82	Get/ Get_and_Clear	unheard_moderator
		vendor_specific
		reserved
		vendor_specific
		vendor_specific
		reserved
0x83	Get	station_status
		smac_ver
		vendor_specific
		channel_state
0x84	Get	MAC_ID
		MAC_ID_current
		MAC_ID_switches
		MAC_ID_changed
		Reserved
0x86	Get	error_log
		buffer_errors
		error_log

[Service]

Service code	Name	Definition
0x0E	Get_Attribute_Single	Get an attribute value.
0x4C	Get_And_Clear	Get an attribute value and then clear the diagnostic counters.

7.2.8 Class 0x66 (Extended Object I)

◆ Class 0x66 Instance 1

Set parameters of the inverter. The data type of each attribute is UINT, and the size is 2 bytes. Refer to the Instruction Manual (Detailed) of the inverter for details of the parameters.



- For parameter writing or reading, Class 0x70 to 0x79 (Extended object III) is recommended. (Refer to [page 83](#))

[Attribute]

Class 0x66 Instance 1

Attribute ID	Pr.	Access	Name
10	Pr.0	Get/Set	Torque boost
11	Pr.1	Get/Set	Maximum frequency
12	Pr.2	Get/Set	Minimum frequency
13	Pr.3	Get/Set	Base frequency
14	Pr.4	Get/Set	Multi-speed setting (high speed)
15	Pr.5	Get/Set	Multi-speed setting (middle speed)
16	Pr.6	Get/Set	Multi-speed setting (low speed)
17	Pr.7	Get/Set	Acceleration time
18	Pr.8	Get/Set	Deceleration time
19	Pr.9	Get/Set	Electronic thermal O/L relay
20	Pr.10	Get/Set	DC injection brake operation frequency
21	Pr.11	Get/Set	DC injection brake operation time
22	Pr.12	Get/Set	DC injection brake operation voltage
23	Pr.13	Get/Set	Starting frequency

Class 0x66 Instance 1

Attribute ID	Pr.	Access	Name
24	Pr.14	Get/Set	Load pattern selection
25	Pr.15	Get/Set	Jog frequency
26	Pr.16	Get/Set	Jog acceleration/deceleration time
27	Pr.17	Get/Set	MRS input selection
28	Pr.18	Get/Set	High speed maximum frequency
29	Pr.19	Get/Set	Base frequency voltage
30	Pr.20	Get/Set	Acceleration/deceleration reference frequency
31	Pr.21	Get/Set	Acceleration/deceleration time increments
32	Pr.22	Get/Set	Stall prevention operation level (Torque limit level)
33	Pr.23	Get/Set	Stall prevention operation level compensation factor at double speed
34	Pr.24	Get/Set	Multi-speed setting (speed 4)
35	Pr.25	Get/Set	Multi-speed setting (speed 5)

Class 0x66 Instance 1

Attribute ID	Pr.	Access	Name
36	Pr.26	Get/Set	Multi-speed setting (speed 6)
37	Pr.27	Get/Set	Multi-speed setting (speed 7)
38	Pr.28	Get/Set	Multi-speed input compensation selection
39	Pr.29	Get/Set	Acceleration/deceleration pattern selection
40	Pr.30	Get/Set	Regenerative function selection
41	Pr.31	Get/Set	Frequency jump 1A
42	Pr.32	Get/Set	Frequency jump 1B
43	Pr.33	Get/Set	Frequency jump 2A
44	Pr.34	Get/Set	Frequency jump 2B
45	Pr.35	Get/Set	Frequency jump 3A
46	Pr.36	Get/Set	Frequency jump 3B
47	Pr.37	Get/Set	Speed display
51	Pr.41	Get/Set	Up-to-frequency sensitivity
52	Pr.42	Get/Set	Output frequency detection
53	Pr.43	Get/Set	Output frequency detection for reverse rotation
54	Pr.44	Get/Set	Second acceleration/deceleration time
55	Pr.45	Get/Set	Second deceleration time
56	Pr.46	Get/Set	Second torque boost
57	Pr.47	Get/Set	Second V/F (base frequency)

Class 0x66 Instance 1

Attribute ID	Pr.	Access	Name
58	Pr.48	Get/Set	Second stall prevention operation level
59	Pr.49	Get/Set	Second stall prevention operation frequency
60	Pr.50	Get/Set	Second output frequency detection
61	Pr.51	Get/Set	Second electronic thermal O/L relay
62	Pr.52	Get/Set	Operation panel main monitor selection
64	Pr.54	Get/Set	FM/CA terminal function selection
65	Pr.55	Get/Set	Frequency monitoring reference
66	Pr.56	Get/Set	Current monitoring reference
67	Pr.57	Get/Set	Restart coasting time
68	Pr.58	Get/Set	Restart cushion time
69	Pr.59	Get/Set	Remote function selection
70	Pr.60	Get/Set	Energy saving control selection
71	Pr.61	Get/Set	Reference current
72	Pr.62	Get/Set	Reference value at acceleration
73	Pr.63	Get/Set	Reference value at deceleration
74	Pr.64	Get/Set	Starting frequency for elevator mode
75	Pr.65	Get/Set	Retry selection
76	Pr.66	Get/Set	Stall prevention operation reduction starting frequency

Class 0x66 Instance 1

Attribute ID	Pr.	Access	Name
77	Pr.67	Get/Set	Number of retries at fault occurrence
78	Pr.68	Get/Set	Retry waiting time
79	Pr.69	Get/Set	Retry count display erase
80	Pr.70	Get/Set	Special regenerative brake duty
81	Pr.71	Get/Set	Applied motor
82	Pr.72	Get/Set	PWM frequency selection
83	Pr.73	Get/Set	Analog input selection
84	Pr.74	Get/Set	Input filter time constant
85	Pr.75	Get/Set	Reset selection/disconnected PU detection/PU stop selection
86	Pr.76	Get/Set	Fault code output selection
87	Pr.77	Get	Parameter write selection
88	Pr.78	Get/Set	Reverse rotation prevention selection
89	Pr.79	Get	Operation mode selection
90	Pr.80	Get/Set	Motor capacity
91	Pr.81	Get/Set	Number of motor poles
92	Pr.82	Get/Set	Motor excitation current
93	Pr.83	Get/Set	Rated motor voltage
94	Pr.84	Get/Set	Rated motor frequency
99	Pr.89	Get/Set	Speed control gain (Advanced magnetic flux vector)
100	Pr.90	Get/Set	Motor constant (R1)

Class 0x66 Instance 1

Attribute ID	Pr.	Access	Name
101	Pr.91	Get/Set	Motor constant (R2)
102	Pr.92	Get/Set	Motor constant (L1)/d-axis inductance (Ld)
103	Pr.93	Get/Set	Motor constant (L2)/q-axis inductance (Lq)
104	Pr.94	Get/Set	Motor constant (X)
105	Pr.95	Get/Set	Online auto tuning selection
106	Pr.96	Get/Set	Auto tuning setting/status
110	Pr.100	Get/Set	V/F1 (first frequency)
111	Pr.101	Get/Set	V/F1 (first frequency voltage)
112	Pr.102	Get/Set	V/F2 (second frequency)
113	Pr.103	Get/Set	V/F2 (second frequency voltage)
114	Pr.104	Get/Set	V/F3 (third frequency)
115	Pr.105	Get/Set	V/F3 (third frequency voltage)
116	Pr.106	Get/Set	V/F4 (fourth frequency)
117	Pr.107	Get/Set	V/F4 (fourth frequency voltage)
118	Pr.108	Get/Set	V/F5 (fifth frequency)
119	Pr.109	Get/Set	V/F5 (fifth frequency voltage)
120	Pr.110	Get/Set	Third acceleration/deceleration time
121	Pr.111	Get/Set	Third deceleration time
122	Pr.112	Get/Set	Third torque boost
123	Pr.113	Get/Set	Third V/F (base frequency)

Class 0x66 Instance 1

Attribute ID	Pr.	Access	Name
124	Pr.114	Get/Set	Third stall prevention operation level
125	Pr.115	Get/Set	Third stall prevention operation frequency
126	Pr.116	Get/Set	Third output frequency detection
127	Pr.117	Get/Set	PU communication station number
128	Pr.118	Get/Set	PU communication speed
129	Pr.119	Get/Set	PU communication stop bit length / data length
130	Pr.120	Get/Set	PU communication parity check
131	Pr.121	Get/Set	Number of PU communication retries
132	Pr.122	Get/Set	PU communication check time interval
133	Pr.123	Get/Set	PU communication waiting time setting
134	Pr.124	Get/Set	PU communication CR/LF selection
135	Pr.125	Get/Set	Terminal 2 frequency setting gain frequency
136	Pr.126	Get/Set	Terminal 4 frequency setting gain frequency
137	Pr.127	Get/Set	PID control automatic switchover frequency
138	Pr.128	Get/Set	PID action selection
139	Pr.129	Get/Set	PID proportional band

Class 0x66 Instance 1

Attribute ID	Pr.	Access	Name
140	Pr.130	Get/Set	PID integral time
141	Pr.131	Get/Set	PID upper limit
142	Pr.132	Get/Set	PID lower limit
143	Pr.133	Get/Set	PID action set point
144	Pr.134	Get/Set	PID differential time
145	Pr.135	Get/Set	Electronic bypass sequence selection
146	Pr.136	Get/Set	MC switchover interlock time
147	Pr.137	Get/Set	Start waiting time
148	Pr.138	Get/Set	Bypass selection at a fault
149	Pr.139	Get/Set	Automatic switchover frequency from inverter to bypass operation
150	Pr.140	Get/Set	Backlash acceleration stopping frequency
151	Pr.141	Get/Set	Backlash acceleration stopping time
152	Pr.142	Get/Set	Backlash deceleration stopping frequency
153	Pr.143	Get/Set	Backlash deceleration stopping time
154	Pr.144	Get/Set	Speed setting switchover
155	Pr.145	Get/Set	PU display language selection
157	Pr.147	Get/Set	Acceleration/deceleration time switching frequency
158	Pr.148	Get/Set	Stall prevention level at 0 V input

Class 0x66 Instance 1

Attribute ID	Pr.	Access	Name
159	Pr.149	Get/Set	Stall prevention level at 10 V input
160	Pr.150	Get/Set	Output current detection level
161	Pr.151	Get/Set	Output current detection signal delay time
162	Pr.152	Get/Set	Zero current detection level
163	Pr.153	Get/Set	Zero current detection time
164	Pr.154	Get/Set	Voltage reduction selection during stall prevention operation
165	Pr.155	Get/Set	RT signal function validity condition selection
166	Pr.156	Get/Set	Stall prevention operation selection
167	Pr.157	Get/Set	OL signal output timer
168	Pr.158	Get/Set	AM terminal function selection
169	Pr.159	Get/Set	Automatic switchover frequency range from bypass to inverter operation
170	Pr.160	Get/Set	User group read selection
171	Pr.161	Get/Set	Frequency setting/key lock operation selection
172	Pr.162	Get/Set	Automatic restart after instantaneous power failure selection
173	Pr.163	Get/Set	First cushion time for restart
174	Pr.164	Get/Set	First cushion voltage for restart

Class 0x66 Instance 1

Attribute ID	Pr.	Access	Name
175	Pr.165	Get/Set	Stall prevention operation level for restart
176	Pr.166	Get/Set	Output current detection signal retention time
177	Pr.167	Get/Set	Output current detection operation selection
178	Pr.168	—	Parameter for manufacturer setting (Do not make setting.)
179	Pr.169		
180	Pr.170	Get/Set	Watt-hour meter clear
181	Pr.171	Get/Set	Operation hour meter clear
182	Pr.172	Get/Set	User group registered display/batch clear
183	Pr.173	Get	User group registration
184	Pr.174	Get	User group clear
188	Pr.178	Get/Set	STF terminal function selection
189	Pr.179	Get/Set	STR terminal function selection
190	Pr.180	Get/Set	RL terminal function selection
191	Pr.181	Get/Set	RM terminal function selection
192	Pr.182	Get/Set	RH terminal function selection
193	Pr.183	Get/Set	RT terminal function selection
194	Pr.184	Get/Set	AU terminal function selection
195	Pr.185	Get/Set	JOG terminal function selection
196	Pr.186	Get/Set	CS terminal function selection
197	Pr.187	Get/Set	MRS terminal function selection

Class 0x66 Instance 1

Attribute ID	Pr.	Access	Name
198	Pr.188	Get/Set	STOP terminal function selection
199	Pr.189	Get/Set	RES terminal function selection
200	Pr.190	Get/Set	RUN terminal function selection
201	Pr.191	Get/Set	SU terminal function selection
202	Pr.192	Get/Set	IPF terminal function selection
203	Pr.193	Get/Set	OL terminal function selection
204	Pr.194	Get/Set	FU terminal function selection
205	Pr.195	Get/Set	ABC1 terminal function selection
206	Pr.196	Get/Set	ABC2 terminal function selection
212	Pr.232	Get/Set	Multi-speed setting (speed 8)
213	Pr.233	Get/Set	Multi-speed setting (speed 9)
214	Pr.234	Get/Set	Multi-speed setting (speed 10)
215	Pr.235	Get/Set	Multi-speed setting (speed 11)
216	Pr.236	Get/Set	Multi-speed setting (speed 12)
217	Pr.237	Get/Set	Multi-speed setting (speed 13)
218	Pr.238	Get/Set	Multi-speed setting (speed 14)
219	Pr.239	Get/Set	Multi-speed setting (speed 15)
220	Pr.240	Get/Set	Soft-PWM operation selection
221	Pr.241	Get/Set	Analog input display unit switchover
222	Pr.242	Get/Set	Terminal 1 added compensation amount (terminal 2)
223	Pr.243	Get/Set	Terminal 1 added compensation amount (terminal 4)

Class 0x66 Instance 1

Attribute ID	Pr.	Access	Name
224	Pr.244	Get/Set	Cooling fan operation selection
225	Pr.245	Get/Set	Rated slip
226	Pr.246	Get/Set	Slip compensation time constant
227	Pr.247	Get/Set	Constant-power range slip compensation selection
228	Pr.248	Get/Set	Self power management selection
229	Pr.249	Get/Set	Earth (ground) fault detection at start
230	Pr.250	Get/Set	Stop selection
231	Pr.251	Get/Set	Output phase loss protection selection
232	Pr.252	Get/Set	Override bias
233	Pr.253	Get/Set	Override gain
234	Pr.254	Get/Set	Main circuit power OFF waiting time
235	Pr.255	Get	Life alarm status display
236	Pr.256	Get	Inrush current limit circuit life display
237	Pr.257	Get	Control circuit capacitor life display
238	Pr.258	Get	Main circuit capacitor life display
239	Pr.259	Get	Main circuit capacitor life measuring
240	Pr.260	Get/Set	PWM frequency automatic switchover
241	Pr.261	Get/Set	Power failure stop selection

Class 0x66 Instance 1

Attribute ID	Pr.	Access	Name
242	Pr.262	Get/Set	Subtracted frequency at deceleration start
243	Pr.263	Get/Set	Subtraction starting frequency
244	Pr.264	Get/Set	Power-failure deceleration time 1
245	Pr.265	Get/Set	Power-failure deceleration time 2
246	Pr.266	Get/Set	Power failure deceleration time switchover frequency
247	Pr.267	Get/Set	Terminal 4 input selection
248	Pr.268	Get/Set	Monitor decimal digits selection
249	Pr.269	—	Parameter for manufacturer setting (Do not make setting.)



- Values "8888" and "9999" displayed on the parameter unit indicate 65520 (0xFFFF0) and 65535 (0xFFFF) respectively.

[Service]

Service code	Name	Definition
0x0E	Get_Attribute_Single	Get an attribute value.
0x10	Set_Attribute_Single	Set an attribute value.

7.2.9 Class 0x67 (Extended Object II)

◆ Class 0x67 Instance 1

Set parameters of the inverter. The data type of each attribute is UINT, and the size is 2 bytes.

Refer to the Instruction Manual (Detailed) of the inverter for details of the parameters.



- For parameter writing or reading, Class 0x70 to 0x79 (Extended object III) is recommended. (Refer to [page 83](#))

[Attribute]

Class 0x67 Instance 1

Attribute ID	Pr.	Access	Name
10	Pr.270	Get/Set	Stop-on contact/load torque high-speed frequency control selection
11	Pr.271	Get/Set	High-speed setting maximum current
12	Pr.272	Get/Set	Middle-speed setting minimum current
13	Pr.273	Get/Set	Current averaging range
14	Pr.274	Get/Set	Current averaging filter time constant
15	Pr.275	Get/Set	Stop-on contact excitation current low-speed multiplying factor
16	Pr.276	Get/Set	PWM carrier frequency at stop-on contact
18	Pr.278	Get/Set	Brake opening frequency
19	Pr.279	Get/Set	Brake opening current
20	Pr.280	Get/Set	Brake opening current detection time
21	Pr.281	Get/Set	Brake operation time at start

Class 0x67 Instance 1

Attribute ID	Pr.	Access	Name
22	Pr.282	Get/Set	Brake operation frequency
23	Pr.283	Get/Set	Brake operation time at stop
24	Pr.284	Get/Set	Deceleration detection function selection
25	Pr.285	Get/Set	Overspeed detection frequency (Speed deviation excess detection frequency)
26	Pr.286	Get/Set	Droop gain
27	Pr.287	Get/Set	Droop filter time constant
38	Pr.338	Get/Set	Communication operation command source
39	Pr.339	Get/Set	Communication speed command source
40	Pr.340	Get/Set	Communication startup mode selection
41	Pr.341	Get/Set	RS-485 communication CR/LF selection
42	Pr.342	Get/Set	Communication EEPROM write selection

Class 0x67 Instance 1

Attribute ID	Pr.	Access	Name
45	Pr.345	Get	DeviceNet address
46	Pr.346	Get	ControlNet baud rate
67	Pr.367	Get/Set	Speed feedback range
68	Pr.368	Get/Set	Feedback gain
192	Pr.500	Get/Set	Communication error execution waiting time
193	Pr.501	Get/Set	Communication error occurrence count display
194	Pr.502	Get/Set	Stop mode selection at communication error
202	C2 (Pr.902)	Get/Set	Terminal 2 frequency setting bias frequency
203	C3 (Pr.902)	Get/Set	Terminal 2 frequency setting bias

Class 0x67 Instance 1

Attribute ID	Pr.	Access	Name
204	Pr.125 (Pr.903)	Get/Set	Terminal 2 frequency setting gain frequency
205	C4 (Pr.903)	Get/Set	Terminal 2 frequency setting gain
206	C5 (Pr.904)	Get/Set	Terminal 4 frequency setting bias frequency
207	C6 (Pr.904)	Get/Set	Terminal 4 frequency setting bias
208	Pr.126 (Pr.905)	Get/Set	Terminal 4 frequency setting gain frequency
209	C7 (Pr.905)	Get/Set	Terminal 4 frequency setting gain



- Values "8888" and "9999" displayed on the parameter unit indicate 65520 (0xFFFF0) and 65535 (0xFFFF) respectively.

[Service]

Service code	Name	Definition
0x0E	Get_Attribute_Single	Get an attribute value.
0x10	Set_Attribute_Single	Set an attribute value.

7.2.10 Class 0x70 to 0x79 (Extended Object III)

◆ Class 0x70 to 0x79 Instance 1, 2

Set parameters of the inverter. Refer to the Instruction Manual (Detailed) of the inverter for details of the parameters.

[Attribute]

Class 0x70 to 0x79 Instance 1, 2

Class	Instance	Attribute	Pr.	Access	Data type	Number of bytes	Definition
0x70	1	10 to 109	Pr.0 to Pr.99	Get/Set	UINT	2	
0x71	1	10 to 109	Pr.100 to Pr.199	Get/Set	UINT	2	
0x72	1	10 to 109	Pr.200 to Pr.299	Get/Set	UINT	2	
0x73	1	10 to 109	Pr.300 to Pr.399	Get/Set	UINT	2	
0x74	1	10 to 109	Pr.400 to Pr.499	Get/Set	UINT	2	
0x75	1	10 to 109	Pr.500 to Pr.599	Get/Set	UINT	2	
0x76	1	10 to 109	Pr.600 to Pr.699	Get/Set	UINT	2	
0x77	1	10 to 109	Pr.700 to Pr.799	Get/Set	UINT	2	
0x78	1	10 to 109	Pr.800 to Pr.899	Get/Set	UINT	2	
0x79	1	10 to 109	Pr.900 to Pr.999	Get/Set	UINT	2	Parameter offset for calibration, gain
	2	10 to 49	Pr.900 to Pr.939	Get/Set	UINT	2	Analog value of calibration parameter

[Service]

Service code	Name	Definition
0x0E	Get_Attribute_Single	Get an attribute value.
0x10	Set_Attribute_Single	Set an attribute value.

7.2.11 Class 0x80 (Extended Object IV)

◆ Class 0x80 Instance 1

Inverter monitored value can be read. The data type of each attribute is UINT, and the size is 2 bytes.

Refer to the Instruction Manual (Detailed) of the inverter for the details of each monitor.

[Attribute]

Class 0x80 Instance 1

Attribute ID	Access	Definition	Unit
11	Get	Output frequency *4, *6	0.01 Hz *5
12	Get	Output current *6	0.01 A/0.1 A *1
13	Get	Output voltage *6	0.1 V
15	Get	Frequency setting	0.01 Hz *5
16	Get	Running speed	1 r/min *8
17	Get	Motor torque	0.1%
18	Get	Converter output voltage	0.1 V
19	Get	Regenerative brake duty	0.1%
20	Get	Electronic thermal relay function load factor	0.1%
21	Get	Output current peak value	0.01 A/0.1 A *1
22	Get	Converter output voltage peak value	0.1 V
23	Get	Input power	0.01 kW/0.1 kW *1
24	Get	Output power	0.01 kW/0.1 kW *1
25	Get	Input terminal status *2	—
26	Get	Output terminal status *3	—
27	Get	Load meter	0.1%
28	Get	Motor excitation current	0.01 A/0.1 A *1
29	Get	Position pulse	—

Class 0x80 Instance 1

Attribute ID	Access	Definition	Unit
30	Get	Cumulative energization time	1 h
32	Get	Orientation status	—
33	Get	Actual operation time	1 h
34	Get	Motor load factor	0.1%
35	Get	Cumulative power	1 kWh
36	Get	Position command (lower digits)	1
37	Get	Position command (upper digits)	1
38	Get	Current position (lower digits)	1
39	Get	Current position (upper digits)	1
40	Get	Droop pulse (lower digits)	1
41	Get	Droop pulse (upper digits)	1
42	Get	Torque command	0.1%
43	Get	Torque current command	0.1%
44	Get	Motor output	0.01 kW/0.1 kW *1
45	Get	Feedback pulse	—

Class 0x80 Instance 1

Attribute ID	Access	Definition	Unit
46	Get	Torque monitor (power driving/regenerative driving polarity switching)	0.1%
48	Get	Trace status	1
50	Get	PLC function user monitor 1	According to the SD1215 setting *7
51	Get	PLC function user monitor 2	
52	Get	PLC function user monitor 3	
53	Get	Station Number (RS-485 terminals)	1
54	Get	Station Number (PU)	1
60	Get	Power saving effect	Changeable by parameter setting
61	Get	Cumulative saving power	Changeable by parameter setting
62	Get	PID set point	0.1%
63	Get	PID measured value	0.1%
64	Get	PID deviation	0.1%
71	Get	Motor thermal load factor	0.1%
72	Get	Inverter thermal load factor	0.1%
74	Get	PTC thermistor resistance	0.01 kΩ
77	Get	PID measured value 2	0.1%
83	Get	Cumulative pulse (control terminal option) *9	—

Class 0x80 Instance 1

Attribute ID	Access	Definition	Unit
84	Get	Cumulative pulse overflow times (control terminal option) *9	—
87	Get	32-bit cumulative power (lower 16-bit)	1 kWh
88	Get	32-bit cumulative power (upper 16-bit)	1 kWh
89	Get	32-bit cumulative power (lower 16-bit)	0.01 kWh/0.1 kWh *1
90	Get	32-bit cumulative power (upper 16-bit)	0.01 kWh/0.1 kWh *1
97	Get	Remote output value 1	0.1%
98	Get	Remote output value 2	0.1%
99	Get	Remote output value 3	0.1%
100	Get	Remote output value 4	0.1%
101	Get	PID manipulated amount	0.1%
102	Get	Second PID set point	0.1%
103	Get	Second PID measured value	0.1%
104	Get	Second PID deviation	0.1%
105	Get	Second PID measured value 2	0.1%
106	Get	Second PID manipulated amount	0.1%
107	Get	Dancer main speed setting	0.01 Hz
108	Get	Control circuit temperature	1°C

- *1 The setting depends on the inverter capacity.
- *2 Input terminal monitor details (when the terminal is ON: 1, when the terminal is OFF: 0, —: undetermined value)

b15														b0		
—	—	—	—	CS	RES	STP (STOP)	MRS	JOG	RH	RM	RL	RT	AU	STR	STF	

- *3 Output terminal monitor details (when the terminal is ON: 1, when the terminal is OFF: 0, —: undetermined value)

b15														b0		
—	—	—	—	—	—	—	—	SO	ABC2	ABC1	FU	OL	IPF	SU	RUN	

- *4 When position control is selected, the number of pulses is monitored when **Pr.430** ≠ "9999".
- *5 Regardless of the **Pr. 37** setting, the value is always displayed in frequency (Hz). Refer to the Instruction Manual (Detailed) of the inverter for the details.
- *6 The monitored values are retained even if an inverter fault occurs. Resetting will clear the retained values.
- *7 For the details, refer to the PLC Function Programming Manual.
- *8 The setting values of **Pr.37, Pr.144, and Pr.811** are effective. (Refer to [page 37](#))
- *9 Available when the FR-A8TP is connected.

[Service]

Service code	Name	Definition
0x0E	Get_Attribute_Single	Get an attribute value.

7.2.12 Class 0x90 to 0x94 (Extended Object V)

◆ Class 0x90 to 0x94 Instance 1

Set parameters of the inverter. Refer to the Instruction Manual (Detailed) of the inverter for details of the parameters.

[Attribute]

Class 0x90 to 0x94 Instance 1

Class	Instance	Attribute	Pr.	Access	Data type	Number of bytes	Definition
0x90	1	10 to 109	Pr.1000 to Pr.1099	Get/Set	UINT	2	
0x91	1	10 to 109	Pr.1100 to Pr.1199	Get/Set	UINT	2	
0x92	1	10 to 109	Pr.1200 to Pr.1299	Get/Set	UINT	2	
0x93	1	10 to 109	Pr.1300 to Pr.1399	Get/Set	UINT	2	
0x94	1	10 to 109	Pr.1400 to Pr.1499	Get/Set	UINT	2	

[Service]

Service code	Name	Definition
0x0E	Get_Attribute_Single	Get an attribute value.
0x10	Set_Attribute_Single	Set an attribute value.

8 TROUBLESHOOTING

If a fault occurs and the inverter fails to operate properly, locate the cause of the fault and take proper corrective action by referring to the troubleshooting below. If the corresponding information is not found in the table, the inverter has problem, or the component parts are damaged, contact your sales representative.

Display		Possible causes	Check point	Corrective action
Operation panel of inverter	LED of FR-A8NCN			
E.OP1	Channels A and B Flickering (red)	Connection time-out	<ul style="list-style-type: none"> Master sends messages within time limit. Check for a break in the cable and a disconnected connector. 	<ul style="list-style-type: none"> Shorten the send time interval of master. Check for a cable and connector.
		Duplicate MAC ID	No duplicate MAC ID	After checking required items at left box, reset the inverter and restart the network.
0.00	OFF	<ul style="list-style-type: none"> No good contact between inverter and FR-A8NCN Network power is off. No other node is on the network. 	<ul style="list-style-type: none"> FR-A8NCN is plugged properly. Network power is on. Other nodes are on the network. 	Plug in FR-A8NCN. (Refer to page 16 .) After checking required items at left box, reset the inverter and restart the network.
0.00	ON (red)	Network cable offline	Check that all cables are connected properly.	After checking required items at left box, reset the inverter and restart the network.
E.1	Check that the inverter is not placed in intense vibration environment. Contact your sales representative if any factor other than vibration may cause this alarm.			

Appendix 1 EDS file

Contact your sales representative for details.

Appendix 2 Error Code List

Error code	Name	Definition
0x00	Success	Service was successfully performed by the object specified.
0x02	Resource unavailable	Resources needed for the object to perform the requested service were unavailable.
0x04	Path segment error	The path segment identifier or the segment syntax was not understood by the processing node.
0x05	Path destination unknown	The path referencing an object class and instance or structure element is not known or is not contained in the processing node.
0x07	Connection lost	The messaging connection was lost.
0x08	Service not supported	The requested service was not implemented or was not defined for this Object Class/ Instance.
0x09	Invalid attribute value	The requested service has an error in attribute data.
0x0A	Attribute list error	An attribute in the Get_Attribute_List or Set_Attribute_List response has a non-zero status.
0x0B	Already in requested mode/ state	The object is already in the mode/ state being requested by service.
0x0C	Object state conflict	The object cannot perform the requested service in its current mode/ state.
0x0D	Object already exist	The requested instance of object to be created already exists.
0x0E	Attribute not settable	A request to modify a non-modifiable attribute was received.
0x0F	Privilege violation	A permission/ privilege check failed
0x10	Device state conflict	The device's current mode/ state prohibits the execution of the requested service.
0x11	Reply data too large	The data to be transmitted in the response buffer is larger than the allocated response buffer.
0x13	Not enough data	The service did not supply enough data to perform the specified.
0x14	Attribute not supported	The attribute specified in the request is not supported.
0x15	Too much data	The service supplied more data than was expected.

Error code	Name	Definition
0x16	Object does not exist	The object specified does not exist in the device.
0x18	No stored attribute data	The attribute data of this object was not saved prior to the requested service.
0x19	Store operation failure	The attribute data of this object was not saved due to a failure during the attempt.
0x1C	Missing attribute list entry data	The service did not supply an attribute in a list of attributes that was needed by service to perform the requested behaviour.
0x1D	Invalid attribute value list	The service is returning the list of attributes supplied with status information for those attributes that was invalid.
0x1F	Vender specific error	A vender specific error has been encountered.
0x20	Invalid parameter	A parameter associated with the request was invalid.
0x27	Unexpected attribute in list	An attempt was made to set an attribute that is not able to be set at this time.
0x28	Invalid Member ID	The Member ID specified in the request does not exist in the specified Class/ Instance/ Attribute.
0x29	Member not settable	A request to modify a non-modifiable attribute was received.
0x2A	Group 2 only server general failure	This error code may only be reported by group 2 only servers with 4K or less code space and only in place of Service not supported, Attribute not supported and Attribute not settable.

REVISIONS

*The manual number is given on the bottom left of the back cover.

Print Date	*Manual Number	Revision
May 2015	IB(NA)-0600570ENG-A	First edition

INVERTER

mitsubishi **MITSUBISHI ELECTRIC CORPORATION**

HEAD OFFICE: TOKYO BUILDING 2-7-3, MARUNOUCHI, CHIYODA-KU, TOKYO 100-8310, JAPAN