

RH-FH Series

Industrial robots

Intelligent solutions

for complex manufacturing processes



0.29 s 12" cycle time enables high-precision, high-performance applications to be used to increase on-site productivity



Fitted with many interfaces such as Ethernet, USB, camera interface, additional axis controller, hand I/O etc. as standard



Fitted with many interfaces such as Ethernet, USB, camera interface, additional axis controller, hand I/O etc. as standard



Fitted with many interfaces such as Ethernet, USB, camera interface, additional axis controller, hand I/O etc. as standard

More productivity and efficiency



Speed and easy integration allow wide-ranging applications.

The fastest in their class

The robots of the RH-F series achieve the highest speeds in their class thanks to the new motors developed by Mitsubishi Electric, high arm rigidity and unique control technology. The resulting reduced cycle time of only 0.29 seconds for a 12" cycle make for significantly increased productivity and improved continuous operation.

The dramatically extended movement range ensures more flexibility and thus simplifies system planning. Effective access to the entire, almost circular working range has many advantages: it reduces cycle times by avoiding unnecessary movements and increases the tasks which the robot can perform in its working range.

Easy integration and application

It makes no difference whether you are modernising your manufacturing system or setting it up for the first time. Straight from the factory, the RH-F series offers many features which are only available as optional extras on comparable products. For example, every model has connections for pneumatic grippers, Ethernet, USB, tracking functions, camera interface, hand I/O, additional axis controller and an interface for GOT HMI's with freely programmable user interfaces. The standard grease is food-grade H1 grease – ideal for the food and beverage industry. An ISO Level III clean-room model is also available for pharmaceutical and microelectronics applications.

Even the RH-3FH entry-level model is equally well equipped, and with a load capacity of 3 kg is suitable for most applications. Anyone requiring to move heavier loads can call upon the top-of-the-range RH-6/20FH with a maximum load capacity of 20 kg. The RH-6/12/20FH has the tried-and-tested protection class IP54 for industrial systems which protects against dust and spray water. For use in particularly contaminated or dusty environments, the model can be retrospectively upgraded to IP65 at relatively little cost and without any problems thanks to the closed housing concept.



The RH-F series is supported by high-performance controllers.

Forward-looking, fascinating and flexible

When it comes to their modern production systems, companies are placing increasing importance on high production speeds and efficient integration into existing systems as well as a full range of connection options. Characteristics which are easily fulfilled by the Mitsubishi Electric RH-F series in a forward-looking, flexible and fascinating manner.

Mitsubishi Electric SCARA robots are used wherever maximum precision is required. The innovative Mitsubishi Electric MELFA robots are known for their wide-ranging applications, whether for fast palletising, accurate sorting or parts assembly. The RH-F series also confirms this approach. These SCARA robots are suitable for a variety of industrial applications straight from the factory and without the need to purchase additional modules.

Wide-ranging applications

The RH-F series is a range of robust, high-quality robots with an outstanding price/performance ratio. They are suitable straight from the factory for a wide range of industrial applications and can be deployed in many industries. Examples include industrial sectors such as food and beverage, packaging, laboratory automation, automobile manufacturing and cell manufacturing. In addition, MELFA RH-F robots can be easily and cost-effectively adapted to suit most requirements and situations.

More safety

When several robots are used in one work cell, a CPU connection between the controllers ensures that individual robots are controlled in a co-ordinated manner. They can be operated individually as easily as in normal operation.

In jog or automatic mode, an anti-collision function ensures that robots are stopped in good time before they can collide, thus preventing damage. This avoids additional expensive working time for carrying out repairs following a collision due to incorrect position information or wrongly set interlocks.

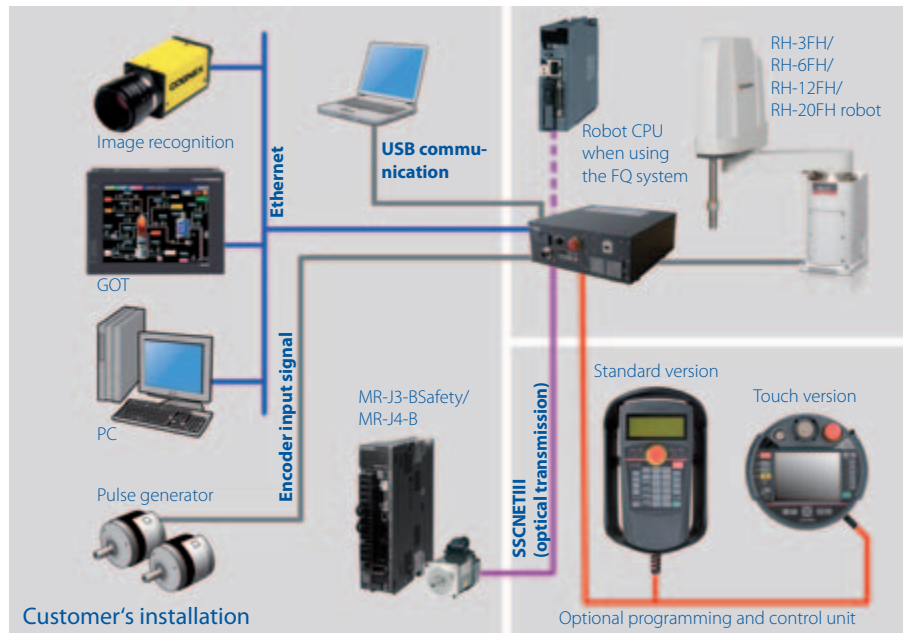

Standard robot control interfaces

Advanced programming

A further advantage is the quick and easy commissioning via PC. Models of the RH-F series can be quickly and easily programmed using the supplied RT ToolBox2 software.

The RT ToolBox2 programming software's graphical interface enables imported 3D CAD files, program variables and robot simulations to be displayed quickly and easily.

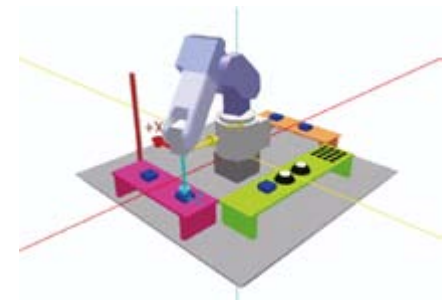

Simulation with CAD data

Movement range and dimensions

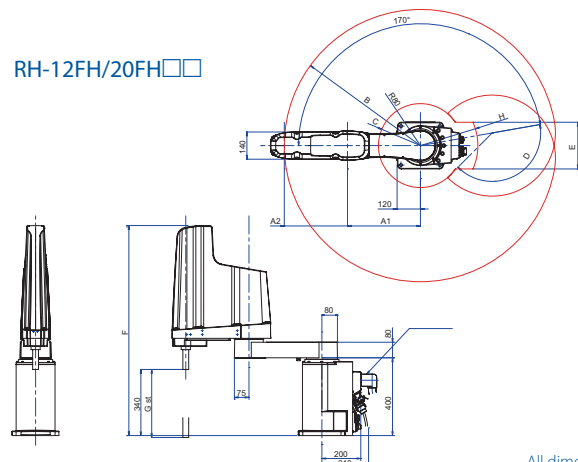
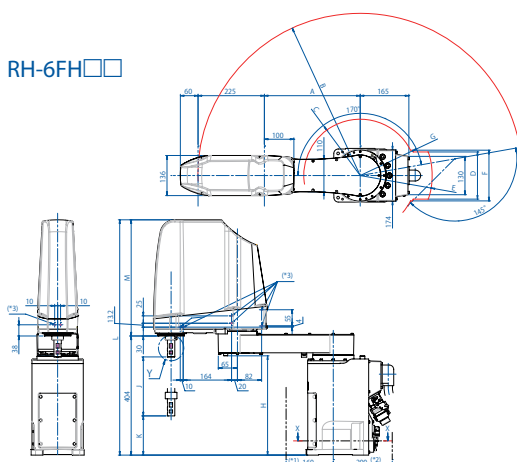

All dimensions in mm

Dimensions for type	A	A1	A2	B	C	D	E	F	G	H	J	K	L	M
RH-6FH5520-S15	325	—	—	R550	R191	160	R244	172	R197	337	200	133	798	386
RH-12FH/20FH8535-S15	—	525	325	R850	R278	153°	—	1080/1180	350/450	—	—	—	—	—

The shown data in the table are only an extract of all data about standard reach arms.

Specifications

Robot		RH-3FH 5515-S15	RH-6FH 5520-S15	RH-12FH 8535N-S15	RH-20FH 8535N-S15	
Installation		Floor mounting				
Degrees of freedom		4				
Design		Horizontal articulated arm (SCARA)				
Drive system		AC servo motor				
Position detection method		Absolute encoder				
Arm length	Arm 1	mm	325	525		
	Arm 2	mm	225	325		
Max. working range (Arm 1 + Arm 2)		mm	550	850		
Maximum speed	J1-axis	deg/s	420	400	250	
	J2-axis	deg/s	720	670	450	
	J3(Z)-axis	mm/s	1100	2400	2800	2400
	J4(θ)-axis	deg/s	3000	2500	2400	1700
Maximum composite speed		mm/s	8300		11350	11372
Cycle time (with 2 kg load)		s	0.41	0.29	0.30	
Lifting capacity	Nominal	kg	1	3	3	5
	Maximum	kg	3	6	12	20
Repeat accuracy	X-,Y-direction	mm	±0.012		±0.015	
	J3(Z)-axis	mm	±0.010			
	J4(θ)-axis	deg	±0.004		±0.005	
Operating temperature		°C	0–40			
Weight		kg	32	37	69	75
Tool wiring		Hand: 8 inputs/8 outputs (20 pins total) Serial signal cable for parallel I/O (2-pin and 2 pins for power supply) LAN 100BASE-TX (RJ45)				
Tool pneumatic pipes		Primary: Ø6 x 2, Secondary: Ø4 x 8				
Protection class		IP20	IP54 (IP65 optional)			
Compatible robot controller*		CR750-D/Q				

* Select the control unit suitable for your application.
CR750-D: Stand-alone unit, CR750-Q: Unit for incorporating in iQ Platform.

Robot controller		CR750-Q	CR750-D
Programming language		MELFA-BASIC V	
Position determination		Teaching, manual data input (MDI)	
	General-purpose I/O	up to 8192	up to 256
	Dedicated I/O	Common I/O for multiple CPU	User-defined
External I/O	Gripper status signal inputs	8 inputs	
	External emergency stop	1 (redundant)	
	Door closed contact	1 (redundant)	
	Enabling switch	1 (redundant)	
	Emergency stop additional axes	1 (redundant)	
RS422		1 (Teaching Box)	
Interfaces	Ethernet	1 (Teaching Box)	1 (Teaching Box) 1 (spare) 10BASE-T/100BASE-TX
	USB	1 (USB port for PLC CPU)	1 (Mini-B connector, Ver. 2.0)
	Additional axis	up to 8 (SSCNETIII)	
	Conveyor belt tracking encoder	Q173DPX (optional)	2
	Expansion slot	—	2
Power supply	Input voltage	Single phase 180 V to 253 V AC ①	
	Power consumption kVA ②	2.0	
Ambient temperature	°C	0–40 (drive unit)/ 0–55 (robot CPU)	0–40
Dimensions (WxHxD)	mm	430x425x174	
Weight	kg	approx. 20	
Housing/protection class		Floor mounting/IP20	

① The supply voltage should not vary by more than 10%.
② Without switch-on current.



Version check