

# MITSUBISHI



**iQ** Platform Supporting Engineering Environment

MELSOFT **iQ** Works

---

**Beginner's Manual**

---

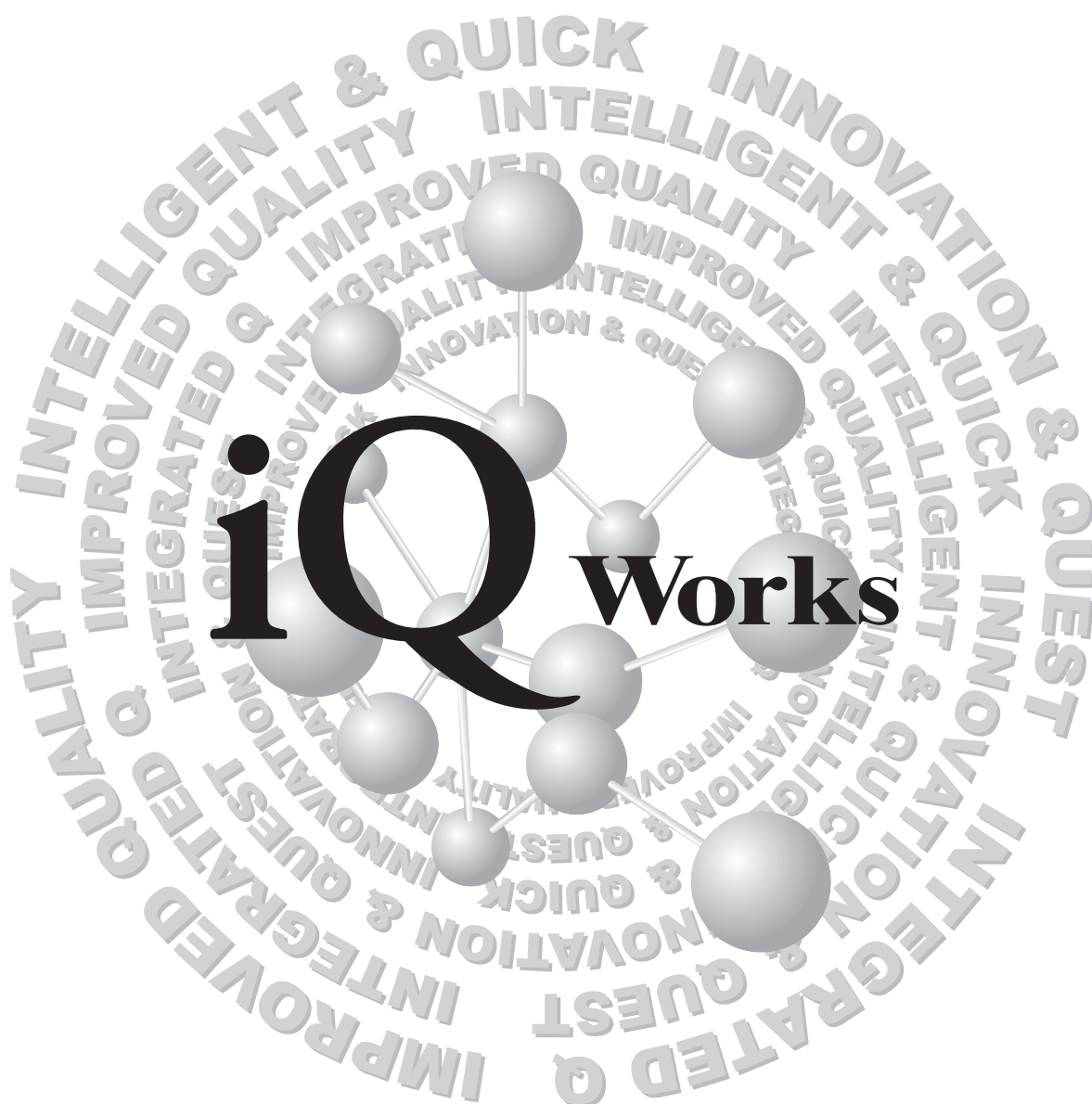

**MELSOFT**  
**Integrated FA Software**

SW1DND-IQWK-E(DVD-ROM)  
SW1DNC-IQWK-E(CD-ROM)



# ● SAFETY PRECAUTIONS ●

(Always read these instructions before using this product.)

Before using this product, thoroughly read this manual and the relevant manuals introduced in this manual and pay careful attention to safety and handle the products properly.

The precautions given in this manual are concerned with this product. For the safety precautions of the system, refer to the User's Manual for each controller.

In this manual, the safety precautions are ranked as "⚠ WARNING" and "⚠ CAUTION".



Indicates that incorrect handling may cause hazardous conditions, resulting in death or severe injury.



Indicates that incorrect handling may cause hazardous conditions, resulting in minor or moderate injury or property damage.

Note that the ⚠ CAUTION level may lead to serious consequences according to the circumstances. Always follow the precautions of both levels because they are important for personal safety.

Please save this manual to make it accessible when required and always forward it to the end user.

## [Design Instructions]

### ⚠ WARNING

- When data change, program change, or status control is performed from a personal computer to a running controller, create an interlock circuit outside the programmable controller to ensure that the whole system always operates safely. Furthermore, for the online operations performed from a personal computer to a controller, the corrective actions against a communication error due to such as a cable connection fault should be predetermined as a system.

## [Startup/Maintenance Instructions]

### ⚠ CAUTION

- The online operations performed from a personal computer to a running controller (Program change, operating status change such as RUN-STOP switching, and remote control operation) have to be executed after the manual has been carefully read and the safety has been ensured. When changing a program while a controller is RUN, it may cause a program corruption in some operating conditions. Fully understand the precautions described in the manuals and Help function of each controller before use.

# ● CONDITIONS OF USE FOR THE PRODUCT ●

- (1) Mitsubishi programmable controller ("the PRODUCT") shall be used in conditions;
- i) where any problem, fault or failure occurring in the PRODUCT, if any, shall not lead to any major or serious accident; and
  - ii) where the backup and fail-safe function are systematically or automatically provided outside of the PRODUCT for the case of any problem, fault or failure occurring in the PRODUCT.

- (2) The PRODUCT has been designed and manufactured for the purpose of being used in general industries.

MITSUBISHI SHALL HAVE NO RESPONSIBILITY OR LIABILITY (INCLUDING, BUT NOT LIMITED TO ANY AND ALL RESPONSIBILITY OR LIABILITY BASED ON CONTRACT, WARRANTY, TORT, PRODUCT LIABILITY) FOR ANY INJURY OR DEATH TO PERSONS OR LOSS OR DAMAGE TO PROPERTY CAUSED BY the PRODUCT THAT ARE OPERATED OR USED IN APPLICATION NOT INTENDED OR EXCLUDED BY INSTRUCTIONS, PRECAUTIONS, OR WARNING CONTAINED IN MITSUBISHI'S USER, INSTRUCTION AND/OR SAFETY MANUALS, TECHNICAL BULLETINS AND GUIDELINES FOR the PRODUCT.

("Prohibited Application")

Prohibited Applications include, but not limited to, the use of the PRODUCT in;

- Nuclear Power Plants and any other power plants operated by Power companies, and/or any other cases in which the public could be affected if any problem or fault occurs in the PRODUCT.
- Railway companies or Public service purposes, and/or any other cases in which establishment of a special quality assurance system is required by the Purchaser or End User.
- Aircraft or Aerospace, Medical applications, Train equipment, transport equipment such as Elevator and Escalator, Incineration and Fuel devices, Vehicles, Manned transportation, Equipment for Recreation and Amusement, and Safety devices, handling of Nuclear or Hazardous Materials or Chemicals, Mining and Drilling, and/or other applications where there is a significant risk of injury to the public or property.

Notwithstanding the above, restrictions Mitsubishi may in its sole discretion, authorize use of the PRODUCT in one or more of the Prohibited Applications, provided that the usage of the PRODUCT is limited only for the specific applications agreed to by Mitsubishi and provided further that no special quality assurance or fail-safe, redundant or other safety features which exceed the general specifications of the PRODUCTS are required. For details, please contact the Mitsubishi representative in your region.

REVISIONS

The manual number is written at the bottom left of the back cover.

Print date	Manual number	Revision
Oct., 2009	SH-080902ENG-A	First edition
Apr., 2010	SH-080902ENG-B	<p><b>Model Addition</b> MELSEC-L series</p> <p><b>Addition</b> CONDITIONS OF USE FOR THE PRODUCT, Section 3.4, Section 3.10</p> <p><b>Correction</b> MANUALS, GENERIC TERMS AND ABBREVIATIONS IN THIS MANUAL, Section 1.1, Section 1.2, Section 2.1, Section 3.3, Section 3.4, Section 3.5, Section 3.6, Section 3.7, Section 3.8, Section 3.9, Section 3.10, Section 3.12, Section 4.1, Section 4.2, Section 4.3, Section 4.4, Section 5.1, Section 5.2, Section 6.2</p>
Sep., 2010	SH-080902ENG-C	<p><b>Model Addition</b> MELSEC-FX series</p> <p><b>Addition</b> Section 3.4, Section 3.10</p> <p><b>Correction</b> GENERIC TERMS AND ABBREVIATIONS IN THIS MANUAL, Section 1.1, Section 1.2, Section 2.1, Section 3.1, Section 3.3, Section 3.4, Section 3.5, Section 3.6, Section 3.7, Section 3.8, Section 3.9, Section 3.11, Section 3.13, Section 4.1, Section 4.2, Section 4.3, Section 4.4, Section 5.1, Section 5.2, Section 6.2</p>
Apr., 2011	SH-080902ENG-D	<p><b>Addition</b> GENERIC TERMS AND ABBREVIATIONS IN THIS MANUAL</p> <p><b>Correction</b> HOW TO READ THIS MANUAL, Section 1.1, Section 1.2, Section 2.1, Section 3.1, Section 3.3, Section 3.4, Section 3.5, Section 3.6, Section 3.7, Section 3.8, Section 4.1, Section 4.2, Section 4.4, Section 5.1, Section 5.2, Section 6.2</p>
Nov., 2011	SH-080902ENG-E	<p><b>Addition</b> MANUALS, GENERIC TERMS AND ABBREVIATIONS IN THIS MANUAL, Section 3.4.4</p> <p><b>Correction</b> Section 1.1, Section 1.2, Section 2.1, Section 3.1, Section 3.2, Section 3.3, Section 3.4, Section 3.5, Section 3.8, Section 3.9, Section 3.11, Section 3.13, Section 4.1, Section 4.2, Section 4.3, Section 4.4, Section 5.2, Section 6.1, Section 6.2</p>
Jun., 2012	SH-080902ENG-F	<p><b>Correction</b> Section 1.1, Section 1.2, Section 2.1, Section 3.4, Section 3.5, Section 3.8, Section 4.1, Section 4.2, Section 4.3, Section 4.4, Section 6.2</p>
Nov., 2012	SH-080902ENG-G	<p><b>Correction</b> Section 1.2, Section 3.2, Section 3.4, Section 3.11, Section 5.2</p>

Print date	Manual number	Revision
Jun., 2013	SH-080902ENG-H	<p data-bbox="547 277 651 306"><b>Addition</b></p> <p data-bbox="547 311 692 338">Section 3.4.5</p> <p data-bbox="547 344 671 374"><b>Correction</b></p> <p data-bbox="547 378 1123 405">Section 2.1, Section 3.4.1, Section 3.4.4, Section 3.11</p>
Dec., 2013	SH-080902ENG-I	<p data-bbox="547 439 651 468"><b>Addition</b></p> <p data-bbox="547 472 845 499">Section 3.4.6, Section 3.4.7</p> <p data-bbox="547 506 671 535"><b>Correction</b></p> <p data-bbox="547 539 1428 624">MANUALS, GENERIC TERMS AND ABBREVIATIONS IN THIS MANUAL, Section 3.4.2, Section 3.4.3, Section 3.4.4, Section 3.5.1, Section 3.6, Section 3.7, Section 3.9, Section 3.11, Section 5.2</p>

Japanese Manual Version SH-080763-J

This manual confers no industrial property rights or any rights of any other kind, nor does it confer any patent licenses. Mitsubishi Electric Corporation cannot be held responsible for any problems involving industrial property rights which may occur as a result of using the contents noted in this manual.

# INTRODUCTION

---

Thank you for purchasing the Mitsubishi integrated FA software, MELSOFT series.  
Before using the product, thoroughly read this manual to develop full familiarity with the functions and performance to ensure correct use.

## CONTENTS

---

SAFETY PRECAUTIONS .....	A - 1
REVISIONS .....	A - 3
INTRODUCTION .....	A - 5
CONTENTS .....	A - 5
MANUALS.....	A - 7
HOW TO READ THIS MANUAL .....	A - 11
GENERIC TERMS AND ABBREVIATIONS IN THIS MANUAL.....	A - 13
<b>1 OVERVIEW</b> .....	<b>1 - 1 to 1 - 10</b>
<hr/>	
1.1 MELSOFT iQ Works .....	1 - 2
1.2 Features .....	1 - 3
<hr/>	
<b>2 SCREEN CONFIGURATION</b> .....	<b>2 - 1 to 2 - 4</b>
<hr/>	
2.1 Screen Configuration .....	2 - 2
<hr/>	
<b>3 OPERATING PROCEDURE OF MELSOFT NAVIGATOR</b> .....	<b>3 - 1 to 3 - 60</b>
<hr/>	
3.1 Procedure of MELSOFT Navigator from Start to End .....	3 - 2
3.2 Starting MELSOFT Navigator .....	3 - 3
3.3 Creating Workspaces .....	3 - 4
3.4 Creating System Configuration Diagram .....	3 - 8
3.4.1 System configuration to be created .....	3 - 8
3.4.2 Creating module configuration diagrams.....	3 - 9
3.4.3 Creating network configuration diagrams.....	3 - 20
3.4.4 Creating CC-Link configuration diagrams.....	3 - 22
3.4.5 Creating AnyWireASLINK configuration diagrams .....	3 - 24
3.4.6 Creating Ethernet configuration diagrams .....	3 - 26
3.4.7 Creating CC IE Field configuration diagrams .....	3 - 28
3.5 Creating Projects .....	3 - 30
3.5.1 Creating new projects.....	3 - 30
3.5.2 Allocating projects to controllers.....	3 - 35
3.6 Setting Parameters .....	3 - 38
3.7 Checking System Configuration .....	3 - 47
<hr/>	

3.7.1	Checking system configuration .....	3 - 47
3.7.2	Checking power supply capacity and I/O points .....	3 - 48
<b>3.8</b>	<b>Editing Projects</b>	<b>3 - 49</b>
3.8.1	Editing projects.....	3 - 49
3.8.2	Utilizing existing projects (import) .....	3 - 50
<b>3.9</b>	<b>Reading/Writing/Verifying Controller Data</b>	<b>3 - 53</b>
<b>3.10</b>	<b>Saving Workspaces</b>	<b>3 - 56</b>
3.10.1	Saving workspaces with specified names.....	3 - 56
3.10.2	Overwriting workspaces .....	3 - 57
<b>3.11</b>	<b>Printing Workspaces</b>	<b>3 - 58</b>
<b>3.12</b>	<b>Closing Workspaces</b>	<b>3 - 59</b>
<b>3.13</b>	<b>Exiting MELSOFT Navigator</b>	<b>3 - 60</b>

---

## 4 USING SYSTEM LABELS 4 - 1 to 4 - 20

<b>4.1</b>	<b>Registering System Labels in MELSOFT Navigator</b>	<b>4 - 2</b>
4.1.1	Registering system labels in MELSOFT Navigator .....	4 - 3
4.1.2	Assigning devices to system labels.....	4 - 5
4.1.3	Using system labels in GT Designer3 .....	4 - 8
<b>4.2</b>	<b>Utilizing Existing Labels as System Labels</b>	<b>4 - 11</b>
4.2.1	Registering labels as system labels .....	4 - 12
4.2.2	Using system labels in motion controller projects .....	4 - 15
<b>4.3</b>	<b>Using System Labels on another personal computer</b>	<b>4 - 17</b>
<b>4.4</b>	<b>Checking System Labels</b>	<b>4 - 19</b>

---

## 5 CREATING SYSTEM BACKUP DATA 5 - 1 to 5 - 6

<b>5.1</b>	<b>Setting Batch Read Password</b>	<b>5 - 2</b>
<b>5.2</b>	<b>Executing Batch Read Function</b>	<b>5 - 4</b>

---

## 6 USING PROGRAM JUMP FUNCTION 6 - 1 to 6 - 5

<b>6.1</b>	<b>Example of System Configuration</b>	<b>6 - 2</b>
<b>6.2</b>	<b>Program Jump Function</b>	<b>6 - 3</b>



## ■ MANUALS

---

The manuals related to this product are shown below.  
Refer to the following tables when ordering required manuals.

### Related manuals

- 1) MELSOFT Navigator  
For details of operations, refer to the Help function of MELSOFT Navigator.
- 2) GX Works2

Manual name	Manual number (Model code)
GX Works2 Version 1 Operating Manual (Common) Explains the system configuration of GX Works2 and the functions common to a Simple project and Structured project such as parameter setting, operation method for the online function. (Sold separately)	SH-080779ENG (13JU63)
GX Works2 Version 1 Operating Manual (Simple Project) Explains operation methods such as creating and monitoring programs in Simple project of GX Works2. (Sold separately)	SH-080780ENG (13JU64)
GX Works2 Version 1 Operating Manual (Structured Project) Explains operation methods such as creating and monitoring programs in Structured project of GX Works2. (Sold separately)	SH-080781ENG (13JU65)
GX Works2 Beginner's Manual (Simple Project) Explains fundamental operation methods such as creating, editing, and monitoring programs in Simple project for users inexperienced with GX Works2. (Sold separately)	SH-080787ENG (13JZ22)
GX Works2 Beginner's Manual (Structured Project) Explains fundamental operation methods such as creating, editing, and monitoring programs in Structured project for users inexperienced with GX Works2. (Sold separately)	SH-080788ENG (13JZ23)

### 3) GT Designer3

Manual name	Manual number (Model code)
GT Designer3 Version 1 Screen Design Manual (Fundamentals) Explains the system configuration, screen configuration, basic operations for dialog boxes, methods such as creating new project and transferring data to GOT, and convenient screen editing operations of GT Designer3. (Sold separately)	SH-080866ENG (1D7MB9)
GT Designer3 Version 1 Screen Design Manual (Functions) (1/2, 2/2) Explains common settings, object function specifications, setting methods, and arranging methods of GT Designer3. (Sold separately)	SH-080867ENG (1D7MC1)
GT Designer3 (GOT2000) Screen Design Manual Explains the system configuration, screen configuration, basic operations for dialog boxes, methods such as creating new project and transferring data to GOT, and convenient screen editing operations of GT Designer3. (Sold separately)	SH-081220ENG (1D7ML9)
GOT1000 Series Connection Manual (Mitsubishi Products) for GT Works3 Explains Mitsubishi products that can be connected to GOT and their connection method. (Sold separately)	SH-080868ENG (1D7MC2)
GOT1000 Series Connection Manual (Non-Mitsubishi Products 1) for GT Works3 Explains non-Mitsubishi products that can be connected to GOT and their connection method. (Sold separately)	SH-080869ENG (1D7MC3)
GOT1000 Series Connection Manual (Non-Mitsubishi Products 2) for GT Works3 Explains non-Mitsubishi products that can be connected to GOT and their connection method. (Sold separately)	SH-080870ENG (1D7MC4)
GOT1000 Series Connection Manual (Microcomputer, MODBUS Products, Peripherals) for GT Works3 Explains the connection method between GOT and peripherals such as a bar code reader. (Sold separately)	SH-080871ENG (1D7MC5)
GOT2000 Series Connection Manual (Mitsubishi Product) For GT Works3 Version1 Explains Mitsubishi products that can be connected to GOT and their connection method. (Sold separately)	SH-081197ENG (1D7MJ8)
GOT2000 Series Connection Manual (Non Mitsubishi Product 1) For GT Works3 Version1 Explains non-Mitsubishi products that can be connected to GOT and their connection method. (Sold separately)	SH-081198ENG (1D7MJ9)
GOT2000 Series Connection Manual (Non Mitsubishi Product 2) For GT Works3 Version1 Explains non-Mitsubishi products that can be connected to GOT and their connection method. (Sold separately)	SH-081199ENG (1D7MK1)
GOT2000 Series Connection Manual (Microcomputer, MODBUS Products, Peripherals) For GT Works3 Version1 Explains the connection method between GOT and peripherals such as a bar code reader. (Sold separately)	SH-081200ENG (1D7MK2)
GT Simulator3 Version 1 Operating Manual Explains the system configuration, screen configuration, and operation methods of GT Simulator3 used in GOT1000 series (GT16/GT15/GT11) and GOT-A900 series. (Sold separately)	SH-080861ENG (1D7MB1)
GT SoftGOT1000 Version 3 Operating Manual for GT Works3 Explains the system configuration, screen configuration, and operation methods of monitoring software GT Soft GOT1000. (Sold separately)	SH-080860ENG (1D7MA9)
GT SoftGOT2000 Version1 Operating Manual Explains the system configuration, screen configuration, and operation methods of monitoring software GT Soft GOT2000. (Sold separately)	SH-081201ENG (1D7MK3)

### 4) MT Developer2

Refer to the Help function of MT Developer2.

## 5) Motion Controllers

Manual name	Manual number (Model code)
Q173DCPU/Q172DCPU Motion controller Programming Manual (COMMON) Explains the Multiple CPU system configuration, performance specifications, common parameters, auxiliary/applied functions, and error lists. (Optional)	IB-0300134 (1XB928)
Q173DCPU/Q172DCPU Motion controller (SV13/SV22) Programming Manual (Motion SFC) Explains the functions, programming, debugging, and error lists of Motion SFC. (Optional)	IB-0300135 (1XB929)
Q173DCPU/Q172DCPU Motion controller (SV13/SV22) Programming Manual (REAL MODE) Explains the servo parameters, positioning instructions, device lists, and error lists. (Optional)	IB-0300136 (1XB930)
Q173DCPU/Q172DCPU Motion controller (SV22) Programming Manual (VIRTUAL MODE) Explains the dedicated instructions, servo parameters, positioning instructions for mechanical system program comprised of a virtual main shaft or mechanical module required to execute the synchronous control, device lists, and error lists. (Optional)	IB-0300137 (1XB931)
Q173HCPU/Q172HCPU Motion controller Programming Manual (COMMON) Explains the Multiple CPU system configuration, performance specifications, common parameters, auxiliary/applied functions and error lists. (Optional)	IB-0300111 (1XB911)
Q173HCPU/Q172HCPU Motion controller (SV13/SV22) Programming Manual (Motion SFC) Explains the functions, programming, debugging, and error lists of Motion SFC. (Optional)	IB-0300112 (1XB912)
Q173HCPU/Q172HCPU Motion controller (SV13/SV22) Programming Manual (REAL MODE) Explains the servo parameters, positioning instructions, device list, and error lists. (Optional)	IB-0300113 (1XB913)
Q173HCPU/Q172HCPU Motion controller (SV22) Programming Manual (VIRTUAL MODE) Explains the dedicated instructions, servo parameters, positioning instructions for mechanical system program comprised of a virtual main shaft or mechanical module required to execute the synchronous control, device lists, and error lists. (Optional)	IB-0300114 (1XB914)
Q173HCPU/Q172HCPU Motion controller (SV43) Programming Manual Explains the dedicated instructions to execute the positioning control by Motion program of EIA language (G-code), servo parameters, positioning instructions, device list, and error lists. (Optional)	IB-0300115 (1XB915)
Q173CPU(N)/Q172CPU(N) Motion controller (SV13/SV22) Programming Manual (Motion SFC) Explains the Multiple CPU system configuration, performance specifications, functions, programming, and error codes of the Motion SFC. (Optional)	IB-0300042 (1XB781)
Q173CPU(N)/Q172CPU(N) Motion controller (SV13/SV22) Programming Manual (REAL MODE) Explains the servo parameters, positioning instructions, device list, and error lists. (Optional)	IB-0300043 (1XB782)
Q173CPU(N)/Q172CPU(N) Motion controller (SV22) Programming Manual (VIRTUAL MODE) Explains the dedicated instructions, servo parameters, positioning instructions for mechanical system program comprised of a virtual main shaft or mechanical module required to execute the synchronous control, device lists, and error lists. (Optional)	IB-0300044 (1XB783)
Q173CPU(N)/Q172CPU(N) Motion controller (SV43) Programming Manual Explains the dedicated instructions to execute the positioning control by Motion program of EIA language (G-code), Multiple CPU system configuration, performance specifications, functions, programming, debugging, servo parameters, positioning instructions, device list, and error lists. (Optional)	IB-0300070 (1CT784)

## 6) RT ToolBox2

Manual name	Manual number (Model code)
CR750/700/500 series RT ToolBox2 / RT ToolBox2 mini User's Manual Explains operation methods such as creating and monitoring programs, and connecting with robots.	BFP-A8618

### Point

The Operating Manual is included on the DVD-ROM/CD-ROM of the software package in PDF file format. Manuals in printed form are sold separately for single purchase. Order a manual by quoting the manual number (model code) listed in the table above.

● **Purpose of this manual**

This manual explains the features and operations of iQ Platform supporting engineering environment MELSOFT iQ Works.

Manuals and the Help function for reference are listed in the following table according to their purpose.

For information such as the contents and number of each manual, refer to the list of 'Related manuals'.

Purpose	Manuals and HELP function for reference
Creating GX Works2 projects	GX Works2 Version 1 Operating Manual (Common) GX Works2 Version 1 Operating Manual (Simple Project) GX Works2 Version 1 Operating Manual (Structured Project) GX Works2 Beginner's Manual (Simple Project) GX Works2 Beginner's Manual (Structured Project)
Creating MT Developer2 projects	Help function of MT Developer2
Creating GT Designer3 projects	GT Designer3 Version 1 Screen Design Manual (For GOT 1000 Series) GT Designer3 (GOT2000) Screen Design Manual
Creating RT ToolBox2 projects	CR750/700/500 series RT ToolBox2 / RT ToolBox2 mini User's Manual
Using system labels	GX Works2 Version 1 Operating Manual (Common) GX Works2 Version 1 Operating Manual (Simple Project) GX Works2 Version 1 Operating Manual (Structured Project)
Using data backup function	GX Works2 Beginner's Manual (Simple Project) GX Works2 Beginner's Manual (Structured Project) Help function of MT Developer2
Using program jump function	Motion controller programming manual of Q173D/Q172D, Q173H/Q172H, Q173/Q172

## ■ HOW TO READ THIS MANUAL

---

This section explains how to read this manual according to your purpose when using MELSOFT iQ Works.

Please use this manual with referring to the following descriptions.

- 1) To learn about the overview of MELSOFT iQ Works

 Chapter 1 OVERVIEW

Chapter 1 explains the features of MELSOFT iQ Works.

- 2) To learn about the screen configuration of MELSOFT iQ Works

 Chapter 2 SCREEN CONFIGURATION

Chapter 2 explains the screen configuration of MELSOFT Navigator.

- 3) To learn about the operating procedures of MELSOFT Navigator

 Chapter 3 OPERATING PROCEDURE OF MELSOFT NAVIGATOR

Chapter 3 explains a sequence of the basic operation from start-up to creating and saving methods of workspaces and projects.

- 4) To learn about the system labels

 Chapter 4 USING SYSTEM LABELS

Chapter 4 explains the functions to utilize labels used in a project for controller projects in a workspace.

- 5) To learn about the data backup

 Chapter 5 CREATING SYSTEM BACKUP DATA

Chapter 5 explains the functions to read programmable controller projects, motion controller projects, and GOT projects from respective controllers in batch and create their backup data using MELSOFT Navigator.

- 6) To learn about the program jump function

 Chapter 6 USING PROGRAM JUMP FUNCTION





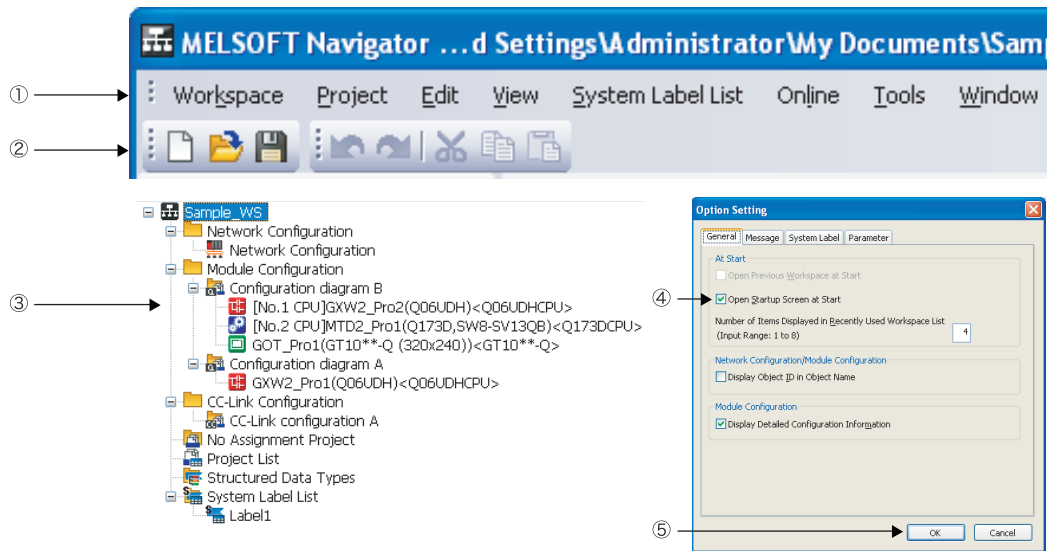

Chapter 6 explains the function which can start motion SFC programs/servo programs, that are linked with motion controller programs, using the SFCS and SVST instructions of ladder programs.

This explains notes requiring attention or useful functions relating to the information given on the same page.

● Symbols used in this manual

The following shows the symbols used in this manual with descriptions and examples.



No.	Symbol	Description	Example
①	[ ]	Menu name on a menu bar	[Workspace]
②		Toolbar icon	
③	" "	Item name in a workspace	"Configuration diagram B"
④	" "	Item name in a screen	"Open Startup Screen at Start"
⑤		Button on a screen	
-		Keyboard key	

## ■ GENERIC TERMS AND ABBREVIATIONS IN THIS MANUAL

This manual uses the generic terms and abbreviations listed in the following table to discuss the software packages and programmable controller CPUs. Corresponding module models are also listed if needed.

Generic term and abbreviation	Description
MELSOFT Navigator	Generic product name of the integrated development environment for SWnDND-IQWK-E/ SWnDNC-IQWK-E (iQ Platform supporting engineering environment MELSOFT iQ Works) (n: version)
GX Works2	Generic product name for SWnDNC-GXW2-E (n: version) MELSOFT Navigator compatible GX Works2 is GX Works2Version 1.15R or later.
MT Developer2	Generic product name for SWnDNC-MTW2-E (n: version) MELSOFT Navigator compatible MT Developer2 is MT Developer2 Version 1.09K or later.
GT Designer3	Generic product name for SWnD5C-GTWK3-E (n: version) MELSOFT Navigator compatible GT Designer3 is GT Designer3 Version 1.05F or later.
GX Developer	Generic product name for SWnD5C-GPPW-E (n: version) MELSOFT Navigator compatible GX Developer is GX Developer Version 8.95Z or later.
RT ToolBox2	Generic product name for 3D-11C-WINE/3D-12C-WINE MELSOFT Navigator compatible RT ToolBox2 is RT ToolBox2 Version 2.00A or later.
Q series	Generic term for MELSEC-Q series
L series	Generic term for MELSEC-L series
FX series	Generic term for MELSEC-F series
Controller	Generic terms for programmable controller, motion controller, and GOT
Network	Generic terms for CC-Link IE controller network, MELSECNET/H, and Ethernet
Personal computer	Generic term for personal computers on which Windows® operates
GOT	Generic term for Mitsubishi Graphic Operation Terminal GOT1000 series and GOT2000 Series
System configuration diagram	Generic terms for network configuration and module configuration
GX Works2 project	Projects that created/saved with GX Works2 (GX Works2 format project)
GX Developer project	Projects that created/saved with GX Developer (GX Developer format project)







# 1 OVERVIEW

This chapter explains the features of MELSOFT iQ Works.

1.1	MELSOFT iQ Works.....	1-2
1.2	Features .....	1-3

1	OVERVIEW
2	SCREEN CONFIGURATION
3	OPERATING PROCEDURE OF MELSOFT NAVIGATOR
4	USING SYSTEM LABELS
5	CREATING SYSTEM BACKUP DATA
6	USING PROGRAM JUMP FUNCTION

## 1.1 MELSOFT iQ Works

MELSOFT iQ Works is an integrated engineering software product which includes GX Works2, MT Developer2, GT Designer3, and RT ToolBox2.

While sharing design information such as system designs and programming in the whole control system, the system designing efficiency and the programming efficiency are improved, and thus the total programming cost is reduced.

This manual explains the system management method using MELSOFT Navigator.

Q series, L series, and FX series are supported in MELSOFT Navigator, however, this manual explains the operations of Q series.

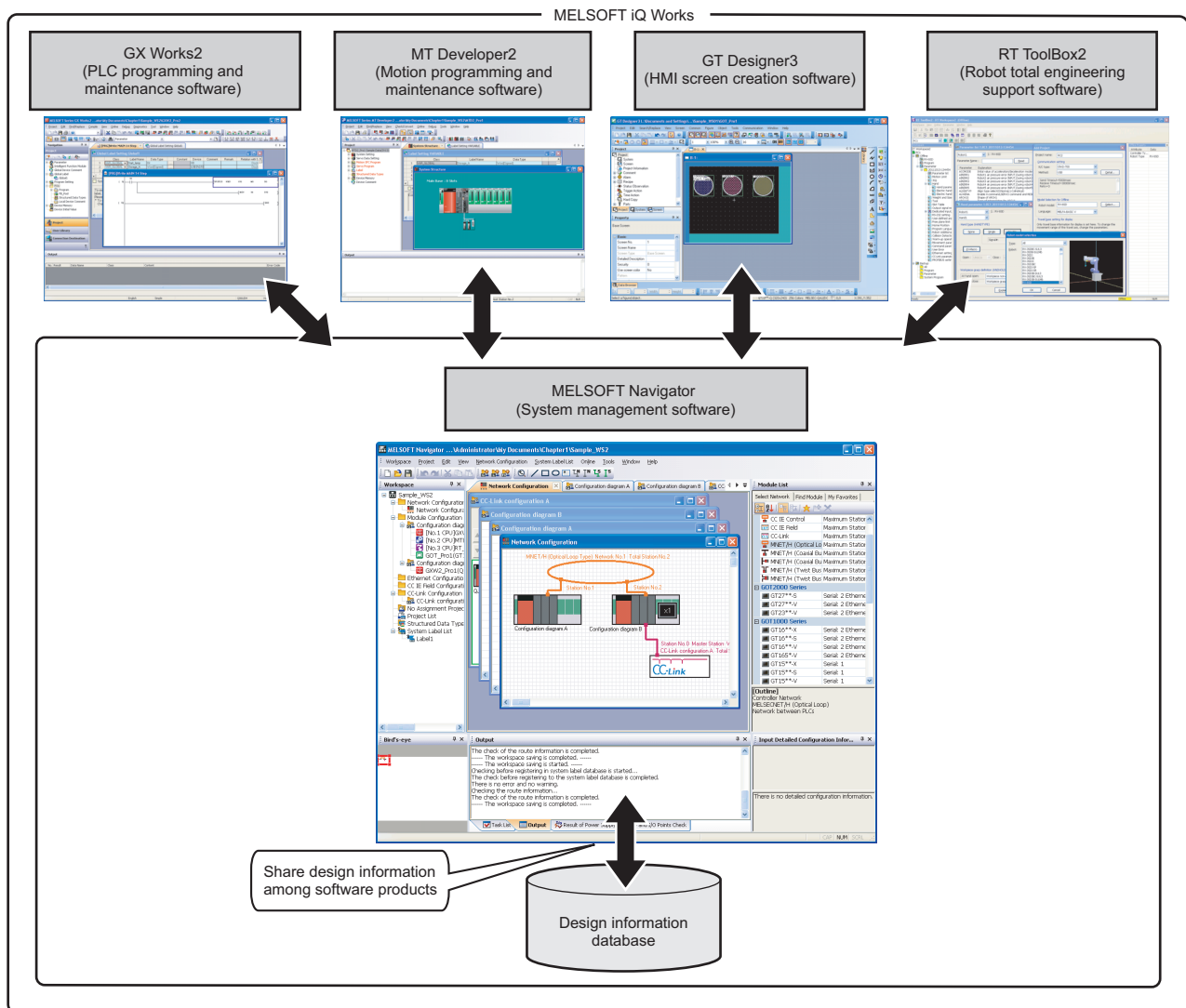

### Point

To start MELSOFT Navigator and engineering software products, select an item registered in the start menu by following the procedures below.

- MELSOFT Navigator : Select [MELSOFT Application] ⇒ [MELSOFT iQ Works] ⇒ [MELSOFT Navigator].
- GX Works2 : Select [MELSOFT Application] ⇒ [GX Works2] ⇒ [GX Works2].
- MT Developer2 : Select [MELSOFT Application] ⇒ [MT Works2] ⇒ [MT Developer2].
- GT Designer3 : Select [MELSOFT Application] ⇒ [GT Works3] ⇒ [GT Designer3].
- RT ToolBox2 : Select [MELSOFT Application] ⇒ [RT ToolBox2] ⇒ [RT ToolBox2].

# 1.2 Features

This section explains the features of MELSOFT iQ Works.

## Project management using graphical system configuration diagrams

Projects are managed by using graphically displayed diagrams of the actual hardware equipment configuration of the whole system, linking each equipment and the project.

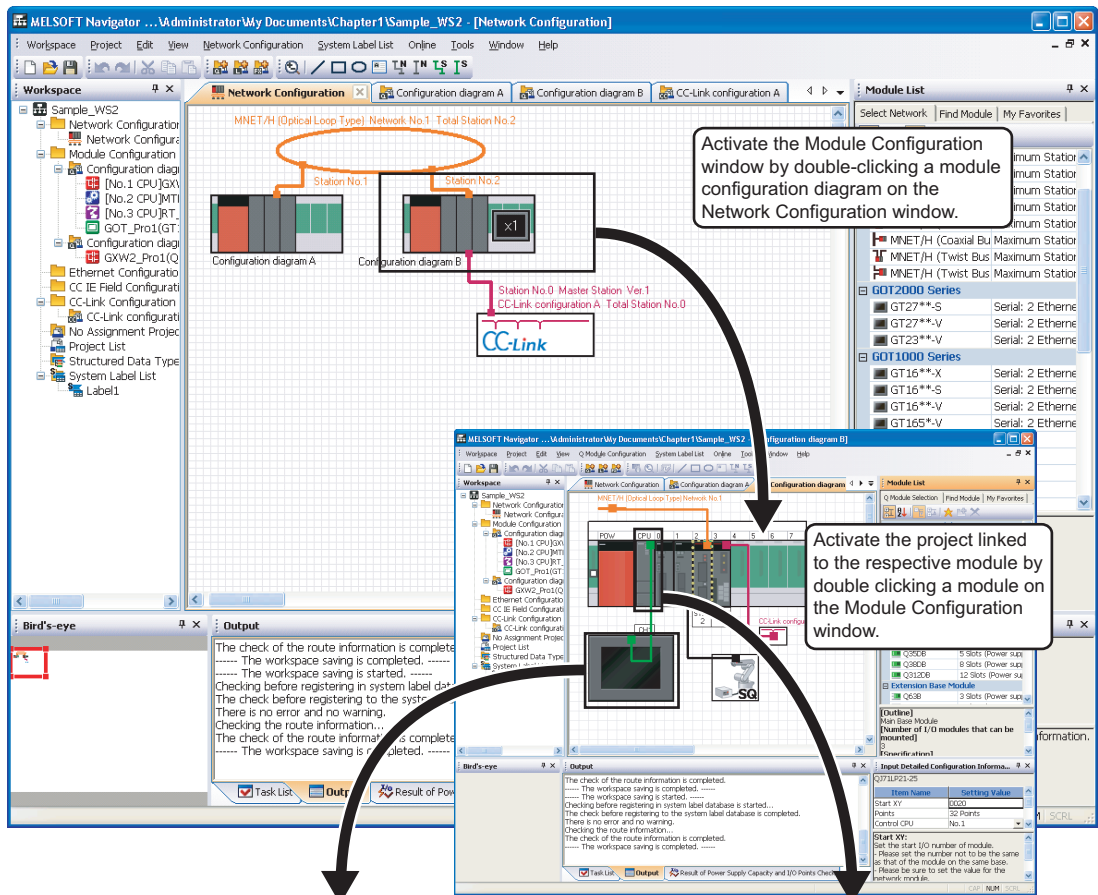

1 OVERVIEW

2 SCREEN CONFIGURATION

3 OPERATING PROCEDURE OF MELSOFT NAVIGATOR

4 USING SYSTEM LABELS

5 CREATING SYSTEM BACKUP DATA

6 USING PROGRAM JUMP FUNCTION

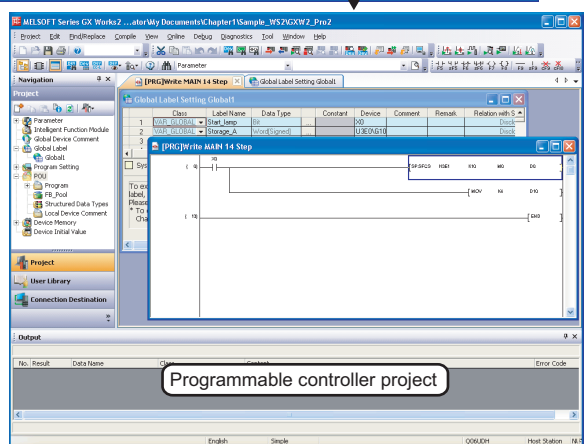
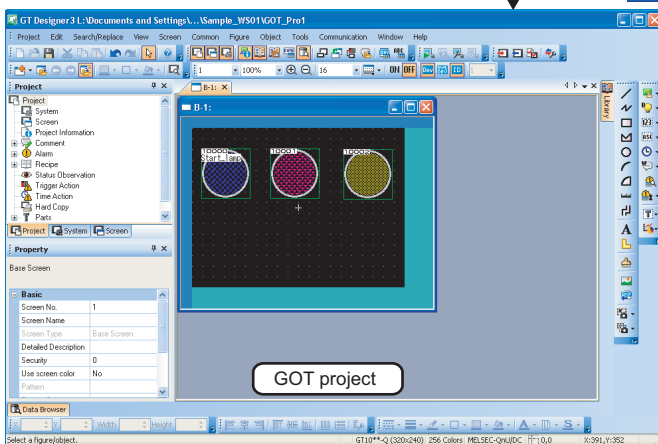

## ■ Improved project management efficiency

### ● Multiple project management using a workspace

Multiple project data (programmable controller projects, motion controller projects, GOT projects, and robot controller projects) can be managed totally using a workspace.

Created date and modified date of each project can be confirmed with the project list.

The screenshot shows the MELSOFT Navigator workspace. The main window displays a configuration diagram of a PLC rack with modules like CPU, I/O, and power supply. Below it, a 'Bird's-eye' view shows a log of workspace operations. To the right, a 'Module List' shows various PLC modules. Four arrows point from the workspace to four smaller screenshots below, each representing a different project type: Programmable controller project, Motion controller project, GOT project, and Robot controller project.

**Programmable controller project**

**Motion controller project**

**GOT project**

**Robot controller project**

## Simplified parameter settings

Parameters, such as I/O assignment and network parameters, which require consistencies can be set without opening related projects of each engineering software (GX Works2, MT Developer2, and GT Designer3).

Parameters set to the project on CPU No. 1 can be utilized for the project on CPU No. 2 when configuring multiple CPU system.

For the parameter setting function, refer to the following chapter.

### Chapter 3

< I/O assignment/Network parameter >

Parameters are set by reflecting them to the project.

Item Name	Setting Value
Start XY	0020
Points	32 Points
Control CPU	No.1
Network Type	MNET/H Mode (Normal Station)
Group No.	0
Station No.	2

**Start XY:**  
 Set the start I/O number of module.  
 - Please set the number not to be the same as that of the module on the same base.  
 - Please be sure to set the value for the network module.  
 - Please set with hexadecimal number and set the last 1 digit to 0, (Setting Range: 0000 to 0FF0)

< Multiple CPU parameter >

QCPU (CPU No. 1)

Motion controller (CPU No. 2)

Multiple CPU parameter of CPU No. 1

Utilize

Multiple CPU parameter of CPU No. 2 and other CPUs

1	OVERVIEW
2	SCREEN CONFIGURATION
3	OPERATING PROCEDURE OF MELSOFT NAVIGATOR
4	USING SYSTEM LABELS
5	CREATING SYSTEM BACKUP DATA
6	USING PROGRAM JUMP FUNCTION

## ■ Improved programming efficiency using system labels

System labels are labels that can be used in any project within the workspace (within the equipment configured in the network configuration diagram or module configuration diagram). Programming (drawing) efficiency is improved by opening devices of programmable controller projects and motion controller projects as system labels, and sharing them with multiple projects. As the device assignment settings are changed in batch, device assignment changes are not necessary on other projects or graphics.

For using system labels, refer to the following chapter.

➔ Chapter 4

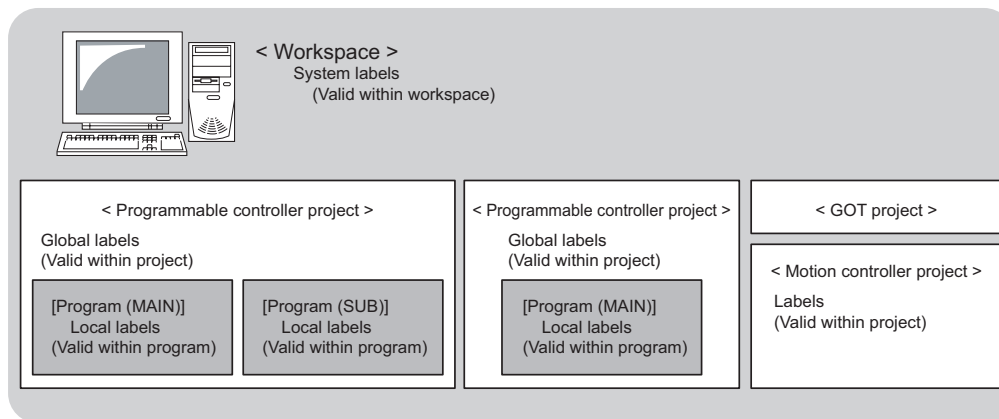

To use system labels in iQ Platform supporting engineering environment MELSOFT iQ Works, utilize system labels registered in MELSOFT Navigator from projects (Top-down design method), or register global labels defined in projects as system labels (Bottom-up design method).

● Top-down design method

Design system labels for accessing GOT or communicating between equipment after designing network configuration in the upstream design.

In top-down design method, register system labels using MELSOFT Navigator, import them to global labels of controller projects, and assign devices.

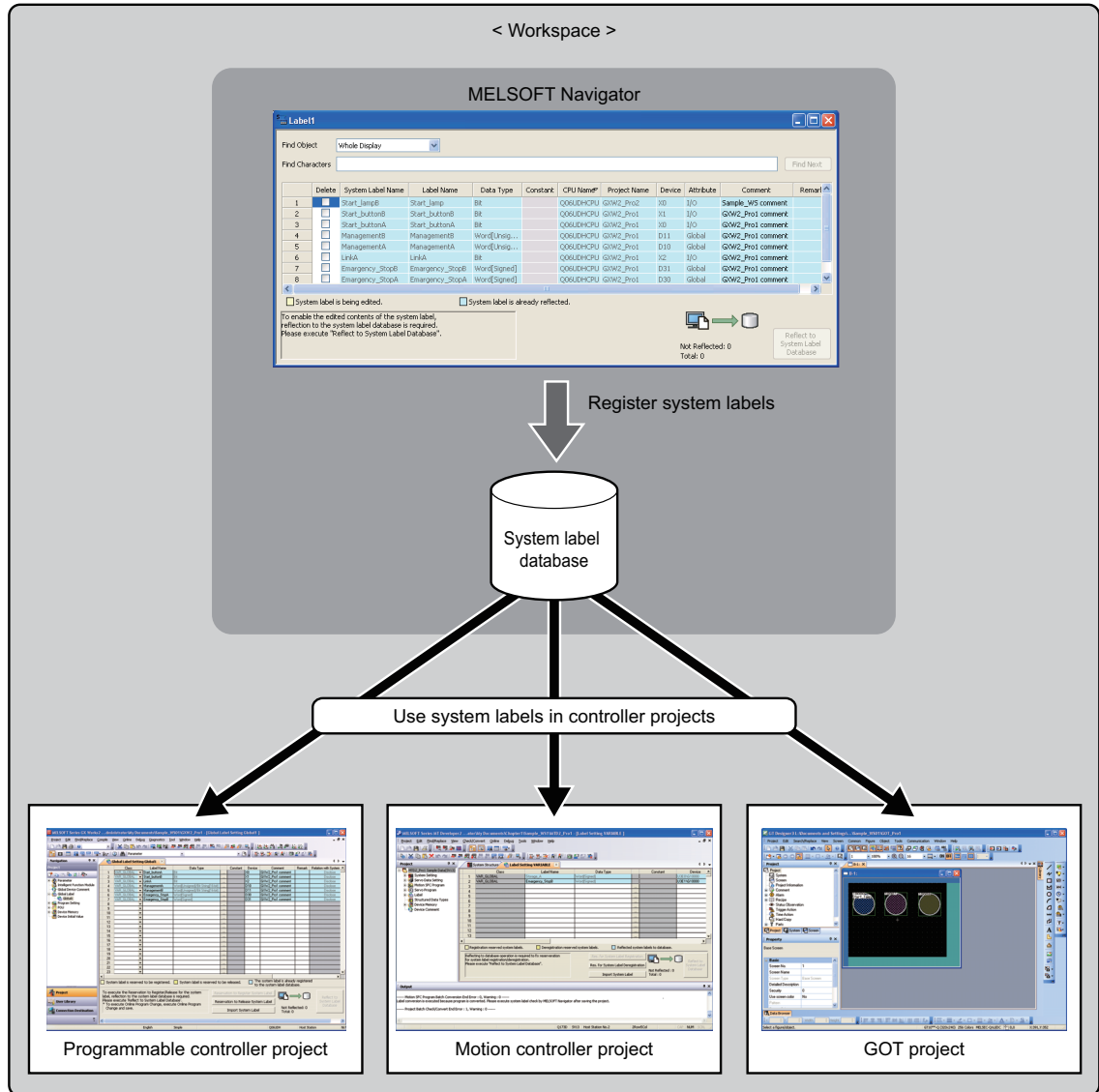

1	OVERVIEW
2	SCREEN CONFIGURATION
3	OPERATING PROCEDURE OF MELSOFT NAVIGATOR
4	USING SYSTEM LABELS
5	CREATING SYSTEM BACKUP DATA
6	USING PROGRAM JUMP FUNCTION

● Bottom-up design method

Design system labels for accessing GOT by using global labels which are registered in controller projects as system labels, for a such case when configuring system by utilizing existing projects.

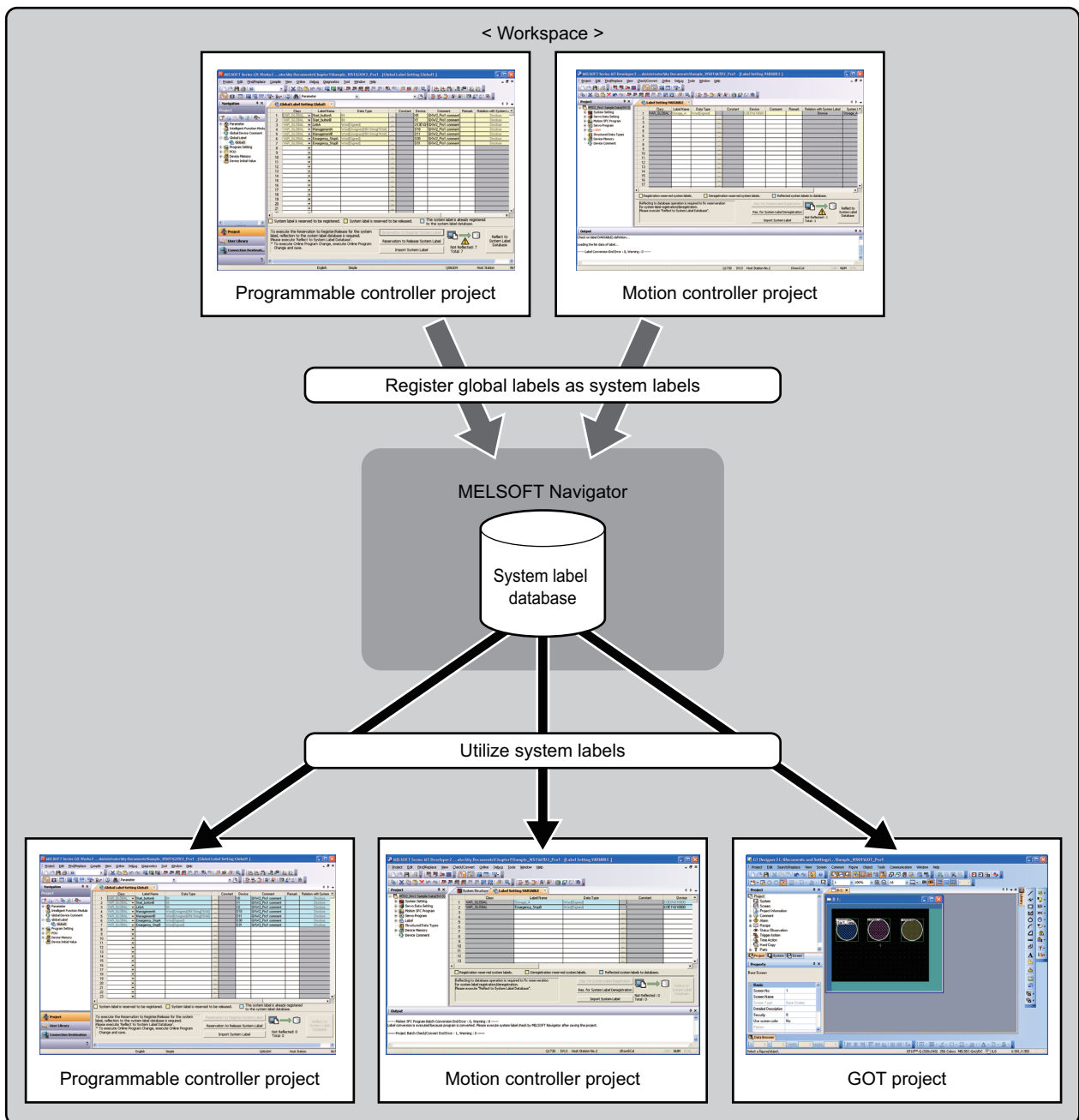



■ Simplified data backup operation

All controller projects in the workspace can be read and saved in batch without activating respective engineering software (GX Works2, MT Developer2, and GT Designer3). For the batch read function, refer to the following chapter.

☞ Chapter 5

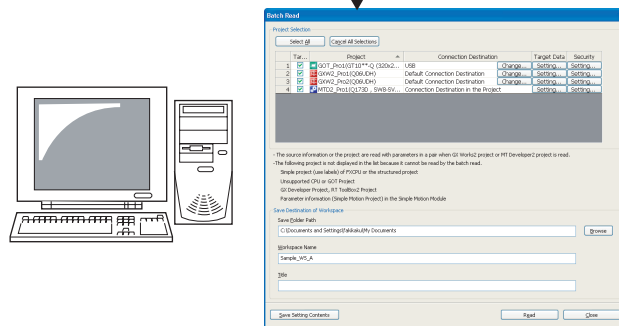
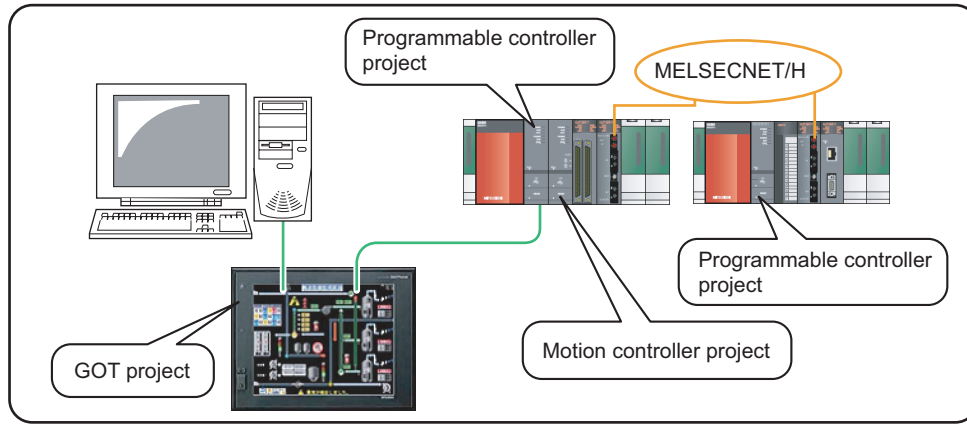

Create backup data in batch

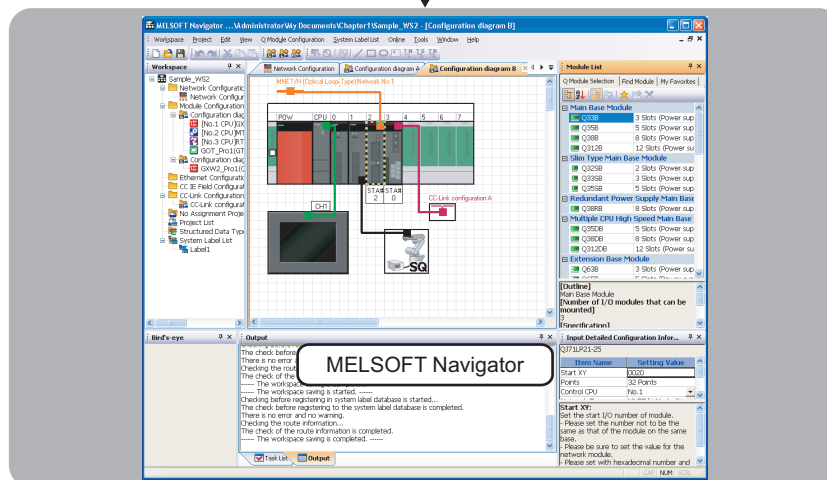

MELSOFT Navigator

1	OVERVIEW
2	SCREEN CONFIGURATION
3	OPERATING PROCEDURE OF MELSOFT NAVIGATOR
4	USING SYSTEM LABELS
5	CREATING SYSTEM BACKUP DATA
6	USING PROGRAM JUMP FUNCTION

■ Improved programming efficiency by linking with motion controller programs

A motion controller program, which corresponds to the motion dedicated programmable controller instruction selected in the sequence program, can be activated by a simple mouse operation. This function significantly improves programming efficiency.

For the program jump function, refer to the following chapter.

👉 Chapter 6

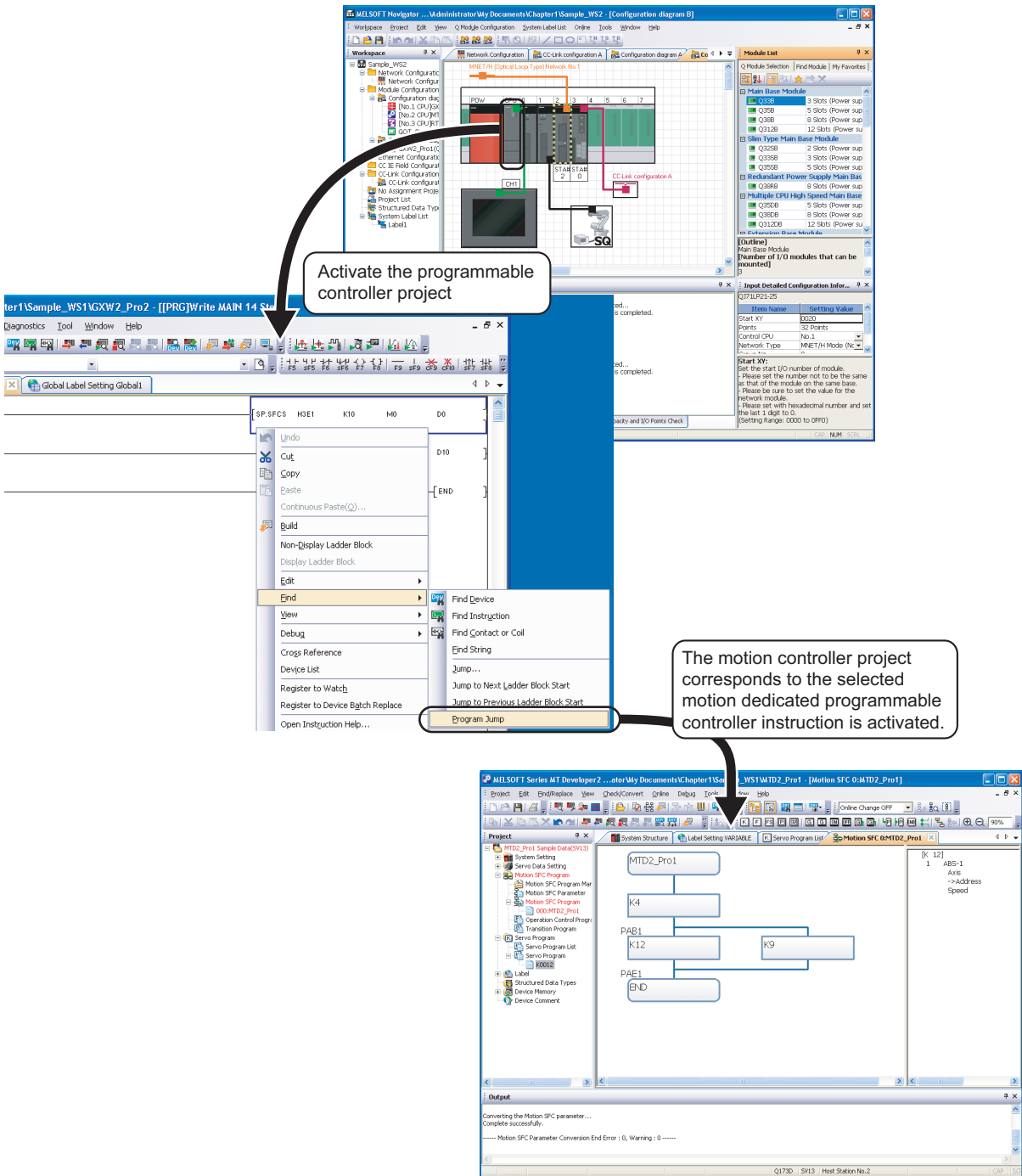



# 2 SCREEN CONFIGURATION

This chapter explains the screen configuration of MELSOFT Navigator.

2.1 Screen Configuration ..... 2-2

1	OVERVIEW
2	SCREEN CONFIGURATION
3	OPERATING PROCEDURE OF MELSOFT NAVIGATOR
4	USING SYSTEM LABELS
5	CREATING SYSTEM BACKUP DATA
6	USING PROGRAM JUMP FUNCTION

## 2.1 Screen Configuration

The following explains the screen configuration.

### Screen display

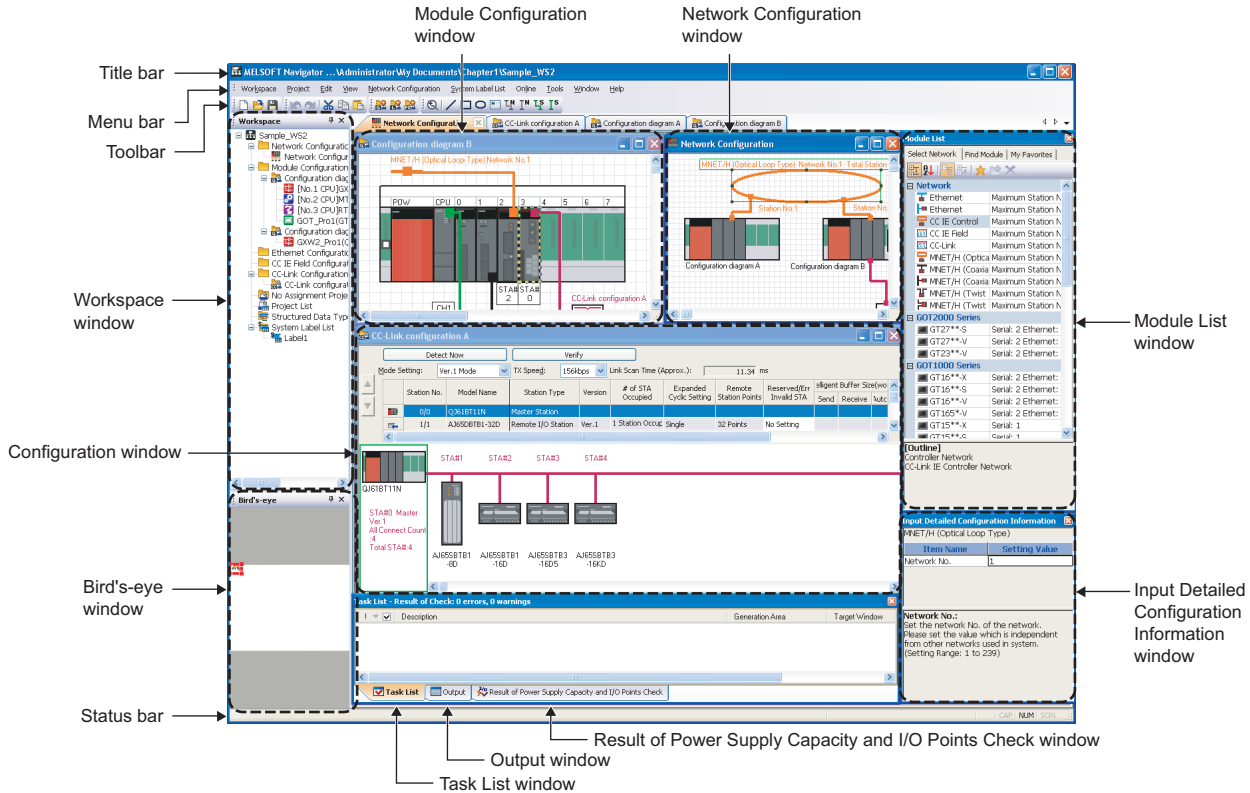

### Display contents

Name	Description
Title bar	Displays a title of product name, workspace path, and active window.
Menu bar	Displays items of the basic menu.
Toolbar	Displays tool buttons for functions executed frequently.
Workspace window	Displays objects managed in a workspace in tree format.
Bird's-eye window	Displays a bird's-eye view of the Network Configuration window.
Module Configuration window	Set details of graphical Q series/L series/FX series module configurations which are allocated in the network configuration diagram.
Network Configuration window	Set graphical network configuration.
Configuration window	Set configurations and display them graphically.
Module List window	Displays modules used in Q series/L series/FX series in list form.
Input Detailed Configuration Information window	Set I/O assignment and network parameters required in MELSOFT Navigator.
Output window	Displays messages and log outputs being processed in the parameter reflection process in list form.
Task List window	Displays a result of system configuration check, power supply capacity and I/O points check or system label consistency check in list form.
Result of Power Supply Capacity and I/O Points Check window	Displays a result of power supply capacity and I/O points check.
Status bar	Displays information about the selected project.



Help information of MELSOFT iQ Works can be displayed by pressing the **F1** key.

<b>1</b>	OVERVIEW
<b>2</b>	SCREEN CONFIGURATION
<b>3</b>	OPERATING PROCEDURE OF MELSOFT NAVIGATOR
<b>4</b>	USING SYSTEM LABELS
<b>5</b>	CREATING SYSTEM BACKUP DATA
<b>6</b>	USING PROGRAM JUMP FUNCTION





# 3 OPERATING PROCEDURE OF MELSOFT NAVIGATOR

This chapter explains the methods for creating workspaces and system configurations using MELSOFT Navigator.

3.1	Procedure of MELSOFT Navigator from Start to End . . . . .	3-2
3.2	Starting MELSOFT Navigator . . . . .	3-3
3.3	Creating Workspaces . . . . .	3-4
3.4	Creating System Configuration Diagram . . . . .	3-8
3.5	Creating Projects . . . . .	3-30
3.6	Setting Parameters . . . . .	3-38
3.7	Checking System Configuration . . . . .	3-47
3.8	Editing Projects . . . . .	3-49
3.9	Reading/Writing/Verifying Controller Data . . . . .	3-53
3.10	Saving Workspaces . . . . .	3-56
3.11	Printing Workspaces . . . . .	3-58
3.12	Closing Workspaces . . . . .	3-59
3.13	Exiting MELSOFT Navigator . . . . .	3-60

1	OVERVIEW
2	SCREEN CONFIGURATION
3	OPERATING PROCEDURE OF MELSOFT NAVIGATOR
4	USING SYSTEM LABELS
5	CREATING SYSTEM BACKUP DATA
6	USING PROGRAM JUMP FUNCTION

## 3.1 Procedure of MELSOFT Navigator from Start to End

This section explains the procedure of MELSOFT Navigator from start to end.

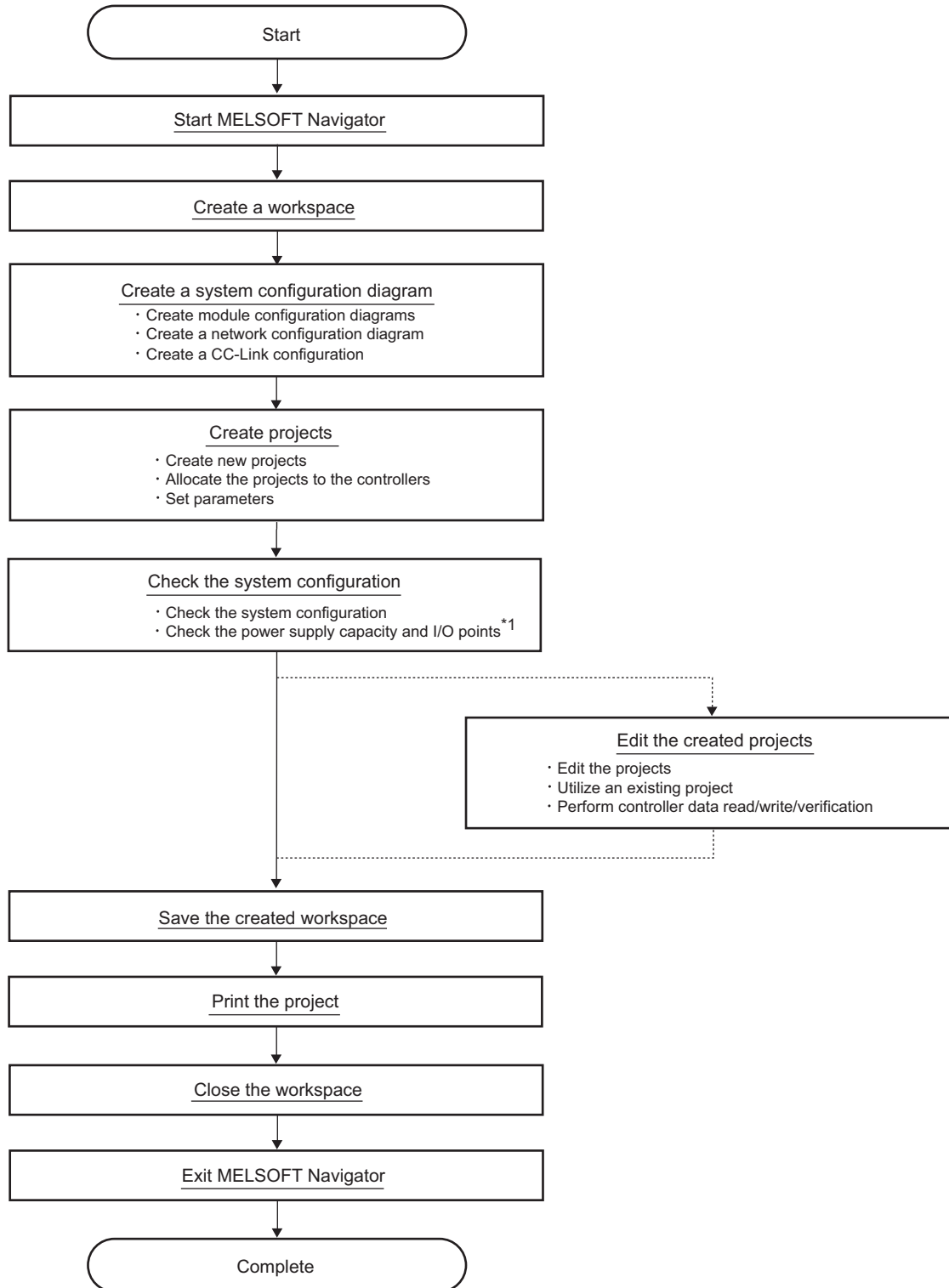

\*1 : Not supported by FXCPU.

### Point

Do not change the storage location and names of folders/files of a created workspace/project using the application such as Windows® Explorer.



## 3.2 Starting MELSOFT Navigator

This section explains a method for starting MELSOFT Navigator.

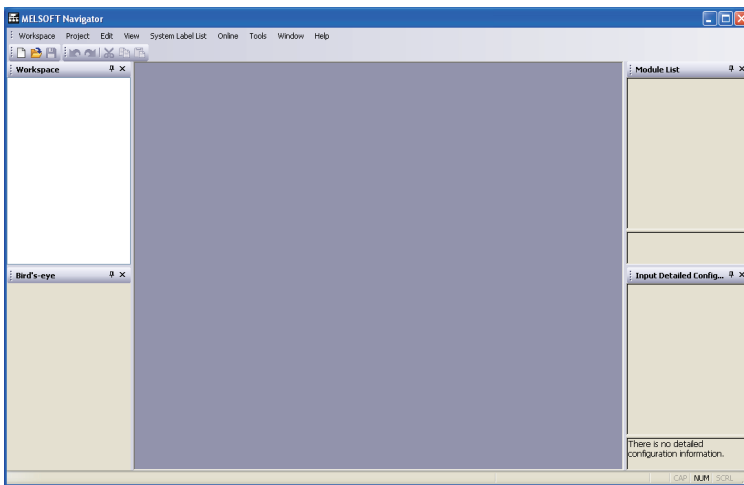
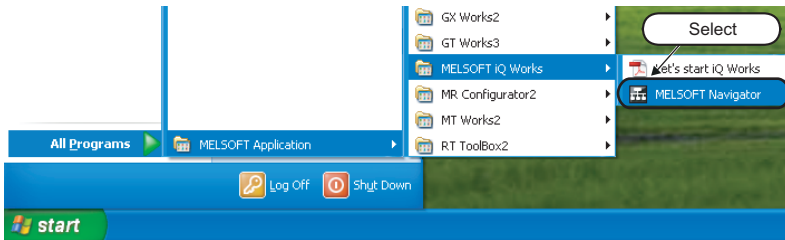

1. Start MELSOFT Navigator from Windows [Start] menu.

2. MELSOFT Navigator is activated.

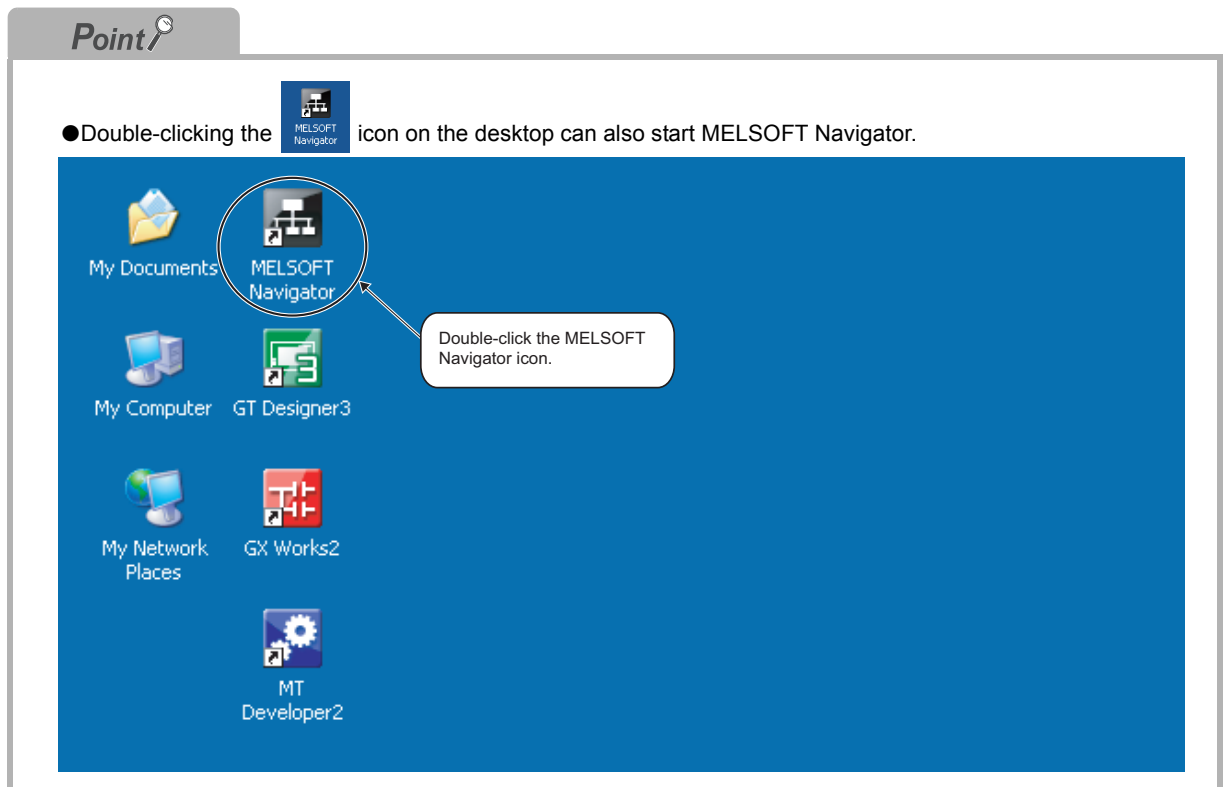

● Double-clicking the  icon on the desktop can also start MELSOFT Navigator.

Double-click the MELSOFT Navigator icon.

## 3.3 Creating Workspaces

This section explains a method for creating a new workspace.

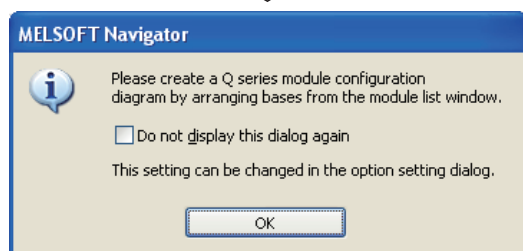
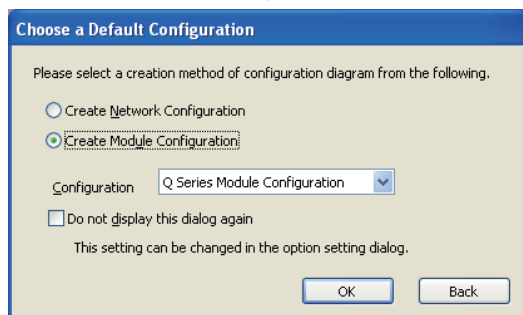
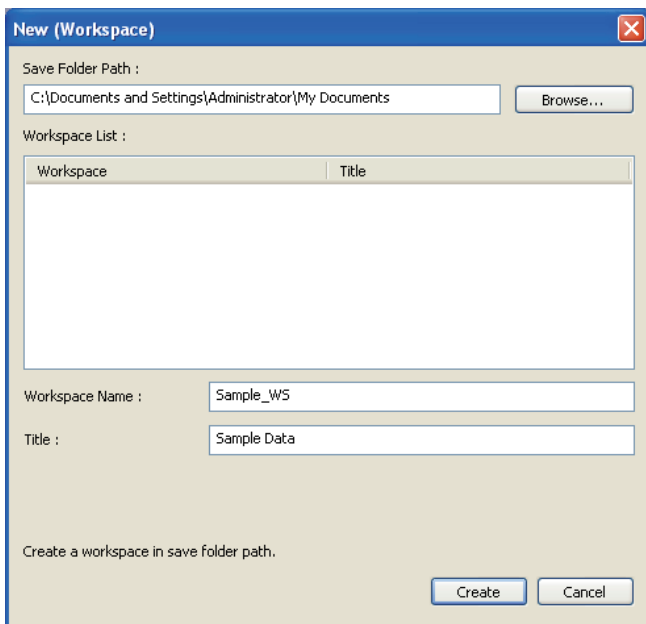
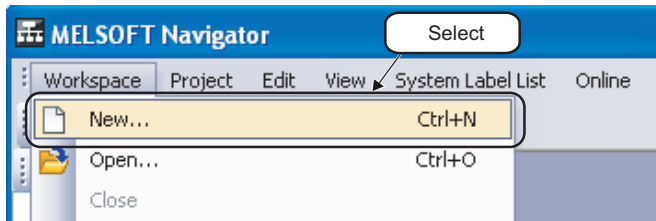

(To the next page)

1. Select [Workspace] ⇒ [New] (  ) in the menu bar to display the "New (Workspace)" dialog box.

2. Set "Save Folder Path", "Workspace Name", and "Title" for the new workspace.

After setting the items, click the  button.

#### Setting example

- Save Folder Path : C:\Documents and Settings\  
Administrator\  
My Documents
- Workspace Name: Sample\_WS
- Title (option) : Sample Data

3. The "Choose a Default Configuration" dialog box is displayed.

Select "Create Module Configuration" and click the  button.

#### Setting example

- Configuration : Q Series  
Module Configuration

4. The message shown on the left is displayed.

Read the message and click the  button.

(From the previous page)

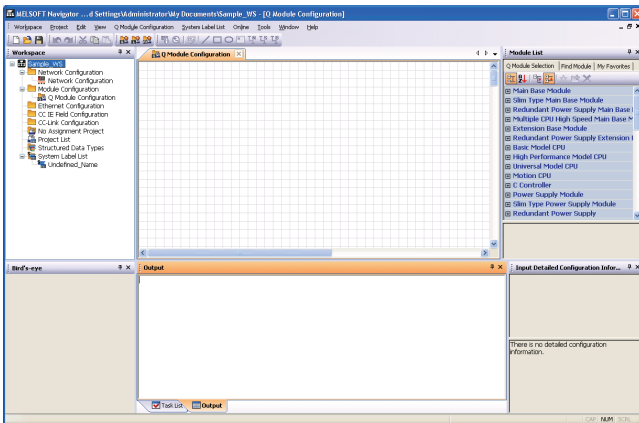



5. The new workspace is created.

### Point

#### ● Opening existing workspaces

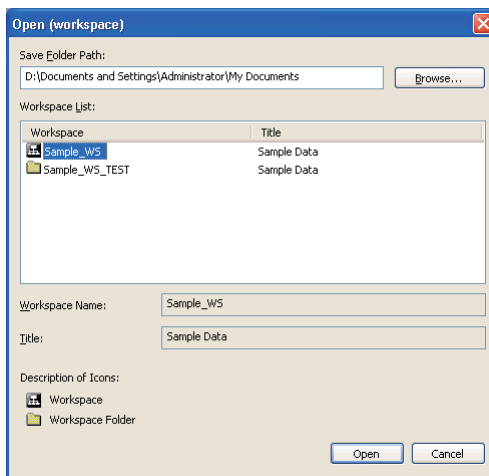
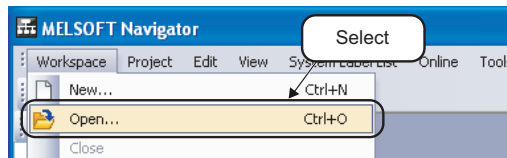
Open an existing workspace by following the procedure below.



1. Select [Workspace] ⇒ [Open] (  ) in the menu bar to display the "Open (Workspace)" dialog box.

2. Select "Save Folder Path" and "Workspace" for the workspace to be opened.

The workspace folder copied by the application such as Windows® Explorer can be selected.

After selecting the items, click the  button to open the workspace.

#### Setting example

- Save Folder Path : C:\Documents and Settings\  
Administrator\  
My Documents
- Workspace Name: Sample\_WS

1 OVERVIEW

2 SCREEN CONFIGURATION

3 OPERATING PROCEDURE OF MELSOFT NAVIGATOR

4 USING SYSTEM LABELS

5 CREATING SYSTEM BACKUP DATA

6 USING PROGRAM JUMP FUNCTION

### Point

#### ● Creating workspaces for motion system using templates

Workspaces for motion system can be created from templates consist of a combination of programmable controller CPU and motion controller, which are used for multiple CPU system configuration.

The following shows the procedure to create a workspace for motion system using a template.

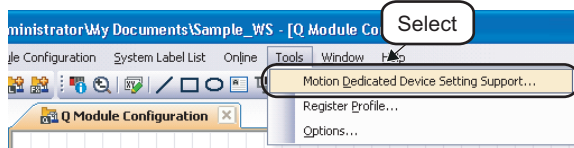

1. Select [Tools] ⇒ [Motion Dedicated Device Setting Support] in the menu bar to display the "Select Motion System Template" dialog box.

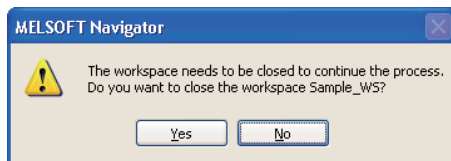

2. The message shown on the left is displayed.

Read the message and click the  button to display the "Select Motion System Template" dialog box.

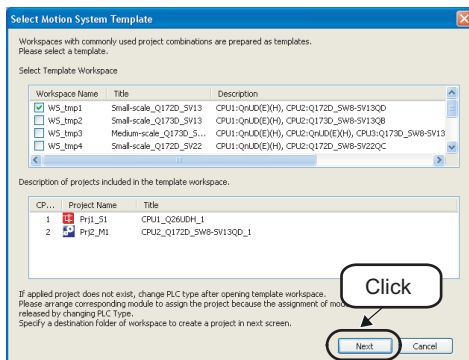

3. Select a workspace name in "Select Template Workspace", and click the  button.

The "Motion Dedicated Device Setting Support" dialog box is displayed.

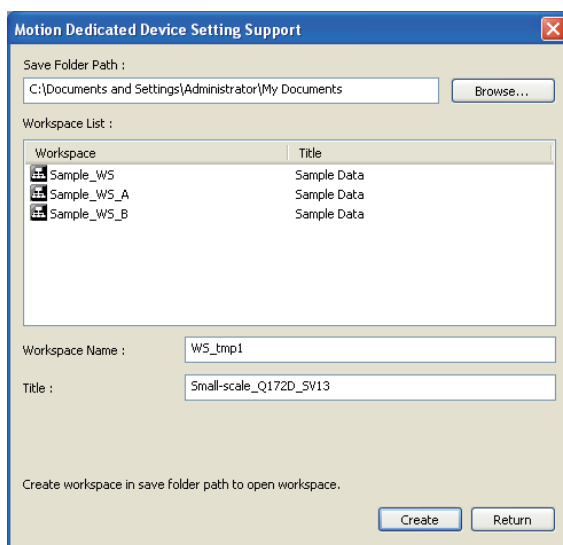

4. Set "Save folder path" and "Workspace name" for the template workspace.

After setting the items, click the  button.

#### Setting example

- Save Folder Path : C:\Documents and Settings\  
Administrator\  
My Documents
- Workspace Name: WS\_tmp1

(To the next page)

Point

(From the previous page)

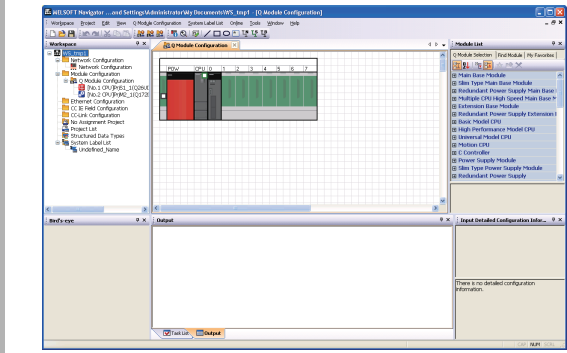

5. The workspace for motion system is displayed.

1 OVERVIEW

2 SCREEN CONFIGURATION

3 OPERATING PROCEDURE OF MELSOFT NAVIGATOR

4 USING SYSTEM LABELS

5 CREATING SYSTEM BACKUP DATA

6 USING PROGRAM JUMP FUNCTION

### 3.4 Creating System Configuration Diagram

This section explains a method for creating a system configuration diagram. Created module configuration diagrams are reflected to the network configuration diagram.

#### 3.4.1 System configuration to be created

Create the following system configuration diagram.

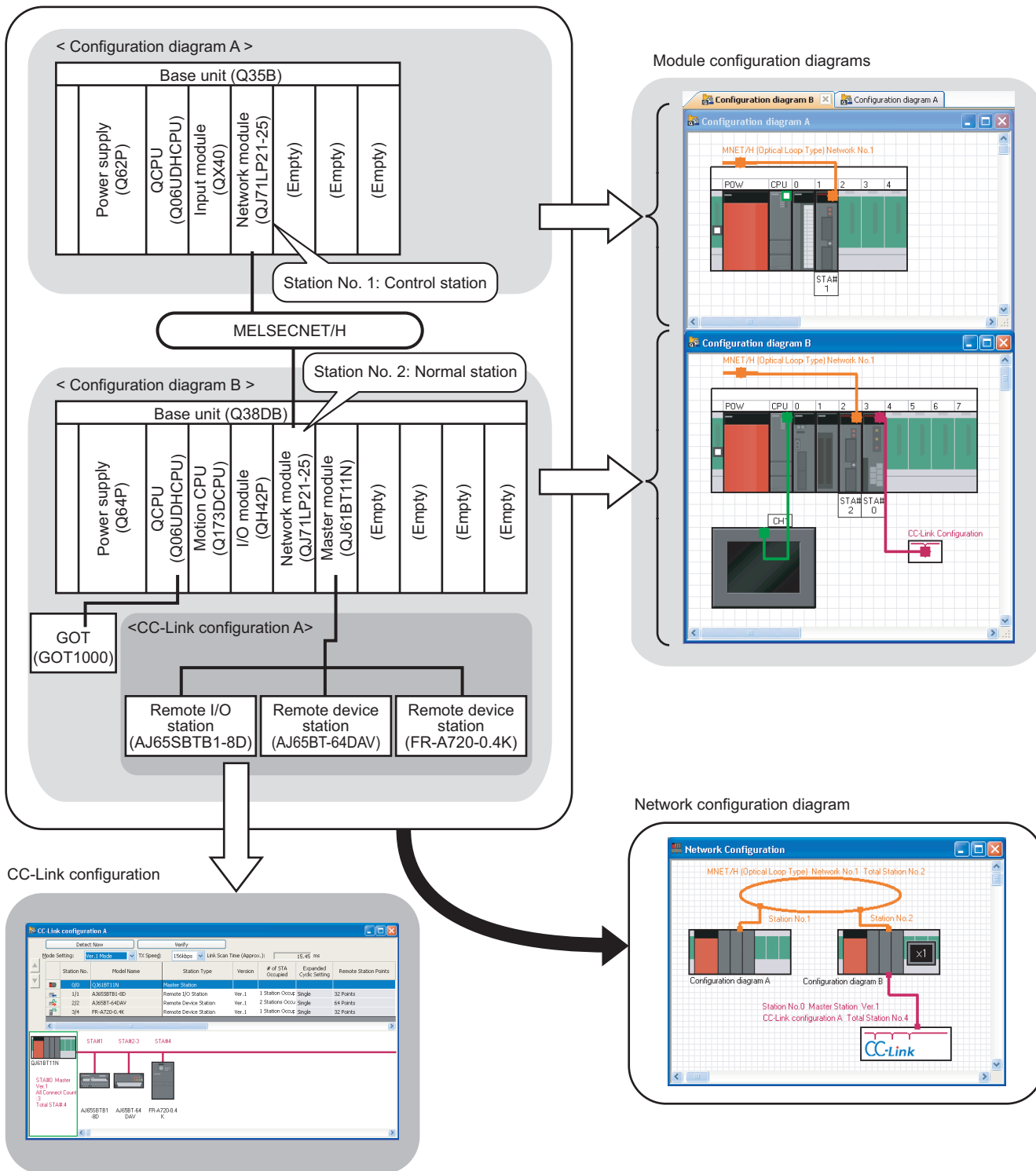

CC-Link configuration

Network configuration diagram

## 3.4.2 Creating module configuration diagrams

Create Data module configuration diagrams by placing modules on the Module Configuration window.

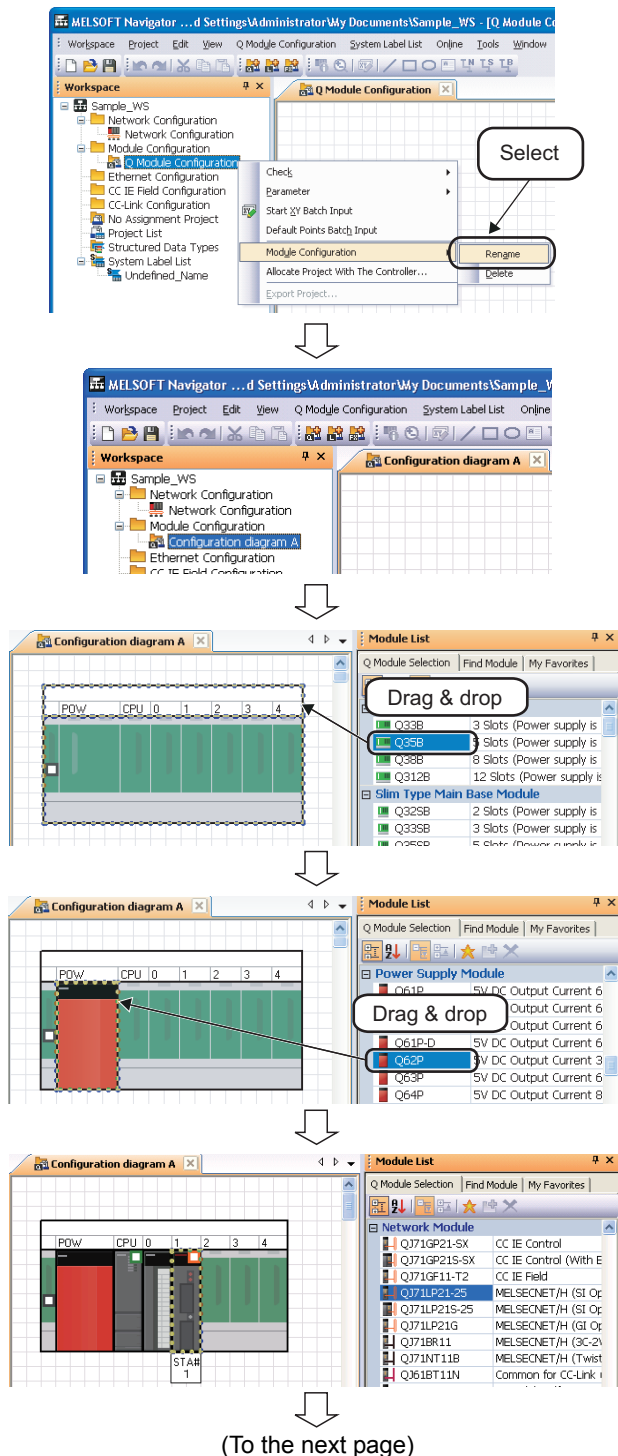

1. Right-click "Q Module Configuration" on the Workspace window, and select [Module Configuration] ⇒ [Rename] in the shortcut menu.
2. Enter "Configuration diagram A" to change the module configuration diagram name.
3. Select the base unit ( Q35B ) from the Module List window, and drag and drop it onto the Module Configuration window.
4. Select the power supply module ( Q62P ) from the Module List window, and drag and drop it onto the base unit.
5. Select modules from the Module List window, and drag and drop them onto the base unit following the same procedure in the step 4, and complete the creation of "Configuration diagram A".

1 OVERVIEW

2 SCREEN CONFIGURATION

3 OPERATING PROCEDURE OF MELSOFT NAVIGATOR

4 USING SYSTEM LABELS

5 CREATING SYSTEM BACKUP DATA

6 USING PROGRAM JUMP FUNCTION

(From the previous page)

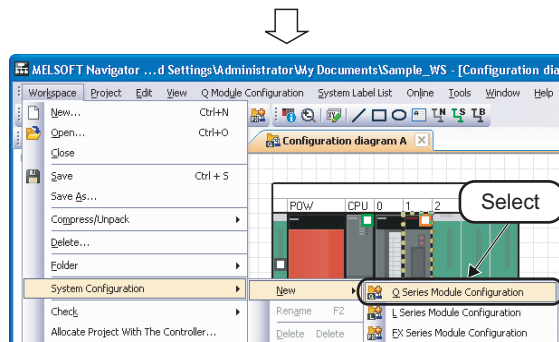

6. Select [Workspace] ⇒ [System Configuration] ⇒ [New] ⇒ [Q Series Module Configuration], and create a new module configuration diagram.

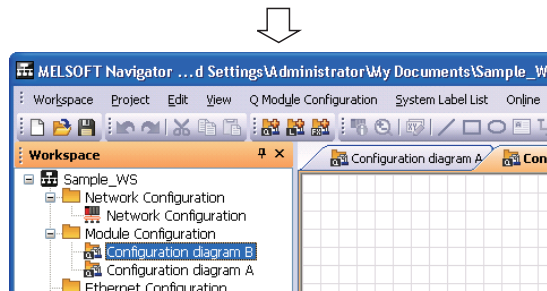

7. Change the module configuration name to "Configuration diagram B" following the same procedure in the step 1 and step 2.

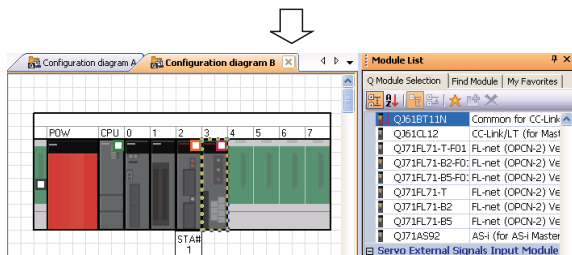

8. Select modules from the Module List window, and drag and drop them onto the base unit following the same procedure in the step 3 and step 4.

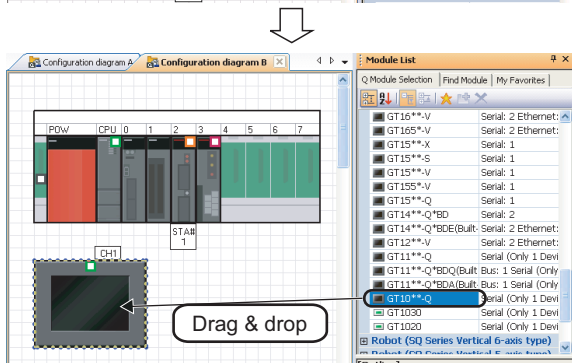

9. Select the GOT unit (  GT10\*\*-Q ) from the Module List window, and drag and drop it onto the Module Configuration window.

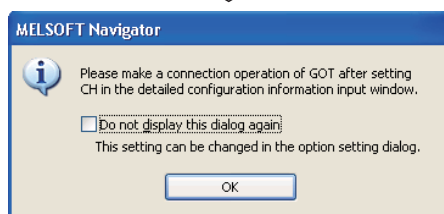

10. The message shown on the left is displayed.

Read the message and click the  button.

(To the next page)



(From the previous page)

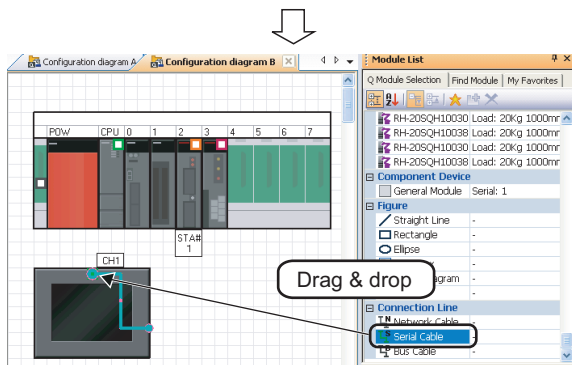

11. Select Serial Cable (  Serial Cable ) from the Module List window, and drag and drop it onto the connection port of the GOT unit.

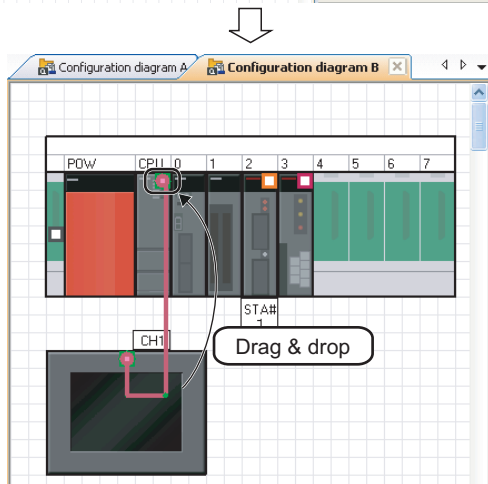

12. Drag and drop the edge of connection line to the connection port of the connection target CPU module.

The GOT unit is connected to the CPU module.

1 OVERVIEW

2 SCREEN CONFIGURATION

3 OPERATING PROCEDURE OF MELSOFT NAVIGATOR

4 USING SYSTEM LABELS

5 CREATING SYSTEM BACKUP DATA

6 USING PROGRAM JUMP FUNCTION

**Point**

● **Mounting modules**

- When a module is dragged onto the base unit, the mountable area of the base unit is displayed in light green as shown below.

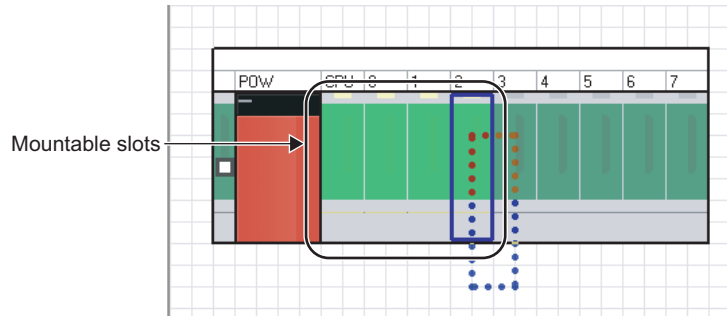

- If a module is not mounted properly, the whole module is displayed in pink as shown below.

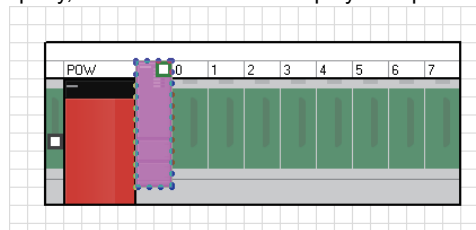

● **Connection lines**

When a connection line is dragged and dropped onto the Module Configuration window, the connectable ports of each controller are displayed as shown below.

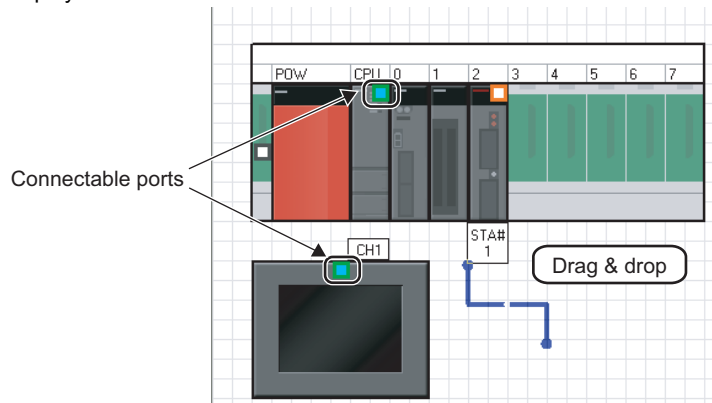

● **Connection points of GOT unit**

By setting parameters on the Input Detailed Configuration Information window, I/F type and number of connectable points of GOT unit can be changed.

Item Name	Setting Value
Personal Computer Conn	USB
Personal Computer Conn	No Setting
IP Address	192.168.3.18
CH1 I/F	Standard I/F (RS232C)
CH1 Driver	A/QnA/L/Q CPU, L371C
CH1 Station No.	
CH1 Network Type	
CH1 Port No.	
CH2 I/F	Standard I/F (Ethernet)
CH2 Driver	Standard I/F (RS232C)
CH2 Station No.	Standard I/F (RS422/485)
CH2 Network Type	Standard I/F (Ethernet)
CH2 Port No.	Extend I/F-1 (1st stage)
CH3 I/F	Extend I/F-1 (3rd stage)
CH3 Station No.	Extend I/F-2 (1st stage)
CH3 Network Type	Extend I/F-2 (2nd stage)
CH3 Port No.	Extend I/F-2 (3rd stage)
CH4 I/F	Set with GT Designer3
CH4 Station No.	No Setting
CH4 Network Type	
CH4 Port No.	

■ Creating module configuration diagrams for L series

For L series, create module configuration diagrams refer to this section. Basically, L series module configurations can be created in a similar way to Q series. For operations that differ from Q series, refer to the Point in this section.

- System configuration to be created  
Create the following system configuration.

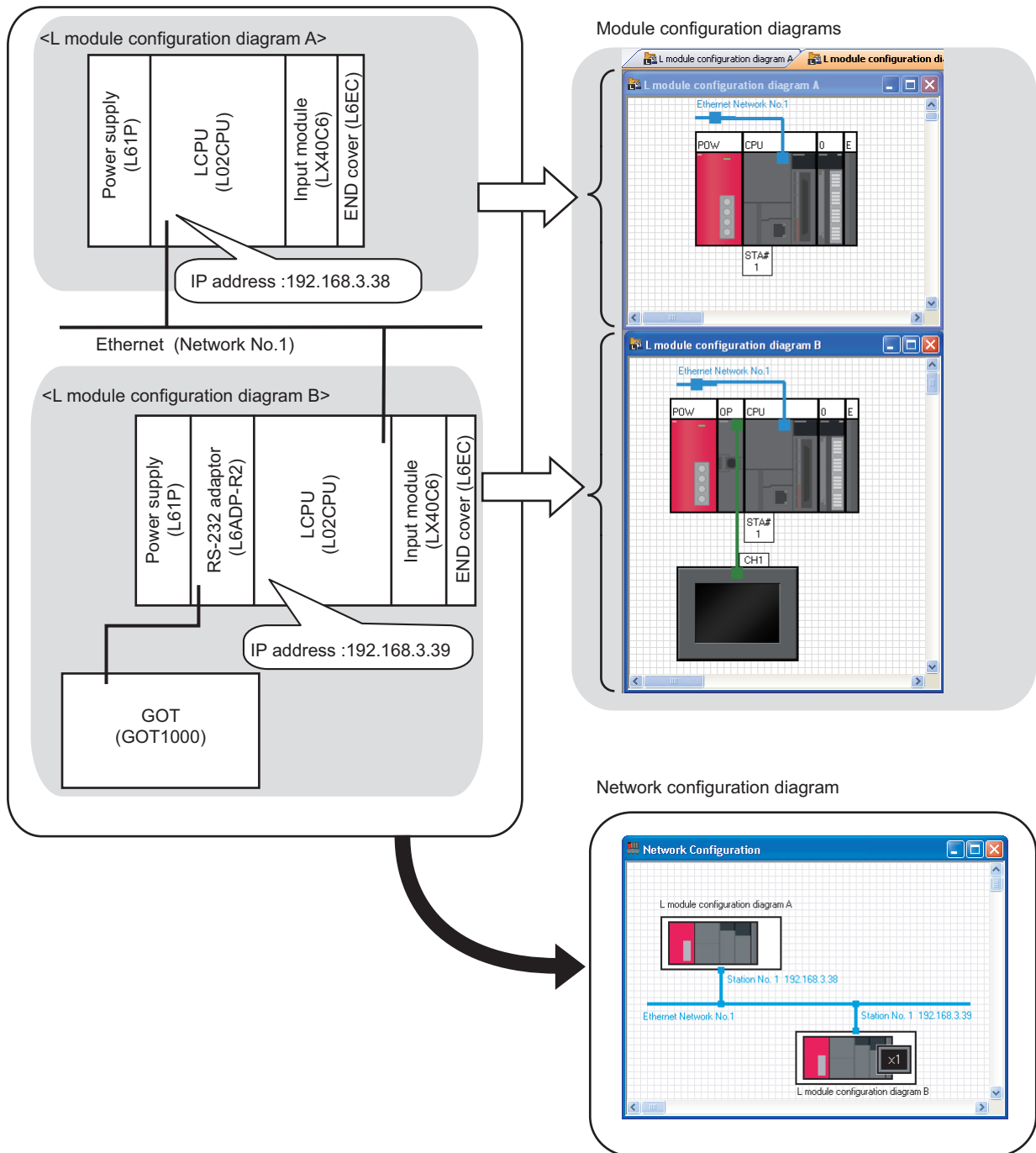

1	OVERVIEW
2	SCREEN CONFIGURATION
3	OPERATING PROCEDURE OF MELSOFT NAVIGATOR
4	USING SYSTEM LABELS
5	CREATING SYSTEM BACKUP DATA
6	USING PROGRAM JUMP FUNCTION

### ● Creating module configuration diagrams

Create module configuration diagrams by placing modules on the Module Configuration window.

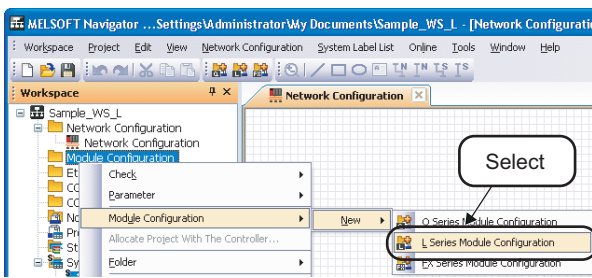

1. Right-click "Module Configuration" on the Workspace window, and select [Module Configuration] ⇒ [New] ⇒ [L Series Module Configuration] in the shortcut menu.

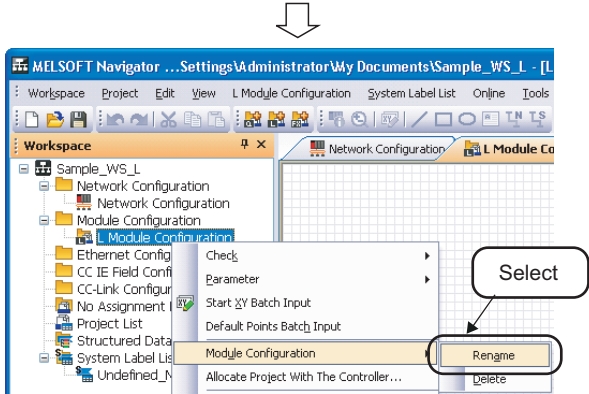

2. Right-click "L Module Configuration" on the Workspace window, and select [Module Configuration] ⇒ [Rename] in the shortcut menu.

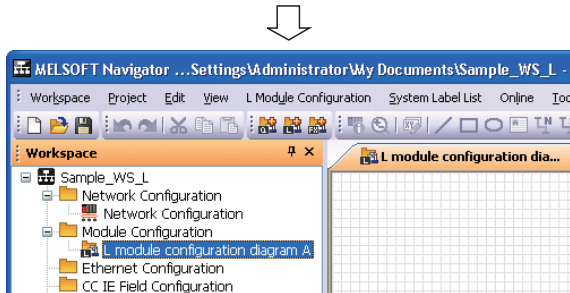

3. Enter "L module configuration diagram A" to change the module configuration diagram name.

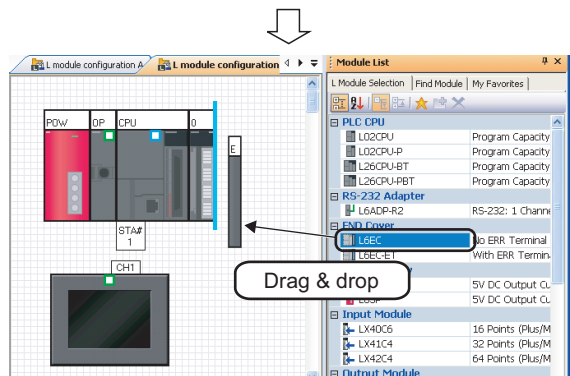

4. Select modules from the Module List window, and drag and drop them onto the Module Configuration window following the same procedure in the step 4 through step11 in section 3.4.2.

**Point**

● **Creating L series module configurations**

When creating workspaces, select "L Series Module Configuration" in the "Choose a Default Configuration" dialog box.

For creating workspaces, refer to the following section.

☞ 3.3 Creating Workspaces

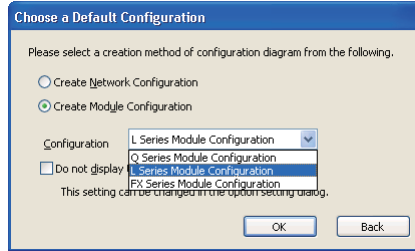

● **Mounting modules**

When a module is dragged onto the Module Configuration window, the mountable areas are displayed in light blue as shown below.

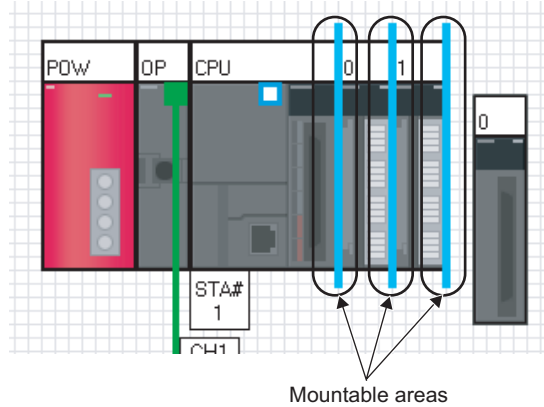

● **Deleting modules**

When a module is deleted from the Module Configuration window, the modules next to the deleted module are connected automatically as shown below.

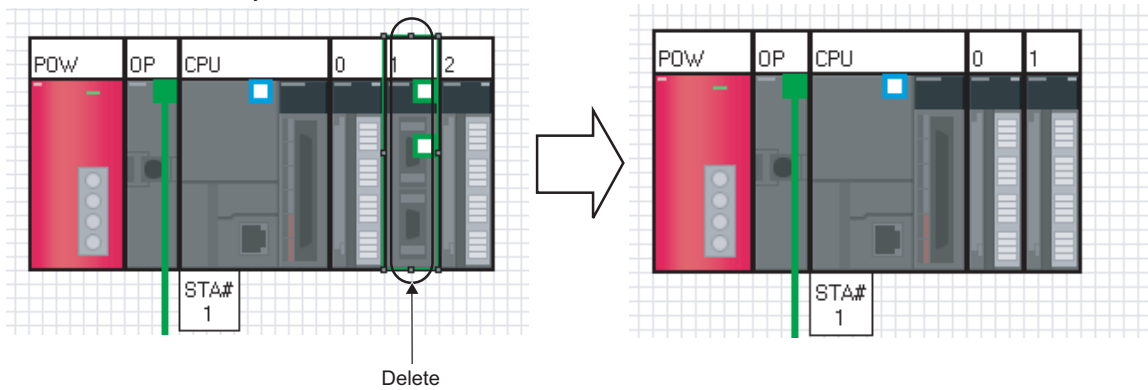

1	OVERVIEW
2	SCREEN CONFIGURATION
3	OPERATING PROCEDURE OF NELSOF NAVIGATOR
4	USING SYSTEM LABELS
5	CREATING SYSTEM BACKUP DATA
6	USING PROGRAM JUMP FUNCTION

### Point

#### ● Mounting display module

Display module can be mounted on L series CPU modules.  
Mount display module by following procedure below.

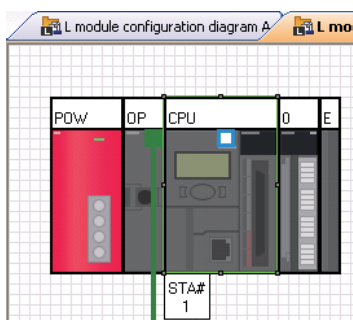
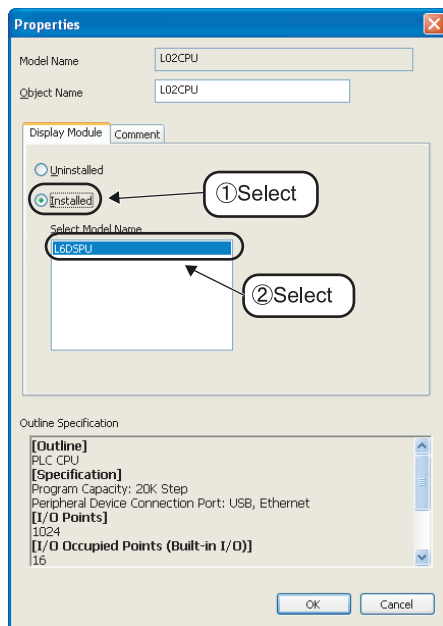
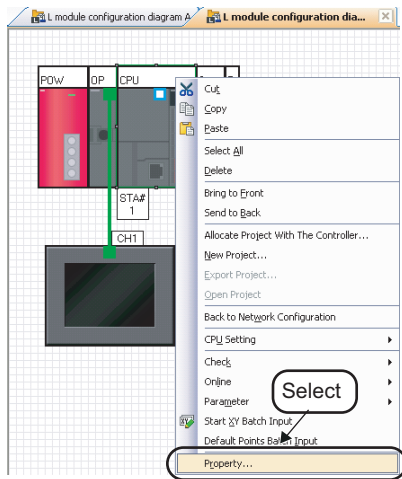

1. Right click the controller on the Module Configuration window, and select [Property] in the shortcut menu.

2. The "Properties" dialog box is displayed.

Select "Installed" in the Display Module tab and select the model name to be mounted from "Select Model Name"

#### Setting example

- Select Model Name :L6DSPU

3. Click the  button.

Display module is mounted on the controller.

■ Creating module configuration diagrams for FX series

For FX series, create module configuration diagrams refer to this section.

Basically, FX series module configurations can be created in a similar way to Q series.

For operations that differ from Q series, and for main units, special blocks, and special adapters that can be used in FX series, refer to the Point in this section.

● System configuration to be created

Create the following system configuration.

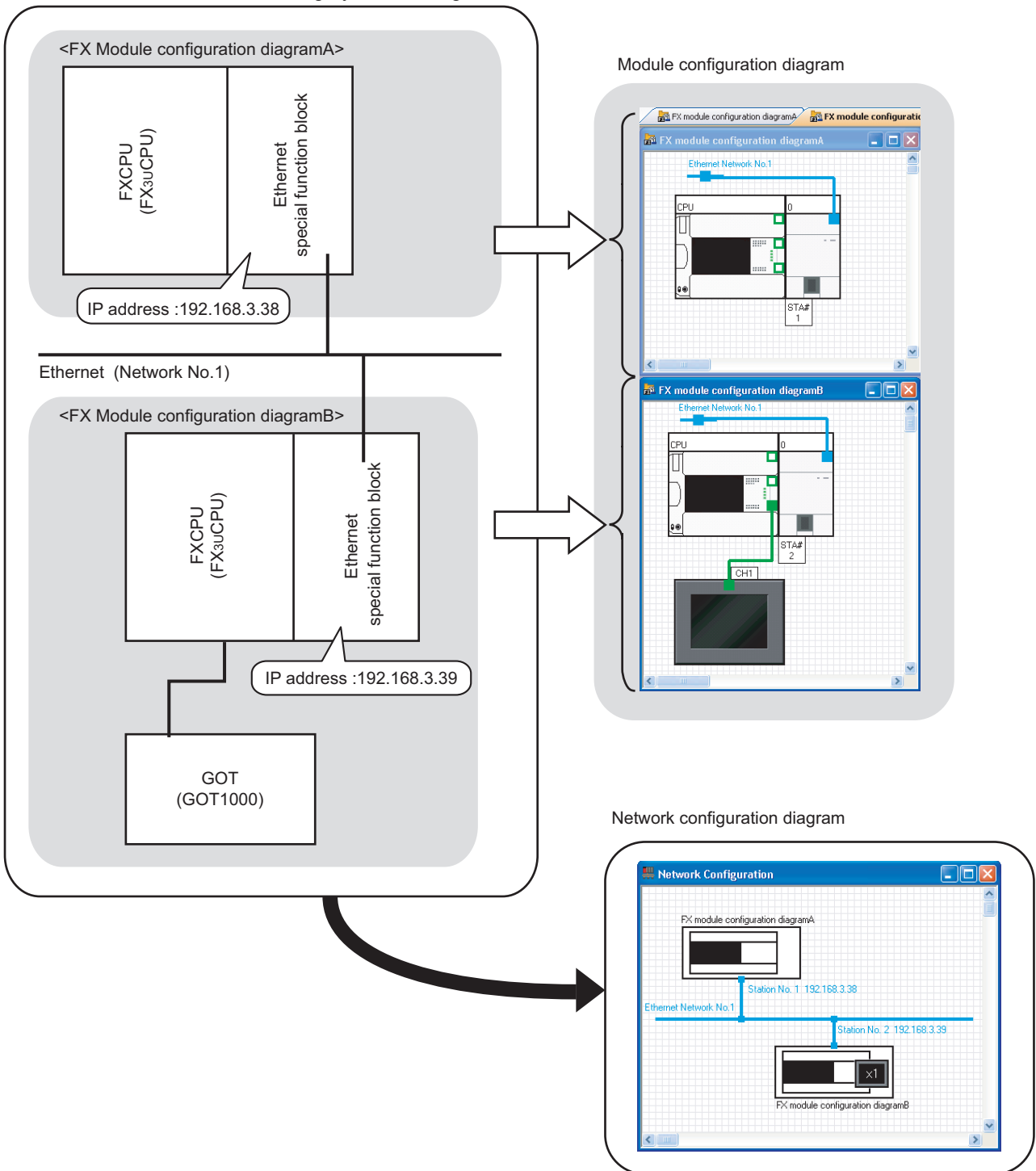

1	OVERVIEW
2	SCREEN CONFIGURATION
3	OPERATING PROCEDURE OF MELSOFT NAVIGATOR
4	USING SYSTEM LABELS
5	CREATING SYSTEM BACKUP DATA
6	USING PROGRAM JUMP FUNCTION

### ● Creating module configuration diagrams

Create module configuration diagrams by placing modules on the Module Configuration window.

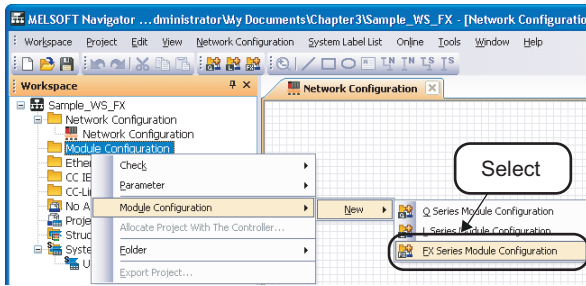

1. Right-click "Module Configuration" on the Workspace window, and select [Module Configuration] ⇒ [New] ⇒ [FX Series Module Configuration] in the shortcut menu.

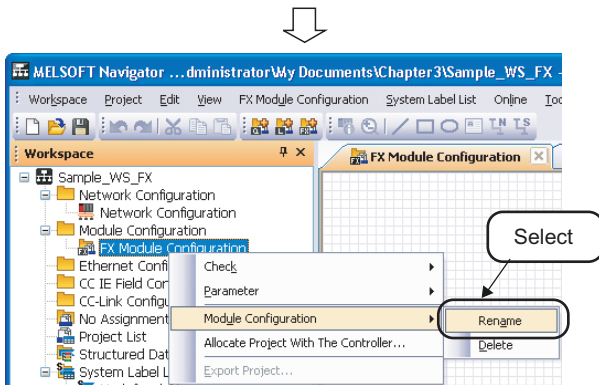

2. Right-click "FX Module Configuration" on the Workspace window, and select [Module Configuration] ⇒ [Rename] in the shortcut menu.

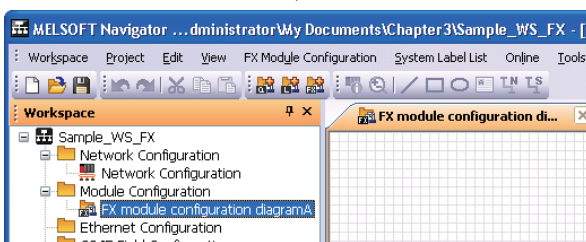

3. Enter "FX module configuration diagramA" to change the module configuration diagram name.

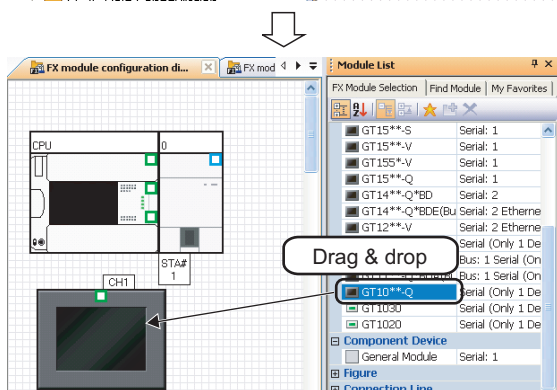

4. Select modules from the Module List window, and drag and drop them onto the Module Configuration window following the same procedure in the step 4 through step11 in section 3.4.2.



### Point

#### ● Creating FX series module configurations

When creating workspaces, select "FX Series Module Configuration" in the "Choose a Default Configuration" dialog box.

For creating workspaces, refer to the following section.

☞ 3.3 Creating Workspaces

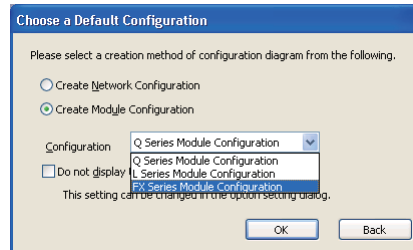

#### ● Mounting modules

When a module is dragged onto the Module Configuration window, the mountable areas are displayed in light blue as shown below.

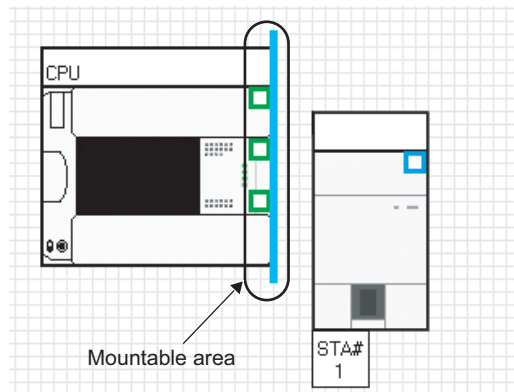

#### ● Supported CPU modules of FX series in MELSOFT Navigator

The following CPU modules of FX series are supported in MELSOFT Navigator.

- Main units  
FX3S, FX3G, FX3GC, FX3U, FX3UC
- Special block  
Ethernet special function block (FX-ENET series)
- Special adapter  
Ethernet communication special adapter (FX3U-ENET-ADP)

For FX series, special blocks and special adapters are mounted to a main unit which combines power supply, CPU, and I/O module. However, the following blocks and units can not be mounted: special blocks and special units which do not contain related project or configuration software, and extension blocks which do not support a function to check power supply capacity and I/O points.

#### ● Parameters of special adapters

The parameters of special adapters can be set on the Input Detailed Configuration Information window.

The setting content is reflected to the parameter of a programmable controller project by performing parameter reflection. For details of the parameter settings, refer to the following section.

☞ Section 3.6 Setting Parameters

#### ● Displaying module list window

The model name of special blocks of FX series compatible with MELSOFT Navigator are displayed on the Module List window when the related software are installed.

When using special blocks install the related software<sup>\*1</sup> of each module in advance.

\*1: The related software of FX-ENET series may be downloaded from MITSUBISHI ELECTRIC FA Global Website.

For the method of obtaining the related software, contact the store where you purchased the product.

### 3.4.3 Creating network configuration diagrams

Create a network configuration diagram by placing and connecting the module configuration diagrams on the Network Configuration window.

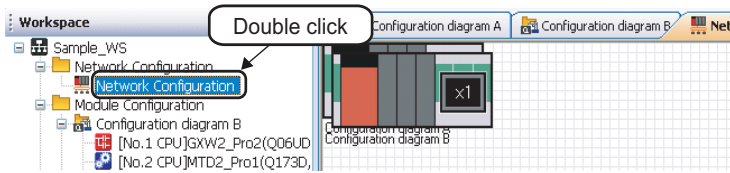

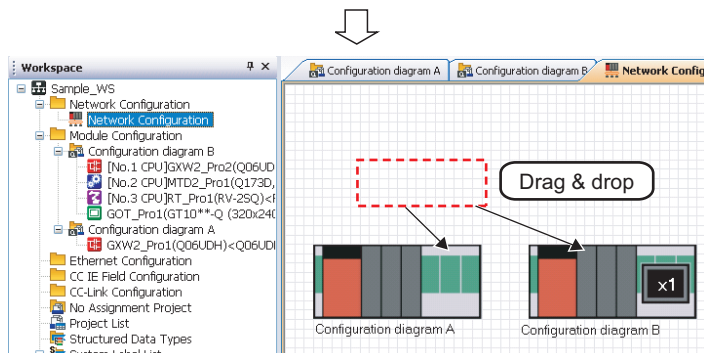

1. Double-click "Network Configuration" on the Workspace window to open the Network Configuration window.

All module configuration diagrams created on the Module Configuration windows are displayed.

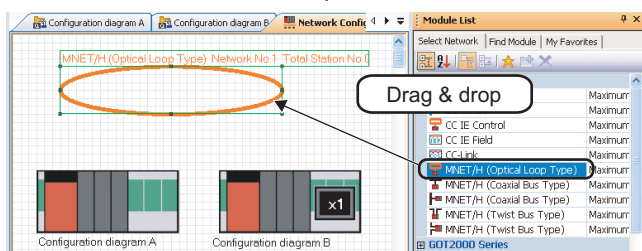

2. Drag and drop the module configuration diagrams to desired positions.



3. Select MNET/H (Optical Loop Type) (  MNET/H (Optical Loop Type) ) from the Module List window, and drag and drop it onto the Network Configuration window.

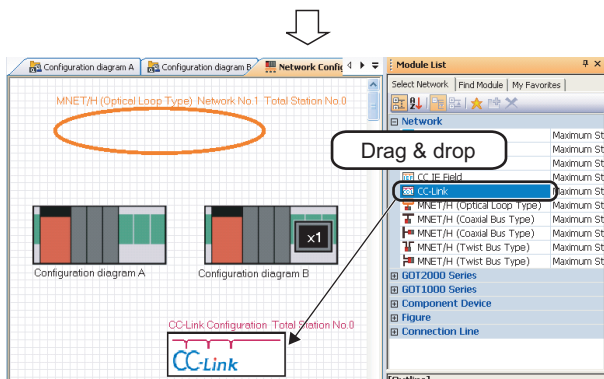



4. Select CC-Link (  CC-Link ) from the Module List window, and drag and drop it onto the Network Configuration window.

CC-Link configuration is added on the Workspace window.

(To the next page)

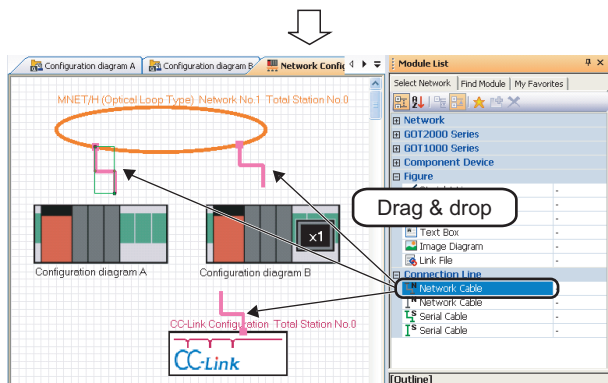
(From the previous page)



5. Select Network Cable (  Network Cable ) from the Module List window, and drag and drop it onto the Network Configuration window.

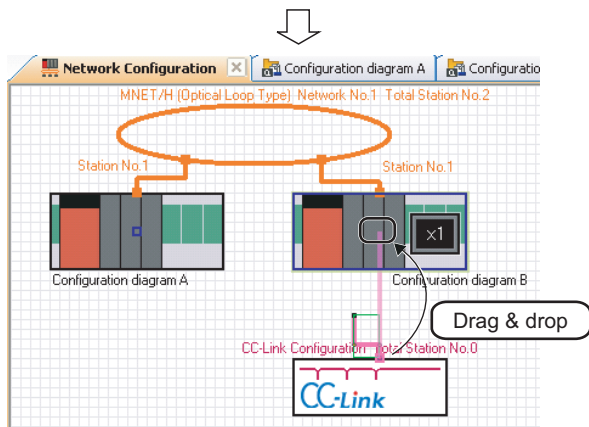

6. Drag and drop the edge of connection line to the connection point of the connection target module configuration diagram.

CC-Link configuration is connected to the module configuration diagram.

**Point**

- Adding Ethernet configuration**  
 When adding Ethernet configuration by dragging and dropping from Module Configuration window onto the Network Configuration window, select an Ethernet configuration from "Component Device"

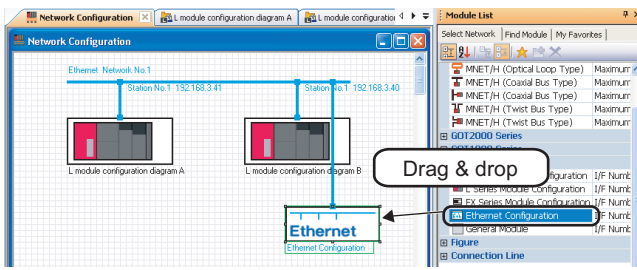

- Network Configuration window**
  - A Module Configuration window opens by double-clicking the module configuration diagram/CC-Link configuration on the Network Configuration window/CC-Link configuration window. For Ethernet/CC IE Field, each configuration window can be opened with the same operation as above.
  - The whole system created on the Network Configuration window can be reviewed on the Bird's-eye window.

1	OVERVIEW
2	SCREEN CONFIGURATION
3	OPERATING PROCEDURE OF NELSOF NAVIGATOR
4	USING SYSTEM LABELS
5	CREATING SYSTEM BACKUP DATA
6	USING PROGRAM JUMP FUNCTION

### 3.4.4 Creating CC-Link configuration diagrams

Create a configuration by placing modules on the CC-Link Configuration window.

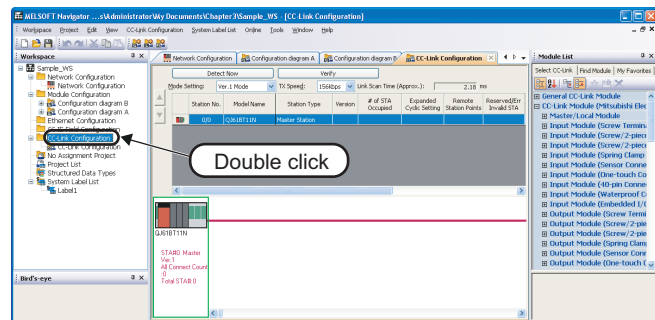

1. Double-click "CC-Link Configuration" on the Workspace window to open the CC-Link Configuration window.

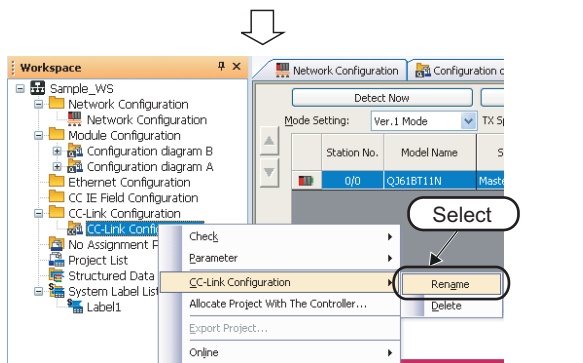

2. Right-click "CC-Link Configuration" on the Workspace window, and select [CC-Link Configuration] ⇒ [Rename] in the shortcut menu.

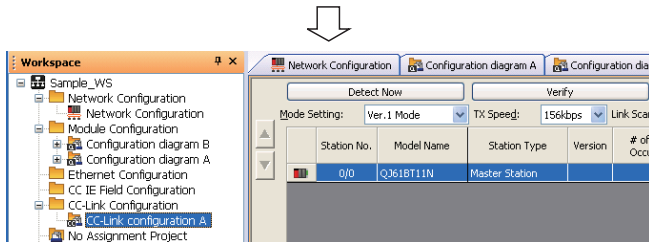

3. Enter "CC-Link configuration A" to change the CC-Link configuration name.

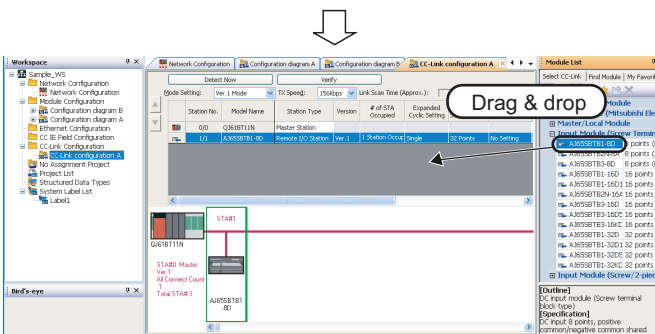

4. Select AJ65SBTB1-8D (AJ65SBTB1-8D) from the Module List window, and drag and drop it onto the CC-Link Configuration window.

CC-Link configuration is added on the Module configuration window.

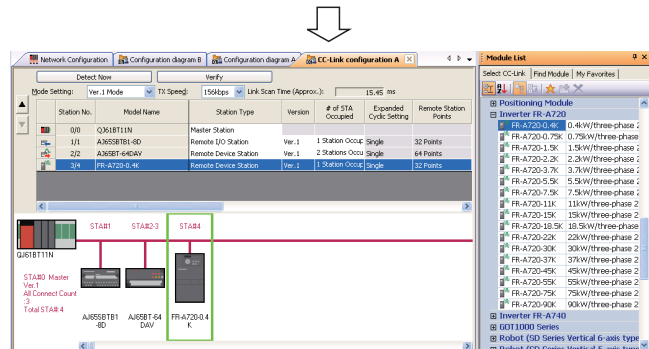

5. Select modules to be connected from the Module List window, and drag and drop them onto the CC-Link Configuration window following the same procedure in the step 4.

### Point

#### ● Module display on configuration window

Check that the network modules on the Module Configuration window are connected to the network. If not, the modules are not displayed on the configuration window.

#### ● Detecting actual system configuration

The actual system configuration can be reflected to the CC-Link Configuration window by performing one of the following operations.

- Click the  button on the CC-Link Configuration window.
- Select [Online] ⇒ [Detect Now].

For the automatic detection of connected devices, refer to the following manual.

 iQ Sensor Solution Reference Manual

#### ● Verifying CC-Link configuration against the actual system configuration

The CC-Link configuration can be verified against the actual system configuration by performing one of the following operations.

- Click the  button on the CC-Link Configuration window.
- Select [Online] ⇒ [Verification of the Configuration with the Connected Module].

For the verification of the configuration with the connected modules, refer to the following manual.

 iQ Sensor Solution Reference Manual

#### ● Deleting CC-Link modules

The following shows a method for deleting CC-Link modules from CC-Link Configuration window.

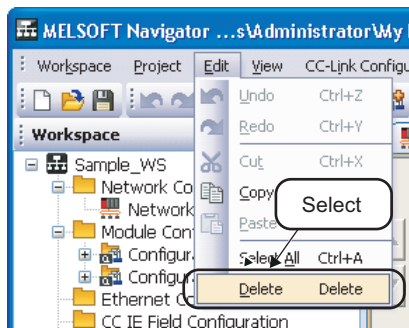
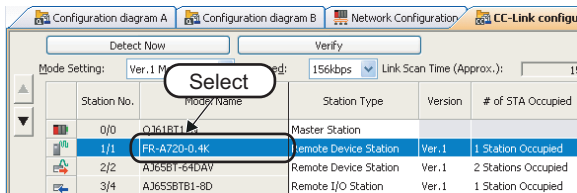

1. Select "Station No." or "Model Name" of the CC-Link module to be deleted.

2. Select [Edit] ⇒ [Delete] in the menu bar to delete CC-Link module.

### 3.4.5 Creating AnyWireASLINK configuration diagrams

Create a configuration by placing modules on the AnyWireASLINK Configuration window.

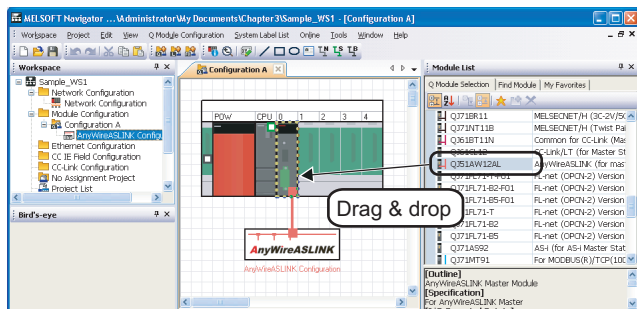

1. Select AnyWireASLINK master module (QJ51AW12AL) from the Module List window, and drag and drop it onto the Module Configuration window.

The AnyWireASLINK configuration diagram is created.

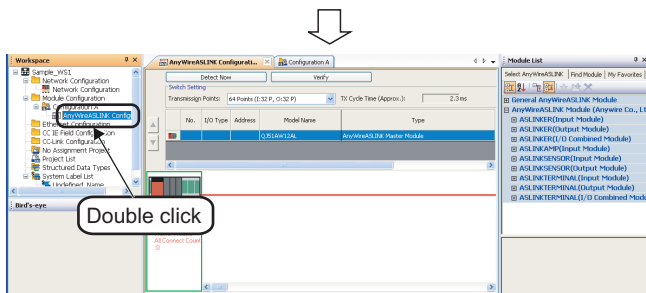

2. Double-click "AnyWireASLINK Configuration" on the Workspace window to open the AnyWireASLINK Configuration window.

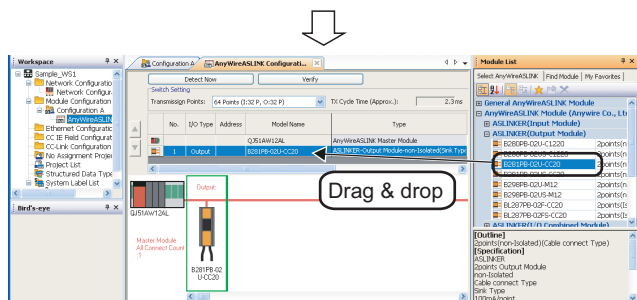

3. Select the AnyWireASLINK slave module (B281PB-02U-CC20) from the Module List window, and drag and drop it onto the AnyWireASLINK Configuration window.

The slave module is added on the "list of modules", and the added slave module is displayed on the "device map area".

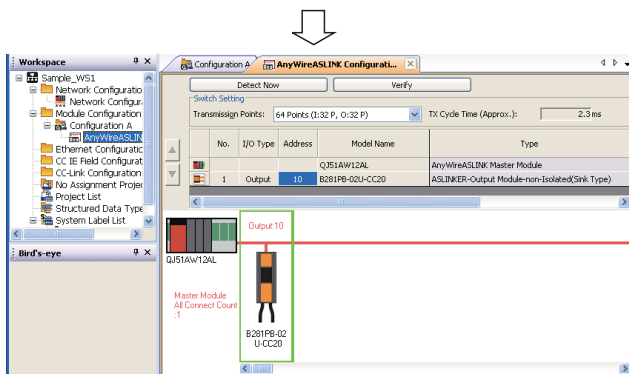

4. Set the address to the added slave module.<sup>\*1</sup>

For the general-purpose AnyWireASLINK module, set the I/O type, address, and number of occupied I/O points.

\*1: The address of the slave module can be set automatically.

For the address auto-input, refer to the following manual.

👉 GX Works2 Version 1 Operating Manual (Intelligent Function Module)

## Point

### ● Detecting actual system configuration

The actual system configuration can be reflected to the AnyWireASLINK Configuration window by performing one of the following operations.

- Click the  button on the AnyWireASLINK Configuration window.
- Select [Online] ⇒ [Detect Now].

For the automatic detection of connected devices, refer to the following manual.

 iQ Sensor Solution Reference Manual

### ● Verifying AnyWireASLINK configuration against the actual system configuration

The AnyWireASLINK configuration can be verified against the actual system configuration by performing one of the following operations.

- Click the  button on the AnyWireASLINK Configuration window.
- Select [Online] ⇒ [Verification of the Configuration with the Connected Module].

For the verification of the configuration with the connected modules, refer to the following manual.

 iQ Sensor Solution Reference Manual

### ● Deleting AnyWireASLINK slave modules

The following shows a method for deleting AnyWireASLINK slave modules from AnyWireASLINK Configuration window.

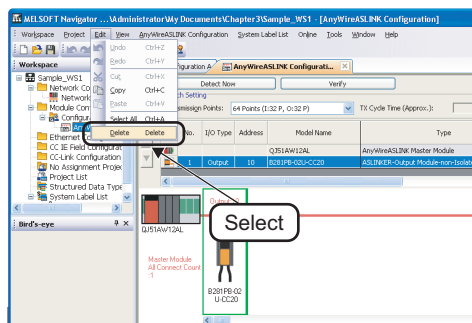
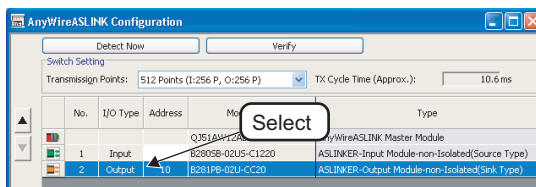

1. Select the row of the AnyWireASLINK slave module to be deleted. (Multiple rows can be selected.)

2. Select [Edit] ⇒ [Delete] in the menu bar to delete AnyWireASLINK slave module.

1 OVERVIEW

2 SCREEN CONFIGURATION

3 OPERATING PROCEDURE OF MELSOFT NAVIGATOR

4 USING SYSTEM LABELS

5 CREATING SYSTEM BACKUP DATA

6 USING PROGRAM JUMP FUNCTION

### 3.4.6 Creating Ethernet configuration diagrams

Create a configuration by placing modules on the Ethernet Configuration window.

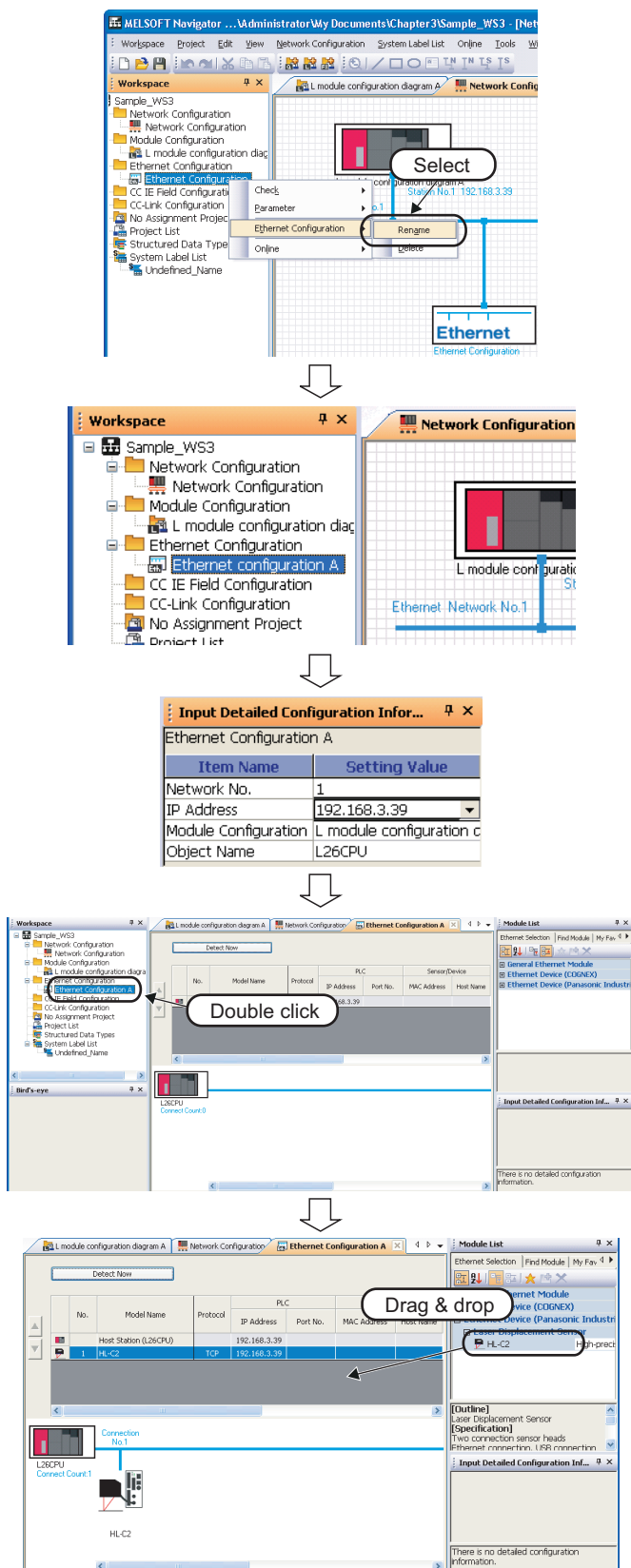

1. Right-click "Ethernet Configuration" on the Workspace window, and select [Ethernet Configuration] ⇒ [Rename] in the shortcut menu.

2. Enter "Ethernet configuration A" to change the Ethernet configuration name.

3. Select an Ethernet built-in CPU to be set as an own station and IP address of Ethernet module.

4. Double-click "Ethernet Configuration" on the Workspace window to open the Ethernet Configuration window.

5. Select an Ethernet device<sup>\*1</sup> from the Module List window, and drag and drop it onto the Ethernet Configuration window.

\*1: For the parameter processing of Ethernet devices, refer to the following manual.



### Point

#### ● Module display on the configuration window

Check that the network modules on the Module Configuration window are connected to the network. If not, the modules are not displayed on the configuration window.

#### ● Detecting actual system configuration

The actual system configuration can be reflected to the Ethernet Configuration window by performing one of the following operations.

- Click the  button on the Ethernet Configuration window.
- Select [Online] ⇒ [Detect Now]

For the automatic detection of connected devices, refer to the following manual.

iQ Sensor Solution Reference Manual

#### ● Reflecting communication settings of Ethernet devices

The communication settings of Ethernet devices can be reflected by performing the following operation.

- Select [Online] ⇒ [Communication Setting Reflection of Ethernet Device]

For the Communication Setting Reflection of Ethernet Device function, refer to the following manual.

iQ Sensor Solution Reference Manual

#### ● Deleting Ethernet devices

The following shows a method for deleting Ethernet devices from Ethernet Configuration window.

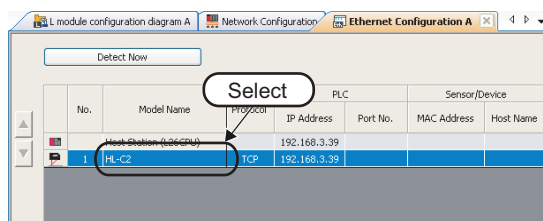

1. Select the row of the Ethernet device to be deleted. (Multiple rows can be selected.)

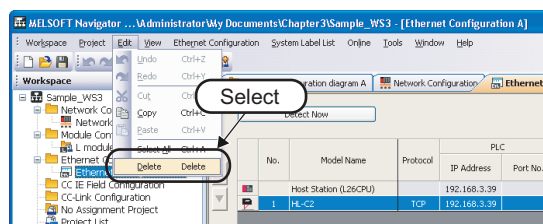

2. Select [Edit] ⇒ [Delete] in the menu bar to delete Ethernet device.

### 3.4.7 Creating CC IE Field configuration diagrams

Create a configuration by placing modules on the CC IE Field Configuration window.

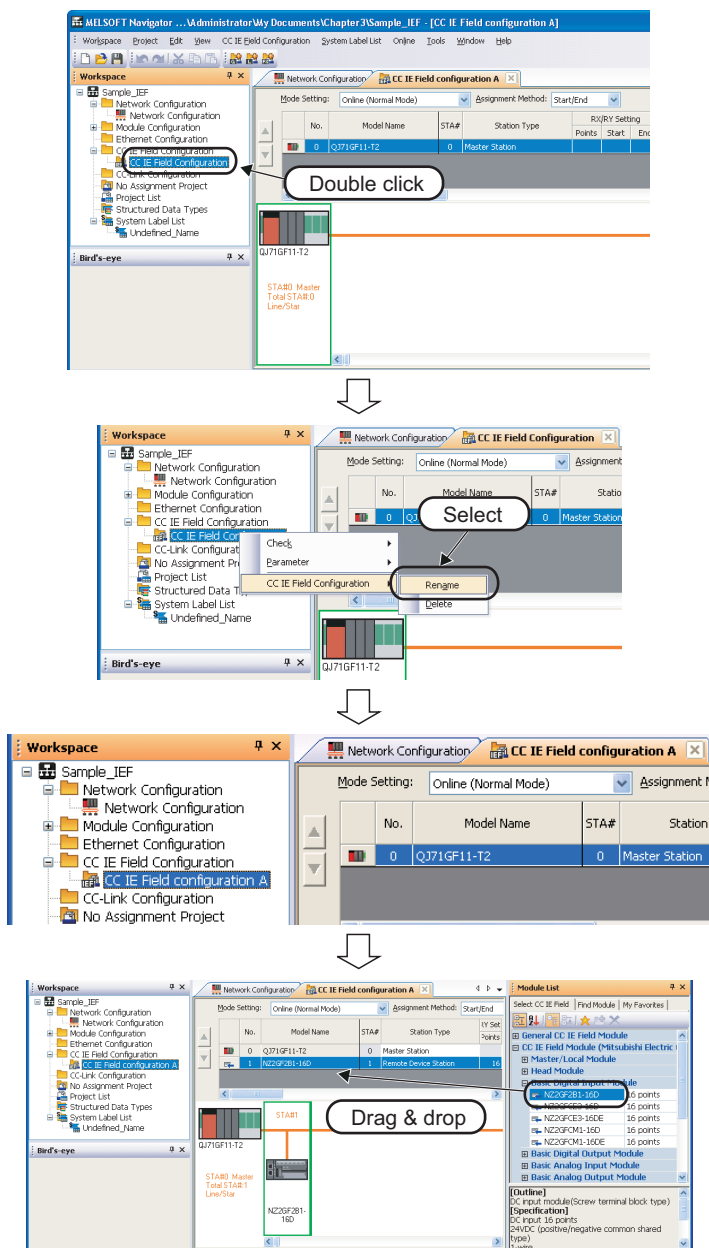

1. Double-click "CC IE Field Configuration" on the Workspace window to open the CC IE Field Configuration window.

CC IE Field configuration diagram<sup>\*1</sup> is created.

2. Right-click "CC IE Field Configuration" on the Workspace window, and select [CC IE Field Configuration] ⇒ [Rename] in the shortcut menu .

3. Enter "CC IE Field configuration A" to change the CC IE Field configuration name.

4. Select a slave station<sup>\*1</sup> from the Module List window, and drag and drop it onto the CC IE Field Configuration window.

\*1: For the parameter processing of slave station, refer to the following manual.

GX Works2 Version 1 Operating Manual (Common)

#### Point

##### ● Module display on configuration window

Check that the network modules on the Module Configuration window are connected to the network. If not, the modules are not displayed on the configuration window.

**Point**

● **Deleting slave stations of CC IE Field**  
The following shows a method for deleting slave stations from CC IE Field Configuration window.

1. Select the row of the slave station to be deleted. (Multiple rows can be selected.)
2. Select [Edit] ⇒ [Delete] in the menu bar to delete the slave station.

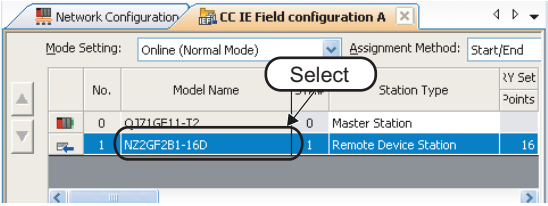

No.	Model Name	Station Type	RY Set Points
0	QJ71GF11-T2	Master Station	
1	NZ2GF2B1-16D	Remote Device Station	16

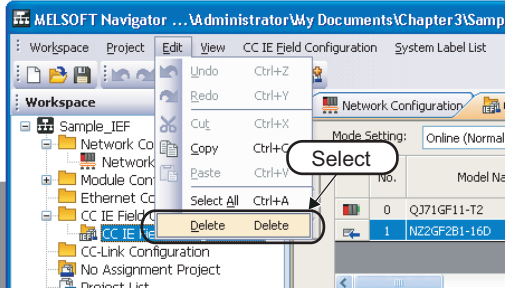

1 OVERVIEW

2 SCREEN CONFIGURATION

3 OPERATING PROCEDURE OF MELSOFT NAVIGATOR

4 USING SYSTEM LABELS

5 CREATING SYSTEM BACKUP DATA

6 USING PROGRAM JUMP FUNCTION

## 3.5 Creating Projects

This section explains the methods for creating project data (programmable controller projects, motion controller projects, GOT projects).

### 3.5.1 Creating new projects

#### ■ Programmable controller projects

Create a new programmable controller project.

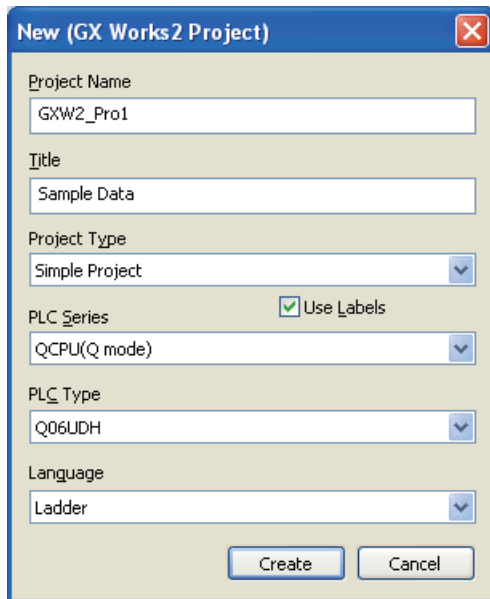
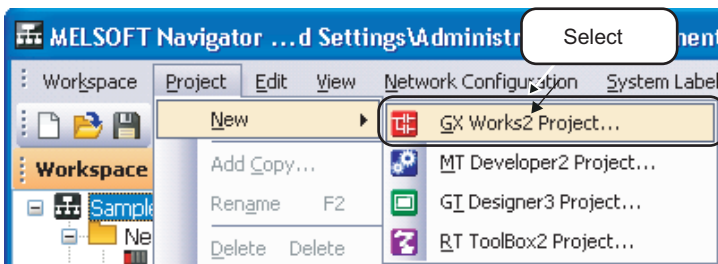

(To the next page)

1. Select [Project] ⇒ [New] ⇒ [GX Works2 Project] in the menu bar to display the "New (GX Works2 Project)" dialog box.

2. Set "Project Name", "Title", "Project Type", "PLC Series", "PLC Type", and "Language" for the new project.

After setting the items, click the  button.

#### Setting example

- Project Name : GXW2\_Pro1
- Title (option) : Sample Data
- Project Type : Simple Project
- Use Labels : Yes
- PLC Series : QCPU (Q mode)
- PLC Type : Q06UDH
- Language : Ladder

(From the previous page)

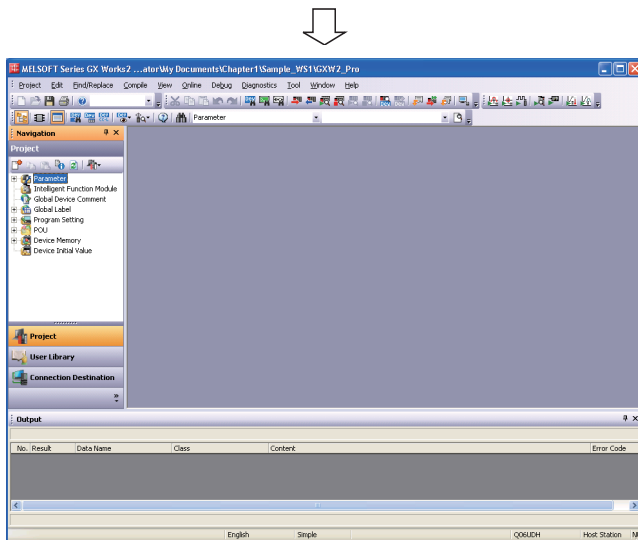
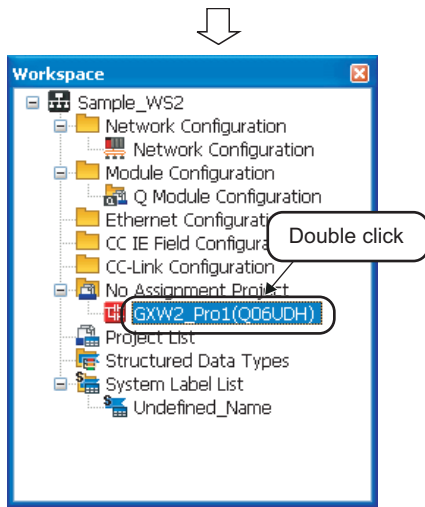

### 3. The new project is created.

Double-click the created project on the Workspace window.

### 4. The programmable controller project is activated.

For editing programmable controller projects, refer to the following manuals.

- ☞ GX Works2 Version 1 Operating Manual (Common)
- ☞ GX Works2 Version 1 Operating Manual (Simple Project)
- ☞ GX Works2 Version 1 Operating Manual (Structured Project)
- ☞ GX Works2 Beginner's Manual (Simple Project)
- ☞ GX Works2 Beginner's Manual (Structured Project)

1  
OVERVIEW2  
SCREEN CONFIGURATION3  
OPERATING PROCEDURE OF MELSOFT NAVIGATOR4  
USING SYSTEM LABELS5  
CREATING SYSTEM BACKUP DATA6  
USING PROGRAM JUMP FUNCTION

## ■ Motion controller projects

Create a new motion controller project.

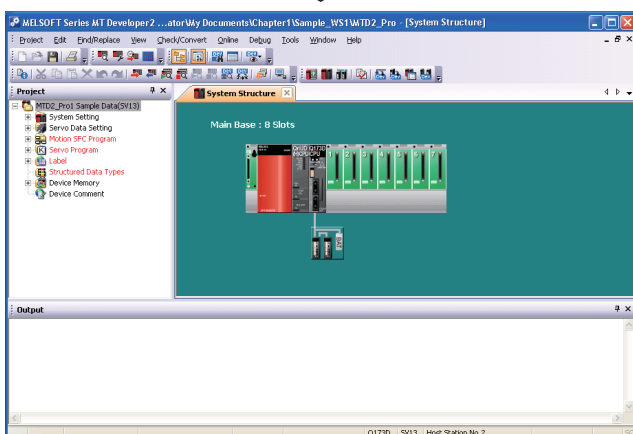
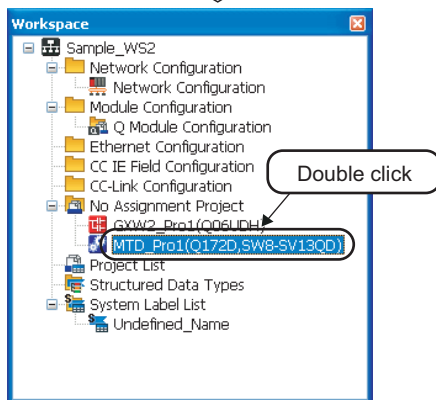
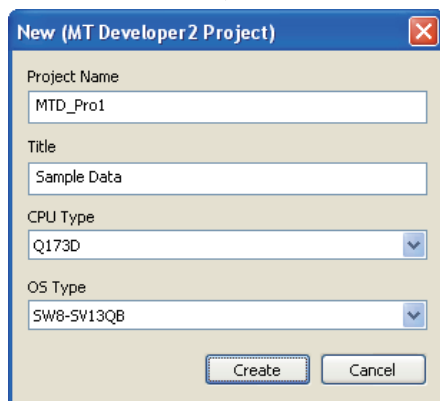
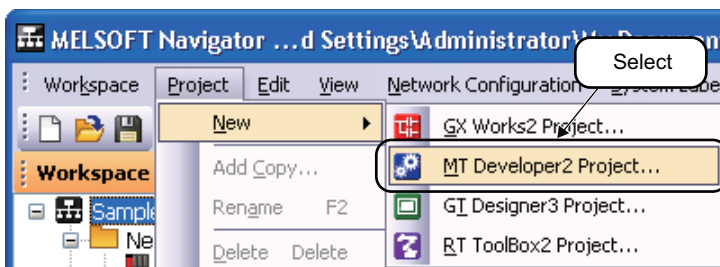

1. Select [Project] ⇒ [New] ⇒ [MT Developer2 Project] in the menu bar to display the "New (MT Developer2 Project)" dialog box.

2. Set "Project Name", "Title", "CPU Type", and "OS Type" for the new project.

After setting the items, click the  button.

### Setting example

- Project Name : MTD2\_Pro1
- Title (option) : Sample Data
- CPU Type : Q173D
- OS Type : SW8-SV13QB

3. The new project is created.

Double-click the created project on the Workspace window.

4. The motion controller project is activated.

For editing motion controller projects, refer to the Help function of MT Developer2.

## ■ GOT projects

Create a new GOT project.

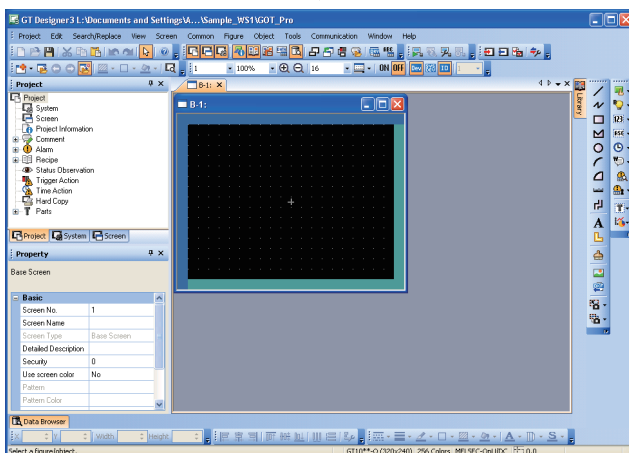
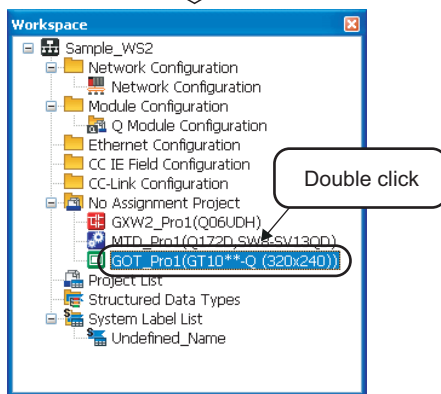
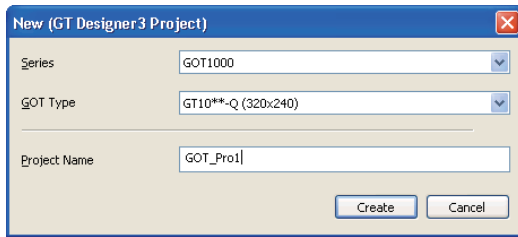
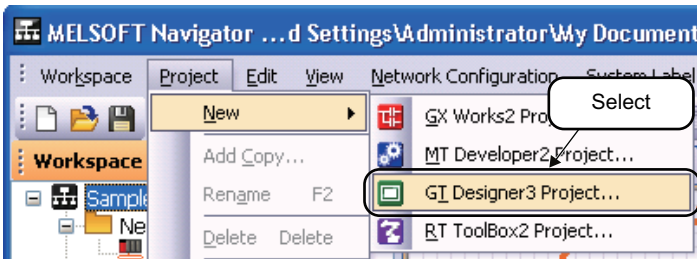

1. Select [Project] ⇒ [New] ⇒ [GT Designer3 Project] in the menu bar to display the "New (GT Designer3 Project)" dialog box.

2. Set "Series", "GOT Type", and "Project Name".

After setting the item, click the  button.

### Setting example

- Series : GOT1000
- GOT Type : GT10\*\*-Q (320 x 240)
- Project Name : GOT\_Pro1

3. The new project is created.

Double-click the created project on the Workspace window.

4. The GOT project is activated.

For editing GOT projects, refer to the following manuals.

- ☞ GT Designer3 Version 1 Screen Design Manual (Fundamentals)
- ☞ GT Designer3 Version 1 Screen Design Manual (Functions)
- ☞ GT Designer3 (GOT2000) Screen Design Manual
- ☞ GT Simulator3 Version 1 Operating Manual
- ☞ GT SoftGOT1000 Version 3 Operating Manual
- ☞ GT SoftGOT2000 Version1 Operating Manual

1 OVERVIEW

2 SCREEN CONFIGURATION

3 OPERATING PROCEDURE OF MELSOFT NAVIGATOR

4 USING SYSTEM LABELS

5 CREATING SYSTEM BACKUP DATA

6 USING PROGRAM JUMP FUNCTION

## Point

## ● Copying projects

The following shows a method for copying a project created in the workspace to create a new project.

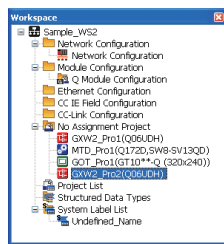
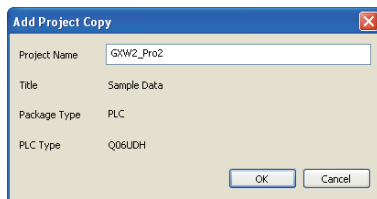
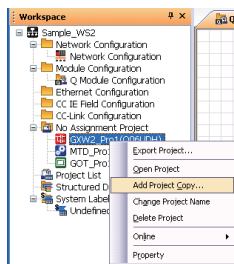

1. Right-click the project name on the Workspace window, and select [Add Project Copy] in the shortcut menu to display the "Add Project Copy" dialog box.

2. Enter a project name for the copied project, and click the  button.

Setting example

- Project Name: GXW2\_Pro2

3. The copied project is displayed in the Workspace window.

## ● Changing project names

The following shows a method for changing a project name of an existing project.

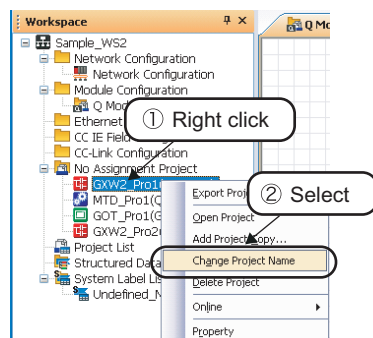

- Right-click the project name on the Workspace window, and select [Change Project Name] in the shortcut menu to change the project name.

## ● Deleting projects

The following shows a method for deleting a project. Once a project is deleted, it cannot be restored again.

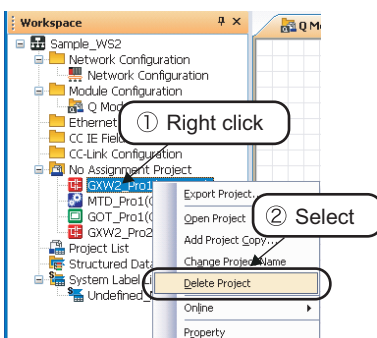

- Right-click the project name on the Workspace window, and select [Delete Project] in the shortcut menu to delete the project.



## 3.5.2 Allocating projects to controllers

Allocate projects in the workspace to controllers on the Module Configuration windows.

### ■ Allocating projects to controllers

The following figure shows controllers with the allocated projects.

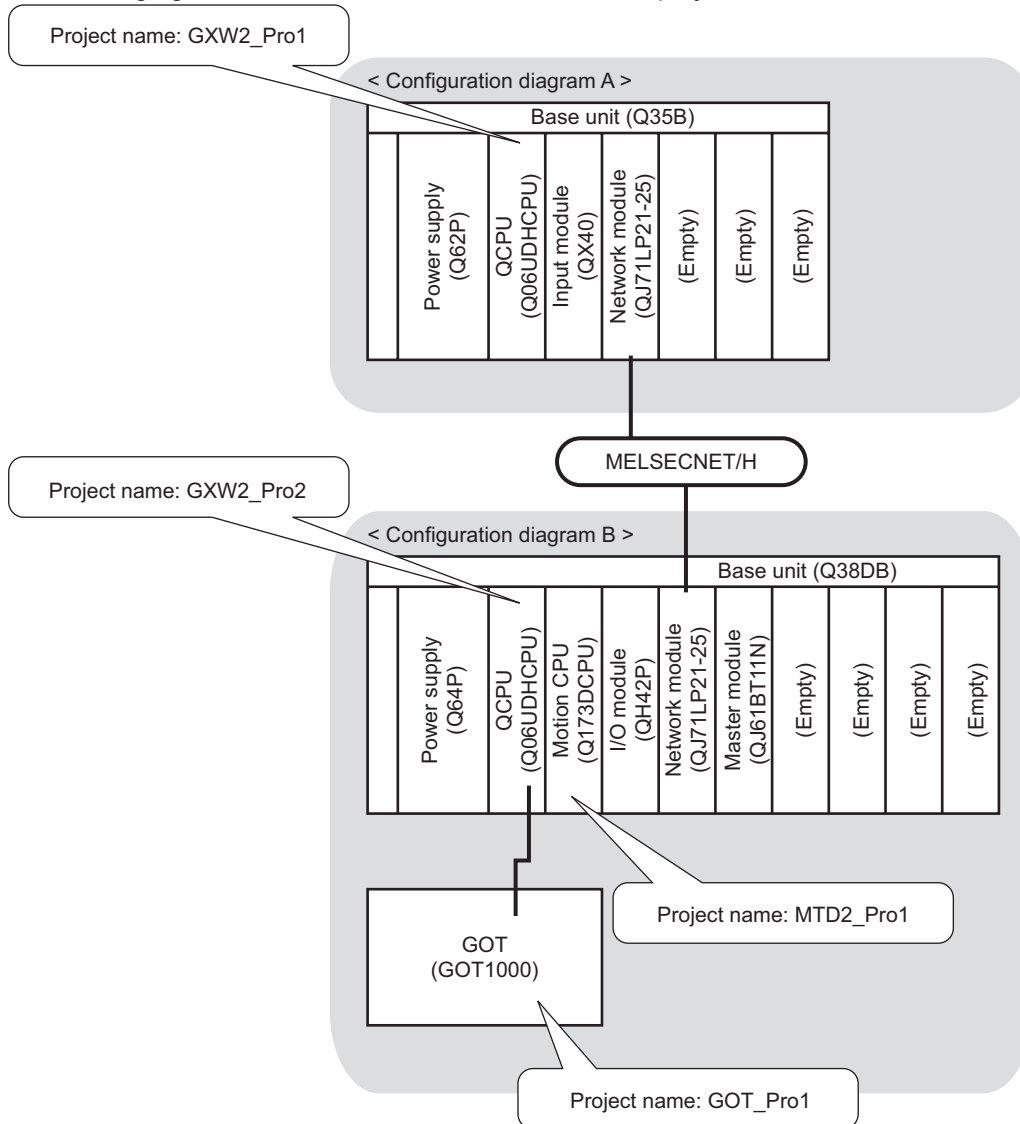

#### Point

##### ● Allocating projects

A project cannot be allocated to a controller if a PLC type or a CPU type of the created project does not match with the module name of the controller.

Check the module name of each controller and allocate projects.

1 OVERVIEW

2 SCREEN CONFIGURATION

3 OPERATING PROCEDURE OF MELSOFT NAVIGATOR

4 USING SYSTEM LABELS

5 CREATING SYSTEM BACKUP DATA

6 USING PROGRAM JUMP FUNCTION

## Batch allocation

Allocate projects in the workspace to all controllers on the Module Configuration windows.

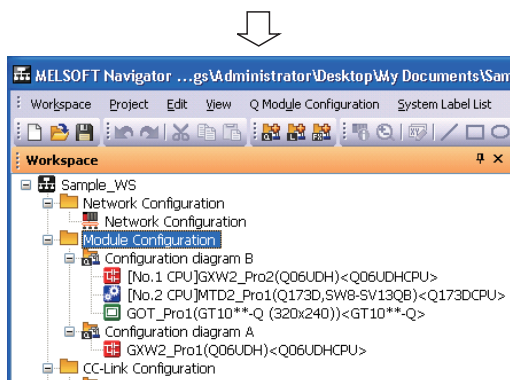
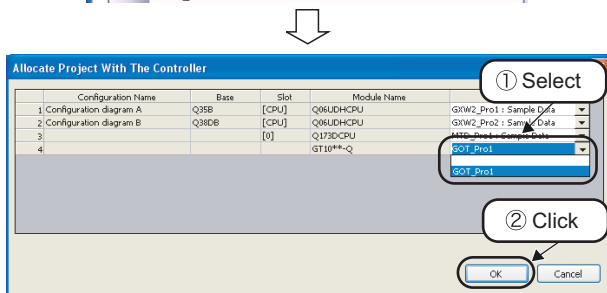
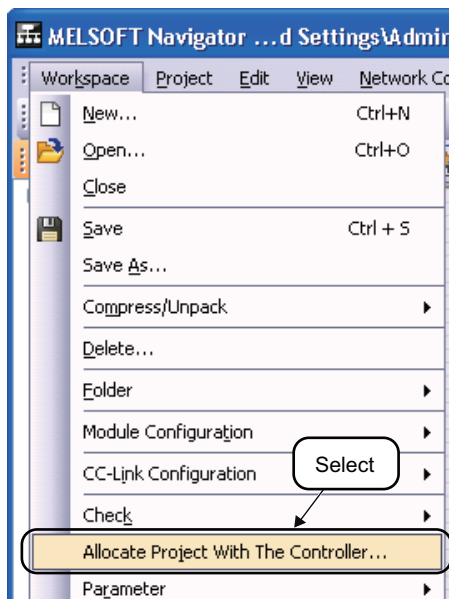

1. Select [Workspace] ⇒ [Allocate Project With The Controller] in the menu bar to display the "Allocate Project With The Controller" dialog box.

2. Select a project name for each controller.  
After selecting the items, click the  button.

### Setting example

Module name	Project name
Q06UDHCPU	GXW2_Pro1: Sample Data
Q06UDHCPU	GXW2_Pro2: Sample Data
Q173DCPU	MTD2_Pro1: Sample Data
GT10**-Q	GOT_Pro1

3. The allocated projects are displayed under the Module Configuration folder on the Workspace window.

## Individual allocation

Allocate a project in the workspace to the controller selected on the Module Configuration window.

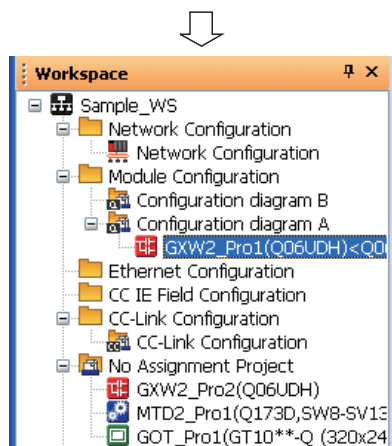
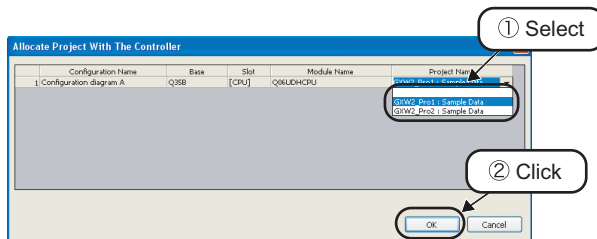
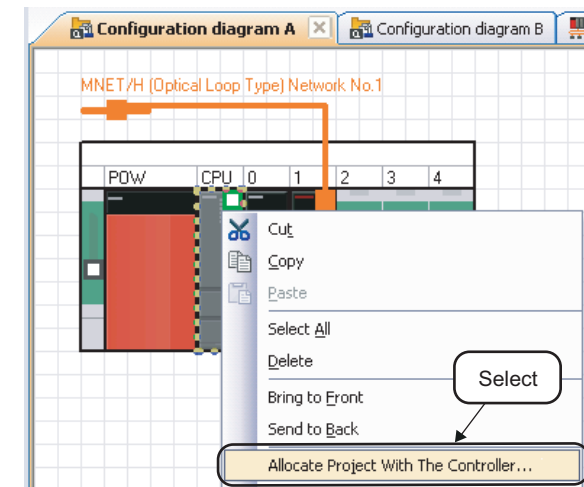

1. Right-click the controller on the Module Configuration window, and select [Allocate Project With The Controller] in the shortcut menu to display the "Allocate Project With The Controller" dialog box.

2. Select a project name for the selected controller. After selecting the item, click the  button.

Setting example

Module name	Project name
Q06UDHCPU	GXW2_Pro1: Sample Data

3. The allocated project is displayed under the Module Configuration folder on the Workspace window.

1 OVERVIEW

2 SCREEN CONFIGURATION

3 OPERATING PROCEDURE OF MELSOFT NAVIGATOR

4 USING SYSTEM LABELS

5 CREATING SYSTEM BACKUP DATA

6 USING PROGRAM JUMP FUNCTION

## 3.6 Setting Parameters

This section explains a method for setting I/O assignment, network parameters, parameters of FX series special adapters, and multiple CPU parameters for project data (programmable controller project, motion controller project, GOT project).

### ■ Setting I/O assignment

I/O assignment for each controller can be set without opening respective parameter setting dialog boxes.

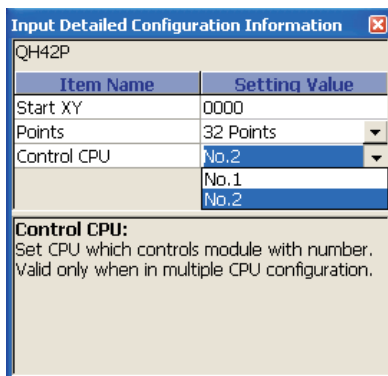
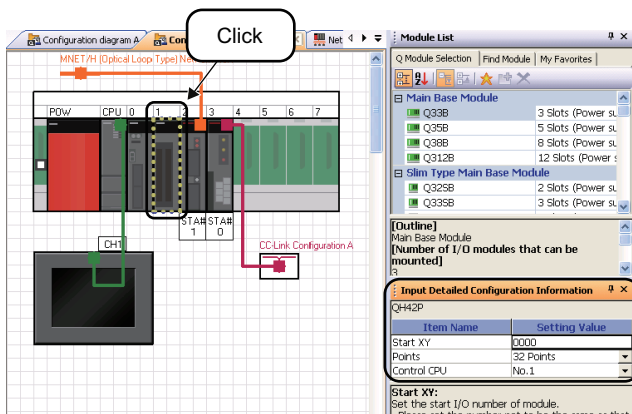

1. Click the module on "Configuration diagram B".

The parameters are displayed on the Input Detailed Configuration Information window.

2. Set the parameters on the Input Detailed Configuration Information window.

#### Setting example

- Start XY : 0000
- Points : 32 points
- Control CPU : CPU No. 2

For setting parameters, refer to user's manuals of each CPU.

## Setting network parameters

Network parameters for each controller can be set without opening respective parameter setting dialog boxes.

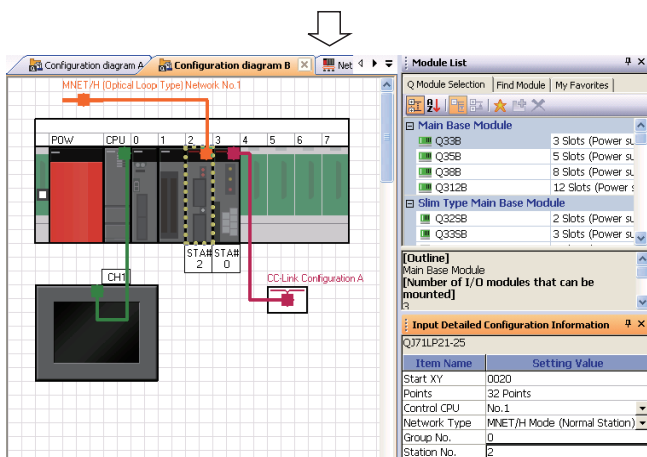
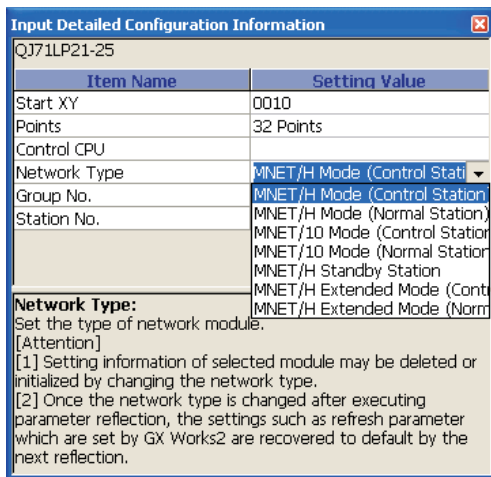
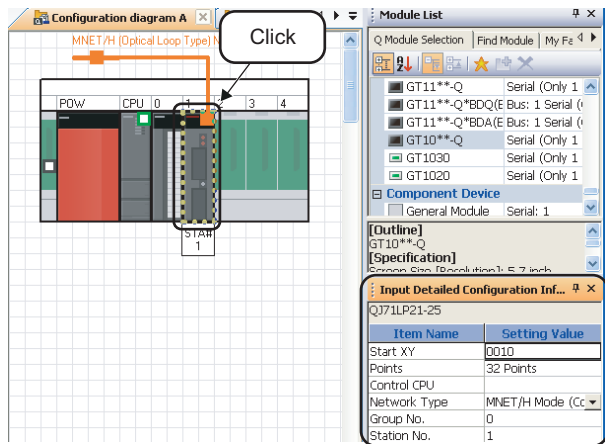

1. Click the network module (QJ71LP21-25) on "Configuration diagram A".

The parameters are displayed on the Input Detailed Configuration Information window.

2. Set the parameters on the Input Detailed Configuration Information window.

### Setting example

- Start XY : 0010
- Points : 32 Points
- Control CPU : -
- Network Type : MNET/H Mode (Control Station)
- Group No. : 0
- Station No. : 1

3. Set the parameters for "Configuration diagram B" following the same procedure in the step 1 and step 2.

### Setting example

- Start XY : 0020
- Points : 32 Points
- Control CPU : No. 1
- Network Type : MNET/H Mode (Normal Station)
- Group No. : 0
- Station No. : 2

For setting parameters, refer to user's manuals of each CPU.

## Setting parameters of FX series special adapter

The parameters of special adapters can be set without opening the parameter setting screen of programmable controller project. The following shows an example when using FX3U-ENET-ADP.

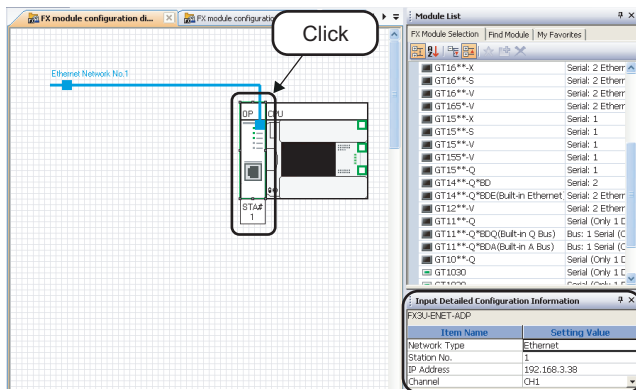

1. Click "FX3U-ENET-ADP" on "FX module configuration diagram A".

The parameters are displayed on the Input Detailed Configuration Information window.

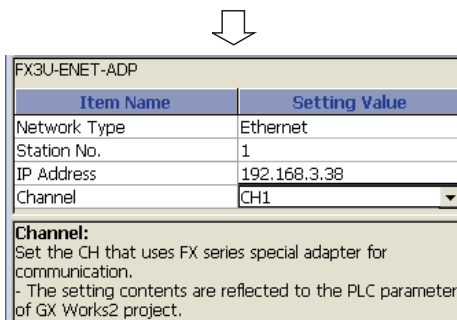

2. Set the parameters on the Input Detailed Configuration Information window.

### Setting example

- Station number: 1
- IP address : 192.168.3.38
- Channel : CH1

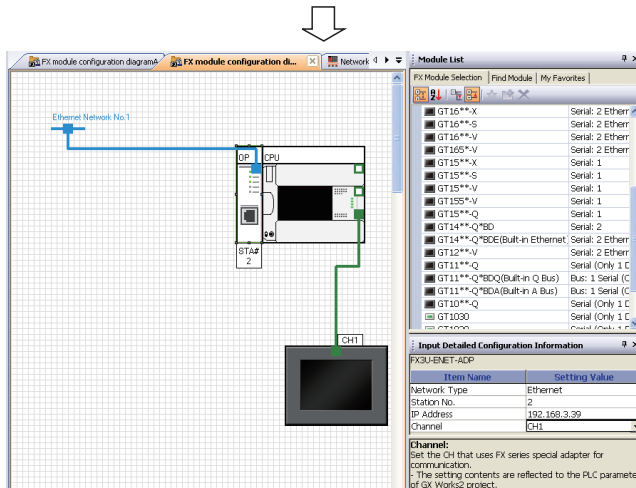

3. Set the parameters of "FX module configuration diagram B" following the same procedure in the step 1 and step 2.

### Setting example

- Station number: 2
- IP address : 192.168.3.39
- Channel : CH1

For the reflection method for the set parameters to a programmable controller project, refer to the following section.

➡ ■ Reflecting parameters to projects

### Point

#### ● Parameter initialization

When "Channel" has already been set to <<PLC System (2)>> tab of PLC parameter in the target program, the settings of <<PLC System (2)>> tab will be initialized.

To retain the settings in the programmable controller project, backup the project before reflecting the parameters.

## ■ Reflecting parameters to projects

Reflect parameters set in MELSOFT Navigator to projects.

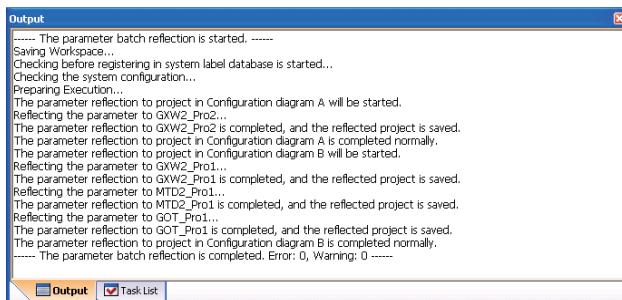
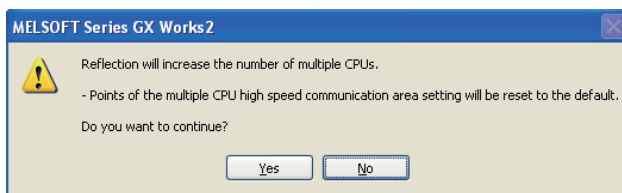
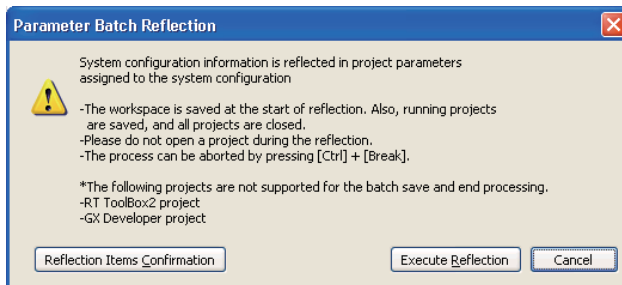
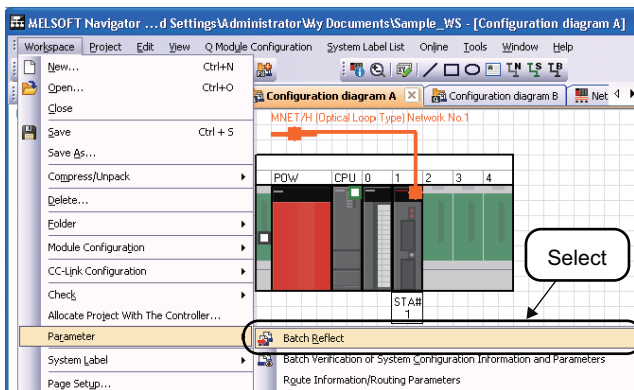

1. Select [Workspace] ⇒ [Parameter] ⇒ [Batch Reflect] in the menu bar.

2. The message shown on the left is displayed.

Read the message and click the  button.

3. The message shown on the left is displayed.

Read the message and click the  button.

4. The parameters are reflected to the projects.

Error or Warning is displayed when the reflection result contains an error. Check the error description on the Task List window and correct the error.

1 OVERVIEW

2 SCREEN CONFIGURATION

3 OPERATING PROCEDURE OF MELSOFT NAVIGATOR

4 USING SYSTEM LABELS

5 CREATING SYSTEM BACKUP DATA

6 USING PROGRAM JUMP FUNCTION

## ■ Setting multiple CPU parameters

Set multiple CPU parameters by activating the multiple CPU settings of each controller project from MELSOFT Navigator. Set the parameters on CPU No. 1, and utilize them for CPU No. 2.

The following is an example when utilizing parameters of programmable controller project for a motion controller project.

For setting parameters on a motion controller project, follow the same procedure as described below.

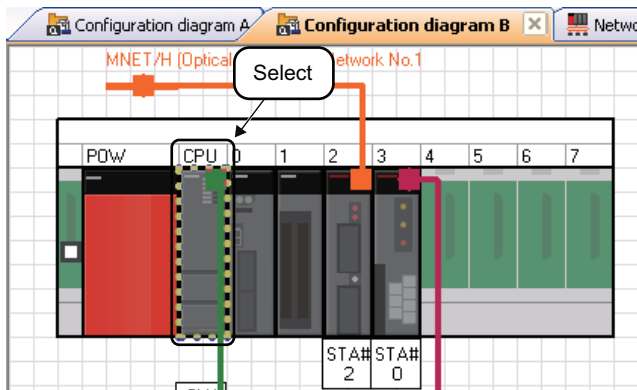

1. Select the CPU No. 1 controller on the Module Configuration window.

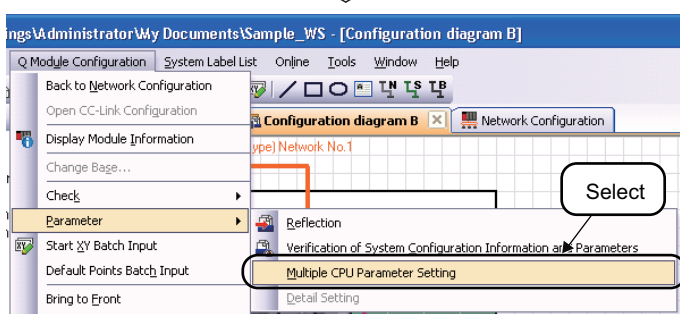

2. Select [Q Module Configuration] ⇒ [Parameter] ⇒ [Multiple CPU Parameter Setting] in the menu bar.

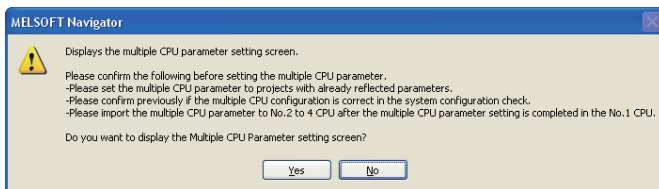

3. The message shown on the left is displayed.

Read the message and click the  button.

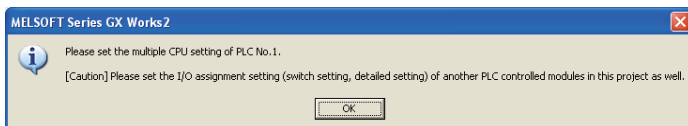

4. GX Works2 is activated and the message shown on the left is displayed.

Read the message and click the  button.

(To the next page)



(From the previous page)

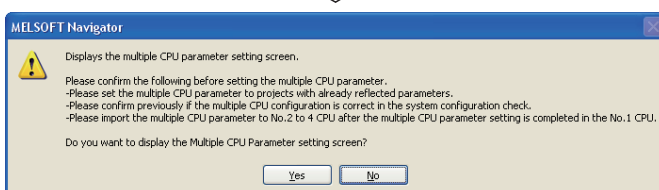
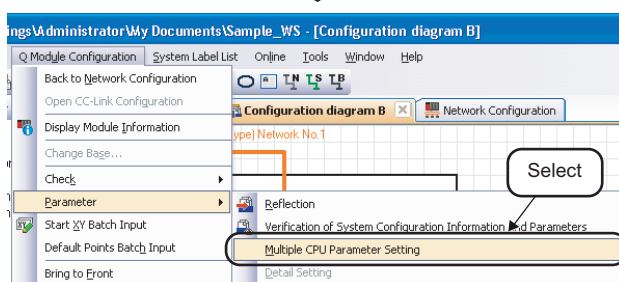
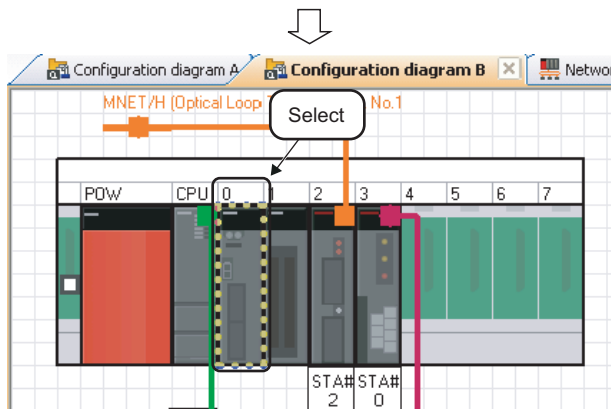
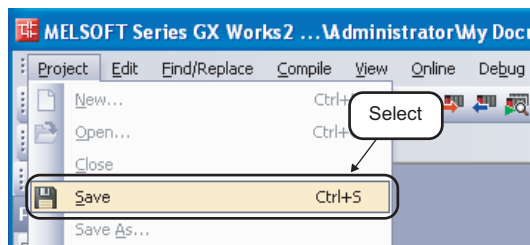
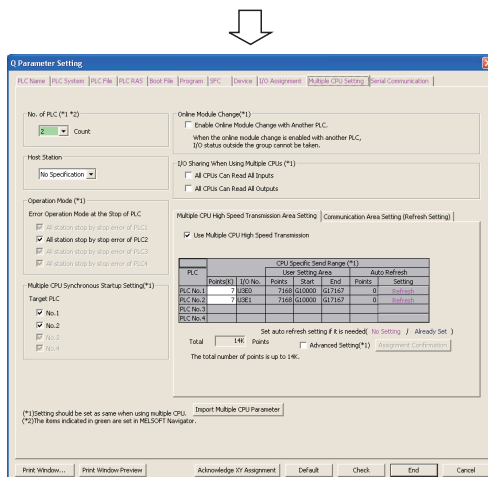

(To the next page)

- The "Q Parameter Setting" dialog box is displayed.

For setting multiple CPU parameters, refer to the following manual and function.

☞ QCPU User's Manual (Multiple CPU System)

☞ Help function of MT Developer2

- Select [Project] ⇒ [Save] in the menu bar of GX Works2.

- Select the CPU No. 2 controller on the Module Configuration window

- Select [Q Module Configuration] ⇒ [Parameter] ⇒ [Multiple CPU Parameter Setting] in the menu bar.

- The message shown on the left is displayed.

Read the message and click the  button.

1 OVERVIEW

2 SCREEN CONFIGURATION

3 OPERATING PROCEDURE OF MELSOFT NAVIGATOR

4 USING SYSTEM LABELS

5 CREATING SYSTEM BACKUP DATA

6 USING PROGRAM JUMP FUNCTION

(From the previous page)

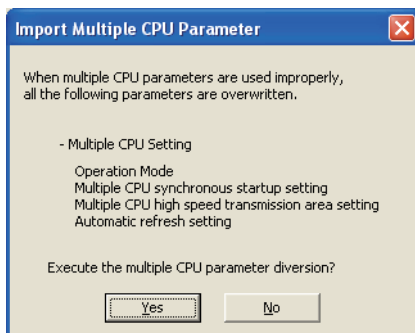
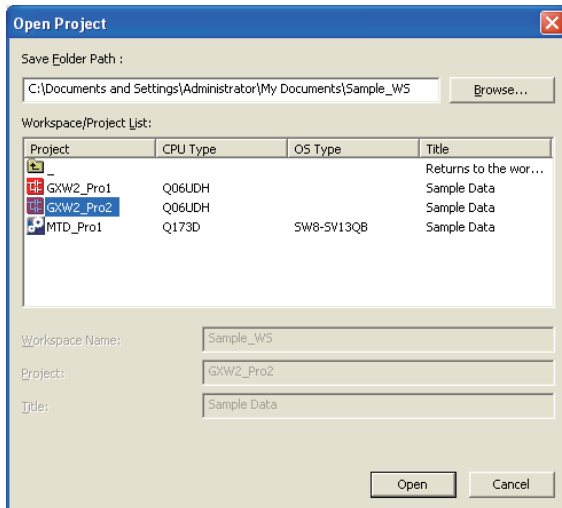
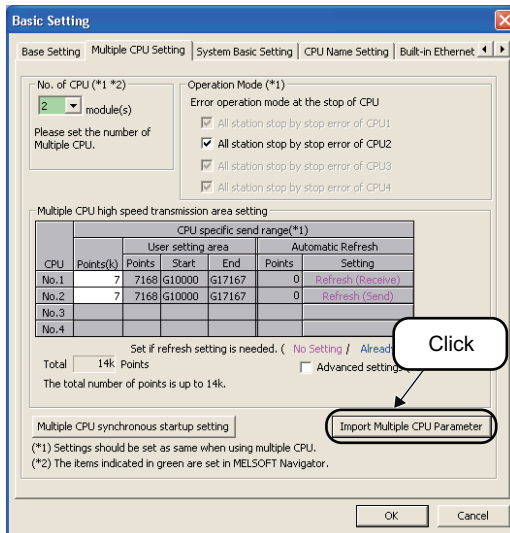
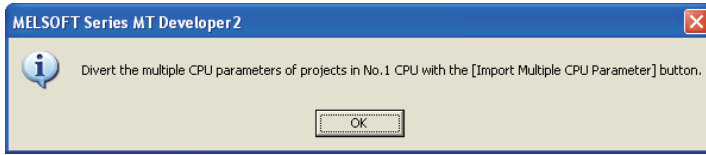

10. MT Developer2 is activated and the message shown on the left is displayed.

Read the message and click the  button.

11. The "Basic Setting" dialog box is displayed.

Click the  button to display the "Open Project" dialog box.

12. Check that the project name allocated to the CPU No. 1 is selected, and click the  button.

13. The message shown on the left is displayed.

Read the message and click the  button to utilize the multiple CPU parameter of CPU No.1 for CPU No. 2.



1
OVERVIEW
2
SCREEN CONFIGURATION
3
OPERATING PROCEDURE OF MELSOFT NAVIGATOR
4
USING SYSTEM LABELS
5
CREATING SYSTEM BACKUP DATA
6
USING PROGRAM JUMP FUNCTION

● **Verifying system configuration information with parameters**  
 After parameters are reflected to projects, check for differences between parameters (system configuration information) set in MELSOFT Navigator and parameters of project assigned to each controller.

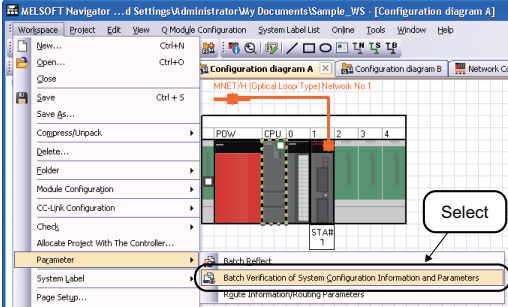

1. Select [Workspace] ⇒ [Parameter] ⇒ [Batch Verification of System Configuration Information and Parameters] in the menu bar.

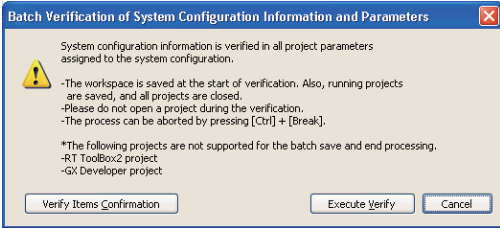

2. The message shown on the left is displayed.  
 Read the message and click the  button.

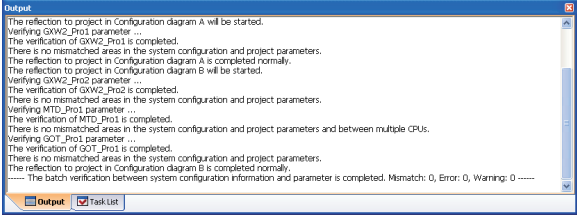

3. The verification is executed.  
 Error or Warning is displayed when the verification result contains an error. Check the error description on the Task List window and correct the error.

### Point

#### ● Setting start XY in batch

Assign start XY consecutively to modules or empty slots in the order of slot number.

Resetting of start XY to each module is no longer required when replacing modules or changing number of points.

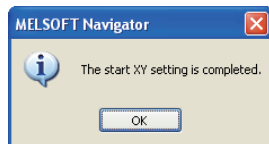
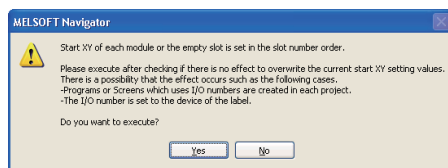
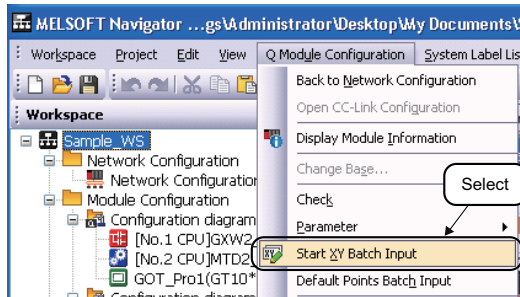

1. Select [Q Module Configuration] ⇒ [Start XY Batch Input] in the menu bar.

2. The message shown on the left is displayed.

Read the message and click the  button.

3. The message on the left is displayed, and start XY is set.

Click the  button to complete the start XY setting.

#### ● Setting default points in batch

Set default to all points of modules or empty slots on the base unit.

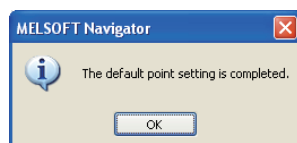
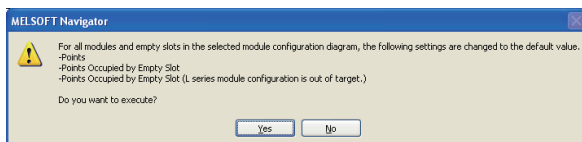
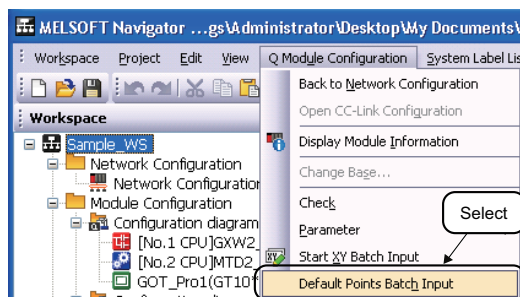

1. Select [Q Module Configuration] ⇒ [Default Points Batch Input] in the menu bar.

2. The message shown on the left is displayed.

Read the message and click the  button.

3. The message shown on the left is displayed, and default points are set.

Click the  button to complete the default point setting.

## 3.7 Checking System Configuration

This section explains a method for checking module configurations/CC-Link configurations of created system configuration, power supply capacity, and I/O points.

### 3.7.1 Checking system configuration

Check module configurations of created system configuration and allocated status of projects.

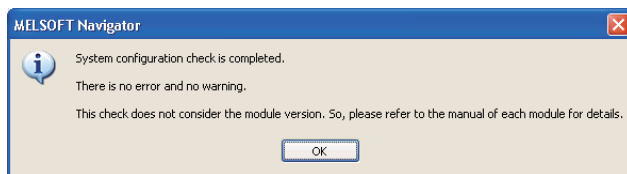
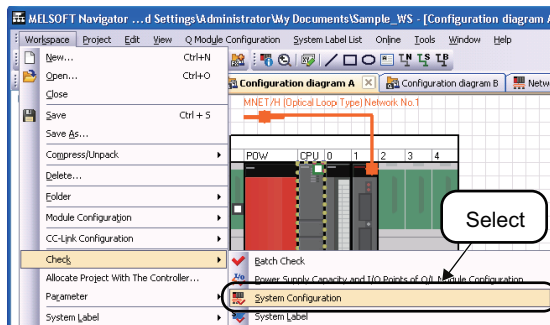

1. Select [Workspace] ⇒ [Check] ⇒ [System Configuration] in the menu bar.

2. The message shown on the left is displayed.

Read the message and click the  button.

Error or Warning is displayed when the check result contains an error. Check the error description on the Task List window and correct the error.

#### Point

##### ● Check target

System configuration check function checks the following items.

- Common to Q series/L series/FX series module configurations
  - Unmounted modules
  - Matching of project PLC type and CPU module model name of module configuration.
  - Allocation of projects in the workspace to CPU modules or other modules of module configuration.
- Q series module configuration
  - Power supply mounting condition
  - CPU module configuration (multiple CPU system)
  - Configuration of main base unit and extension base unit or GOT
  - Number of mounted modules (For details, refer to the Help function of MELSOFT Navigator.)
  - Consumption current within the range
  - I/O points within the range
- L series module configuration
  - Power supply and END cover mounting condition
  - Consumption current within the range
  - I/O points within the range
- AnyWireASLINK configuration, CC-Link configuration, Ethernet configuration, and CC IE Field configuration
- Equipment configuration of AnyWireASLINK configuration, CC-Link configuration, Ethernet configuration, and CC IE Field configuration

Note that, CPU module versions, module versions, and GOT model names are not checked.

##### ● GOT installation

When installing the first GOT at the position more than 13.2m in distance, a bus extension connector box is required.

### 3.7.2 Checking power supply capacity and I/O points

Check power supply capacity and I/O points of created system configuration.  
This functions is not supported by FXCPU.

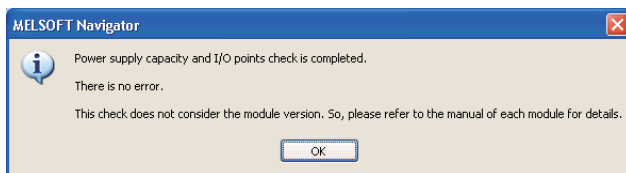
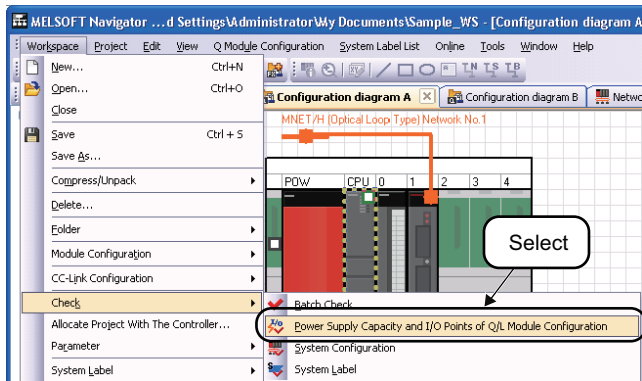

1. Select [Workspace] ⇒ [Check] ⇒ [Power Supply Capacity and I/O Points of Q/L Module Configuration] in the menu bar.

2. The message shown on the left is displayed.

Read the message and click the  button to display the "Result of Power Supply Capacity and I/O Points Check" window.

3. Check for errors in the check result.

When an error exists in the check result (items displayed in red), options of modules for re-selection are displayed by clicking "Total Output Current" or "Total I/O Points". A message is displayed by clicking "Total Voltage Drop". Read the message and correct the module configurations.

Module Configuration Diagram	Base/Cable	Slot	Module Name	Consumption Current	Total Output Current	Total Voltage Drop	Total I/O Points
Configuration diagram A	Q30B	-	Q30B	0.114A	1.1A / 3A	-	96 Points / 4096 Points
2		[Power Supply]	Q62P	-	-	-	-
3		[CPU]	Q06UHCPU	0.39A	-	-	-
4		[I]	Q340	0.05A	-	-	-
5		[I]	Q371LP21-2S	0.35A	-	-	-
6	Configuration diagram B	Q300B	Q300B	0.23A	2.55A / 3A	-	344 Points / 4096 Points
7		[Power Supply]	Q62P	-	-	-	-
8		[CPU]	Q06UHCPU	0.39A	-	-	-
9		[I]	Q1730-CPU	1.25A	-	-	-
10		[I]	Q442P	0.13A	-	-	-
11		[I]	Q371LP21-2S	0.35A	-	-	-

#### Point

##### ● "Total Output Current"

Values displayed under "Total Output Current" may be different from the total output current of module with latest version.

For the total output current of module with latest version, check the latest manuals of each module.

## 3.8 Editing Projects

This section explains a method for editing created projects and utilizing them for other workspace.

### 3.8.1 Editing projects

Activate the created project for editing.

The following is an example of activating a programmable controller project.

For activating a motion controller project or a GOT project, follow the same procedure as described below.

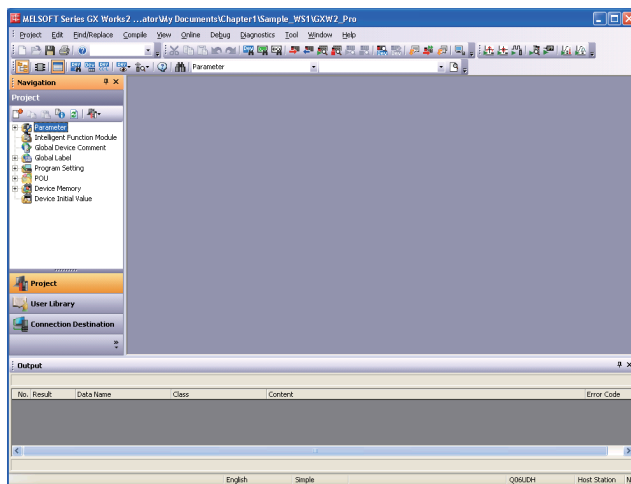
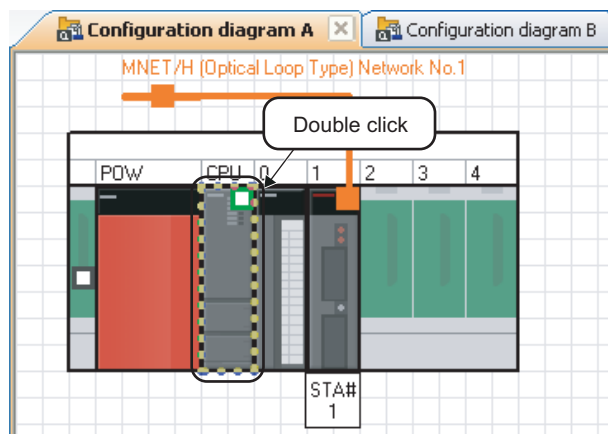

1. On the Module Configuration window, double-click the controller to which a programmable controller project is allocated.

2. The programmable controller project is activated.

For editing programmable controller projects, refer to the following manuals.

- ☞ GX Works2 Version 1 Operating Manual (Common)
- ☞ GX Works2 Version 1 Operating Manual (Simple Project)
- ☞ GX Works2 Version 1 Operating Manual (Structured Project)
- ☞ GX Works2 Beginner's Manual (Simple Project)
- ☞ GX Works2 Beginner's Manual (Structured Project)

#### Point

- **Activating projects**

Projects can also be activated from the Workspace window or Project List window.

- **Activating the related software**

The related software is activated by double-clicking the module on the FX Series Module Configuration window.

### 3.8.2 Utilizing existing projects (import)

Utilize a project created in other workspace using MELSOFT Navigator.

#### Point

##### ● Importing projects

Projects created using engineering software products (GX Works2, MT Developer2, GT Designer3, and RT ToolBox2) and GX Developer can be imported to the workspace created using MELSOFT Navigator.

##### ● Importing GX Developer projects

GX Developer projects are converted to GX Works2 format and imported to MELSOFT Navigator. However, depending on the programmable controller type, some projects are not supported for import, or not converted to GX Works2 format.

For details, refer to the Help function of MELSOFT Navigator.

In addition, a project imported in GX Developer format cannot be allocated to a controller etc. on the module configuration window.

The following operation is an example of utilizing a GX Works2 project.

For utilizing MT Developer2 or GT Designer3 projects, follow the same procedure as described below.

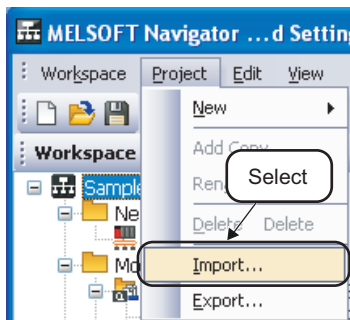

1. Select [Project] ⇒ [Import] in the menu bar to display the "Import" dialog box.

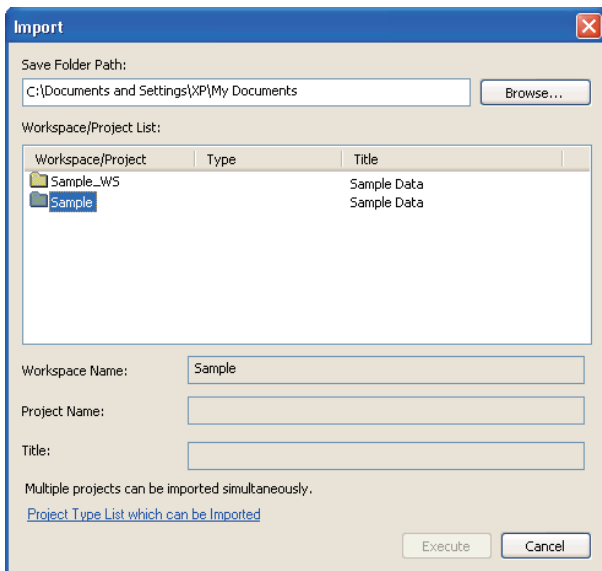

2. Set "Save Folder Path" for the project to be utilized, and double-click the workspace name of the project to be imported.

#### Setting example

- Save Folder Path : C:\Documents and Settings\Administrator\My Documents
- Workspace : Sample

(To the next page)



(From the previous page)

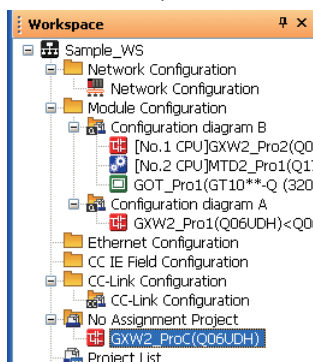
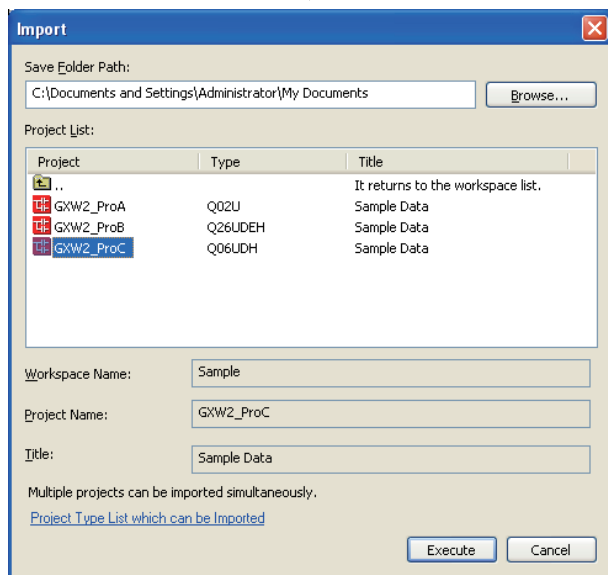

3. Selecting the workspace displays the list of GX Works2 projects.

Select the project to be utilized, and click the **Execute** button.

#### Setting example

- Project Name: GXW2\_ProC

4. The project is imported in the Workspace window.

1 OVERVIEW

2 SCREEN CONFIGURATION

3 OPERATING PROCEDURE OF MELSOFT NAVIGATOR

4 USING SYSTEM LABELS

5 CREATING SYSTEM BACKUP DATA

6 USING PROGRAM JUMP FUNCTION

### Point

#### ● Importing projects

Projects in several workspaces can be organized into one workspace.  
For details, refer to the Help function of MELSOFT Navigator.

#### ● Exporting projects

Export projects of an open workspace, and add them to a new or existing workspace by following the procedure below.

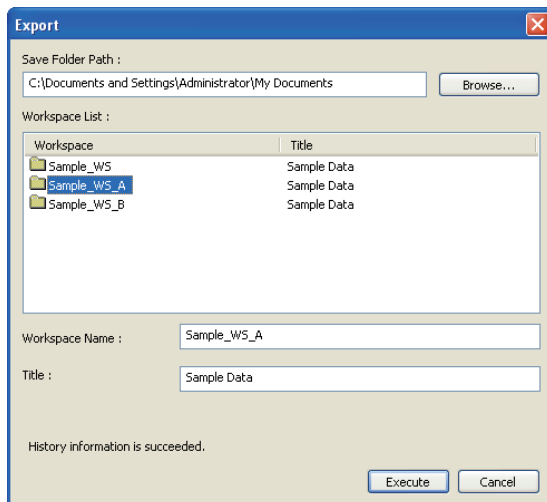
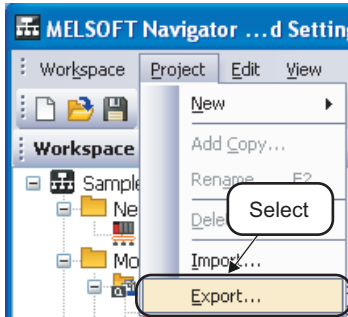

1. Select [Project] ⇒ [Export] in the menu bar to display the "Export" dialog box.

2. Set "Save Folder Path" and "Workspace" for the project to be saved.

Click the  button to export the workspace.

#### Setting example

- Save Folder Path : C:\Documents and Settings\Administrator\My Documents
- Workspace : Sample\_WS\_A

## 3.9 Reading/Writing/Verifying Controller Data

This section explains a method for reading/writing/verifying project data (programmable controller project, motion controller project, GOT project).

### ■ Programmable controller projects

Read/write/verify programmable controller project data.

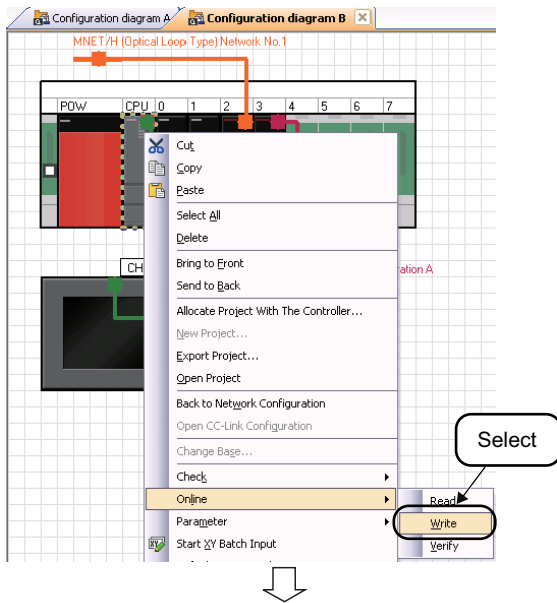

1. On the System Configuration window, right-click the controller to which a programmable controller project is allocated, and select [Online] ⇒ [Read]/[Write]/[Verify] in the shortcut menu.

The screen image on the left shows the case when [Write] is selected. Perform the same operation for [Read] and [Verify].

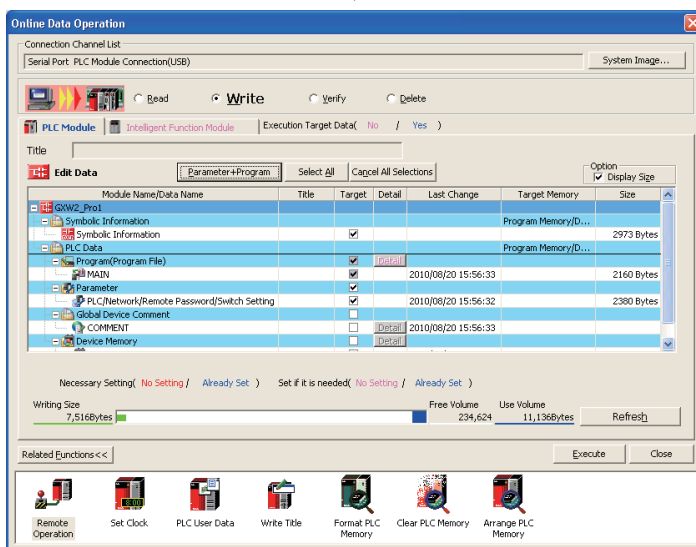

2. The "Online Data Operation" dialog box is displayed.

For operating the "Online Data Operation" dialog box, refer to the following manuals.

- GX Works2 Version 1 Operating Manual (Common)
- GX Works2 Version 1 Operating Manual (Simple Project)
- GX Works2 Version 1 Operating Manual (Structured Project)
- GX Works2 Beginner's Manual (Simple Project)
- GX Works2 Beginner's Manual (Structured Project)

## ■ Motion controller projects

Read/write/verify motion controller project data.

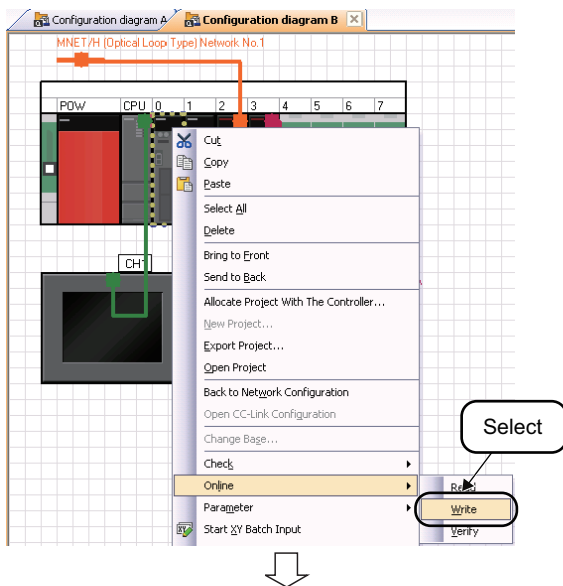

1. On the System Configuration window, right-click the controller to which a motion controller project is allocated, and select [Online] ⇒ [Read]/[Write]/[Verify] in the shortcut menu.

The screen image on the left shows the case when [Write] is selected. Perform the same operation for [Read] and [Verify].

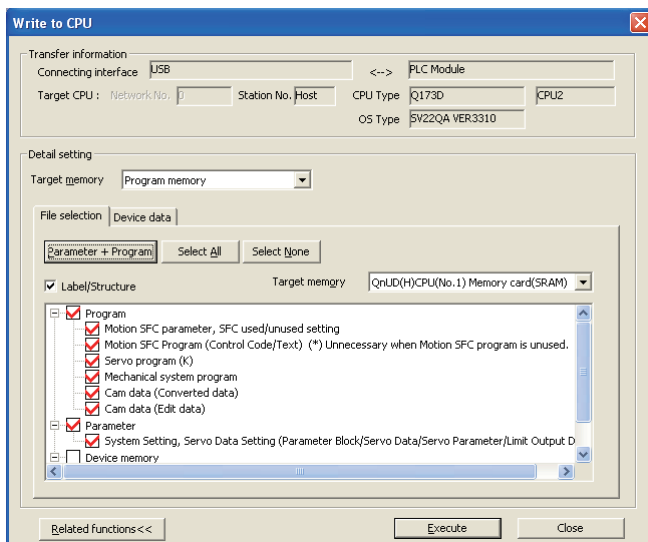

2. The "Write to CPU" dialog box is displayed.

For operating the "Read from CPU", "Write to CPU", and "Verify with CPU" dialog boxes, refer to the Help function of MT Developer2.

## ■ GOT projects

Read/write/verify GOT project data.

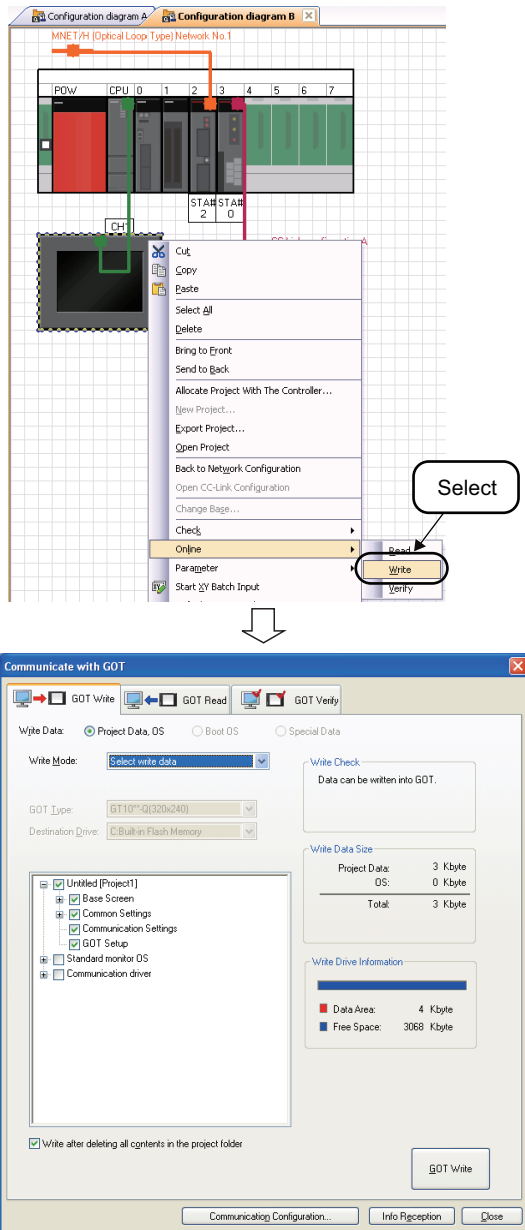

1. On the System Configuration window, right-click the controller to which a GOT project is allocated, and select [Online] ⇒ [Read]/[Write]/[Verify] in the shortcut menu.

The screen image on the left shows the case when [Write] is selected. Perform the same operation for [Read] and [Verify].

2. The "Communicate with GOT" dialog box is displayed.

For operating the "Communicate with GOT" dialog box, refer to the following manuals.

- GT Designer3 Version 1 Screen Design Manual (Fundamentals)
- GT Designer3 (GOT2000) Screen Design Manual
- Connection manuals for GOT1000 series (Mitsubishi Products), (Non-Mitsubishi Products 1), (Non-Mitsubishi Products 2), (Microcomputer, MODBUS Products, Peripherals)
- Connection manuals for GOT2000 series (Mitsubishi Products), (Non-Mitsubishi Products 1), (Non-Mitsubishi Products 2), (Microcomputer, MODBUS Products, Peripherals)
- GT Simulator3 Version 1 Operating Manual
- GT SoftGOT1000 Version 3 Operating Manual
- GT SoftGOT2000 Version1 Operating Manual

1 OVERVIEW

2 SCREEN CONFIGURATION

3 OPERATING PROCEDURE OF MELSOF NAVIGATOR

4 USING SYSTEM LABELS

5 CREATING SYSTEM BACKUP DATA

6 USING PROGRAM JUMP FUNCTION

## 3.10 Saving Workspaces

This section explains a method for saving created workspaces.

### 3.10.1 Saving workspaces with specified names

Save an open workspace with a specified name.

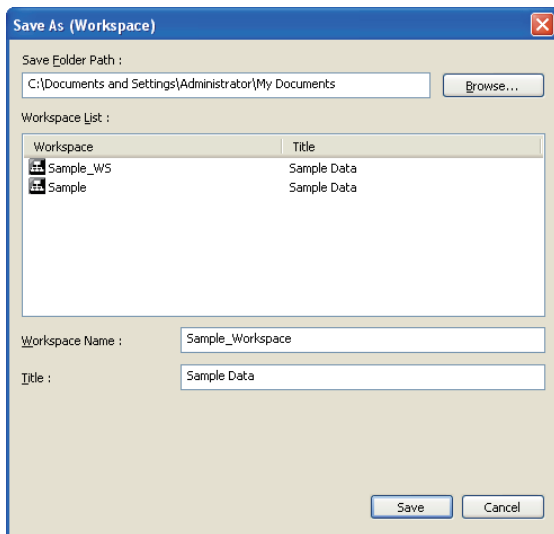
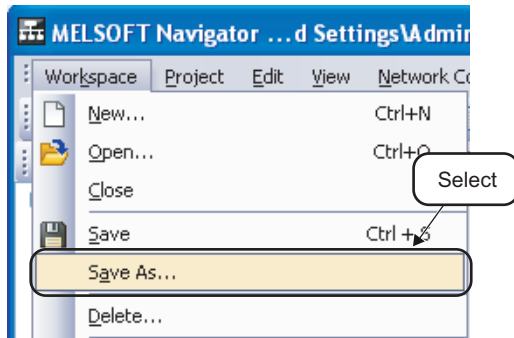

1. Select [Workspace] ⇒ [Save As] in the menu bar to display the "Save As (Workspace)" dialog box.

2. Set "Save Folder Path", "Workspace Name", and "Title" for the workspace.

After setting the items, click the  button to save the project.

#### Setting example

- Save Folder Path : C:\Documents and Settings\  
Administrator\  
My Documents
- Workspace Name: Sample\_Workspace
- Title (option) : Sample Data

#### Point

##### ● Saving workspaces with compression/unpacking workspaces

Saving workspaces with compression makes the data passing easier. Also, unpacking workspaces saved with compression and opening them.

For details, refer to HELP of MELSOFT Navigator.

## 3.10.2 Overwriting workspaces

Save an open workspace with the same name.

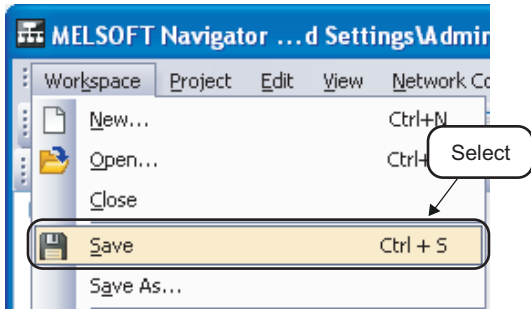

- Select [Workspace] ⇒ [Save] (  ) in the menu bar to overwrite and save the workspace.

1  
OVERVIEW2  
SCREEN  
CONFIGURATION3  
OPERATING PROCEDURE  
OF MELSOFT NAVIGATOR4  
USING SYSTEM  
LABELS5  
CREATING SYSTEM  
BACKUP DATA6  
USING PROGRAM  
JUMP FUNCTION

## 3.11 Printing Workspaces

This section explains a method for printing a created workspace.

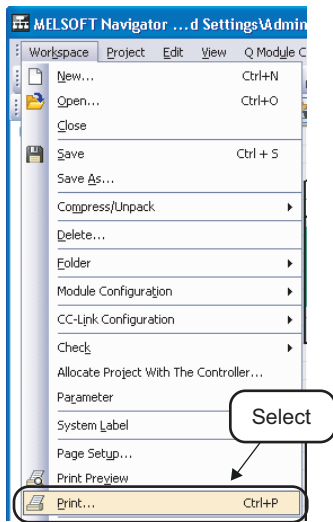

1. Select [Workspace] ⇒ [Print] in the menu bar to display the "Print" dialog box.

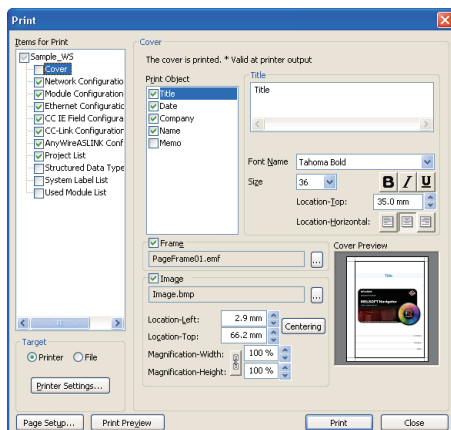

2. Select items for print and click the  button to display the "Print" dialog box.

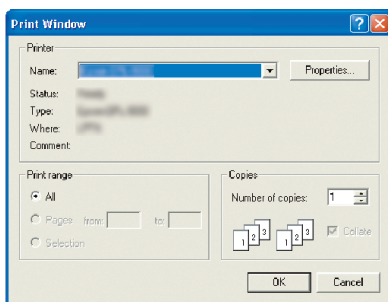

3. Select a printer and click the  button.

### Point

#### ● Print output target

By selecting "File" for "Target", data can be saved in a CSV format file or a text format file. For details, refer to the Help function of MELSOFT Navigator.



## 3.12 Closing Workspaces

This section explains a method for closing an open workspace.

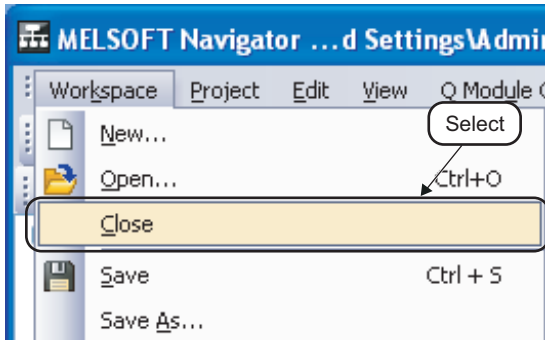

1. Select [Workspace] ⇒ [Close] in the menu bar.

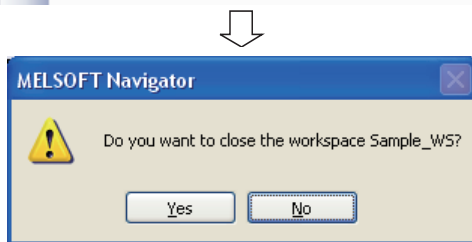

2. Click the  button to close the workspace.

### Point

When the workspace has not been saved, the following message is displayed.

Click the  button to save the workspace.

Click the  button to close the workspace without saving it.

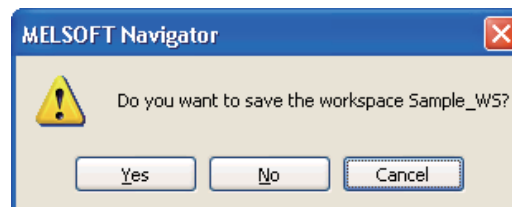

## 3.13 Exiting MELSOFT Navigator

This section explains a method for exiting MELSOFT Navigator.

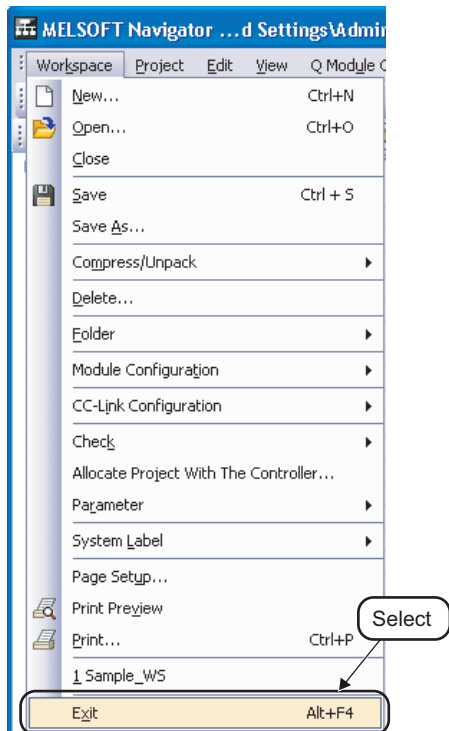

- Select [Workspace] ⇒ [Exit] in the menu bar to exit MELSOFT Navigator.

### Point

When the workspace is being opened, the following message is displayed.

Click the  button to close the workspace.

Click the  button to abort the operation of exiting MELSOFT Navigator.

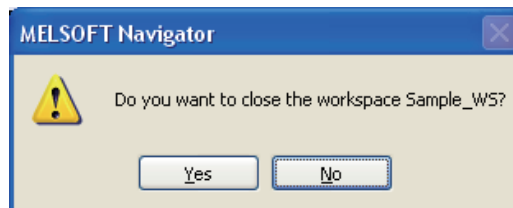



# 4 USING SYSTEM LABELS

This chapter explains the methods for using system labels which are shared within workspace of programmable controller projects, motion controller projects, and GOT projects.

4.1	Registering System Labels in MELSOFT Navigator. . . . .	4-2
4.2	Utilizing Existing Labels as System Labels . . . . .	4-11
4.3	Using System Labels on another personal computer . . . . .	4-17
4.4	Checking System Labels . . . . .	4-19

## 4.1 Registering System Labels in MELSOFT Navigator

This section explains a method for using system labels with the top-down design method under the following system configuration.

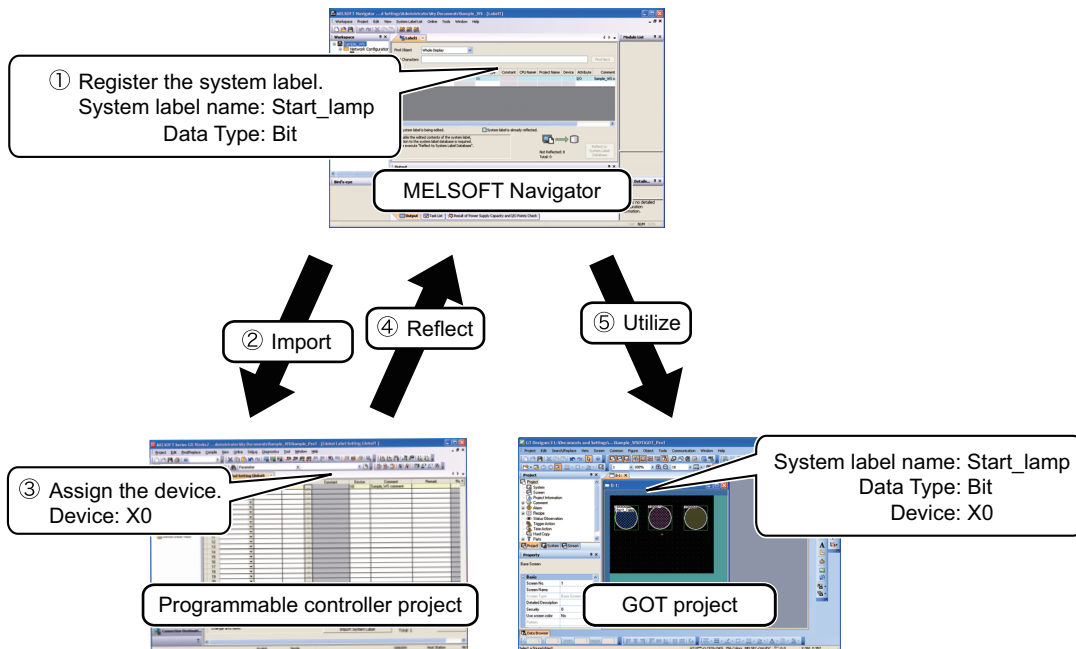
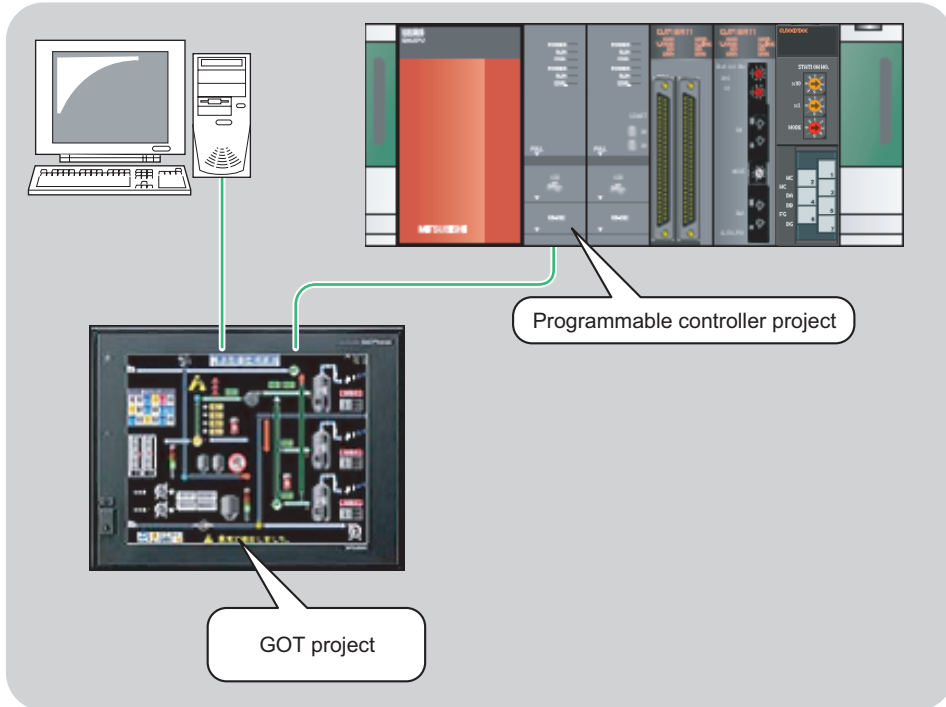

## 4.1.1 Registering system labels in MELSOFT Navigator

Create and register system labels in MELSOFT Navigator.

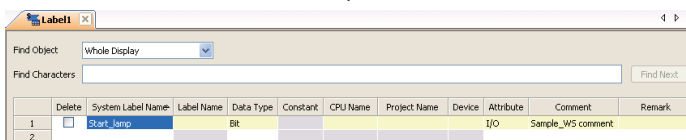
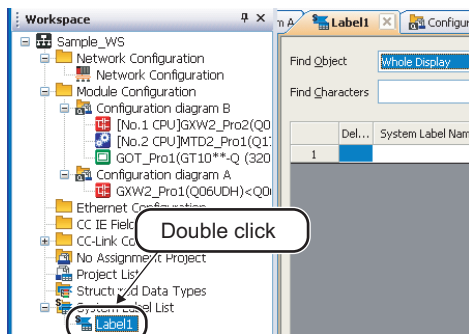
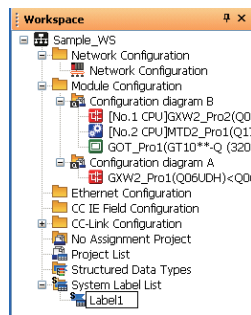
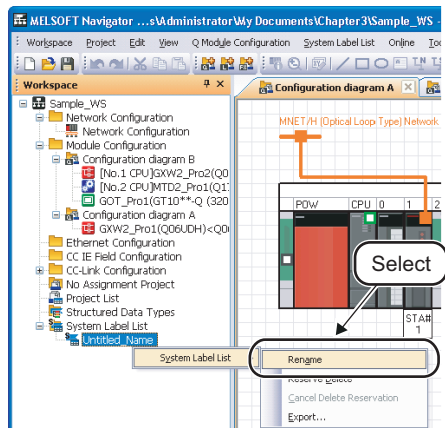

(To the next page)

1. Right-click "Undefined\_Name" under "System Label List" on the Workspace window, and select [System Label List] ⇒ [Rename] in the shortcut menu.

2. Enter "Label1" and change the system label name.

3. Double-click "Label1" on the Workspace window.  
The system label list window is displayed.

4. Set "System Label Name", "Data Type", "Attribute", and "Comment" for the system label to be registered.

### Setting example

- System Label Name: Start\_lamp
- Data Type : Bit
- Attribute (option) : I/O
- Comment (option) : Sample\_WS comment

1 OVERVIEW

2 SCREEN CONFIGURATION

3 OPERATING PROCEDURE OF MELSOFT NAVIGATOR

4 USING SYSTEM LABELS

5 CREATING SYSTEM BACKUP DATA

6 USING PROGRAM JUMP FUNCTION

(From the previous page)

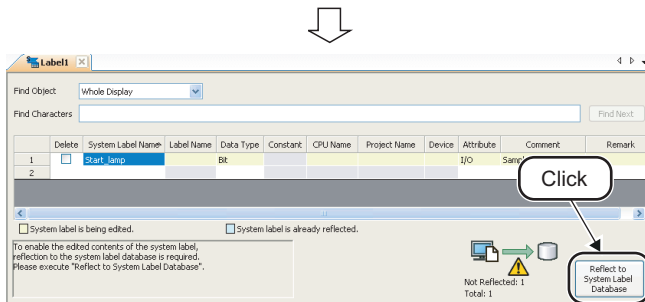
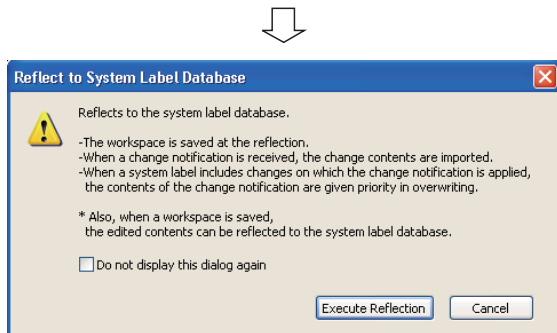
5. Click the  button.

6. The message shown on the left is displayed.

Read the message and click the  button. The system label is registered to the system label database, and the cell color turns light blue.

**Point****● Registering system labels**

System labels can also be registered by saving the workspace after setting the system labels to be registered.

**● Deleting system labels**

Delete system labels registered in MELSOFT Navigator by following the procedure below.

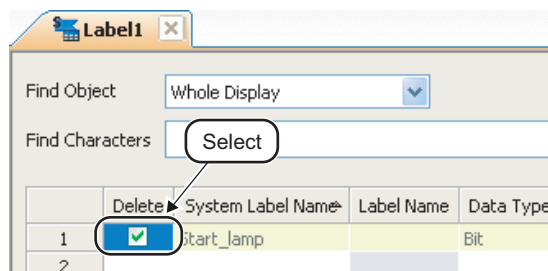

1. Select the system label to be deleted.

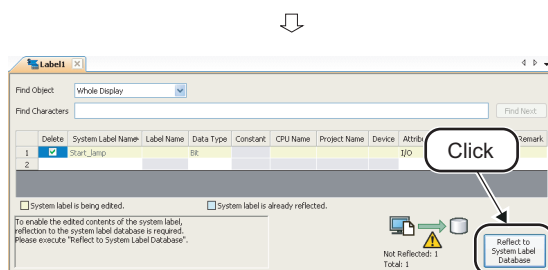
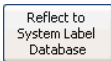
2. Click the  button to delete the selected system label.**● Importing/Exporting system labels**

System labels created in CSV format or text format can be imported to the workspace. Also, system labels created in the workspace can be exported in CSV format or text format.

For details, refer to Help of MELSOFT Navigator.

## 4.1.2 Assigning devices to system labels

Import system labels registered in MELSOFT Navigator to global labels of programmable controller project and assign devices to system labels to be used in other projects.  
For importing system labels to labels of motion controller project, follow the same procedure as described below.

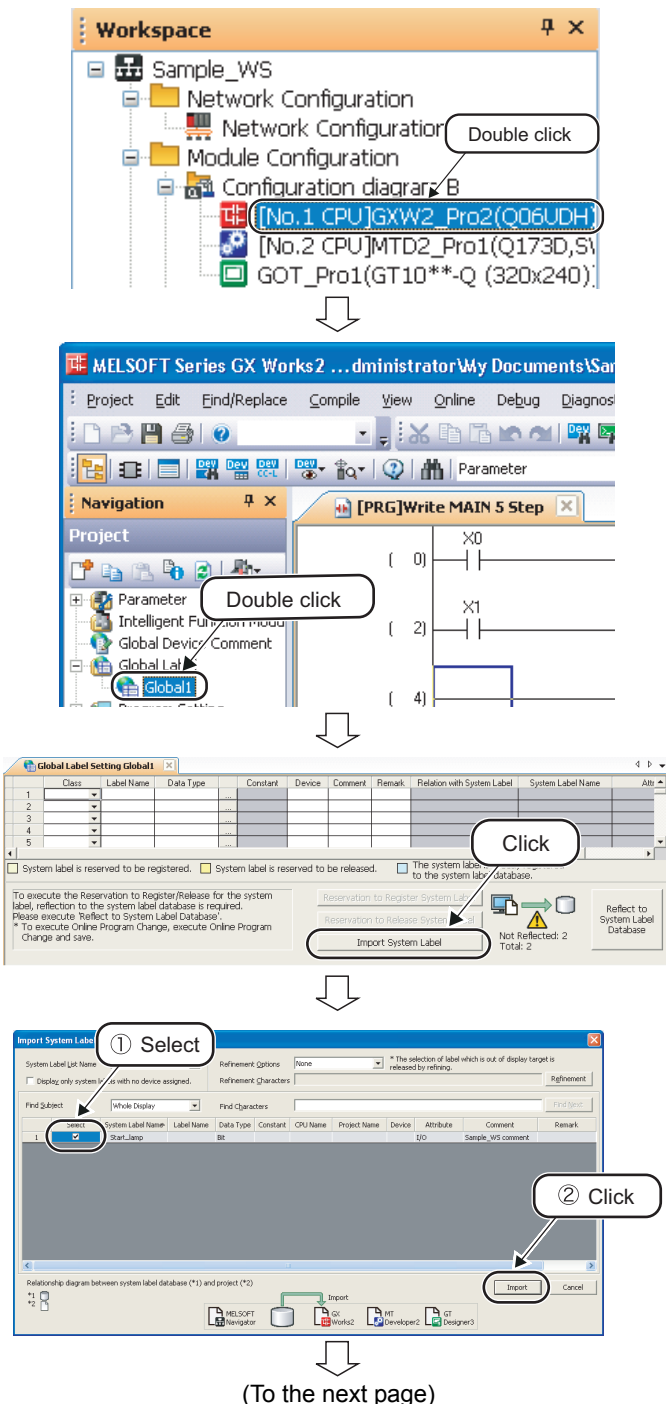

1. Double-click "GXW2\_Pro2" on the Workspace window to display the programmable controller project.
2. Double-click "Global1" on the Navigation window of GX Works2 to display the Global Label Setting window.
3. Click the **Import System Label** button on the Global Label Setting window to display the "Import System Labels to Project" dialog box.
4. Select a system label to be imported, and click the **Import** button.

1 OVERVIEW

2 SCREEN CONFIGURATION

3 OPERATING PROCEDURE OF MELSOFT NAVIGATOR

4 USING SYSTEM LABELS

5 CREATING SYSTEM BACKUP DATA

6 USING PROGRAM JUMP FUNCTION

(From the previous page)

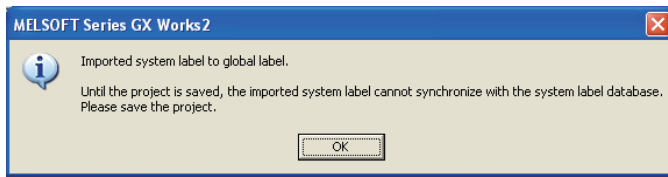

	Class	Label Name	Data Type	Constant	Device	Comment
1	VAR_GLOBAL	Start_lamp	Bit	...	X0	Sample_WS comment
2				...		
3				...		
4				...		
5				...		
6				...		

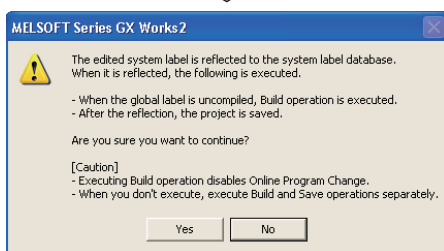
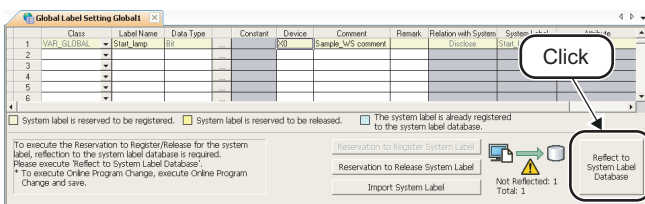

(To the next page)

5. The message shown on the left is displayed.

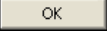
Read the message and click the  button to register system labels registered in MELSOFT Navigator as global labels of GX Works2.

6. Set a device to the imported system label.

Setting example

- Device : X0

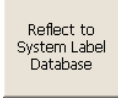
7. Click the  button.

8. The message shown on the left is displayed.

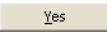
Read the message and click the  button to execute Build and Save the project.

For the compilation, refer to the following manuals.

 GX Works2 Version 1 Operating Manual (Common)

 GX Works2 Version 1 Operating Manual (Simple Project)

 GX Works2 Version 1 Operating Manual (Structured Project)

 GX Works2 Beginner's Manual (Simple Project)

 GX Works2 Beginner's Manual (Structured Project)



(From the previous page)

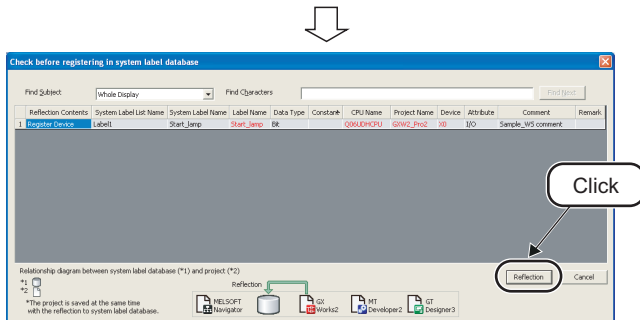

9. The "Check before registering in system label database" dialog box is displayed.  
 Contents to be registered are displayed in red.  
 Check the contents and click the **Register** button.

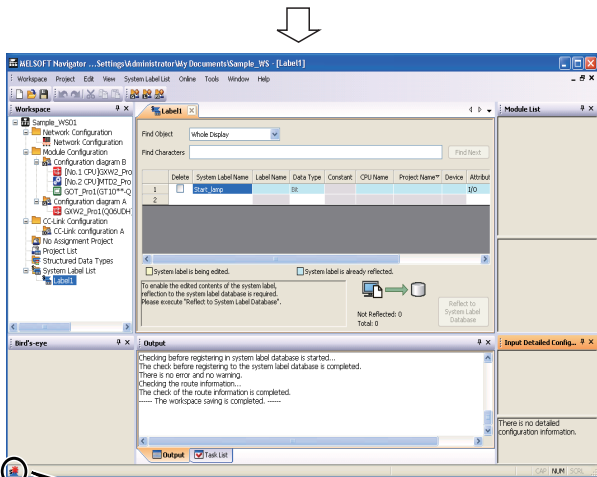

10. The system label notification icon is displayed on the status bar of MELSOFT Navigator.

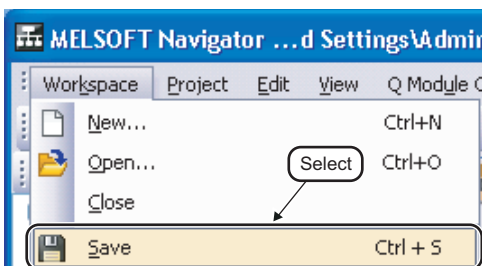
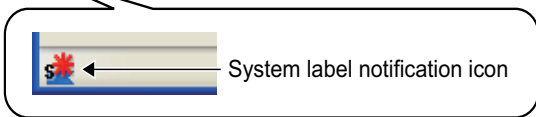

11. Select [Workspace] ⇒ [Save] in the menu bar of MELSOFT Navigator to save the workspace.  
 The system label list of MELSOFT Navigator is updated.

**Point**

- **Updating system labels**  
 After checking registration of system labels to the system label database in the step 9, system labels of MELSOFT Navigator can be updated by selecting [Workspace] ⇒ [System Label] ⇒ [Change Contents of System Label Database] in the menu bar of MELSOFT Navigator and save the project.
- **System labels of GX Works2.**
  - System labels imported to projects can be used as global labels.
  - System labels cannot be used when using a project without labels in GX Works2.  
 Change project type from 'without labels' to 'with labels'. For details of change project type, refer to the following manual.

👉 GX Works2 Version 1 Operating Manual (Common)

1	OVERVIEW
2	SCREEN CONFIGURATION
3	OPERATING PROCEDURE OF MELSOFT NAVIGATOR
4	USING SYSTEM LABELS
5	CREATING SYSTEM BACKUP DATA
6	USING PROGRAM JUMP FUNCTION

### 4.1.3 Using system labels in GT Designer3

Utilize system labels to which devices are assigned in a programmable controller project for a GOT project.

In GOT projects, system label names can be specified when setting devices to created objects.

For drawing objects in GOT projects, refer to the following manuals.

☞ • GT Designer3 Version 1 Screen Design Manual (Fundamentals)

☞ • GT Designer3 Version 1 Screen Design Manual (Functions)

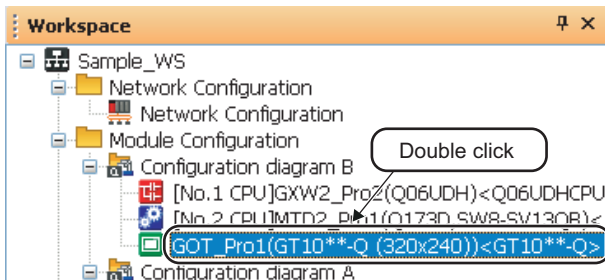

1. Double-click the project on the Workspace window to open the GOT project.

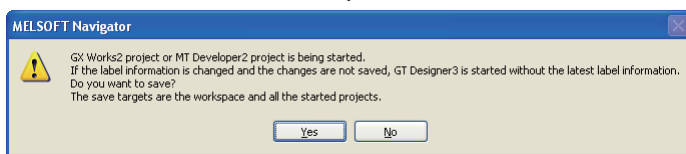

2. The message shown on the left is displayed when a GX Works2 or MT Developer2 project is being opened.

Read the message and click the  button.

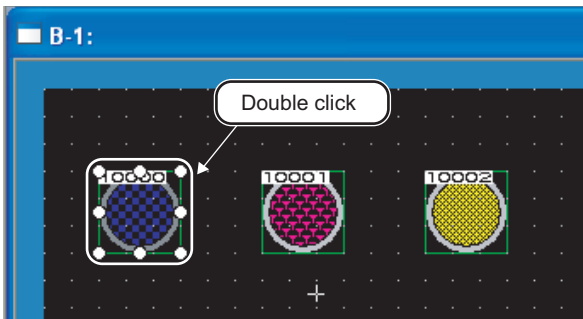

3. 4. Double-click the created object to display the dialog box of the object.

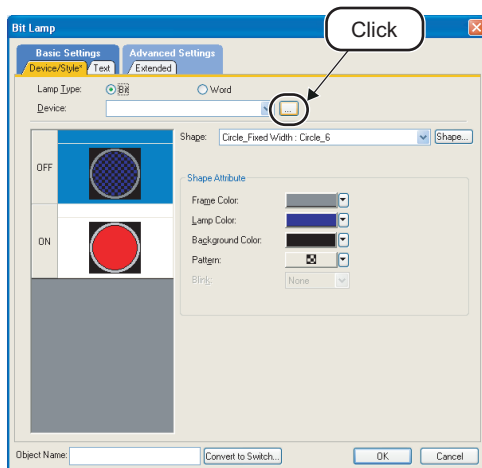



4. Click  to display the "Select CH No." dialog box.

(To the next page)

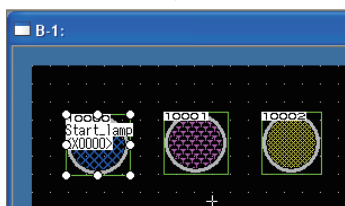
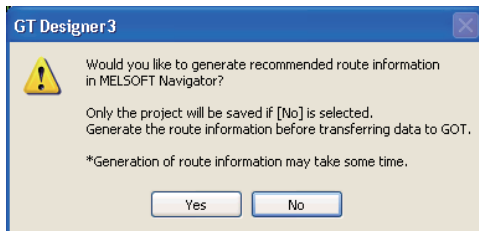
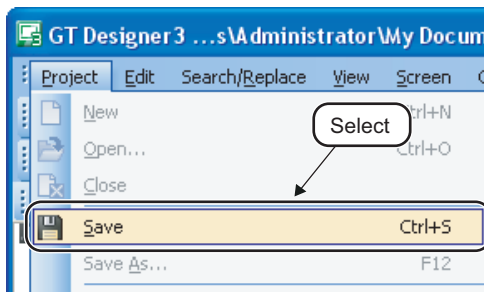
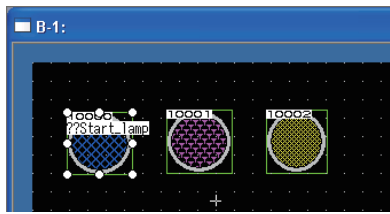
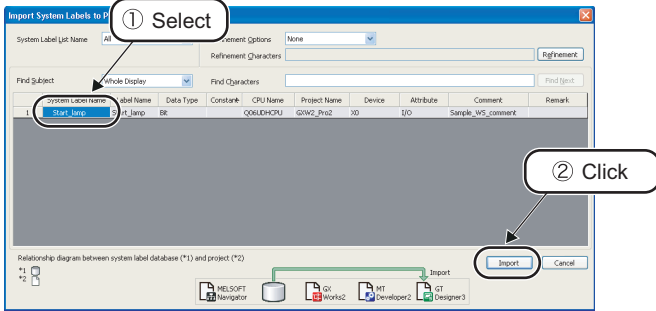
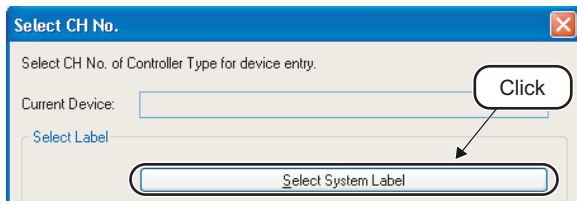
(From the previous page)

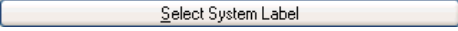

5. Click the  button to display the "Import System Labels to Project" dialog box.
6. Select a system label to be used and click the  button.
7. After the settings are completed, the system label name is displayed on the object.
8. Select [Project] ⇒ [Save] in the menu bar.
9. The message shown on the left is displayed. Read the message and click the  button.
10. The system label is ready to be referred.

1	OVERVIEW
2	SCREEN CONFIGURATION
3	OPERATING PROCEDURE OF MELSOFT NAVIGATOR
4	USING SYSTEM LABELS
5	CREATING SYSTEM BACKUP DATA
6	USING PROGRAM JUMP FUNCTION

**Point**

## ● Referencing system labels

- After saving GT Designer3 project by clicking  button on the message in the step 9, system labels can also be referred by selecting [Workspace] ⇒ [System Label] ⇒ [Route Information/Routing Parameters] in the menu bar of MELSOFT Navigator to create the route information/routing parameters.
- An error which occurs when referring to system labels can be confirmed on the “System Label Update/Check” screen in GT Designer3. For details, refer to the following manual.

 GT Designer3 Version1 Screen Design Manual (Fundamentals)

## 4.2 Utilizing Existing Labels as System Labels

This section explains a method for using system labels with the bottom-up design method under the following system configuration.

The following is an example of utilizing system labels registered in the programmable controller project for the motion controller project.

System labels can also be used between programmable controller projects or between motion controller projects.

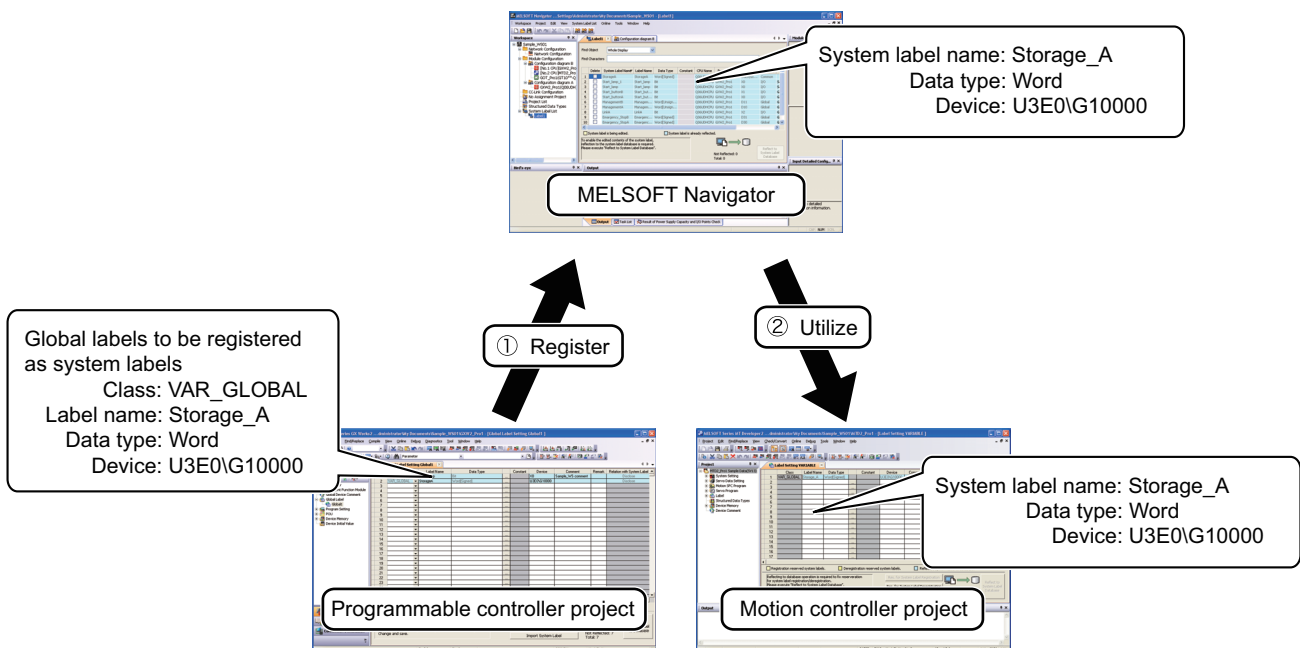
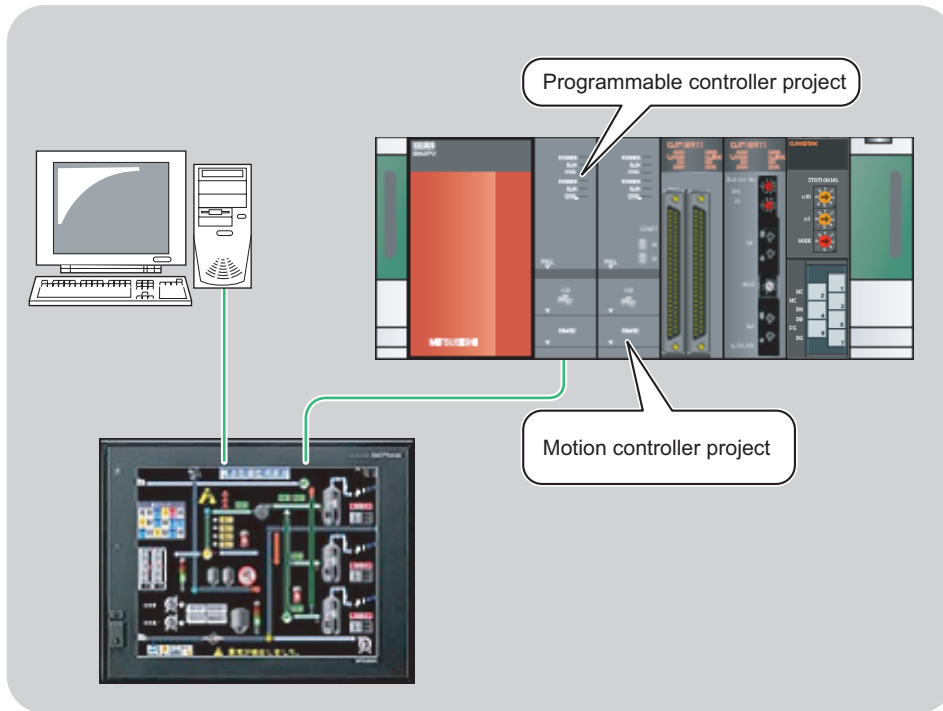

1	OVERVIEW
2	SCREEN CONFIGURATION
3	OPERATING PROCEDURE OF MELSOFT NAVIGATOR
4	USING SYSTEM LABELS
5	CREATING SYSTEM BACKUP DATA
6	USING PROGRAM JUMP FUNCTION

### 4.2.1 Registering labels as system labels

Register global labels already set in the programmable controller project as system labels, and reflect them to MELSOFT Navigator.

The following is an example of registering global labels of programmable controller project as system labels.

For registering labels of motion controller project, follow the same procedure as described below.

1. Double-click the project on the Workspace window to open the programmable controller project.

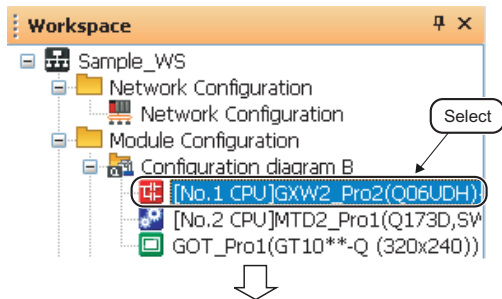

2. Double-click the global label name on the Navigation window of GX Works2 to display the Global Label Setting window.

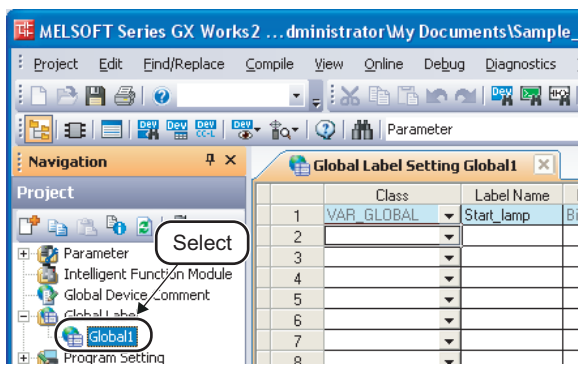

3. Select a global label to be registered as a system label, and click the **Reservation to Register System Label** button.

The cell color of the selected global label turns yellow.

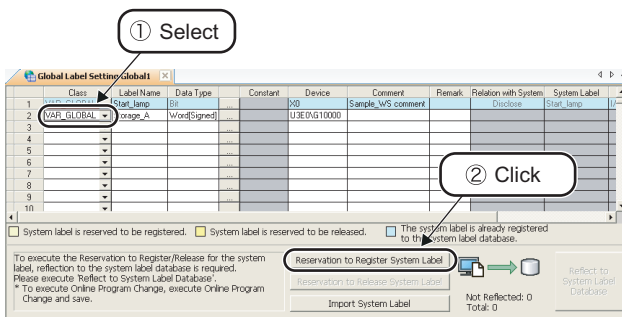

4. Click the **Reflect to System Label Database** button.

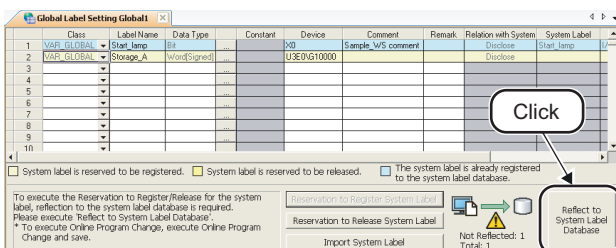

(To the next page)

(From the previous page)

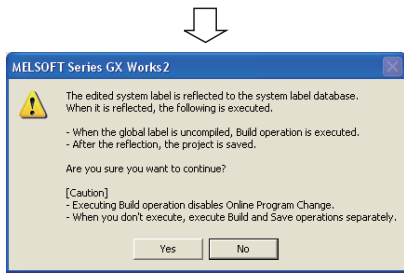

- The message shown on the left is displayed.

Read the message and click the  button to execute Build and Save the project.

For the compilation, refer to the following manuals.

- GX Works2 Version 1 Operating Manual (Common)
- GX Works2 Version 1 Operating Manual (Simple Project)
- GX Works2 Version 1 Operating Manual (Structured Project)
- GX Works2 Beginner's Manual (Simple Project)
- GX Works2 Beginner's Manual (Structured Project)

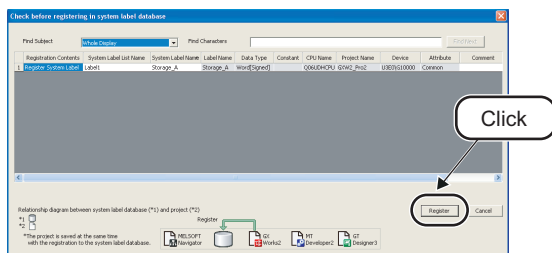

- The "Check before registering in system label database" dialog box is displayed.

Click the  button to register the system label, and the cell color turns light blue.

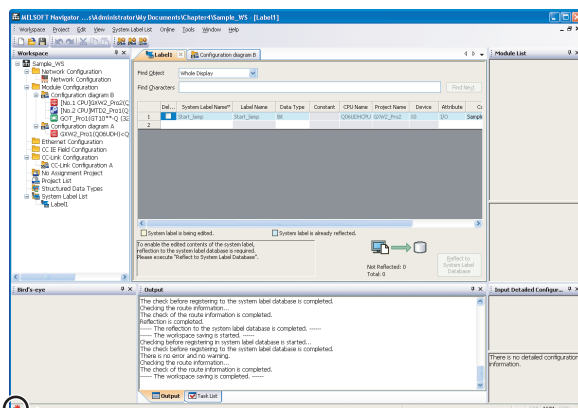

- The system label notification icon is displayed on the status bar of MELSOFT Navigator.

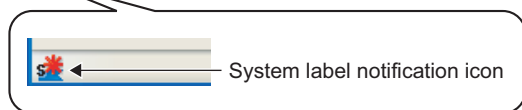

(To the next page)

1	OVERVIEW
2	SCREEN CONFIGURATION
3	OPERATING PROCEDURE OF MELSOFT NAVIGATOR
4	USING SYSTEM LABELS
5	CREATING SYSTEM BACKUP DATA
6	USING PROGRAM JUMP FUNCTION

(From the previous page)

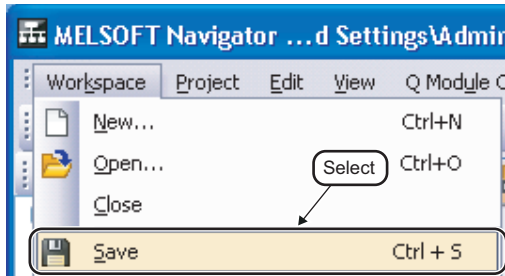

8. Select [Workspace] ⇒ [Save] in the menu bar of MELSOFT Navigator.

The system label created in the programmable controller project is reflected to MELSOFT Navigator.

### Point

- Changed contents of system labels  
When confirming the changed contents of system labels, select [Workspace] ⇒ [System Label] ⇒ [Change Notification History Display] in the menu bar of MELSOFT Navigator to display "Change Notification History" dialog box.



## 4.2.2 Using system labels in motion controller projects

Utilize system labels registered in the programmable controller project for a motion controller project.

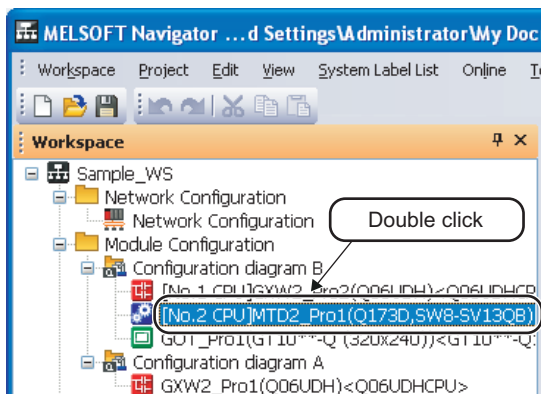

1. Double-click the project on the Workspace window to open the motion controller project.

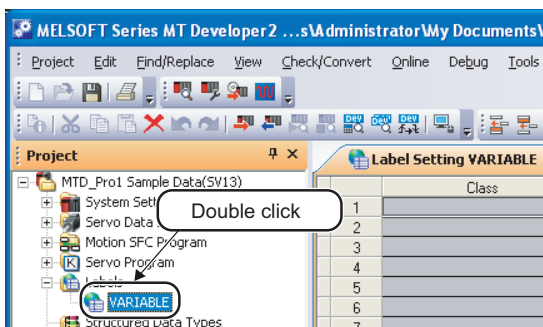

2. Double-click "VARIABLE" on the Navigation window of MT Developer2 to display the Label Setting window.

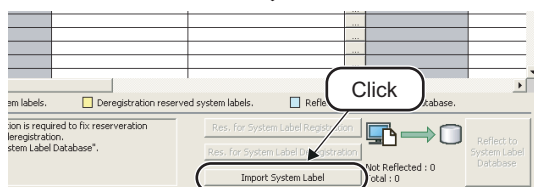

3. Click the **Import System Label** button on the Label Setting window to display the "Import System Labels to Project" dialog box.

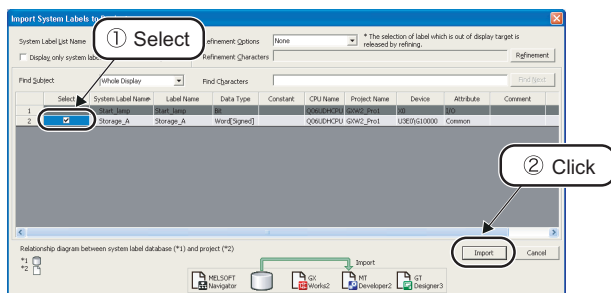

4. Select a system label to be imported, and click the **Import** button.

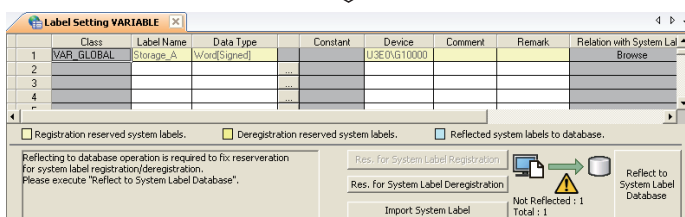

5. The system label is registered to the label setting editor.

(To the next page)

1 OVERVIEW

2 SCREEN CONFIGURATION

3 OPERATING PROCEDURE OF MELSOFT NAVIGATOR

4 USING SYSTEM LABELS

5 CREATING SYSTEM BACKUP DATA

6 USING PROGRAM JUMP FUNCTION

(From the previous page)

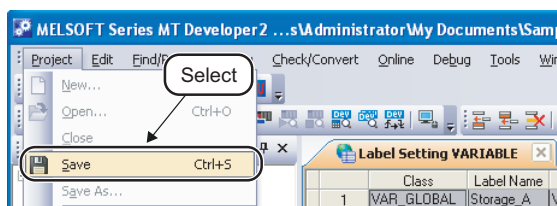
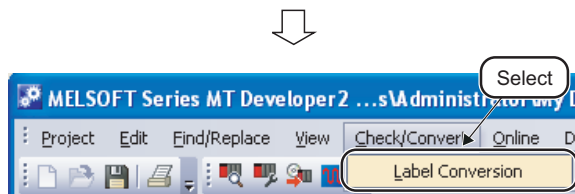

6. Select [Check/Convert] ⇒ [Label Conversion] in the menu bar of MT Developer2

7. The message shown on the left is displayed.

Read the message and click the  button.

8. Select [Project] ⇒ [Save] in the menu bar to save the project.

### Point

- Referencing system labels  
When referring to system labels, assign the device with attribute which can be referred from a programmable controller project or a motion controller project.  
For details, refer to the HELP function of MELSOFT Navigator.

## 4.3 Using System Labels on another personal computer

This section explains a method for utilizing created system labels on another personal computer.

For using system labels on another personal computer, create a workspace in MELSOFT Navigator, copy it to media such as USB memories, and edit the project.

The project edited on another personal computer requires verification and synchronization after the project is imported back to the original workspace. For details of import function, refer to Section 3.8.2.

The following is an example of processing verification and synchronization on system labels of programmable controller project. For processing verification and synchronization on motion controller projects, follow the same procedure as described below.

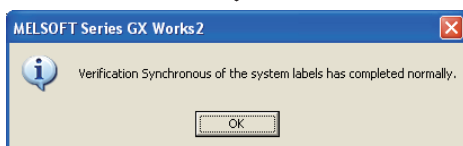
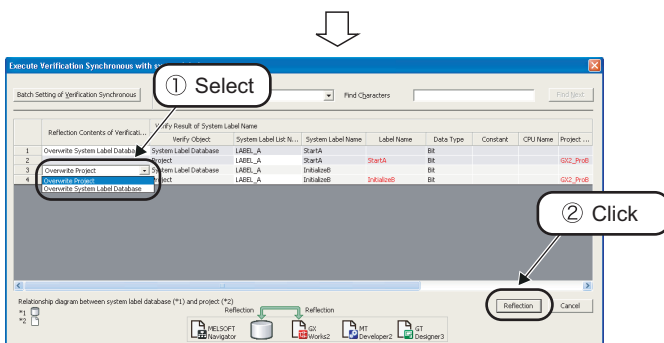
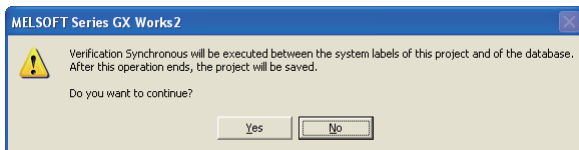
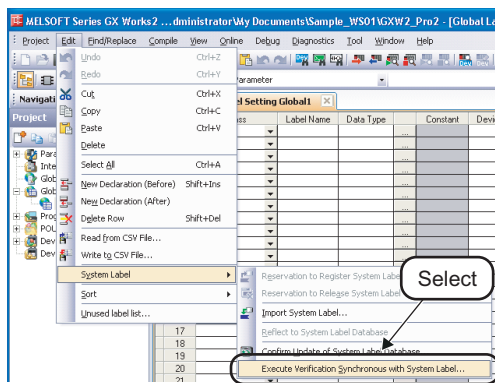

(To the next page)

1. Select [Edit] ⇒ [System Label] ⇒ [Execute Verification Synchronous with System Label] in the menu bar of GX Works2.

2. The message shown on the left is displayed.

Click the  button to display the "Execute Verification Synchronous with system label" dialog box.

3. Select an item under Reflection Contents of Verification Synchronous, and click the  button.

4. The message shown on the left is displayed.

Read the message and click the  button.

(From the previous page)

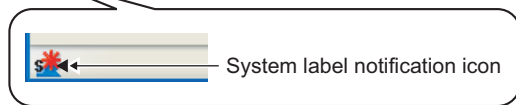
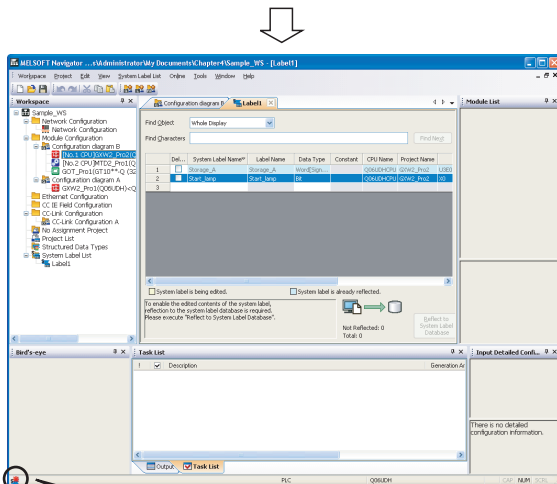

5. The system label notification icon is displayed on the status bar of MELSOFT Navigator.

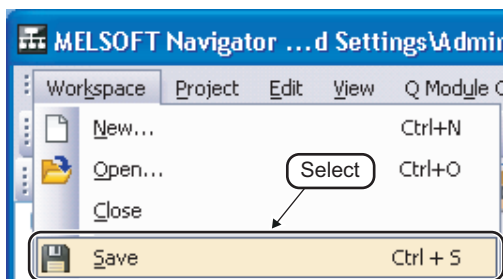

6. Select [Workspace] ⇒ [Save] in the menu bar of MELSOFT Navigator.

The system label database of MELSOFT Navigator is updated.

## 4.4 Checking System Labels

This section explains a method for batch checking conditions such as; module configurations of created system configuration, project allocation status, and system label consistency.

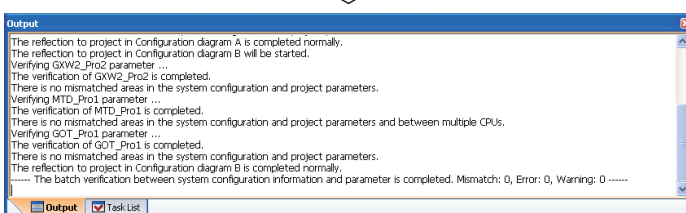
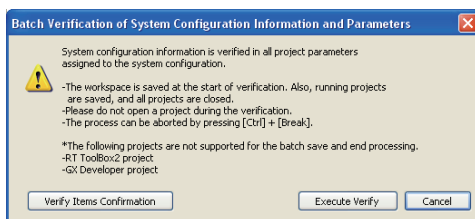
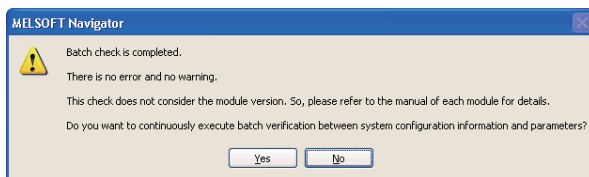
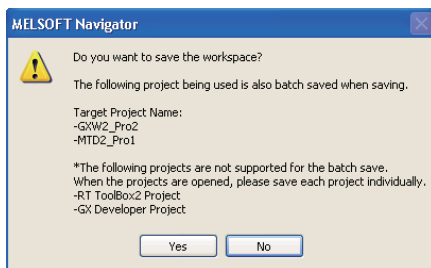
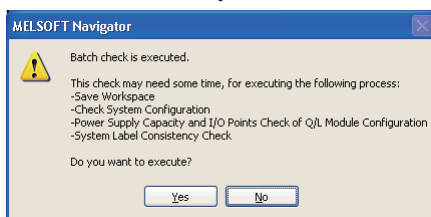
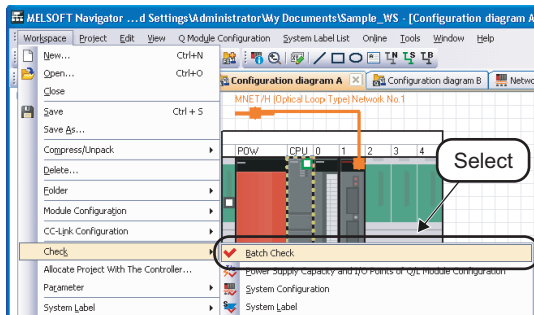

1. Select [Workspace] ⇒ [Check] ⇒ [Batch Check] in the menu bar.

2. The message shown on the left is displayed.

Read the message and click the  button.

3. The message shown on the left is displayed when a project is being opened in the workspace.

Read the message and click the  button.

4. The batch check is completed, and the message shown on the left is displayed.

For performing the batch verification of parameters, click the  button.

5. The message shown on the left is displayed.

Read the message and click the  button.

6. Execute the verification.

Error or Warning is displayed when the verification result contains an error. Check the error description on the Task List window and correct the error.

## Point

● **Checking only system label consistency**

Check the consistency of system labels registered to projects and labels of projects in which labels are defined.

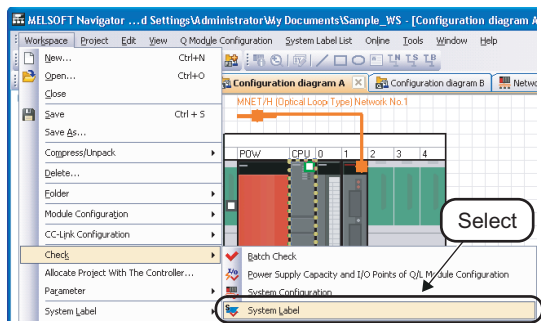

1. Select [Workspace] ⇒ [Check] ⇒ [System Label] in the menu bar.

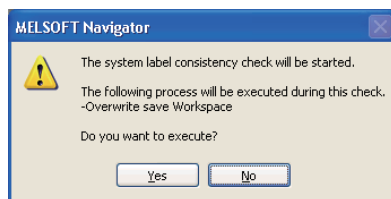

2. The message shown on the left is displayed.

Read the message and click the  button.

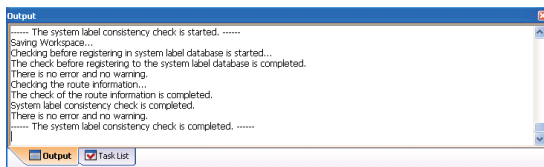

3. Execute the system label consistency check.

Error or Warning is displayed when the check result contains an error. Check the error description on the Task List window and correct the error.



# 5 CREATING SYSTEM BACKUP DATA

This chapter explains the methods for saving programmable controller project, motion controller project, and GOT project which are batch read from controllers.

5.1	Setting Batch Read Password . . . . .	5-2
5.2	Executing Batch Read Function . . . . .	5-4

1	OVERVIEW
2	SCREEN CONFIGURATION
3	OPERATING PROCEDURE OF MELSOFT NAVIGATOR
4	USING SYSTEM LABELS
5	CREATING SYSTEM BACKUP DATA
6	USING PROGRAM JUMP FUNCTION

## 5.1 Setting Batch Read Password

This section explains a method for setting a batch read password. This function limits users who can execute the batch read function.

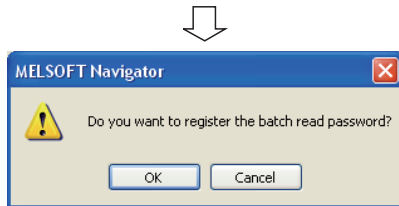
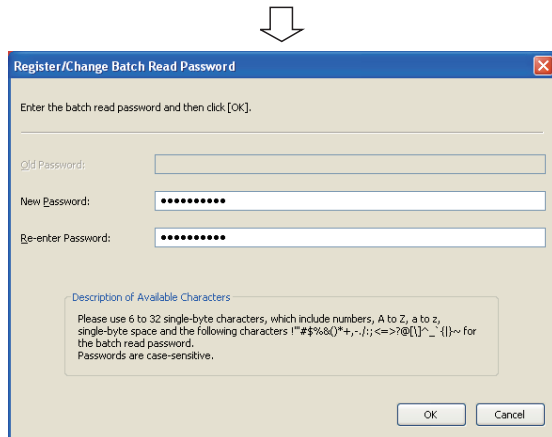
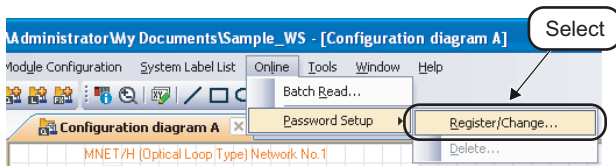

1. Select [Online] ⇒ [Password Setup] ⇒ [Register/Change] in the menu bar to display the "Register/Change Batch Read Password" dialog box.

2. Enter the password for "New Password" and "Re-enter Password", and click the  button.

### Setting example

- New Password : MITSUBISHI09
- Re-enter Password: MITSUBISHI09

3. The message shown on the left is displayed.

Read the message and click the  button.

The batch read password is registered.



**1**  
OVERVIEW

**2**  
SCREEN CONFIGURATION

**3**  
OPERATING PROCEDURE OF MELSOFT NAVIGATOR

**4**  
USING SYSTEM LABELS

**5**  
CREATING SYSTEM BACKUP DATA

**6**  
USING PROGRAM JUMP FUNCTION

  

**● Changing batch read password**  
Change the batch read password on the "Register/Change Batch Read Password" dialog box.

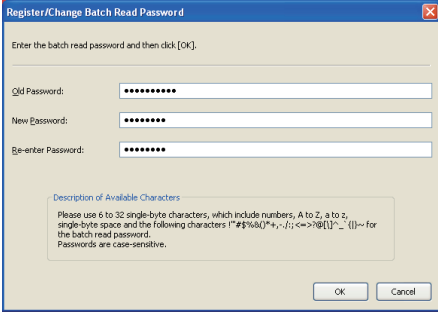

**● Deleting batch read password**  
Delete the batch read password by following the procedure below.

**1.**

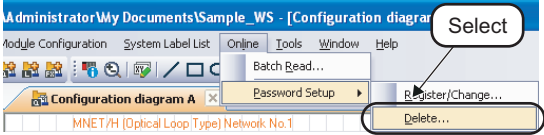

↓

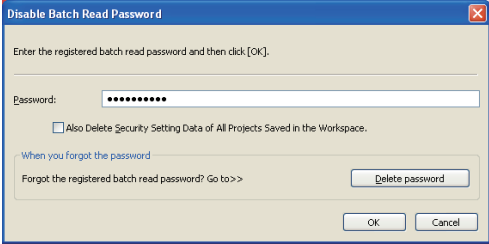

↓

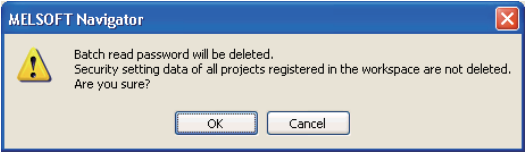

**2.**

**3.** The message shown on the left is displayed.

Read the message and click the  button.

The batch read password is deleted.

**3.**

Enter the batch read password and then click [OK].

Old Password: [password field]

New Password: [password field]

Re-enter Password: [password field]

Description of Available Characters

Please use 6 to 32 single-byte characters, which include numbers, A to Z, a to z, single-byte space and the following characters: !"#%&'()\*+,-./:;<=>?@["]`{|}~ for the batch read password. Passwords are case-sensitive.

[OK] [Cancel]

**1.** Select [Online] ⇒ [Password Setup] ⇒ [Delete] in the menu bar to display the "Delete Batch Read Password" dialog box.

**2.** Enter the registered batch read password, and click the  button.

## 5.2 Executing Batch Read Function

This section explains a method for batch-reading projects from controllers and save them as backup data.

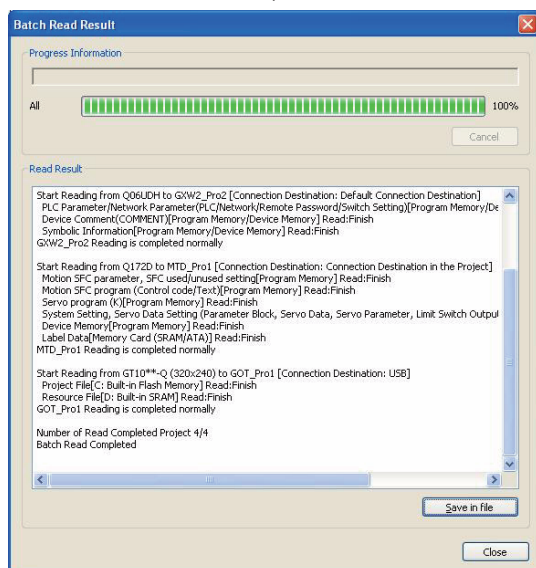
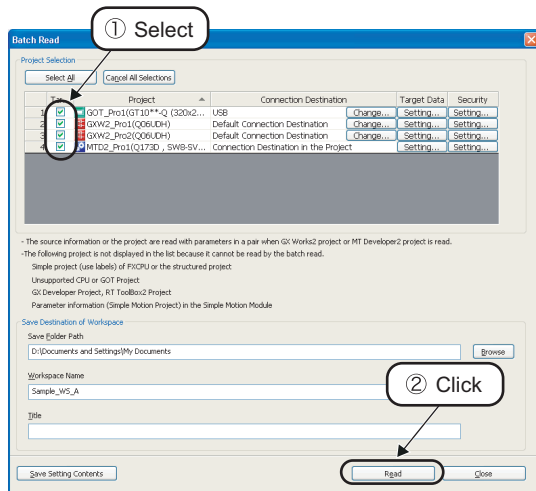
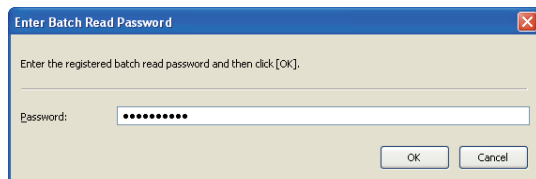
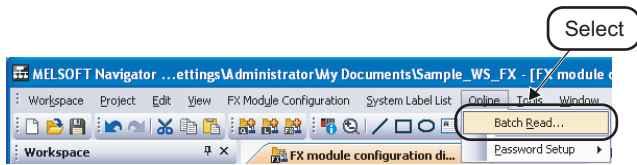

1. Select [Online] ⇒ [Batch Read] in the menu bar to display the "Enter Batch Read Password" dialog box.
2. Enter the registered batch read password, and click the  button to display the "Batch Read" dialog box.

### Setting example

- Password: MITSUBISHI09

3. Select the projects to be read, and click the  button.

### Setting example

- Selected Project : GOT\_Pro1  
GXW2\_Pro1  
GXW2\_Pro2  
MTD2\_Pro1
- Workspace Name: Sample\_WS\_A

4. The batch read function is completed, and the "Batch Read Result" dialog box is displayed.

The result is displayed under "Read Result".



### ● Changing connection destination

Change the connection destination by following the procedure below.

The following is an example of specifying programmable controller project data.

For specifying motion controller project data or GOT project data, follow the same procedure as described below.

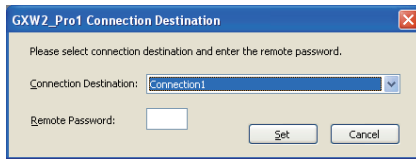
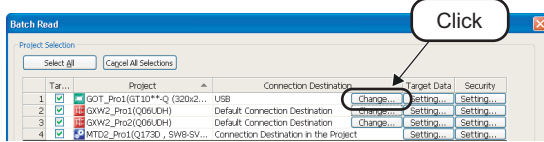

1. Click the **Change...** button under "Connection Destination" on the "Batch Read" dialog box to display the Connection Destination dialog box.

2. Select a connection destination, and click the **Set** button.

If a remote password is set for the selected connection destination, enter 4-digit remote password.

For details on remote password, refer to the following manual.

☞ • GX Works2 Version 1 Operating Manual (Common)

**Point!**

● **Specifying data to be read**

Specify data to be read from controllers by following the procedure below.

The following is an example of specifying programmable controller project data.

For specifying motion controller project data and GOT project data, follow the same procedure as described below.

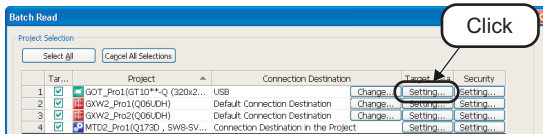

1. Click the **Setting...** button under "Target Data" on the "Batch Read" dialog box to display the Target Data Setting dialog box.



<Q series/L series>

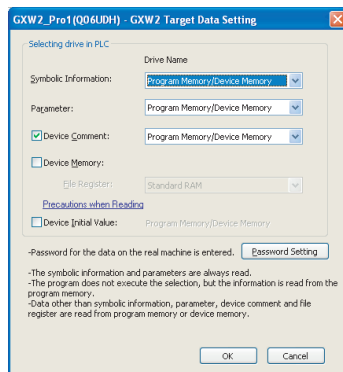

2. Specify data to be read, and click the **OK** button.

For details, refer to the Help function of MELSOFT Navigator.

<FX series>

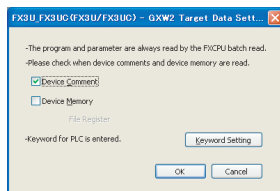

● **Security set for project**

When the security is set for projects of controllers, reset the security before executing the batch read function.

Reset the security by following the procedure below.

The following is an example of resetting the security of programmable controller project.

For resetting the security of motion controller project and GOT project, follow the same procedure as described below.

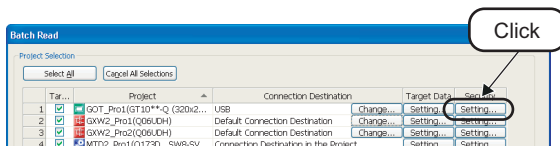

1. Click the **Setting...** button under "Security" on the "Batch Read" dialog box to display the Security dialog box.

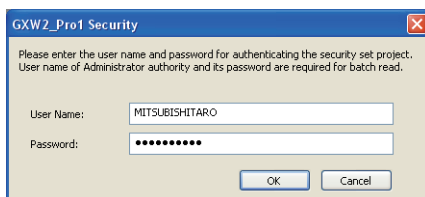

2. Enter a user name and a password, and click the **OK** button.

For details, refer to the Help function of MELSOFT Navigator.



# 6 USING PROGRAM JUMP FUNCTION

This chapter explains the program jump function which can start the motion SFC programs/servo programs that are linked with the motion controller programs, using the SFCS instructions/SVST instructions of the ladder programs in the multiple CPU system.

6.1	Example of System Configuration . . . . .	6-2
6.2	Program Jump Function . . . . .	6-3

1	OVERVIEW
2	SCREEN CONFIGURATION
3	OPERATING PROCEDURE OF MELSOFT NAVIGATOR
4	USING SYSTEM LABELS
5	CREATING SYSTEM BACKUP DATA
6	USING PROGRAM JUMP FUNCTION

## 6.1 Example of System Configuration

This section explains a method for using the program jump function under the following system configuration.

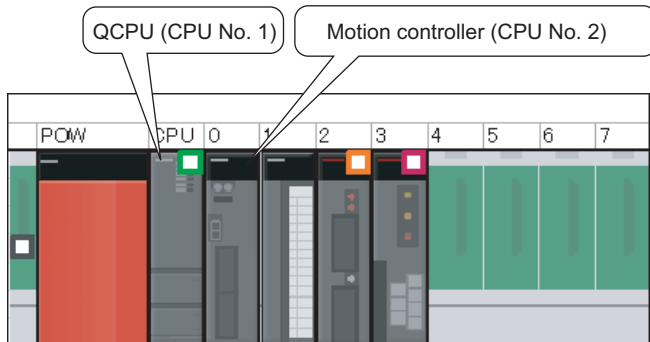

### ■ Motion controller start-up programs

The following are the instructions which start motion controller programs used in ladder programs.

- SFCS instruction (Motion SFC program start-up)
- SVST instruction (Servo program start-up)

For details, refer to the following manuals.

☞ Motion controller programming manual of Q173D/Q172D, Q173H/Q172H, and Q173/Q172.

This section explains the program jump function using the following ladder program.

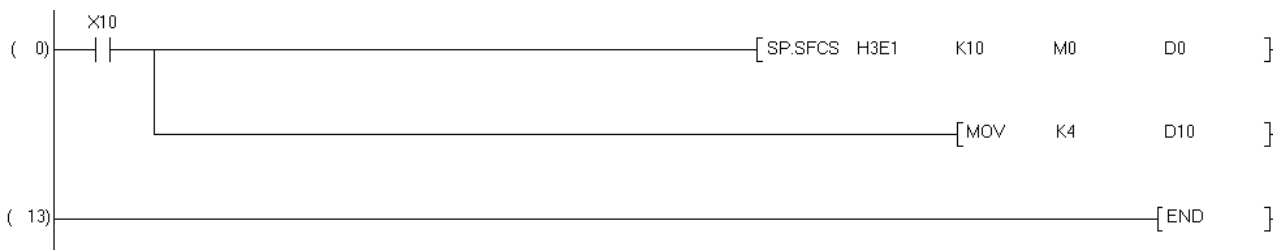

## 6.2 Program Jump Function

The following explains a method for using the program jump function in the SFCS instruction. For using the program jump function in the SVST instruction, follow the same procedure as described below.

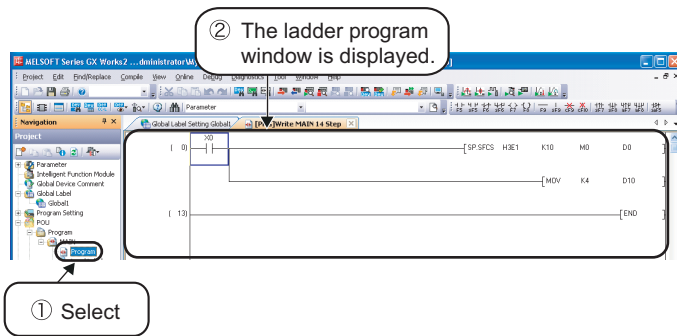
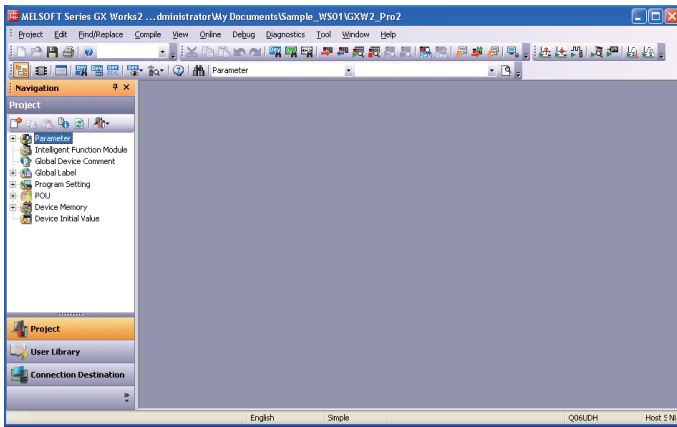
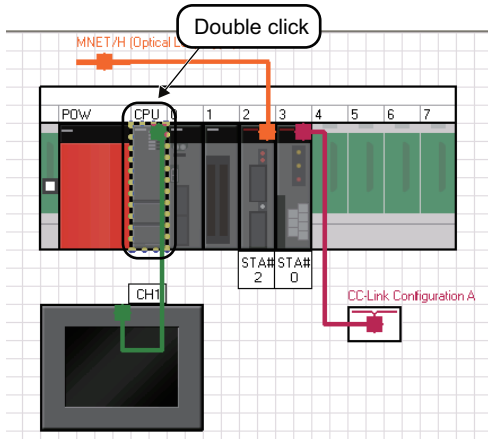

(To the next page)

1. On the Module Configuration window, double-click the controller to which a programmable controller project is allocated.
2. The programmable controller project is activated.
3. Select "POU" ⇒ "Program" ⇒ "MAIN" ⇒ "Program" on the Project window to display the ladder program window.

1	OVERVIEW
2	SCREEN CONFIGURATION
3	OPERATING PROCEDURE OF MELSOFT NAVIGATOR
4	USING SYSTEM LABELS
5	CREATING SYSTEM BACKUP DATA
6	USING PROGRAM JUMP FUNCTION

(From the previous page)

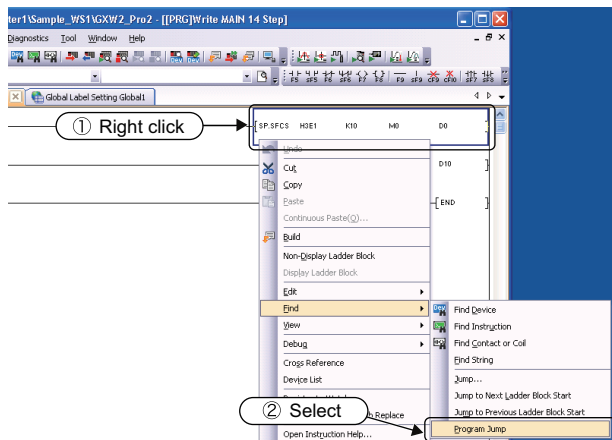

4. Right-click the SFCS instruction on the ladder program window and select [Find] ⇒ [Program Jump] in the shortcut menu.

5. The motion controller project, which is allocated to CPU No. 2 on the Module Configuration window, is activated and the target motion SFC program is displayed.

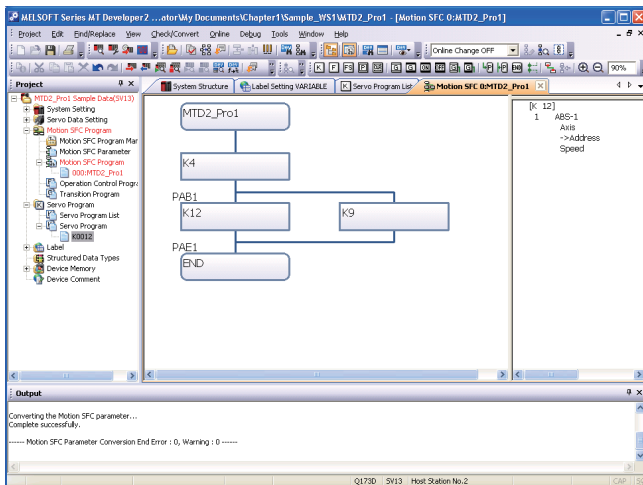





Microsoft, Windows are registered trademarks of Microsoft Corporation in the United States and other countries.

Ethernet is a trademark of Xerox Corporation.

All other company names and product names used in this manual are trademarks or registered trademarks of their respective companies.





# Beginner's Manual

MODEL	IQWK-HOW-O-E
MODEL CODE	13JZ44
SH(NA)-080902ENG-I(1312)KWIX	



HEAD OFFICE : TOKYO BUILDING, 2-7-3 MARUNOUCHI, CHIYODA-KU, TOKYO 100-8310, JAPAN  
NAGOYA WORKS : 1-14, YADA-MINAMI 5-CHOME, HIGASHI-KU, NAGOYA, JAPAN

When exported from Japan, this manual does not require application to the Ministry of Economy, Trade and Industry for service transaction permission.

Specifications subject to change without notice.