



MITSUBISHI CNC  
EZMotion-NC E60/E68 Series



Nagoya works has acquired the certification for Environmental management system ISO 14001 and Quality assurance management system ISO 9001



**⚠ Safety Warning**

To ensure proper use of the products listed in this catalog, please be sure to read the instruction manual prior to use.

**MITSUBISHI ELECTRIC CORPORATION**  
HEAD OFFICE: TOKYO BLDG., 2-7-3, MARUNOUCHI, CHIYODA-KU, TOKYO 100-8310, JAPAN

# EZMotion-NC E60/E68 Series

# EZMotion-NC E60/E68 SERIES

Simple, Fast, Reliable.

## New model of high cost-effectiveness

New concept CNC system, created for the genuine realization of numerical control of ordinary machine tool.

### Easy use and Excellent Performance

Mitsubishi CNC E60/E68: your trustworthy new standard for numerical control system. The new EZMotion-NC E60/E68 developed by Mitsubishi based on the latest technology has an inbuilt powerful 64-bit CPU, which can work with the new generation servo system to realize excellent speed and accuracy. Based on the world leading hardware level, first class performance and high speed is realized. The high efficiency is guaranteed to shorten processing time.

A wide range of functions: such as the customized screen, servo auto-tuning, synchronous tapping, Word editing, graphic tracing, PLC interface diagnosis and so on. The CASSETTE MEMORY can be used for the quick backup of all CNC data, which simplifies maintenance procedure. As all these functions improve the operability and observability, it is really your trustworthy and wise choice.

Energy  
Efficient  
Environment  
Economical  
Easy  
Excellent



## Excellent

- High performance CNC with 64-bit CPU
- Combining the new generation of servo-system MDS-R series
- Customized initial screen
- Compact servo motor and high resolution detector (131,072 pulses/rev.)
- Chinese (Simplified and Traditional), English,

## Easy

- Using the auto-tuning to derive optimum machine characteristics
- Using the MELSEC PLC development tool (GX Developer to better the development process)
- Only a parameter setting is necessary to convert the functions between lathe and miller
- CASSETTE MEMORY hardware can be used for the quick backup of all CNC DATA, which simplifies the maintenance procedure

## Economical

- The structure consists of the panel integrated CNC installation and the new generation of 2-axis servo drive unit (MDS-R series), greatly saving the space of the appliance cabinet of the machine
- Adopting analog output, making it possible to install an inverter as spindle

### EZMotion-NC E68

- Max. number of control axes: **8** (NC+Spindles+PLC+Auxiliary)
- Max. number of NC axes: **4**
- Max. number of spindles: **2**
- Max. number of PLC axes: **2**
- Operation/display panel: **8.4-inch COLOR TFT**
- Minimum control unit: **0.1 μm**

### EZMotion-NC E60

- Max. number of control axes: **5** (NC+Spindles+PLC+Auxiliary)
- Max. number of NC axes: **3**
- Max. number of spindles: **1** (Standard: Analog, S-package: Serial)
- Max. number of PLC axes: **1**
- Operation/display panel: **7.2-inch MONOCHROME LCD**
- Minimum control unit: **1 μm**

## Application

- Realize the numerical control of ordinary machine tool. • Most suitable for simple numerically controlled lathe and miller.

# Features

## High performance CNC with 64-bit CPU

- Using the latest assembly techniques to form two printed circuit boards, which consists of the NC main board and the memory board, to realize reliable functionality and display.
- Higher reliability because of few components.

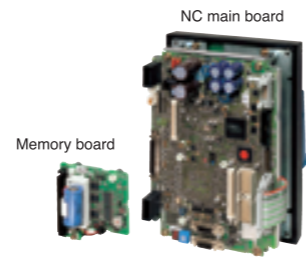

## Customized initial screen

The power-on starting screen can be customized to meet the requirements of various customers. The picture can be created with drawing software, saved in bitmap format, and finally transmitted to CNC.

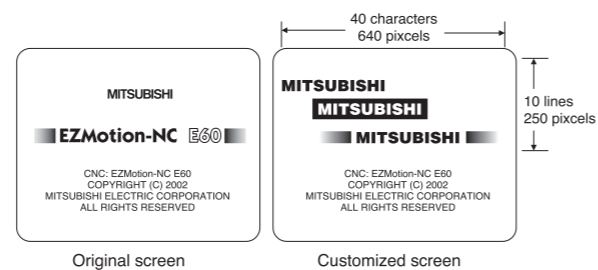

## IC Card Interface (supported by E68)

IC card interface is available on the front of the communication terminal. NC program and other NC internal data can be saved in commercial memory cards.



## All CNC DATA is stored in the CASSETTE MEMORY hardware, which simplifies maintenance procedure

Use CASSETTE MEMORY (HR450) to BACK UP the CNC DATA (used for setup by a machine tool builder)

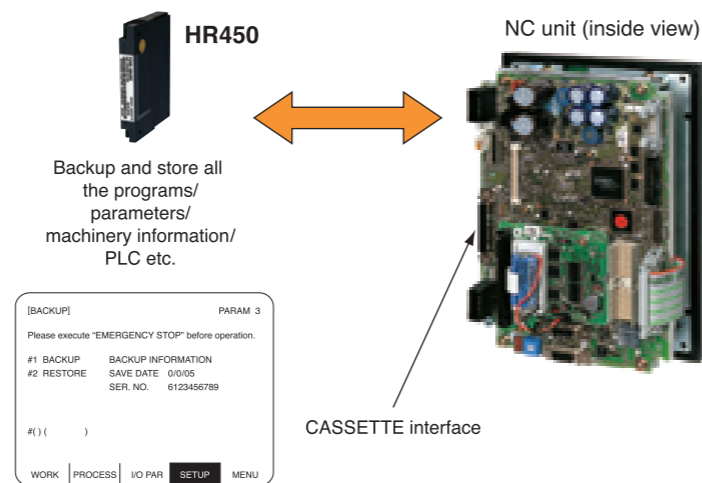

## High-speed High-accuracy Machining can be Achieved in a Highly Efficient Style

### Smooth High-Gain (SHG) control

The fast-response and stable position loop control system allows very high-gain performance. Smooth acceleration is available without adding any filter to post-interpolation commands (no path deviation due to command filter).

- A high-gain system has been established by developing a stable position loop control system that offers excellent response characteristics.
- Smooth acceleration has been realized without the application of S-type or other filters after interpolation command (no locus errors due to command filter).

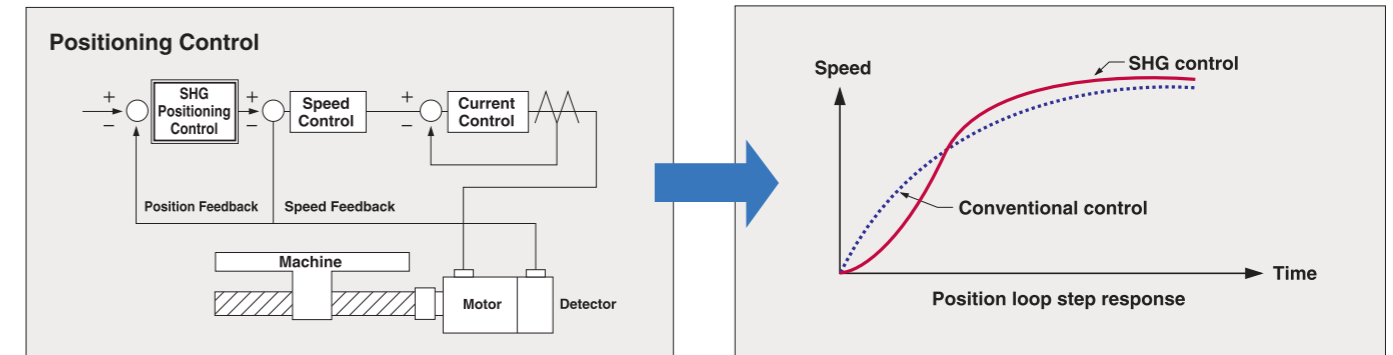

### High Gain Servo Drive

MDS-R dramatically reduces the high frequency motor current ripple through the high response current control and the high frequency PWM control. MDS-R offers the industry's higher level of current control ability of the industry and improves machining accuracy in high-speed cutting. MDS-R has about twice as high current-abilities as conventional models.

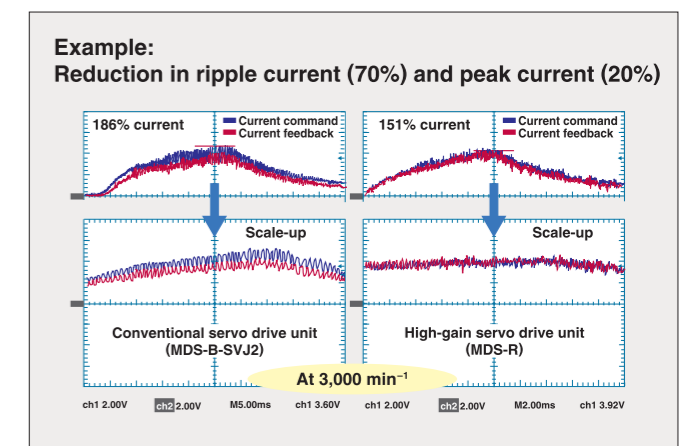

## SERVO automatic tuning plan:

- Improving the stability to derive machine's optimum processing characteristics
- Enhancing the accuracy (by utilizing the mechanical resonance vibration filter adjustment)

- Feature 1) Analysis of mechanical features (inertia cycle features)
- Feature 2) Adjustment according to the analysis results of the mechanical features

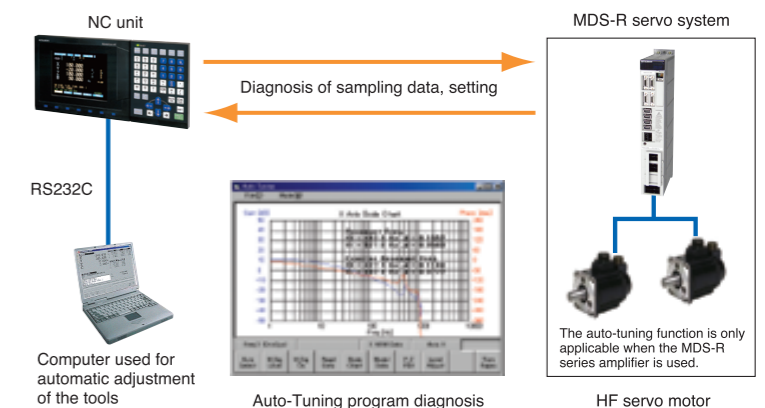

# Features

## High-accuracy control functions (supported by E68 for Milling machine)

The following functions will help you eliminate delays in the control and servo systems. Especially in high-speed machining, they realize further accurate machining and machining time reduction.

### Acceleration/Deceleration before interpolation

By performing acceleration/deceleration before interpolation, the machining shape error can be eliminated with smoothing to achieve highly accurate path. In a circular command, the radius reduction error can be significantly minimized. Furthermore, owing to the feed forward control that is unique to this NC system, stable servo control is realized with extremely small servo error.

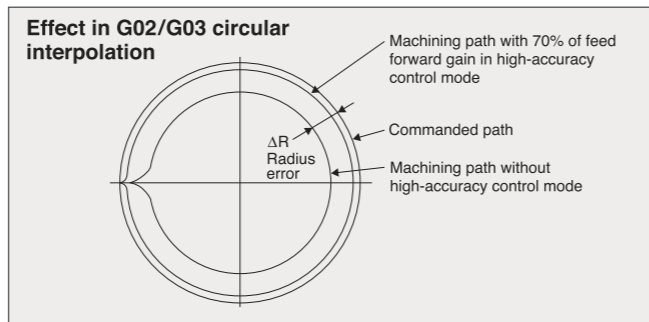

### Optimum corner deceleration

By determining the command vector in the machining program and thereby performing corner deceleration, it is possible to machine workpiece with a high-edge accuracy. The figure on the right shows the pattern of the deceleration speed at the corners.

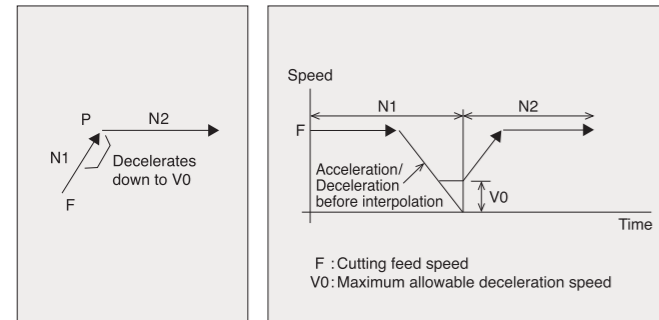

### Vector accuracy interpolation

Even when the commanded path is quite smooth (interval between blocks is short, and corner angles are extremely small), interpolation will be applied to acquire further smooth path.

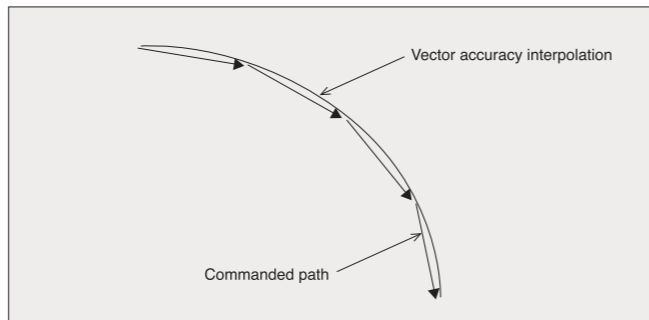

## Synchronous tapping cycle

Complete synchronous control between spindle motor and servo motor will bring you highly accurate tapping.

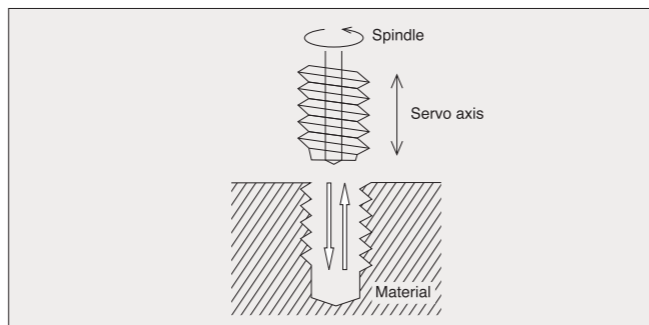

## Memory type pitch error compensation

For further machine accuracy, mechanical error of feeding screw is compensated. You can save compensation interval and amount for each axis in the memory.

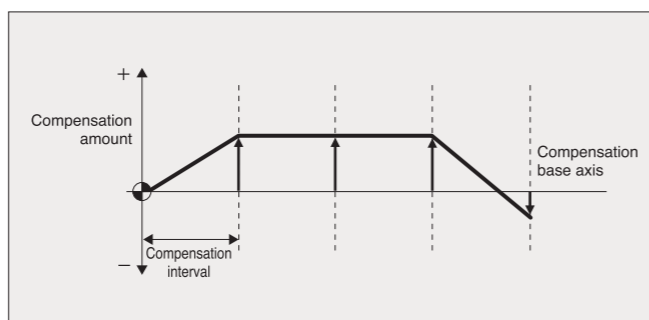

## Circular cutting

(supported by E68 for Milling machine, E60 for Milling machine)

The tool departs from the center of the circle, and by cutting along the inside circumference of the circle, it draws a complete circle, then it returns to the center of the circle.

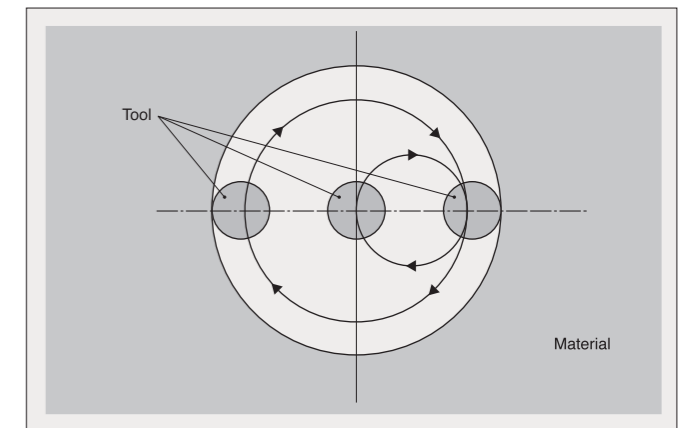

## Scaling

(supported by E68 for Milling machine, E60 for Milling machine)

The shape commanded by the program can be extended or reduced to the desired size by applying a scale factor to the travel axis command value within the range assigned by the scaling command.

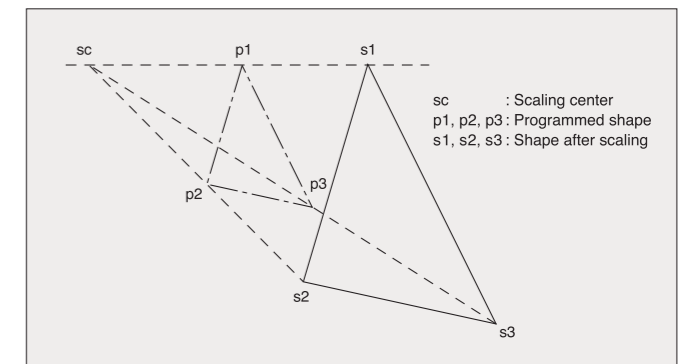

## Coordinate rotation by program

(supported by E68 for Milling machine, E60 for Milling machine)

By designating a rotation angle in the program, actual machining will be performed on the rotated coordinate.

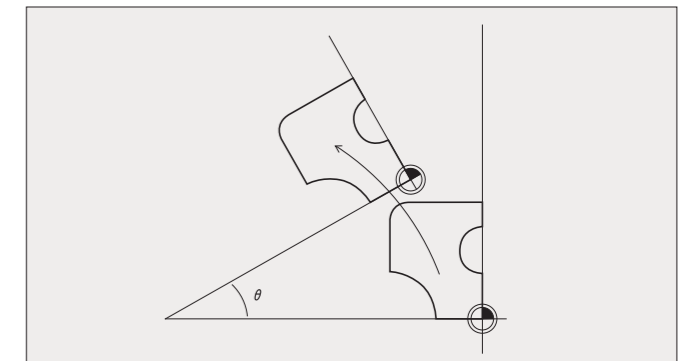

## Corner chamfering/Corner R

At a corner, a commanded linear or arc will be automatically inserted between two travel blocks (G01/G02/G03).

### Corner chamfering

N1 G01 Xx1 Zz1, Cc1;  
N2 Xx2 Zz2;

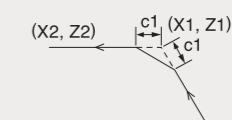

### Corner R

N1 G01 X(x1) Z(z1), R(r1);  
N2 X(x1) Z(z2);

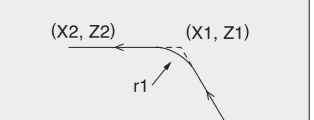

# Features

## Compound type fixed cycle for turning machining (supported by E68 for Lathe machine, E60 for Lathe machine)

With this function, you can easily command rough cutting or thread cutting that normally takes several blocks in turning machining. This function will help you have simple machining programs.

### ■ Rough cutting cycle

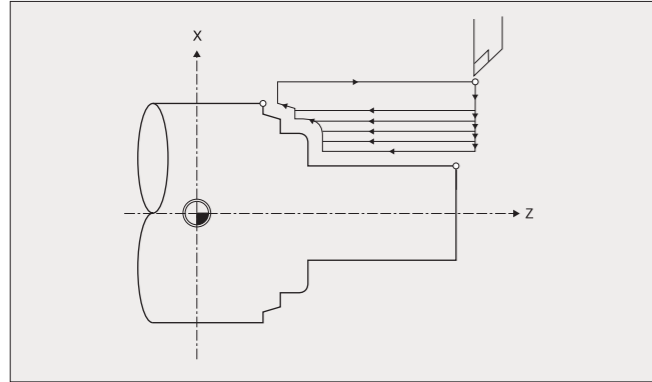

### ■ Thread cutting cycle

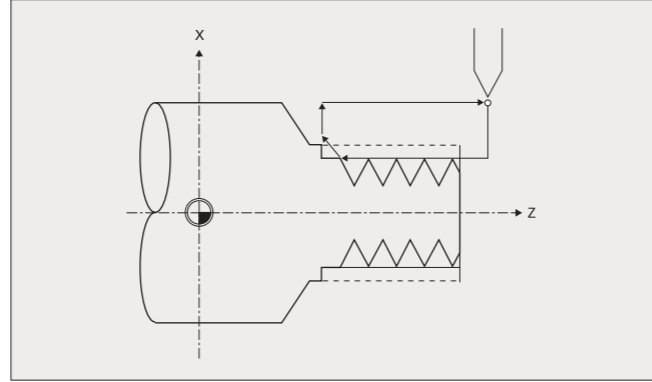

## Chuck barrier and tail stock barrier check (supported by E68 for Lathe machine, E60 for Lathe machine)

By limiting the tool nose point travel range, this function prevents the tool from colliding with the chuck or tail stock because of a programming error. When a travel command exceeding the area set in a given parameter is programmed, the tool is stopped at the barrier boundaries.

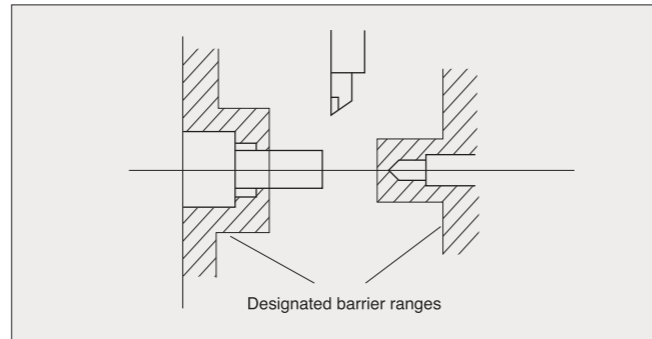

## Inclined axis control (supported by E68 for Lathe machine, E60 for Lathe machine)

In the case such as grinding stone axis of a grinder, even when the angle of the control axis is other than 90°, you can program in the same way as in a rectangular axis. Inclination angle is set by the parameter, and the actual control will be applied by converting travel distance of each axis with the inclination angle.

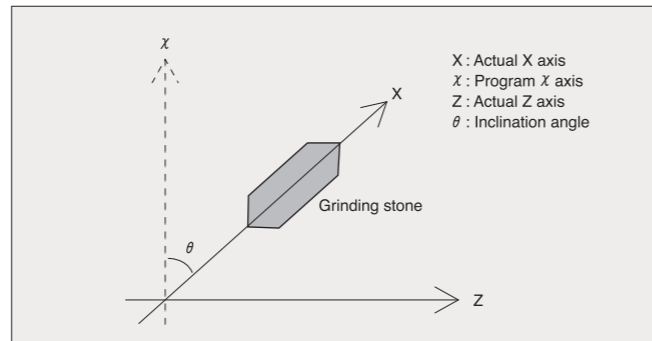

## Tool life management

To manage tools, amount of time and frequency of use of each tool will be accumulated. In addition, usable tools will be selected from a designated group of spare tools.

[TOOL LIFE]		TOOL		4.1/2		
GROUP	TOOL NO.	ST FORM	L-CMP	R-CMP	AUX LIFE	USED
HEAD:	10000000	12345678	1 000	-345.678	100.000	12345 234 34 (min)
NEXT:	80000000	87654321	0 000	45.678	30.000	12345 234 4 (min)
[GROUP LIST]						
10	20	30	40	50	60	70 80 90
100	200	300	400	500	600	700 800 900
1000	2000	3000	4000	5000	6000	7000 8000 9000
10000	20000	30000	40000	50000	60000	70000 80000 90000
100000	200000	300000	400000	500000	600000	700000 800000 900000
1000000	2000000	3000000	4000000	5000000	6000000	7000000 8000000 9000000
10000000	20000000	30000000	40000000	50000000	60000000	70000000 80000000 90000000

## Greatly Improved Display Performance and Ease of Use Enhanced Operability and Viewability

### Coordinate Data Conversion

The displayed coordinate data can be converted into not only programming data, but also another coordinate data with workpiece coordinates or tool offset taken into account.

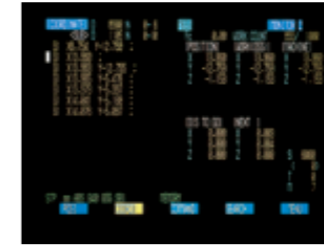

### Word Editing

In addition to conventional editing functions, word-based program editing is now selectable. This function allows deletion, replacement, and insertion on a word basis, making programming much easier.

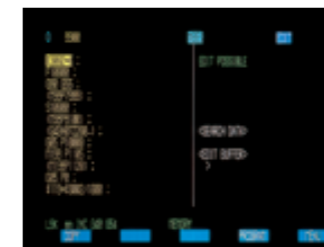

### Graphic Tracing Function

This function enables graphic tracing with the tool path coordinate data, which reflect the workpiece coordinates and tool offset.

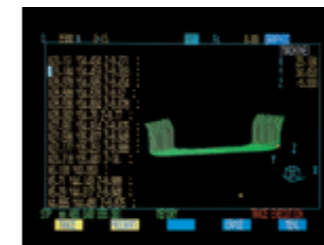

### Buffer Modification

When a program error occurs during automatic or MDI operations, this function enables correction of the error block by a single blockhalt, and the operation to be restarted without resetting NC.



### Waveform Display

Changes in spindle and servo conditions can be displayed by two channels simultaneously. Also, during synchronized tapping, deviations in main and tapping spindle positions (synchronization error) can be indicated in waveforms.

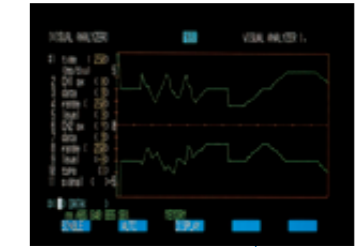

### Interface Diagnosis

This display facilitates monitoring and setting of register data and various signals used in PLC.

# Features

## User-friendly Programming Software makes Your System Development Very Simple and Easy

Mitsubishi MELSOFT is comprehensive FA software that is widely used in various FA stages (design, operation and maintenance). Featuring a wide variety of functions and excellent operability, this software is compatible with all series of Mitsubishi MELSEC PLC to facilitate your system development.



### MELSEC-Like User-Friendly Operation

Ideal system development environments are available through the use of the user-friendly MELSEC programming tool MELSOFT, ranging from specification examination to daily data collection.

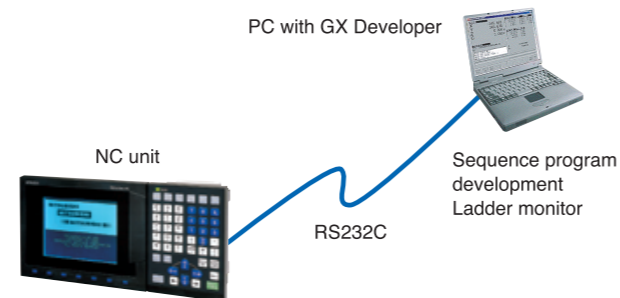

### GX Developer

Compatible with Windows 95/98/2000/NT4.0/Me, this tool allows easy design and debugging through user-friendly Windows applications. If it is used with Simulator or various other utilities, programming efficiency will be further increased.

There are some limitations of available commands with MELDAS. For the details, refer to the instruction manual.

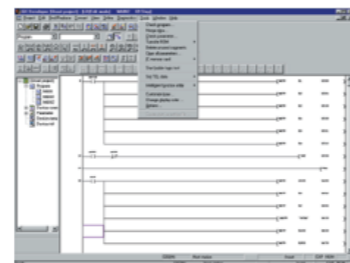

### GX Converter

Enables Excel (CSV) and text file data to be used for GX Developer. Also, converts command lists and device comments edited with GX Developer into Excel data or text format.

Windows and Excel are trademarks of Microsoft (U.S.A) registered in U.S.A. and other countries.

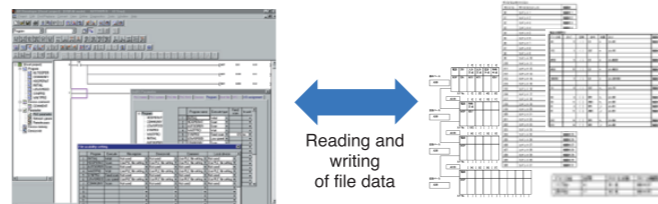

### PLC On-board

PLC ladder editing and monitoring can be done with the Communication Terminal increasing efficiency in debugging and maintenance.



# System Configuration

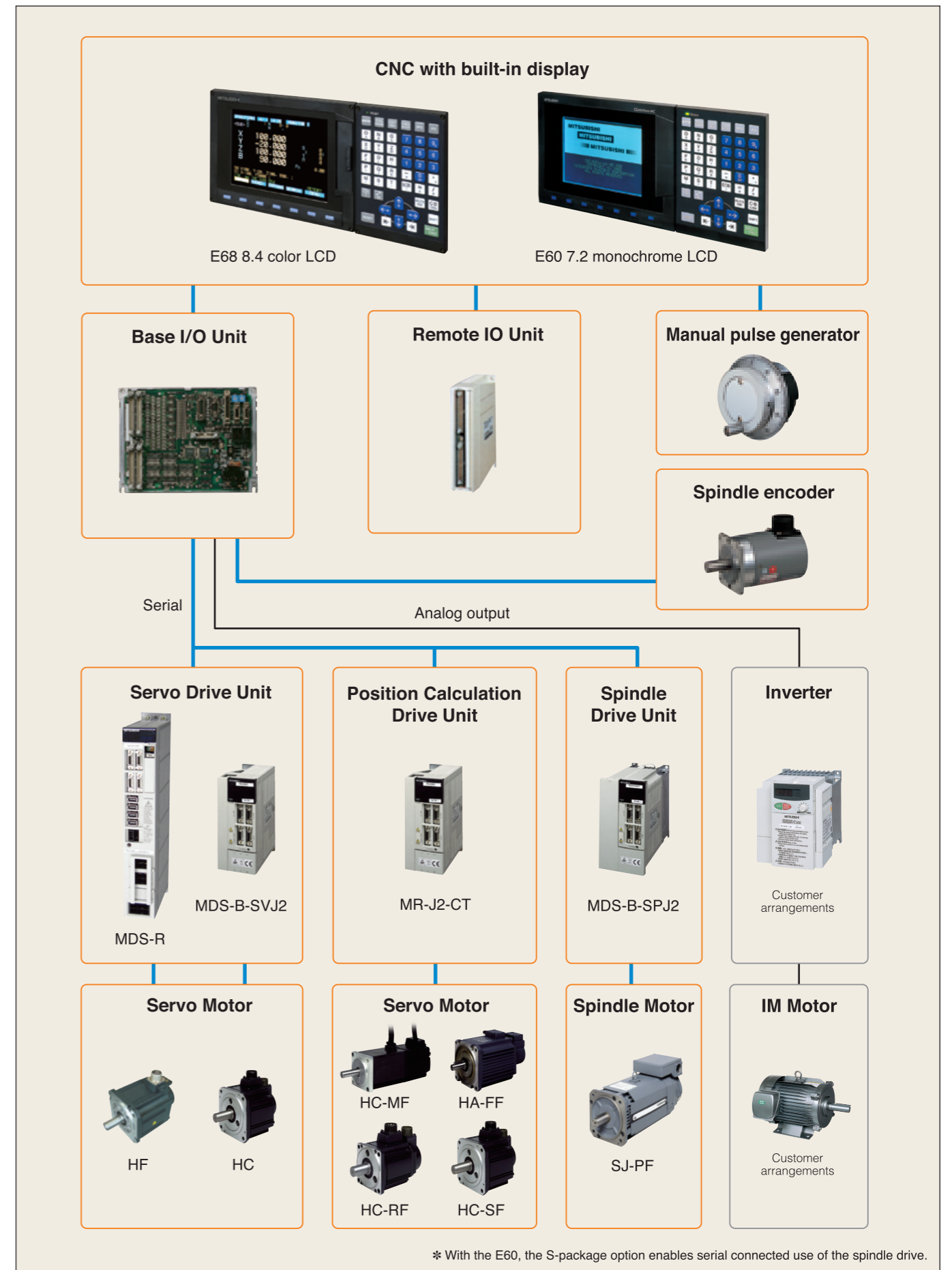

\* With the E60, the S-package option enables serial connected use of the spindle drive.

# Drive System

## High Cost-Performance Servo Drive MDS-R Series

- Excellent cost-performance is achieved by adopting resistance regeneration type and 2-axis-integrated servo drive.
- High-speed current control (High-gain control I) and Smooth high-gain (SHG) control contribute to high-speed high-accuracy machining.



MDS-R

## Small-Capacity, Compact Servo/Spindle Drive MDS-B-SVJ2/SPJ2 Series

- Ultra-compact drive unit, which has built-in power supply, contributes to the reduction in size of control panels.
  - The height is 168mm for 0.1 to 2kW servo and 0.2 to 3.7kW spindle units.
  - The height is 250mm for 5.5 to 7.5kW spindle units.
  - The height is 380mm for 11kW spindle unit.
- Smooth high-gain (SHG) control contributes to high-speed high-accuracy machining.



MDS-B-SVJ2



MDS-B-SPJ2

## Servo Motor for Basic Feed Axis

### HF Series (supported by MDS-R Series)

- Medium-inertia, high-accuracy and high-speed servo motor
- Accuracy of a high-inertia machine ensured. Optimal for a machine with high acceleration.
- Lineup: 0.5 to 3.5kW
- Maximum rotation speed: 3,000r/min
- Adaptable to the detector at 1 million P/rev

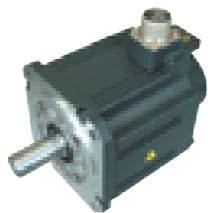

### HC Series (supported by MDS-B-SVJ2)

- Medium-inertia and high-accuracy servo motor
- Optimal for ensuring the accuracy of a machine with high-inertia.
- Lineup: 0.5 to 3.5kW
- Maximum rotation speed: 3,000r/min
- Adaptable to the standard detector at 0.1 million P/rev



## High-efficiency Spindle Motor SJ-P/PF Series

We offer you a broad lineup to support various types of machine tools.

### Lineup

- Small capacity and compact SJ-P series: 0.2 to 3.7kW
- Compact SJ-PF series: 0.75 to 11kW



## Servo Drive with Built-in Indexing Function MR-J2-CT Series

With built-in index/positioning functions, this unit can be applied to turret indexing or tool magazine indexing.



MR-J2-CT

### Servo Motor for Auxiliary Axis

Model name	Type name	Lineup	Max. speed	Detector
Ultra-low-inertia small-capacity	HC-MF	0.05 to 0.75kW	4500r/min	16384P/rev
Low-inertia small-capacity	HA-FF	0.05 to 0.6kW	4000r/min	8192P/rev
Low-inertia medium-capacity	HC-RF	1 to 2kW	4500r/min	16384P/rev
Medium-inertia medium-capacity	HC-SF	0.5 to 3.5kW	3000r/min	16384P/rev

# System Specifications

	E60		E68	
	Lathe machine	Milling machine	Lathe machine	Milling machine
Maximum number of control axes	5	5	8	8
Maximum number of NC axes	2 (X, Z)	3 (X, Y, Z)	2 (X, Z)	3 (X, Y, Z)
Maximum number of spindles	1 (Standard: Analog) (S-Package: Serial)		2 (Serial)	
Maximum number of PLC axes	1		2	
Auxiliary axes (MR-J2-CT)	1		4	
Maximum number of systems	1			
Number of simultaneous contouring control axes	3		4	
Minimum control unit	1 $\mu$ m		1 $\mu$ m 0.1 $\mu$ m (option)	
Built-in PLC capacity (number of steps)	4000		6000 16000 (option)	
PLC development tools	GX Developer (MELSEC development tools)			
Program memory capacity	600m/400 programs (equivalent to 236,000 words)			
Display	7.2-inch monochrome LCD		8.4-inch color TFT	
Drive motor capacity	Servo motor capacity	0.5 to 3.5kW		
	Spindle motor capacity	0.2 to 11kW (E68, E60 S-package)		
Maximum number of inputs/outputs	Machine input/output	256/240 point (one analog output)	256/240 point (one analog output) 256/256 point	
	Operation board	128/128 point		
Analog output points	for inverter	1	1	

# Overseas Service Network

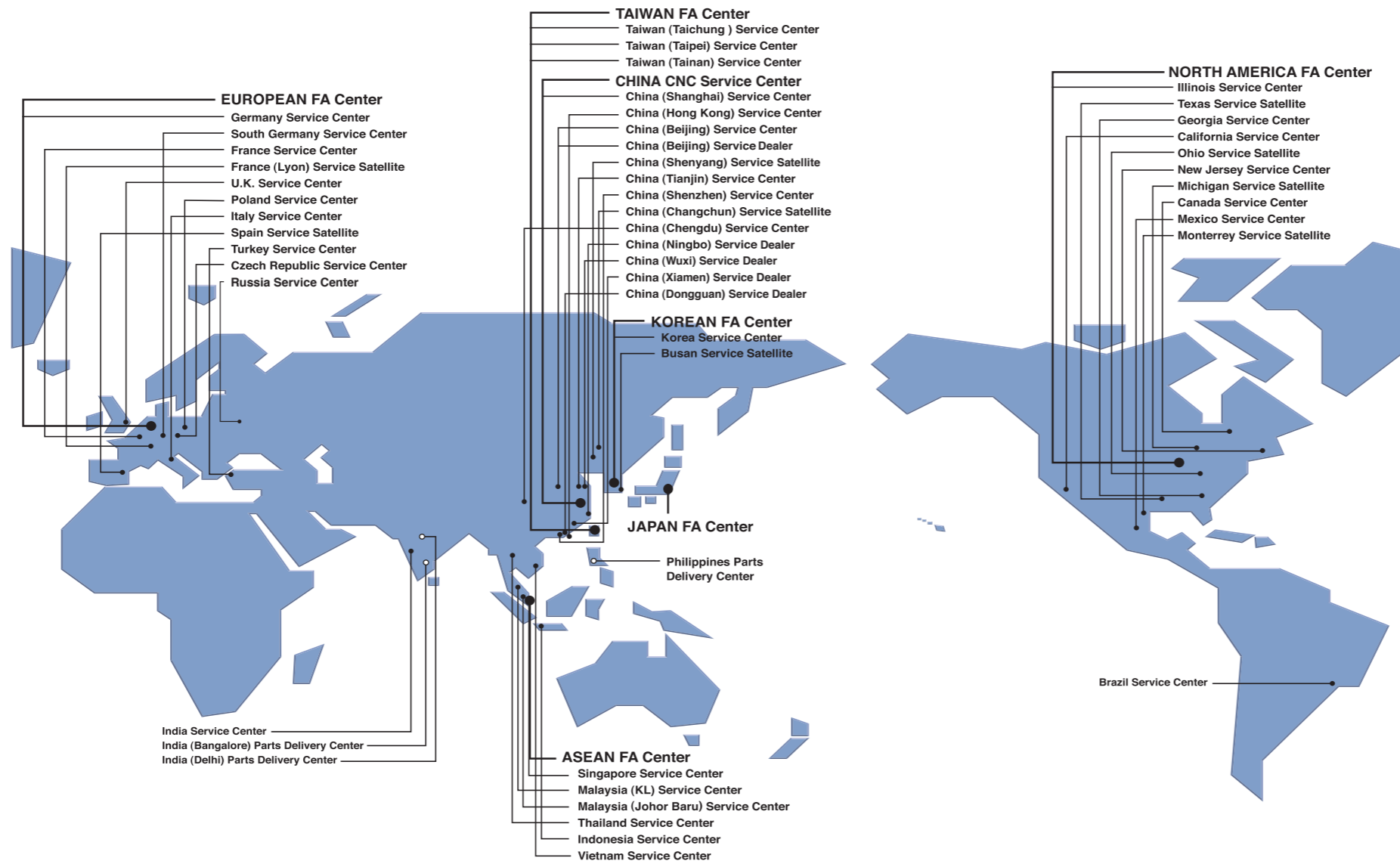

## ■ NORTH AMERICA FA Center (MITSUBISHI ELECTRIC AUTOMATION INC.)

**Illinois Service Center**  
500 CORPORATE WOODS PARKWAY, VERNON HILLS, ILLINOIS 60061, U.S.A.  
TEL: +1-847-478-2500 / FAX: +1-847-478-2650

**Michigan Service Satellite**  
TEL: +1-847-478-2617 / FAX: +1-269-673-4092

**Texas Service Satellite**  
TEL: +1-817-251-7468 / FAX: +1-817-416-1439

**California Service Center**  
5665 PLAZA DRIVE, CYPRESS, CALIFORNIA 90630, U.S.A.  
TEL: +1-714-220-4796 / FAX: +1-714-229-3818

**Georgia Service Center**  
2810 PREMIERE PARKWAY, SUITE 400 DULUTH GEORGIA 30097, U.S.A.  
TEL: +1-678-258-4500 / FAX: +1-678-258-4598

**Ohio Service Satellite**  
TEL: +1-847-478-2608 / FAX: +1-847-478-2608

**New Jersey Service Center**  
VANTAGE COURT SOUTH 200 COTTONTAIL LANE, SOMERSET, NEW JERSEY 08873, U.S.A.  
TEL: +1-732-560-4500 / FAX: +1-732-560-4531

**Canada Service Center**  
4229 14TH AVENUE MARKHAM, ONTARIO L3R OJ2, CANADA  
TEL: +1-905-475-7728 / FAX: +1-905-475-7935

**Mexico Service Center**  
MARIANO ESCOBEDO 69 TLALNEPANTLA, 54030 EDO. DE MEXICO  
TEL: +52-55-9171-7662 / FAX: +52-55-9171-7649

**Monterrey Service Satellite**  
TEL: +52-81-8365-4171 / FAX: +52-55-9171-7649

**Brazil Service Center**  
ACESSO JOSE SARTORELLI, KM 2.1 18550-000 BOITUVA-SP, BRAZIL  
TEL: +55-15-3363-9900 / FAX: +55-15-3363-9911

## ■ ASEAN FA Center (MITSUBISHI ELECTRIC ASIA PTE., LTD.)

**Singapore Service Center**  
307 ALEXANDRA ROAD #05-01/02 MITSUBISHI ELECTRIC BUILDING SINGAPORE 159943  
TEL: +65-6473-2308 / FAX: +65-6476-7439

**Thailand Service Center**  
BANG-CHAN INDUSTRIAL ESTATE NO.111 MOO 4, SERITHAI RD., T.KANNAYAO, A.KANNAYAO, BANGKOK 10230, THAILAND  
TEL: +66-2-517-1326, +66-2-919-9873 / FAX: +66-2-919-8717

**India Service Center**  
B-36FF, PAVANA INDUSTRIAL PREMISES, M.I.D.C., BHOSARI PUNE 411026, INDIA  
TEL: +91-20-2711-9484 / FAX: +91-20-2712-8115

**India (Bangalore) Parts Delivery Center**  
TEL: +91-80-328-3030

**India (Delhi) Parts Delivery Center**  
TEL: +91-11-682-4389

**Malaysia (KL) Service Center**  
60 JALAN USJ 10/1B 47620 UEP SUBANG JAYA SELANGOR DARUL EHSAN, MALAYSIA  
TEL: +60-3-5631-7605 / FAX: +60-3-5631-7636

**Malaysia (Johor Baru) Service Center**  
NO.16 JALAN SHAHBANDAR 1, TAMAN UNGKU TUN AMINAH, 81300 SKUDAI JOHOR, MALAYSIA  
TEL: +60-7-557-8218 / FAX: +60-7-557-3404

**Indonesia Service Center**  
WISMA NUSANTARA 14TH FLOOR, JL. M.H. THAMRIN 59, JAKARTA 10350, INDONESIA  
TEL: +62-21-3917-144 / FAX: +62-21-3917-164

**Philippines Parts Delivery Center**  
UNIT No.411, ALABANG CORPORATE CENTER KM 25. WEST SERVICE ROAD SOUTH SUPERHIGHWAY, ALABANG MUNTINLUPA METRO MANILA, PHILIPPINES 1771  
TEL: +63-2-807-2416 / FAX: +63-2-807-2417

**Vietnam Service Center**  
47-49 HOANG SA STREET, DAKAO WARD, DISTRICT 1, HO CHI MINH CITY, VIETNAM  
TEL: +84-8-910-4763 / FAX: +84-8-910-2593

## ■ EUROPEAN FA Center (MITSUBISHI ELECTRIC EUROPE B.V.)

**GOTHAER STRASSE 10, 40880 RATINGEN, GERMANY**  
TEL: +49-2102-486-1850 / FAX: +49-2102-486-5910

**Germany Service Center**  
GOTHAER STRASSE 10, 40880 RATINGEN, GERMANY  
TEL: +49-2102-486-1850 / FAX: +49-2102-486-5910

**South Germany Service Center**  
KURZE STRASSE, 40, 3RD FLOOR, 70794 FILDERSSTADT, GERMANY  
TEL: +49-711-3270-010 / FAX: +49-711-3270-0141

**U.K. Service Center**  
TRAVELLERS LANE, HATFIELD, HERTFORDSHIRE AL10 8XB, U.K.  
TEL: +44-1707-28-2846 / FAX: +44-1707-27-8992

**France Service Center**  
25, BOULEVARD DES BOUVETS, 92741 NANTERRE CEDEX FRANCE  
TEL: +33-1-41-02-83-20 / FAX: +33-1-49-01-07-25

**France (Lyon) Service Satellite**  
TEL: +33-1-41-02-83-20 / FAX: +33-1-49-01-07-25

**Italy Service Center**  
VIA ARCHIMEDE 35, 20041 AGRATE BRIANZA (MI) ITALY  
TEL: +39-039-6053-342 / FAX: +39-039-6053-206

**Poland Service Center**  
UL SLICZNA 36, 31-444 KRAKOW, POLAND  
TEL: +48-12-632-28-85 / FAX: +48-12-632-47-82

**Spain Service Satellite**  
CTRA. DE RUBI, 76-80 - APDO. 420, 08190 SANT CUGAT DEL VALLES (BARCELONA) SPAIN  
TEL: +34-935-65-2236 / FAX: +34-935-89-1579

**Turkey Service Center**  
DARULACEZE CAD. FAMAS IS MERKEZI A BLOCK NO.43 KAT:2 80270 OKMEYDANI ISTANBUL, TURKEY  
TEL: +90-212-320-1640 / FAX: +90-212-320-1649

**Czech Republic Service Center**  
NEMOCNICNI 12, 702 00 OSTRAVA 2 CZECH REPUBLIC  
TEL: +420-596-152-426 / FAX: +420-596-152-112

**Russia Service Center**  
213, B.Novodmitrovskaya Str., 14/2 Moscow, Russia  
TEL: +7-495-748-01-91 / FAX: +7-495-748-01-92

## ■ NORTH AMERICA FA Center

**Illinois Service Center**

**Texas Service Satellite**

**Georgia Service Center**

**California Service Center**

**Ohio Service Satellite**

**New Jersey Service Center**

**Michigan Service Satellite**

**Canada Service Center**

**Mexico Service Center**

**Monterrey Service Satellite**

**Brazil Service Center**

## ■ CHINA CNC Service Center (MITSUBISHI ELECTRIC AUTOMATION (SHANGHAI) LTD.)

**China (Shanghai) Service Center**  
4/F, ZHI FU PLAZA, No.80 XIN CHANG ROAD, HUANG PU DISTRICT, SHANGHAI 200003, CHINA  
TEL: +86-21-6120-0808 / FAX: +86-21-6494-0178

**China (Ningbo) Service Dealer**

**China (Wuxi) Service Dealer**

**China (Beijing) Service Center**  
9/F, OFFICE TOWER 1, HENDERSON CENTER, 18 JIANGUOMENNEI DAJIE, DONGCHENG DISTRICT, BEIJING 100005, CHINA  
TEL: +86-10-6518-8830 / FAX: +86-10-6518-3907

**China (Beijing) Service Dealer**

**China (Tianjin) Service Center**  
B-2 801/802, YOUYI BUILDING, No.50 YOUYI ROAD, HEXI DISTRICT, TIANJIN 300061, CHINA  
TEL: +86-22-2813-1015 / FAX: +86-22-2813-1017

**China (Shenyang) Service Satellite**

**China (Changchun) Service Satellite**

**China (Chengdu) Service Center**  
BLOCK B-1, 23F, CHUAN XIN MANSION, 18 SECTION 2, RENMIN ROAD SOUTH, CHENGDU, SICHUAN, 610016, CHINA  
TEL: +86-28-8619-9730 / FAX: +86-28-8619-9805

**China (Hong Kong) Service Center (MITSUBISHI ELECTRIC AUTOMATION (HONG KONG) LTD.)**  
UNIT A, 25/F, RYODEN INDUSTRIAL CENTRE, 26-38 TA CHUEN PING STREET, KWAI CHUNG, N.T., HONG KONG  
TEL: +852-2619-8588 / FAX: +852-2784-1323

**China (Shenzhen) Service Center**  
RM02, UNIT A, 13/F, TIANAN INTERNATIONAL BUILDING, RENMIN ROAD SOUTH, SHENZHEN 518005, CHINA  
TEL: +86-755-2515-6691 / FAX: +86-755-8229-3686

**China (Xiamen) Service Dealer**

**China (Dongguan) Service Dealer**

## ■ KOREAN FA Center (MITSUBISHI ELECTRIC AUTOMATION KOREA CO., LTD.)

**Korea Service Center**  
1480-6, GAYANG-DONG, GANGSEO-GU, SEOUL 157-200 KOREA  
TEL: +82-2-3663-0473 / FAX: +82-2-3663-0475

**Busan Service Satellite**

## ■ TAIWAN FA Center (MITSUBISHI ELECTRIC TAIWAN CO., LTD.)

**Taiwan (Taichung) Service Center**  
No.8, GONG YEH 16TH RD., TAICHUNG INDUSTRIAL PARK TAICHUNG CITY, TAIWAN  
TEL: +886-4-2359-0688 / FAX: +886-4-2359-0689

**Taiwan (Taipei) Service Center**  
3TH. FLOOR, NO. 122 WUKUNG 2ND, RD., WU-KU HSIANG, TAIPEI HSIEN, TAIWAN  
TEL: +886-2-2299-2205 / FAX: +886-2-2298-1909

**Taiwan (Tainan) Service Center**  
2F(C), 1-1, CHUNGHWA-RD, YONGKANG CITY, TAINAN HSIEN, TAIWAN  
TEL: +886-6-313-9600 / FAX: +886-6-313-7173