

Intelligent Transport Systems Edition

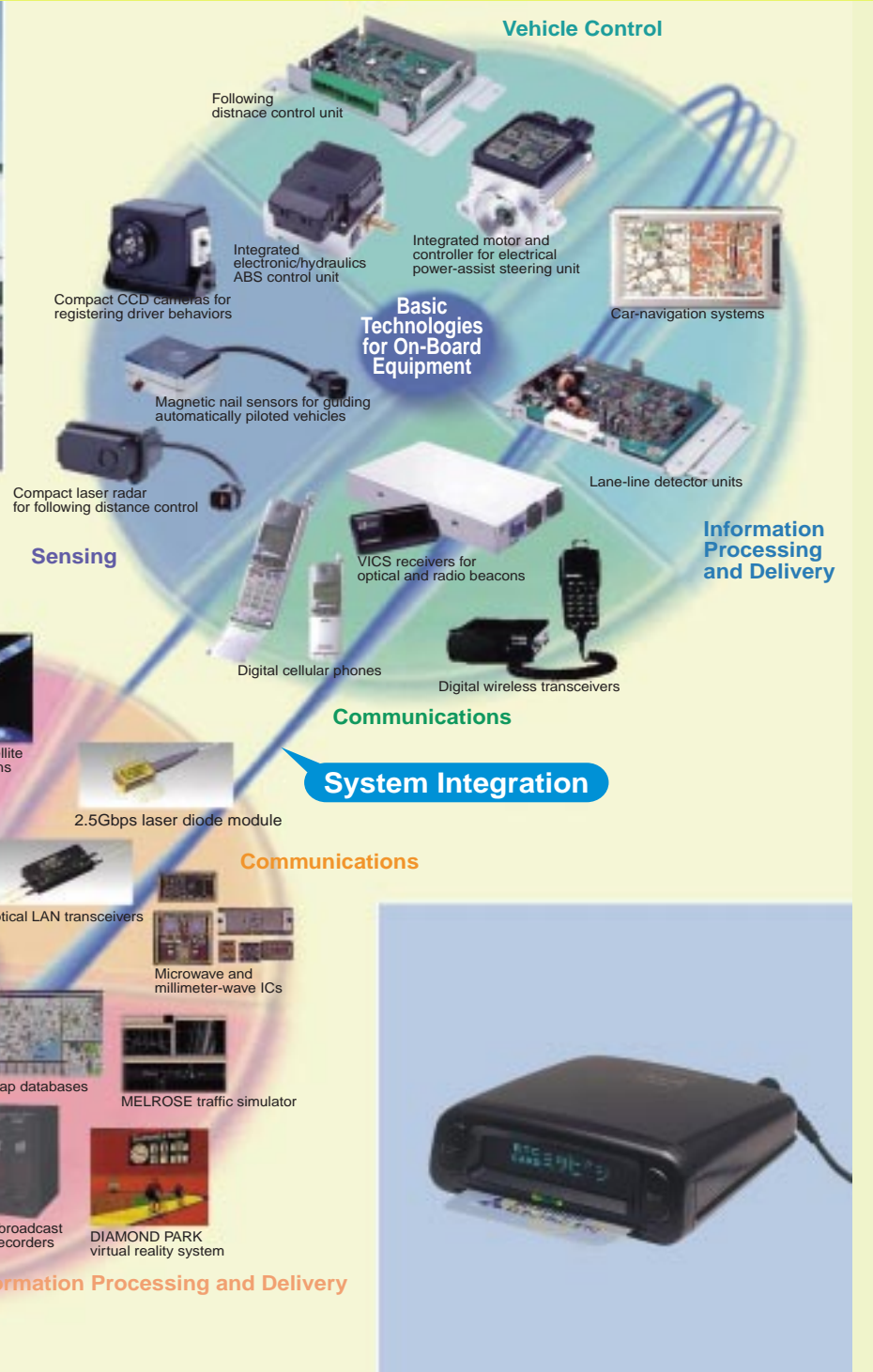

## Intelligent Transport Systems Edition

### CONTENTS

#### TECHNICAL REPORTS

##### OVERVIEW

**Intelligent Transport Systems, Symbols of the 21st Century** ..... 1  
*by Ichiro Masaki*

**Recent Trends and Mitsubishi Achievements in ITS Technology** ..... 2  
*by Masayuki Oishi and Shoichi Washino*

**Car-Navigation Systems** ..... 10  
*by Kazuhiro Yokouchi, Hiroaki Ideno and Masako Ota*

**Electronic Toll-Collection Systems** ..... 15  
*by Hiromitsu Kato and Yuji Hirooka*

**Advanced Cruise-Assist Highway Systems** ..... 21  
*by Tetsuo Miyoshi and Akira Horiguchi*

**Simulation Environment for Intelligent Transport Systems** ..... 26  
*by Hiroyuki Kumazawa and Masayuki Oishi*

**MELBA Enterprise Application Integration Software Using Agent Technology** ..... 29  
*by Shigenori Kino and Yoshitaka Ogawa*

#### MITSUBISHI ELECTRIC OVERSEAS NETWORK

The oval area at the upper right of our cover for the Intelligent Transportation Systems (ITS) edition of "Advance" shows Mitsubishi Electric's key technologies and representative in-vehicle product categories, while that at the lower left shows those for the ITS infrastructure. For example, semiconductor and electronic technology includes the artificial retina chip and units for controlling engines and vehicles. The elongated ellipse joining the two areas represents the corporation's sophisticated capabilities in systems integration.

The photograph at the upper left shows the installation for an electronic toll-collection system and that at the lower right the corresponding in-vehicle transceiver unit. Superior systems integration ensures that not only the individual products but also the entire system will be robust and provide the very highest performance.

#### Editor-in-Chief

Shin Suzuki

#### Editorial Advisors

Haruki Nakamura  
Hiroo Fujikawa  
Keizo Hama  
Kazunori Sasaki  
Masao Hataya  
Hiroshi Muramatsu  
Takashi Ito  
Takashi Nagamine  
Hiroaki Kawachi  
Hiroshi Kayashima  
Takao Yoshihara  
Osamu Matsumoto  
Kazuharu Nishitani

#### Vol. 91 Feature Articles Editor

Shoichi Washino

#### Editorial Inquiries

Keizo Hama  
Corporate Total Productivity Management  
& Environmental Programs  
Mitsubishi Electric Corporation  
2-2-3 Marunouchi  
Chiyoda-ku, Tokyo 100-8310, Japan  
Fax 03-3218-2465

#### Product Inquiries

Yasuhiko Kase  
Global Strategic Planning Dept.  
Corporate Marketing Group  
Mitsubishi Electric Corporation  
2-2-3 Marunouchi  
Chiyoda-ku, Tokyo 100-8310, Japan  
Fax 03-3218-3455

Mitsubishi Electric Advance is published on line quarterly (in March, June, September, and December) by Mitsubishi Electric Corporation.  
Copyright © 2000 by Mitsubishi Electric Corporation; all rights reserved.  
Printed in Japan.

# Overview

*Intelligent Transport Systems, Symbols of the 21st Century.*



*by Ichiro Masaki\**

**T**he goal of an Intelligent Transport System (ITS) is to increase the safety and efficiency of transport systems by integrating various subsystems, including cars, trains and traffic-control systems. Information technologies for sensing, communication and control are the keys to successful integration. Examples of ITS include navigation systems, electric toll-collection systems and traffic-signal control systems for emergency vehicles. The navigation system indicates the best route to the destination based on real-time traffic-congestion information. Electric toll collection allows cars to go through toll gates without stopping by handling toll payment electronically. With an advanced traffic-signal control system, signals turn green when an emergency vehicle approaches them. The ITS is expected to lead to changes in business, academia, and life styles as we leave the twentieth century for the twenty-first.

Various industrial products, such as refrigerators, TV sets and IC chips have been developed since the industrial revolution, but ITS is not just another new product; it represents a new business paradigm. With the conventional business paradigm, companies compete to achieve better performance, cost, and reliability in accordance with a stable, long-lasting product concept. For example, the product concept of the refrigerator is a low-temperature box with a motor and a compressor, a concept with lengthy validity within which companies have long been competing for higher performance and productivity. The core of the ITS business, in contrast, is to create new product concepts and global standards. Another feature of ITS business is that ITS products are components of large systems and therefore their compatibility is also important. The nature of the ITS business requires new working environments different from those of conventional manufacturing. For example, a team of people with different cultural backgrounds is useful to create new product concepts by integrating component technologies with system designs and technical feasibility with social needs. It is important to establish trends in technologies and lifestyles through international collaboration between governments, industries, and academia. In order to develop a traffic-incident detection system for a tunnel, say, we need not only to work on components such as TV cameras, image processing, and communication networks but also the whole architecture of sensor networks for road administrations as well as trends in international standardization.

Academically, too, ITS represents a new paradigm. In the twentieth century, science was subdivided into a large number of fields in each of which advances were made more or less independently. In the twenty-first century, we need to develop a new style of science that will be able to answer multidisciplinary questions. For example, studies embracing engineering, economics, politics and other related fields are required to answer the question "What type of transport system is suitable for each of various regions?"

ITS will create new lifestyles in the twenty-first century. It is an example of applying information technology to society. Such applications will extend from traffic to medical, financial, educational and other fields. The core of the social infrastructure will grow from electricity and water to the "super infrastructure" which supports the informational aspects of various social activities.

We are now not only leaving behind the twentieth century for the twenty-first but also entering a new, post-industrial era symbolized by ITS.

*\*Prof. Ichiro Masaki is a Principle Research Associate with the Intelligent Transportation Research Center of the Microsystems Technology Laboratories, Massachusetts Institute of Technology.*

# Recent Trends and Mitsubishi Achievements in ITS Technology

by Masayuki Oishi and Shoichi Washino\*

ITS has recently been a popular topic of newspapers and mass media. In 1998, The Japanese government selected ITS as a target for economic development. Because ITS is centered on data transmission, it can offer a demand multiplier twice that of conventional utilities. In November 1998, cabinet ministers named ITS as a key component of future urban transportation systems. The ministers decided to step up the implementation schedule for electronic toll collection (ETC) systems, targeting 2003 for development of "smart" highways and "smart" cars with information capabilities.

Automotive and electrical manufacturers have been taking orders for ETC systems since March

1999 and ITS capabilities are being developed rapidly, with cooperation extended between manufacturers in the same fields as well as across industry lines.

Mitsubishi Electric has set up a ITS promotional department to focus the company's R&D. A special council of the best minds from each of the product divisions meets regularly to set strategy for the new field. These activities are helping to guide the company's policies into an overall plan for ITS development in the years to come.

## Major Trends

1999 was the second year of the Construction Ministry's five-year plan for roadway infrastructure. The plan includes three items directly related to ITS development: inauguration and expansion of ETC services, development of "smart" highway technologies and promotion of ITS solutions to prefectural and local governments. The start of ITS led to a 2.62-fold increase in budgetary allocation for ITS to 64.7 billion yen (Table 1.) The five-year plan calls for ETC support at 60% of the nation's toll plazas—some 730 locations—by 2002. Fig. 1 illustrates the basic components of ETC systems.

Introducing an ETC system can raise the throughput of a toll kiosk from 230 vehicles per hour to 1,000, a better than fourfold increase. This would help to alleviate traffic jams, 30% of

Table 1 Construction Ministry's ITS Budget for 1999 (unit: billion yen)

Category	Payments in FY 98	Payments in FY 99	Multiple
ITS R&D, deployment	24.7	64.7	2.62
ITS infrastructure deployment (largely ETC)	16.5	56.5	3.42
Overall promotion of R&D	8.2	8.2	1.00

**Note:** The Construction Ministry has contributed ¥140 million to another project, "R&D on information and communication technologies for 21st century ITS applications," conducted jointly with the Ministries of Transport and of Posts and Telecommunications. (Source: "Summary of Roadway Related Budget for FY '99")

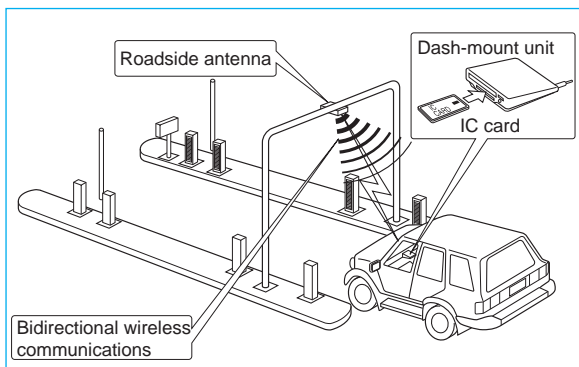

(Source: "ITS Guide")

Fig. 1 Illustration of ETC system.

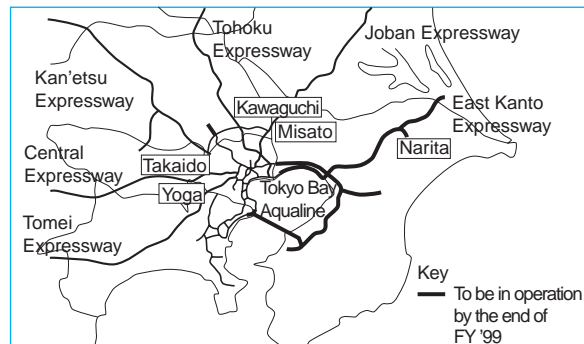

(Source: "ITS Guide")

Fig. 2 Major roads to be serviced by ETC systems in FY '99. (This list is not complete.)

\*Masayuki Oishi is with ITS Business Development Group and Shoichi Washino is with Industrial Electronics @ Systems Laboratory.

which are believed to originate at overloaded toll plazas.

Under the ministry's plan, a prototype system was implemented on the main roads of Chiba prefecture in 1999, see Fig. 2.

**"Smart" Highway Concept**

The Japanese government designated ITS technology as one of the targets for an emergency economic stimulus package passed in November 1998. The government ordered early introduction of ETC systems and tests on "smart" highways incorporating intelligent functions and "smart" cars.

Smart highways include a system for communications between roadway and vehicle, an optical fiber communications trunk and various sensors. This infrastructure will support a diversity of ITS services. Smart highways are ITS-capable highways. Fig. 3 illustrates the concept.

The development schedule is as follows: testing of Advanced cruise-assisted Highway Systems (AHS) will be completed in 2000, systems and regulations will be drafted by 2001, and by 2003, the technologies will be initially deployed on the No. 2 Tomei Expressway (Tokyo to Nagoya), Meishin Expressway (Nagoya to Kobe) and on intraurban freeways. The plan calls for to be introduced to all major roads in the nation to be upgraded with intelligent capabilities by the year 2015.

**ITS Information and Communications Systems**

The ITS Information and Communication Sys-

tems Committee of the Telecommunications Technology Council investigated information technology for ITS applications, delivering its findings to the Minister for Posts and Telecom-

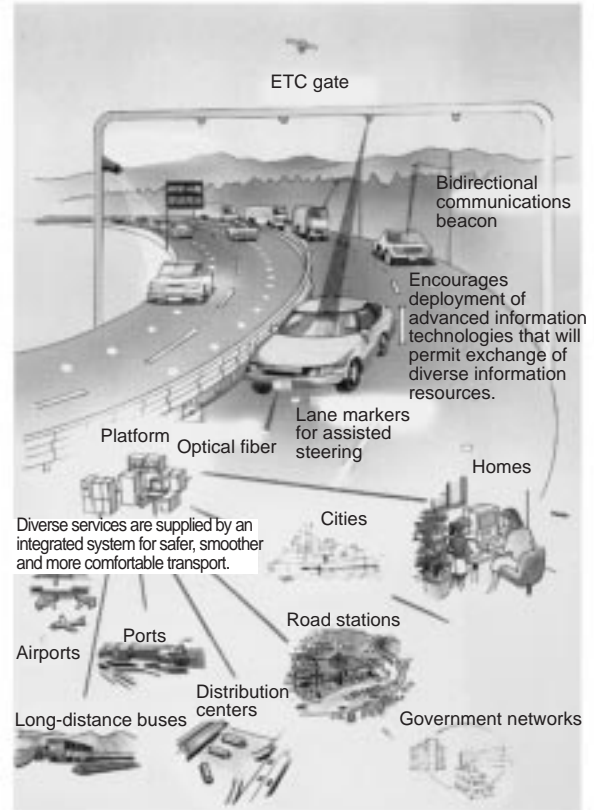

(Source: "ITS Guide")

Fig. 3 "Smart" highway with ITS capabilities.

Table 2 ITS Applications Examples

Field	Application
Roadway traffic data related	<ul style="list-style-type: none"> <li>* Request-driven navigation systems</li> <li>* Optimum route guidance systems</li> <li>* Parking availability data and reservation services</li> <li>* Traffic jam locations and estimated travel times</li> </ul>
ETC and DSRC related	<ul style="list-style-type: none"> <li>* ETC systems</li> <li>* Gas station payment settlement system</li> <li>* Parking garage management systems</li> <li>* Systems for convenience stores and drive-through shopping</li> <li>* Tag management systems for cargo handling in distribution centers</li> </ul>
Car multimedia related	<ul style="list-style-type: none"> <li>* Destination information systems</li> <li>* Reservation systems</li> <li>* Electronic secretary systems for vehicle use</li> <li>* Entertainment information systems</li> </ul>
Distribution and public transport related	<ul style="list-style-type: none"> <li>* Optimum realtime fleet dispatch management systems</li> <li>* Commercial vehicle locating systems</li> <li>* Vehicle management system for public transport</li> <li>* User information systems for public transport</li> </ul>
Driver assistance and driving safety enhancement related	<ul style="list-style-type: none"> <li>* Intersection warning systems</li> <li>* Autopilot systems for commercial vehicles</li> <li>* Stolen vehicle tracking systems</li> <li>* Immediate automatic accident reporting</li> </ul>

(Source: "Report of the ITS Information and Communication Systems Committee")

munications in February 1999. We summarize the findings as follows:

**THE PROMISE OF ITS TECHNOLOGY.** ITS is a comprehensive communication system dealing with roadway conditions and traffic behavior, and offering potential to ease traffic bottlenecks, reduce accident incidence and improve the transport efficiency of the nation's roadway networks.

ITS will affect the operation of the nation's approximately 70 million motor vehicles and contribute to the development of the automotive and electronics industries, bringing economic growth and creating new industries.

In an age where roadway travel is central to the transportation network and a significant part of everyday living, ITS will improve the lives of a citizens by improving the quality of travel. ITS will also serve as a step toward an information-intensive society.

ITS will contribute to regional development by providing information transmissions for the region that make life easier.

ITS is a major project being pursued simultaneously in Japan, the US, and in Europe, and Japan has an opportunity to lead the way in technical development and in the establishment of international standards.

**APPLICATION EXAMPLES AND DEVELOPMENT IDEALS.** Table 2 lists applications in five fields familiar to everyday life. We expect the initial phases of deployment to last to 2005, wider expansion to follow until 2010 when the market will mature (Fig. 4.)

**ITS MARKET.** Establishment of infrastructure and wide availability of terminals will serve to kindle the market into what will grow to be a huge ITS related industry. The diversity of appli-

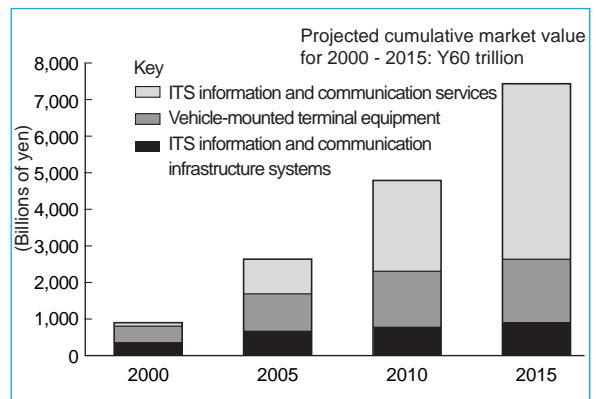

(Source: "Report of the ITS Information and Communication System Committee")

Fig. 5 Epic growth projected in the ITS market.

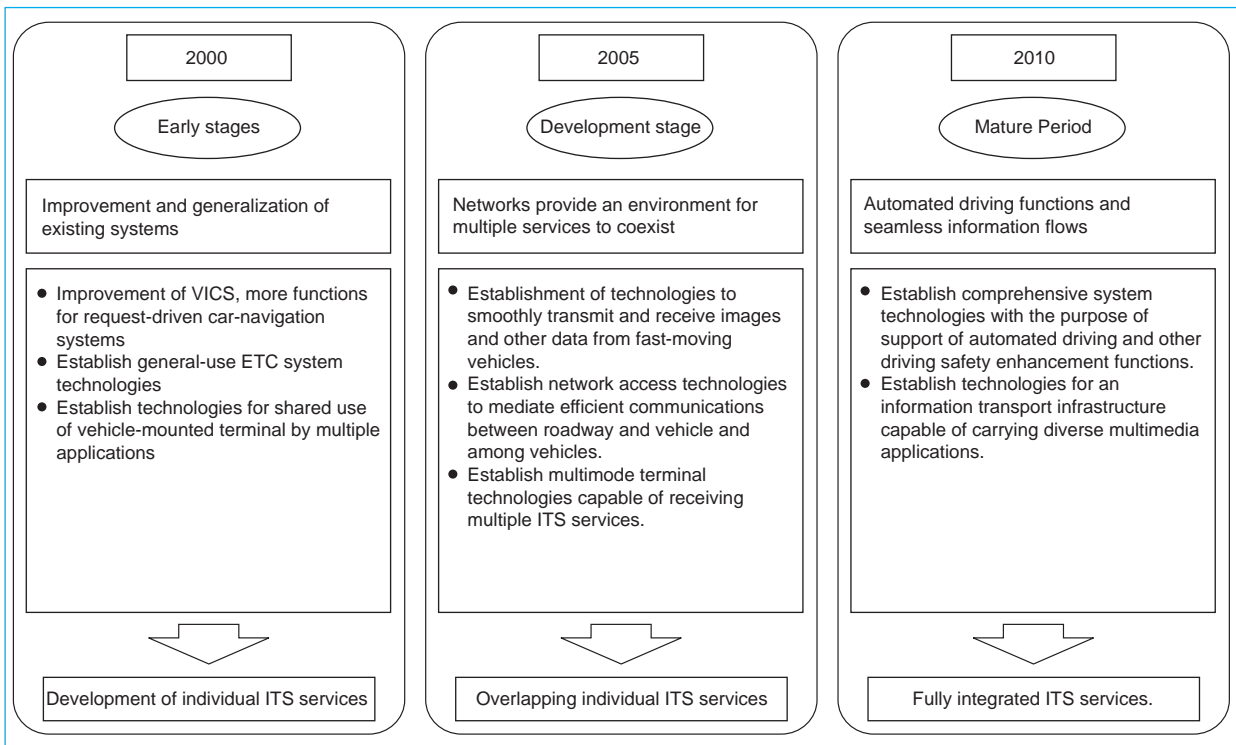

(Source: "Report of the ITS Information and Communication System Committee")

Fig. 4 Approximate development timescale for ITS information and communication systems.

cations will create business chances in the new ITS services market.

The ITS support market is expected to grow to 60 trillion yen by 2015 (Fig. 5.)

The ITS services market is expected to show a growth spurt in 2003, doubling every five years, reaching 65% of the entire ITS market by 2015.

Car navigation systems will eventually acquire powerful personal computer and Internet access functions, that could include an ETC transceiver.

Some 42 million cars are anticipated to fitted with car navigation systems by the year 2015. ITS will likely grow into a leading industry of the 21st century with concomitant contribution to employment: 330,000 new jobs by 2005, 1,070,000 jobs by 2015.

ITS TECHNICAL DEVELOPMENT ISSUES. Table 3 lists technical issues to be addressed in implementing ITS communications.

**Industry Assessment**

In the publication, "Investigation of roadway traffic issues in an information-Intensive Soci-

ety" with subtitle "Traffic in a Multimedia Society" The Planning and Adjustment Office of the National Land Agency has defined "information intensive" society as follows:

A society using advanced networking and telecommunications technologies to enable any individual to communicate any time with any remote or mobile location, to transmit, exchange or process needed information, and a society in which information drives the management of social infrastructure.

The report also listed five keywords suggesting that traffic flow and traffic management would be one of the distinguishing characteristics of an information-intensive society. The keywords are: remote, mobile, 24hrs a day/7 days a week service, personal availability and management (Fig. 6.)

ITS promises not only to resolve traffic problems but also to form the infrastructure for an information-intensive society that carries with it the potential to transform our concepts of transport (Fig. 7.)

ITS forms part of the social infrastructure and it is important that it ultimately merge

Table 3 Key Technologies for ITS Information and Communication Systems

Category	Subcategory	Technology
Systems		Wireless agents Quality of service control Security, authentication, encryption High-accuracy position detection and tracking Information conversion
Information	Multimedia authoring and production	Optimum data analysis Digital maps Traffic prediction
	Reliability	Highly reliable analysis/control Network maintenance support
Networks	Integrated optical and wireless	Bidirectional optical to wireless conversion devices Configuration of multiapplication base stations
	Wireless communication	Roadway-to-vehicle and intervehicle communications Configuring multivehicle bells*for tandem driving High-efficiency wireless access (high-reliability connection and transfer) Dynamic channel allocation High-speed handover Dynamic wireless zone control Dynamic range control Vehicle sensors
	Wired networks	Multicasting pathways High-speed routing Internetworking connection and control High-speed mobile address management
Advanced terminals	User interaction	Advanced user interfaces Voice recognition
	Vehicle-mount terminals	Multimode terminals Compact and highly integrated components Display devices
	Vehicle networks	Advanced vehicle LANs

(Source: "Report of the ITS Information and Communication System Committee")

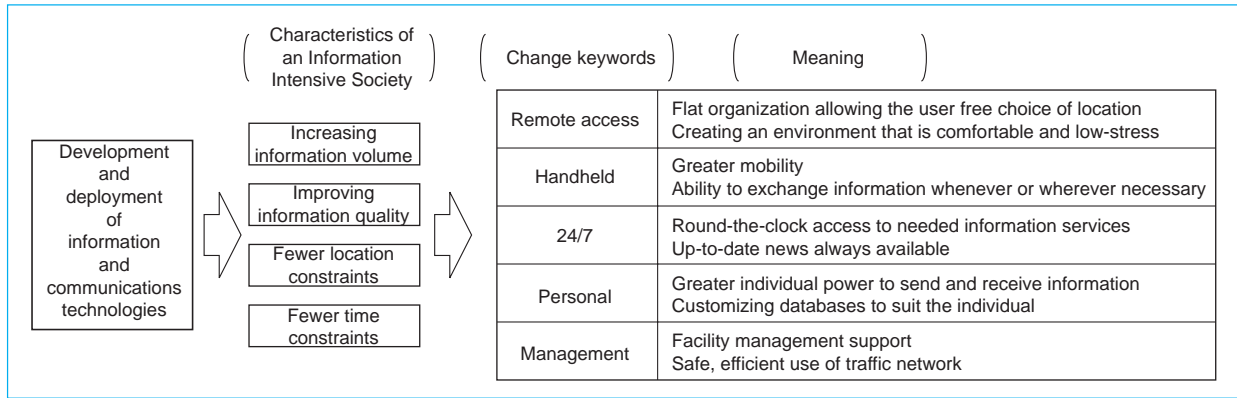

(Source: "Transport in a Multimedia Society")

Fig. 6 The phases of an information-intensive society.

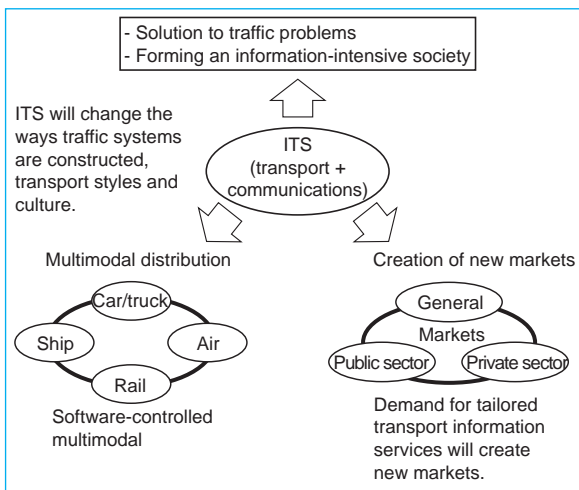

(Source: "Intelligent Transport Systems")

Fig. 7 How ITS will change transport concepts.

seamlessly with an information-intensive society. Development will start with infrastructure business, which will establish the way for growth in higher level communication services and information providers.

Information-intensive society will be a mobile multimedia society allowing anyone anywhere to access any information from any place at any time. People will be able to receive ITS services in their cars, in homes and offices and even while walking. We will need new ways of associating and combining information and some sort of universal information terminal.

Fig. 8 shows images of how an ITS system would be used in an information-intensive society. Fig. 9 shows an ITS application example using ETC technology.

### Mitsubishi Electric's ITS Strategy

The company is developing business in a sector

we refer to as computer, communication and visual (CCV) solutions, as shown in Fig. 10.

ITS builds on a foundation of infrastructure, communication, vehicle, sensing and user interface technologies. Mitsubishi Electric has all these capabilities, giving the company inherent strengths that can be leveraged for progress in its ITS business.

High-accuracy high-reliability pinpoint technologies are needed for identifying and controlling vehicles. The company has developed applicable technologies in space and defense projects that it will apply in ITS.

Fig. 11 shows ITS related business fields divided into four domains. Infrastructure is the first domain that we will develop. Platform business and information provider businesses will follow, finally we will see a shift of emphasis toward information and communications services.

### ITS Development at Mitsubishi Electric

**ORGANIZATION.** A team of exceptional business promotion executives drawn from the product divisions will form a working level group to draft guidelines and propose policy. In addition project committees will meet regularly to focus on ETC, AHS, distribution and other individual ITS projects, see Fig. 12.

**ACTIVITIES.** We will take up the company's various ITS projects in the other articles of this issue.

"Trends and Developments in ITS Major Projects" covers VICS, ETC and AHS and a proprietary distribution system currently under development.

"International Standardization Relating to ITS Platform Trends" describes Japan's contribution to international standards for ITS, various nations' work on system architectures, and



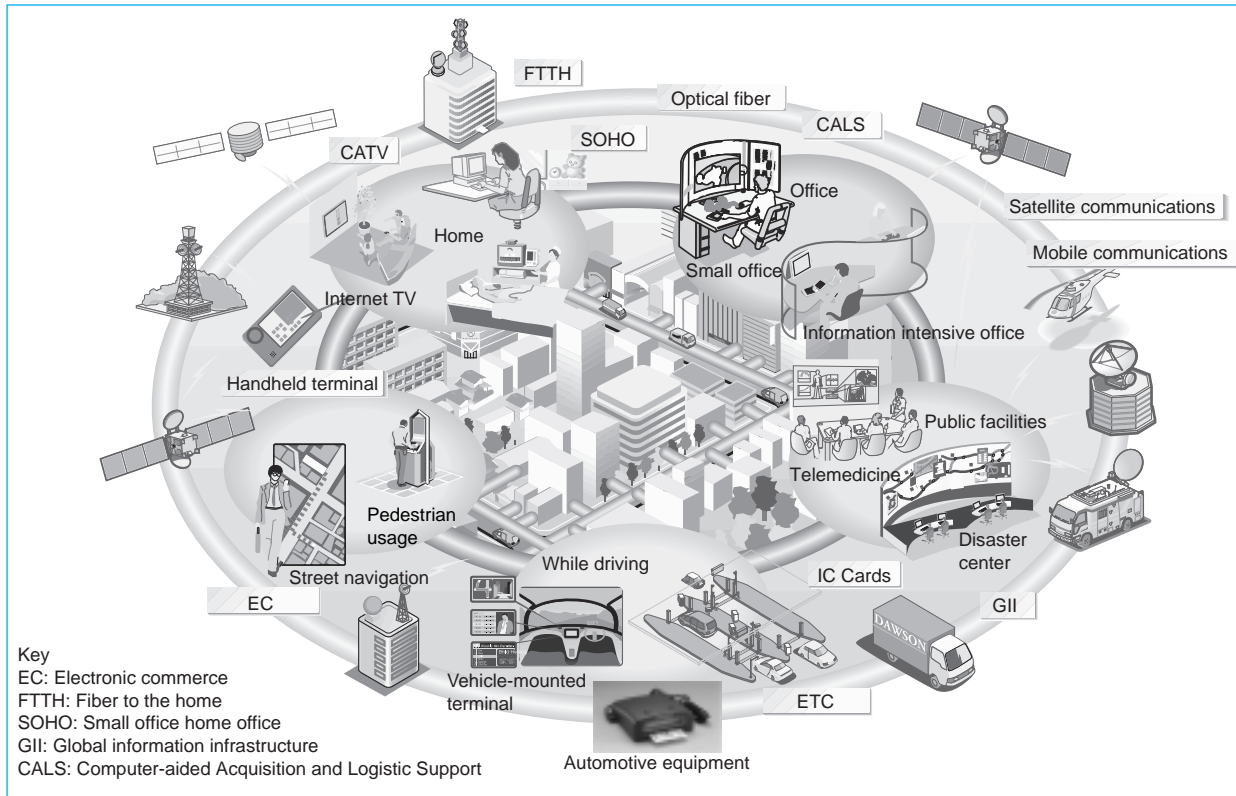

Fig. 8 Images of ITS services in an information-intensive society.

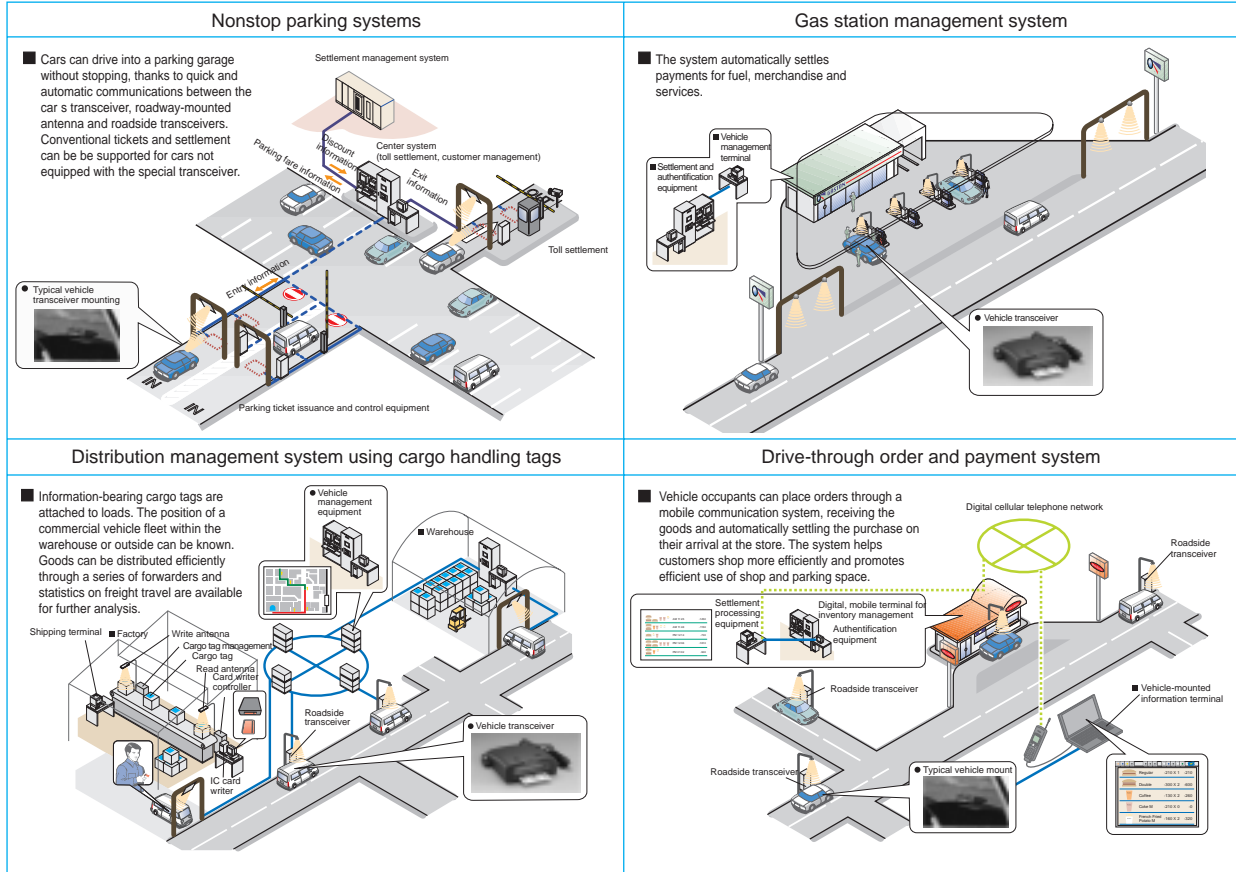

Fig. 9 ETC applications of ITS technologies.

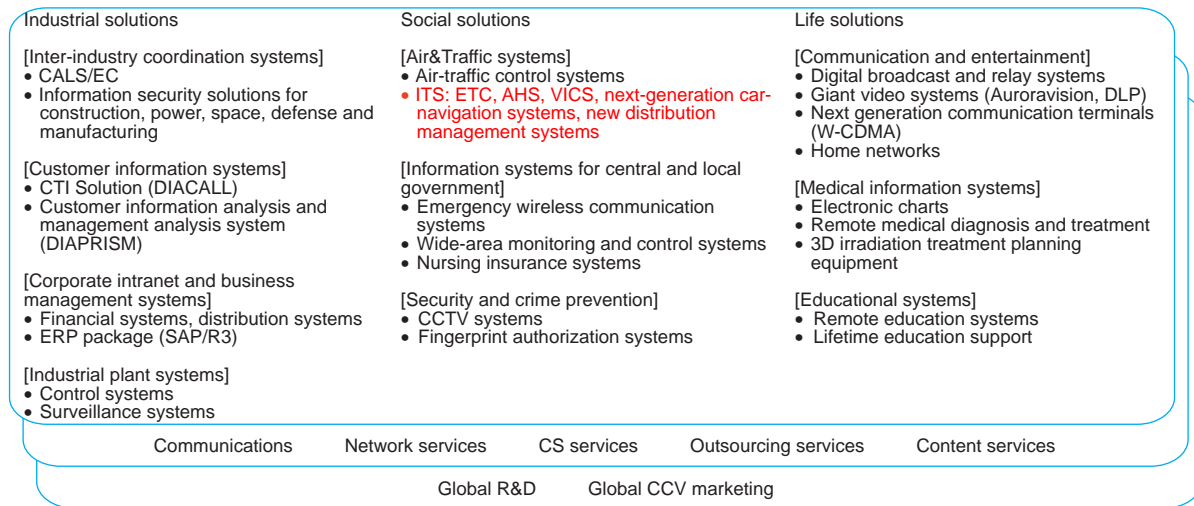
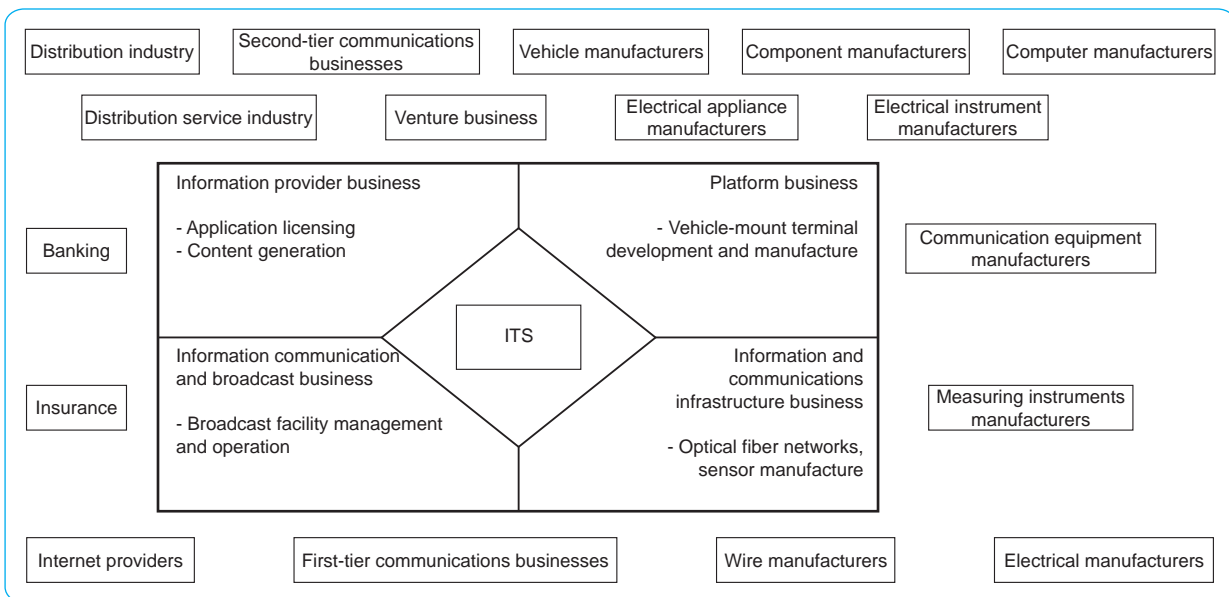

Fig. 10 Mitsubishi Electric's CCV solutions



(Source: "Intelligent Transport Systems")

Fig. 11 ITS business domains.

policymaking in Japan. The report on standardization activities covers work on protocols, data dictionaries and message sets.

"ITS Related Topics" introduces ITS simulation systems, composite sensor systems and compact scanning laser radar for vehicles.

**Conclusions**

In the three years since our first special issue on ITS (December 1996) ITS has been selected as a central component of the government's economic stimulus policy. ITS business has grown active with sales of VICS-capable car navigation systems and the inauguration of ETC services at the end of 1999. In Japanese newspapers we

have seen extended articles on ITS. ITS appears to have passed its teething stages and the pace of development is quickening.

ITS is the business model for information and communications in the 21st century, and will be a litmus test for survival in the changing economic climate of the new century. The structure of industry is changing in fundamental ways, a genuine paradigm shift.

We expect to see closer ties with general contractors, automotive manufacturers and a relaxed regulatory climate in which Mitsubishi Electric may one day manufacture electric vehicles. The current conventional wisdom is often a poor guide to the future but we can see a

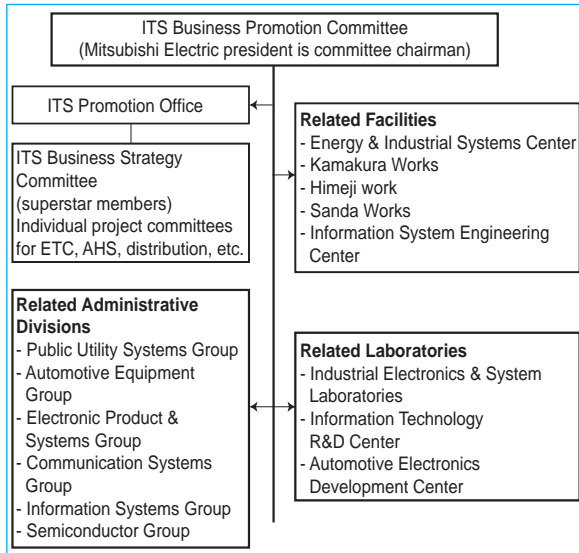

Fig. 12 Promotion of ITS at Mitsubishi Electric.

postindustrial shift from manufacturing toward information industry, software and services.

Looking forward, the company is taking ITS as a business model for the 21st century. We believe it will be necessary to reinvent ourselves to adapt and thrive. We are approaching a choice of whether to focus on hardware or to diversify into software and information services.

Mitsubishi Electric received contracts for Japan's first ETC system along with Fujitsu and JVC. We expect that the MISTY cryptographic encoding will be adopted for the security system. The company expects to continue expanding its ITS business as these technologies are deployed more widely. □

# Car-Navigation Systems

by Kazuhiro Yokouchi, Hiroaki Ideno and Masako Ota\*

Japanese electronic manufacturers have led the industry in car-navigation technology and the Japanese domestic market for car-navigation systems is the most developed. Four millions car-navigation systems had been installed by 1998, including a million with VICS receivers providing information on road and traffic conditions. The Electronic Industries Association of Japan predicts a near doubling of sales, growing from 1.3 million units in 1999 to 2.4 million in 2003.

Car-navigation systems promise to ease traffic congestion and improve the driving environment. They are the most advanced and widely implemented of the nine intelligent transport system (ITS) technology areas that Japan's Ministry of Trade and Industry has designated for development. A parallel trend is the rapid movement to introduce information and multimedia technologies to cars, and car-navigation systems offer a convenient platform to deliver a wider range of information services.

Mitsubishi Electric is responsible for numerous innovations in the field. In this article, we introduce some of these developments and discuss other advances and trends.

## Description

Fig. 1 shows a typical system configuration. Navigation-related functions are shown with solid lines; additional information functions with broken lines. Absolute position data from the GPS receiver is combined with speed signals integrated over time and direction information from a vibratory gyroscope to match the current vehicle position on digital roadmaps using data from prerecorded media. The system plans routes to the driver's destination and displays the routes on the map. Newer systems for Japan usually include a receiver for VICS broadcasts, adding the status of congested roads to the map display. The map scrolls as the car moves; a synthesized voice directs the driver to turn right or left as needed to reach the destination.

The industry is moving toward supplementing basic navigation with an audio system, TV tuner, air-conditioner controls, electronic toll collection transceiver and cell phone. An integrated display with multiple windows and display over-

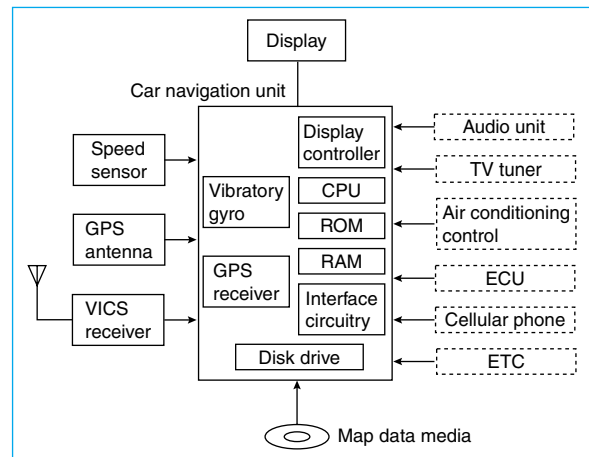

Fig. 1 Functional blocks of car-navigation systems.

lay capabilities is needed to provide ready access to these information and control functions.

## Developments at Mitsubishi Electric

Our first car-navigation project began in 1977 with an electronic compass and a dead-reckoning navigation system. In 1985 we demonstrated a car-navigation system capable of receiving GPS signals available from US military satellites. GPS functions have been an integral part of our commercial products since 1990 when we delivered the world's first GPS capable systems to Japanese automakers.

Mitsubishi Electric introduced an original route-guidance system in 1995. A VICS receiver and ancillary functions were introduced the next year. In 1997, the company launched a new system with an innovative on-dashboard display in the European and Japanese markets. Systems for the United States debuted the following year. In 1999, the company introduced the industry's first DVD-based system, using the large-capacity media to add audio and video entertainment capabilities.

We will now look at some of the key technical innovations:

**POSITION DETECTION ACCURACY.** Detecting the vehicle's current position is the first and most important task of a car-navigation system. Dis-

\*Kazuhiro Yokouchi, Hiroaki Ideno and Masako Ota are with the Sanda Works.

tance and direction-of-travel data are combined to identify the current vehicle position. Error in this determination can be corrected by a map-matching technique, or by using the absolute position determination available from a GPS receiver.

**ROUTE CALCULATION.** Routes can be determined using a mathematical algorithm to find the shortest paths between points on a graph consisting of nodes and links, however a flat graphical representation of a map would require an impracticably large database and involve an enormous number of calculations. We simplified the problem by adopting a two-level map representation in which lower the layer has greater detail. This approach simplifies the problem, reducing both the amount of data required to represent the relevant parts of the road system and the computational cost of finding the shortest path.

Mitsubishi Electric's 1995 car-navigation system implemented this approach using a 32-bit RISC processor, achieving the fastest route-calculating performance in the industry. We used the A\* method to calculate the major routes traversed, then used the Dijkstra Method to perform a search in all directions from the current position (Fig. 2).

A new area-to-area search algorithm in the 1997 Model CU-5800 aftermarket car-navigation system achieved the fastest performance in a commercial CD-ROM based system: 9.9s to calculate a route between points in Tokyo and Osaka. The system's map database contains predetermined route data that reduces the volume of memories by recognizing that the same major traffic arteries will be used for the vast majority of starting point and destination pairs (Fig. 3). With the help of this simpler approach, the problem of finding a path from the current vehicle position to the destination can now be solved by traversing a tree graph with the current position as the trunk. Used in 1999 model DVD-based systems, the technique halves the time required to calculate routes between points in Tokyo and Osaka to 5.5s.

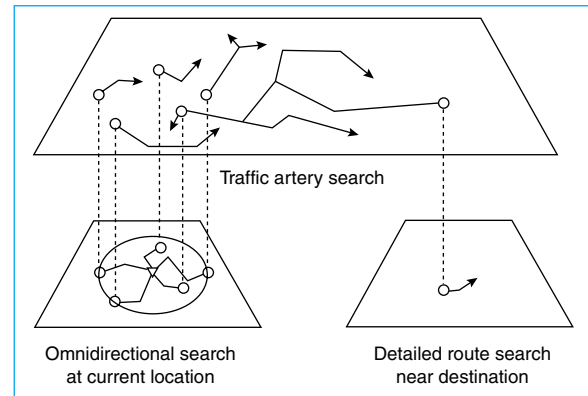

Fig. 2 Route search using a two-level map database.



Fig. 3 Arteries for current area display (Osaka)

**ROUTE GUIDANCE.** Route guidance is another essential function of car-navigation systems—the process of communicating the selected route to the driver as the journey advances. The user interface is especially important since excessive demands on driver attention can adversely impact safety.

Designing the user interface to communicate roadway details to the driver at a glance requires strict attention to the information content and perception process.

Our research on perception led to choice of a sketch-map presentation. Fig. 4 shows a sketch-map of an intersection. Cross street names are shown as road signs preceding the intersection.



Fig. 4 Intersection sketch-map.

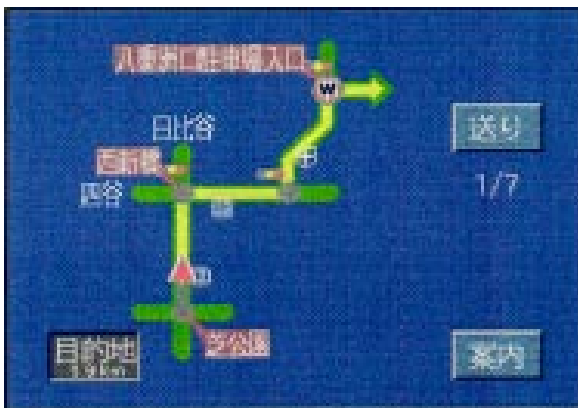

Fig. 5 Route sketch-map.



Fig. 6 Intersection sketch-map with 3D perspective.

Fig. 5 shows a road sketch-map with labels showing turns and milestones. It is modeled after a hand-drawn map. Both types of map are generated in realtime from data contained in the CD-ROM. The display-generation software is implemented in a rule-based predicate logic language. The guide maps are generated by synthesizing various geographical attributes into an easily digestible format.

Fig. 6 shows the sketch-map method applied to generate intersection maps with a 3D perspective. This capability has been available to Japanese automakers since 1998. This presentation, suggesting movement through the landscape, shows each lane—indicating its direction (straight through or turning) and destination—along with intersection names and other landmarks.

TRAFFIC CONDITIONS. Drivers need to know about the flow of traffic around them. Data on traffic conditions has been broadcast to urban drivers in Japan since 1995 under the VICS system.

VICS delivers data via three transmission mechanisms: FM multiplex broadcasting to distribute data over a wide area, and roadside radio and optical beacons to communicate local hazard and warning information.

VICS can inform drivers of traffic congestion, closed lanes and reduced speed limits due to construction work or road hazards, travel times and parking availability. VICS service areas are being expanded. Three types of display formats are supported: text-only display, simple graphics, and superimposed over the navigation maps. Fig. 7 shows an example of this last type.

The company has been involved in early planning and testing of VICS technology, and can now deliver VICS-capable systems to car manufacturers supporting all display formats. Top-end systems superimpose VICS data over the guide maps and are capable of dynamically updating the optimal route in response to traffic conditions.

The EU has launched Radio Data System Traffic Message Channel (RDS-TMC) services that resemble Japan's FM multiplex VICS broadcasts.



Fig. 7 VICS data displayed over route map.

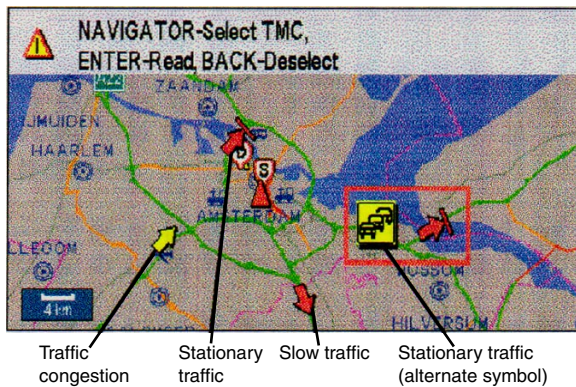

Fig. 8 RDS-TMC display.

In 1997, we began delivering car-navigation systems for Europe with RDS-TMC receivers. In 1998, our European models incorporated dynamic route updating based on congestion and lane-restriction data delivered by RDS-TMC. Fig. 8 shows RDS-TMC data superimposed on a navigation map.

**COMMUNICATIONS.** Interactive communication capabilities are consistent with the information-intensive nature of car-navigation systems. Mitsubishi Electric has developed functions to allow cars fitted with navigation systems to exchange position information. The company has also developed fleet-management systems that allow an office to monitor movements of a vehicle fleet.

The company is also developing products that enable a car to communicate with a specialized information system or the Internet over telephone and cellular networks. Many kinds of information services and content are being studied. Vigorous development is underway in overseas markets and Mitsubishi Electric plans to support new information and communication models on its navigation system platform.

**SAFETY ENHANCEMENTS.** Navigation-related data can contribute to improved safety. In 1995, we launched traction-control technology that uses curvature data to set a ceiling on the vehicle's speed through the turn. We have also introduced an audible warning system that alerts the driver to approaching curves or other hazards. Other manufacturers are offering systems that control the vehicle's automatic transmission.

Mitsubishi Electric conducts R&D on sensors and control units for safety purposes at its Himeji Works. Car-navigation systems can incorporate these functions and contribute to safer transit.

### Overseas Markets

Delays in assembling map databases and high product pricing has slowed introduction of car-navigation systems overseas. In 1998, sales reached 160,000 systems in Europe and 100,000 in the United States. Growth is expected to accelerate. In 1997, Mitsubishi Electric became the first company to offer automakers car-navigation systems for the European market with integrated RDS-TMC functions.

Fig. 9 shows an on-dashboard car-navigation system for the US and European markets. A CD-ROM changer is used to support multiple map data discs. For Europe, RDS-TMC support for European models enables the system to avoid congested and blocked roads. Audible announcements can be made in any of eight languages. Signals are delivered from the vehicle's ECU to the navigation system over the CAN bus.

Fig. 10 shows the display of a car-navigation system with turn-by-turn guidance that was launched on the European market in 1998. The system's multipurpose display serves as an interface to the car audio system, air conditioning



Fig. 9 Car-navigation display for European market.



Fig. 10 A car-navigation system for Europe with a multipurpose information display.

status, fuel economy, remaining travel distance on the current tank and outside air temperature.

**Future Trends**

Support for many of the additional functions in

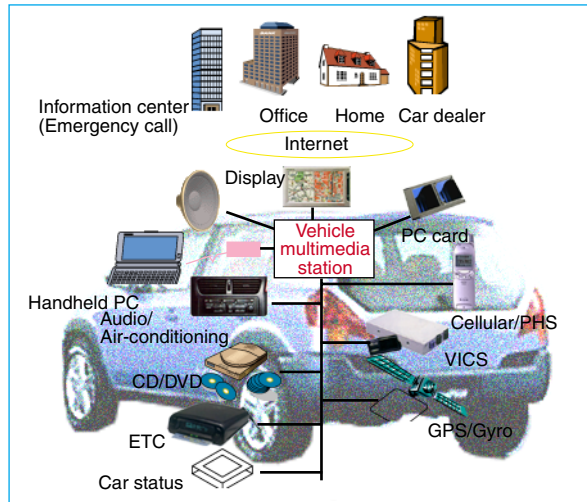

Fig. 11 Vehicle information station.

the car-navigation system shown in Fig. 1 has been realized, while processing performance now compares favorably with today's personal computers. Car-navigation systems are well on their way to becoming car-information stations.

Fig. 11 illustrates future possibilities of such car-information stations. Nearly all of these capabilities are ready for commercial debut. Multimedia capabilities are projected to utilize digital broadcasting and high-capacity DVD media. Systems will be linked via cellular networks to special-purpose information centers or the Internet. The same multipurpose displays are being adapted for information and entertainment use by rear seat passengers.

Car-navigation systems are emerging as a primary platform to meet demand for vehicle-based multimedia information and entertainment services. The mobile nature and limited interior dimensions place special constraints on system design, while offering the potential for safer, simpler and more entertaining travel. □



# Electronic Toll-Collection Systems

by Hiromitsu Kato and Yuji Hirooka\*

Electronic Toll-Collecting (ETC) systems offer a convenient, cashless toll payment system that promises to eliminate traffic stoppage at toll plazas—a principal cause of traffic congestion. The system will also reduce toll-plaza operating costs. Toward these benefits, the Ministry of Construction and four expressway public corporations have been working to introduce ETC technology. The group initiated joint ETC research in 1995 and, five years later, the first practical ETC system has opened in the Chiba prefectural area including the East Kanto Expressway.

Mitsubishi Electric has developed the basic technologies required for these systems. The company participated in the initial joint research, and conducted tests of the various components of the system followed up by extensive testing in actual toll-plaza facilities. The company has developed a roadside-to-vehicle wire-

less communication system, an encryption-based security model and all the equipment required for ETC, ultimately applying these technologies as complete ETC systems for the East Kanto Expressway and other roads in Chiba Prefecture. This article introduces ETC systems. Fig. 1 shows the general configuration of such a system.

## Goals

Goals of Japan's ETC development program include: establishing nationwide standards, fast and accurate toll collection, security and privacy protection and future expandability.

Benefits of introducing ETC systems include reducing traffic congestion, increasing traffic safety, convenient cashless payment, and reduced toll-plaza operating costs.

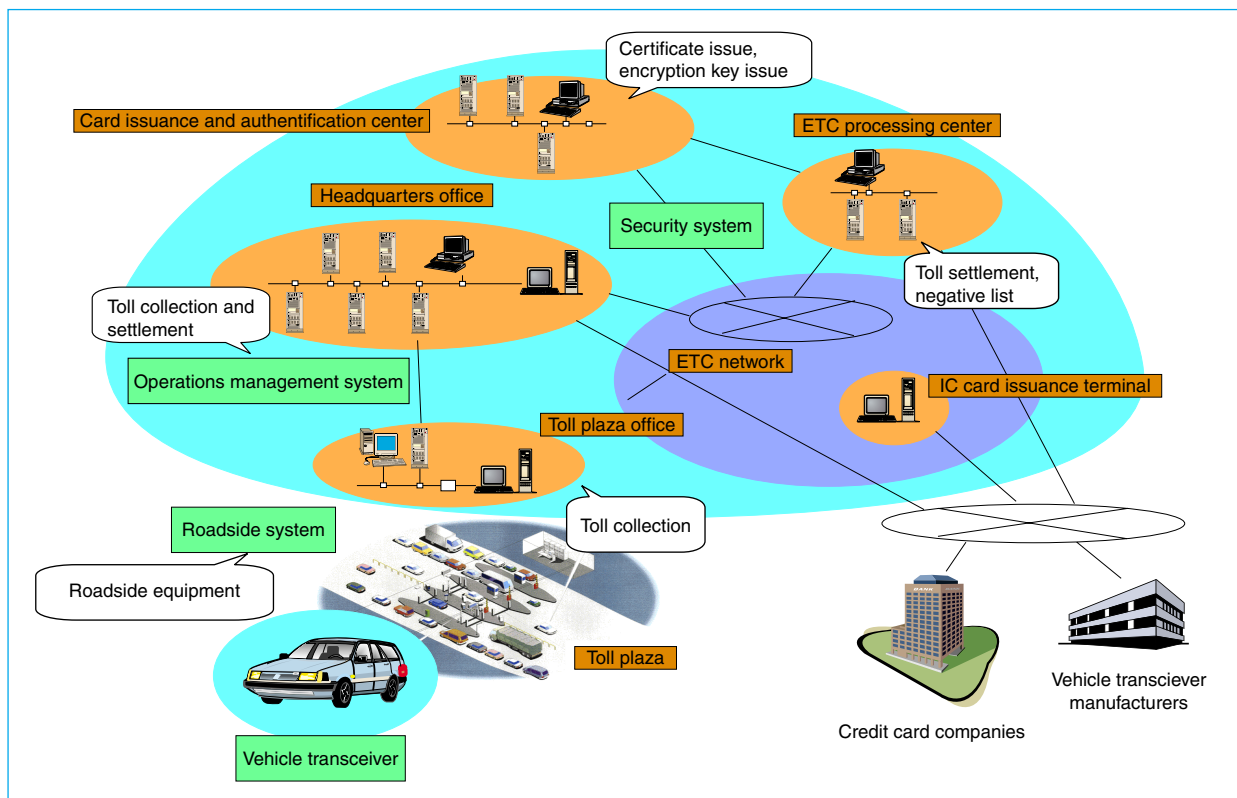

Fig. 1 Electronic toll collection system.

\*Hiromitsu Kato is with the Kamakura Works and Yuji Hirooka is with the Public-Use Systems Marketing Division.

**System Configuration**

ETC systems have to support various toll systems, including both open and closed systems. In open systems, the toll fee is paid at an entry toll plaza. In closed systems, the toll fee is paid at an exit toll plaza with the charge based on the distance driven between the entry plaza and the exit plaza. Fig. 2 illustrates the configuration of a closed system.

The operations management system collects

and processes toll-collection data. The system is installed at the toll-plaza office or expressway company headquarters office. A central toll-settlement system is being planned for use by ETC systems nationwide. When a car passes through the toll plaza, the toll server for that lane transfers data for the transaction to a server in the toll-plaza office. The server is linked to a host at the central office.

The security model for ETC systems is real-

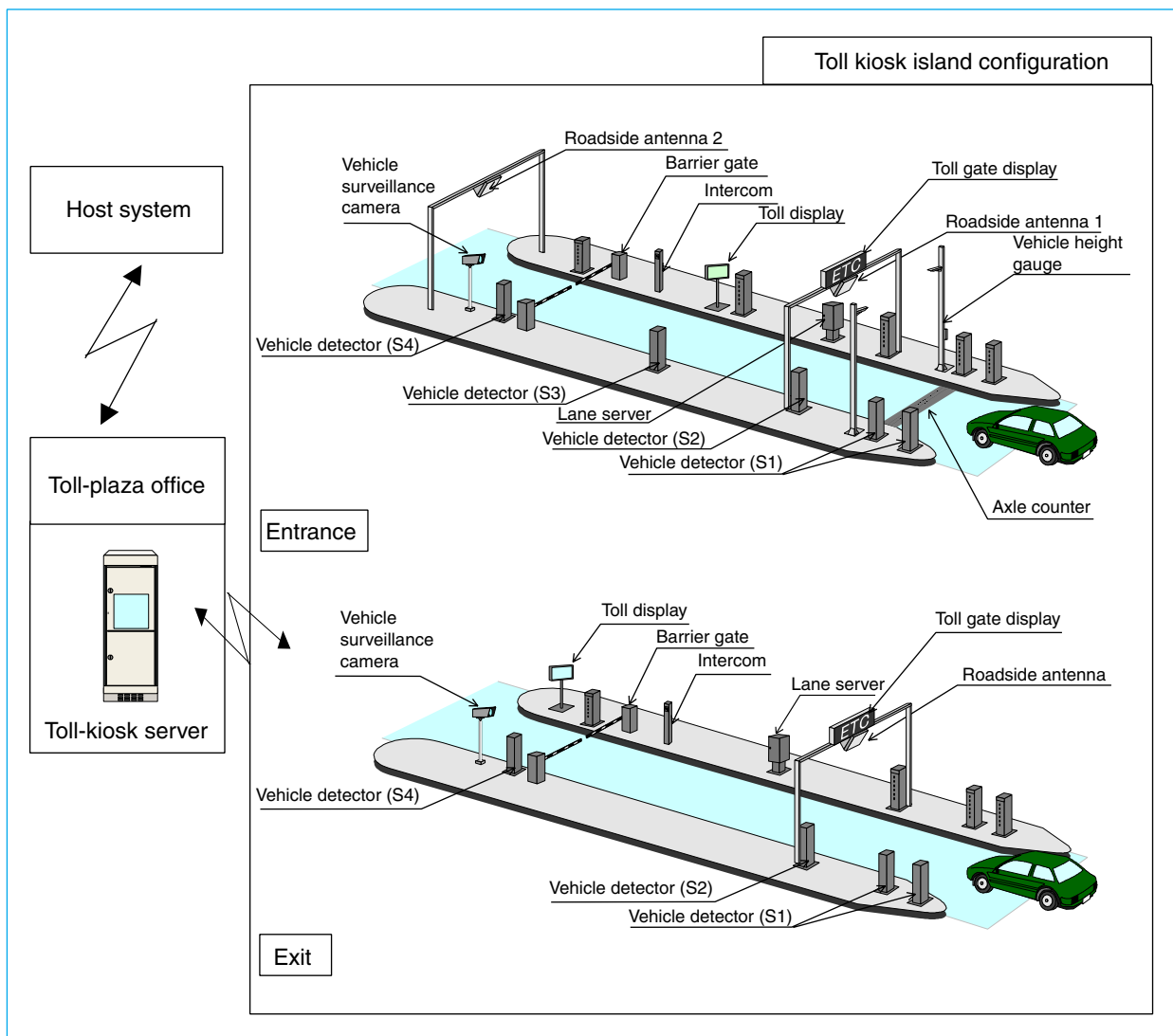

Fig. 2 Example of system configuration.

ized by an IC-card issuing and authentication authority, and terminals that issue cards. Network-level security protects the entire system. Roadside-to-vehicle communication is encrypted.

Roadside equipment installed at toll islands for ETC lanes at the toll plaza typically includes vehicle detectors, a toll display, a toll-gate display, a roadside antenna, a barrier gate, a lane server and a CCTV camera. The system must allow traffic to flow smoothly while halting irregular vehicles such as those without IC cards or transceivers. Traffic-directing displays may be installed on the roadway leading up to the toll plaza to facilitate smooth vehicle flow.

The roadside equipment communicates with the vehicle transceiver to automatically collect the toll. The Japanese ETC standard specifies that vehicle transceivers using active technology should incorporate an IC card system.

#### Roadside-to-Vehicle Communications

Dedicated Short-Range Communications (DSRC) technologies are used to implement toll-collection functions that can successfully process a transaction in the brief interval it takes for a vehicle moving at speed to pass through a confined communication area. The system must recognize each vehicle, apply the appropriate toll schedule, and complete an electronic payment

transaction without interference from wireless equipment in adjoining lanes. System acceptance requires that communication errors shall be less than one in one million. Table 1 lists the wireless communication specifications of the system.

ROADSIDE WIRELESS EQUIPMENT. Fig. 3 shows the appearance of the roadside antenna of the wireless communication equipment. A shaped beam antenna with uniform coverage of the target area and low sidelobe levels communicates



Fig. 3 Antenna of roadside equipment.

Table 1 Specifications of Wireless System for Road-to-Vehicle Communications

Frequencies	Two pairs in the 5.8GHz band
Bandwidth	8MHz max.
Channel spacing	40MHz
Transmitter output	10mW
Communication system	Active type with slotted Aloha
Communications coverage area	1m above roadway surface, 4m in the direction of vehicle travel, 3m across direction of road
Maximum vehicle speed	80kph
Data transmission rate	1.024Mbps
Modulation method	Amplitude shift keying
Modulation index	Between 0.75 and 1
Encoding method	Manchester encoding
Bit error rate	Less than $10^{-5}$
Communications error rate	Less than $10^{-6}$ (per single vehicle and single toll plaza)

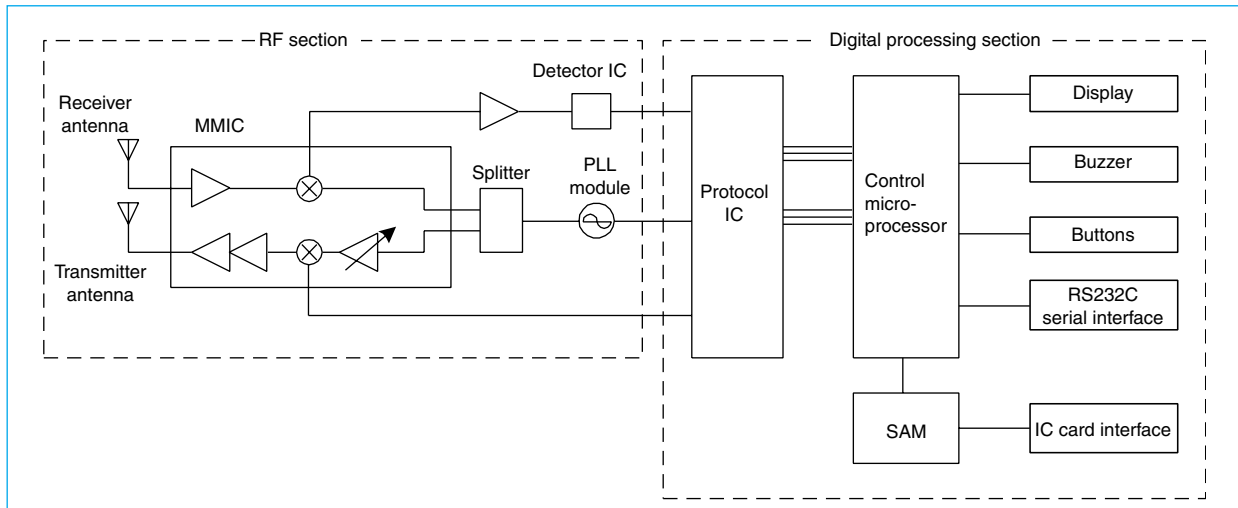

Fig. 4 Block diagram of vehicle transceiver.

reliably with the target vehicle while avoiding communications with leading, trailing or adjacent vehicles. The combination of planar transceiver antenna with a coplanar feed system which is installed upstream of the toll plaza is compact and inexpensive. The approach antenna, which must give uniform coverage of a wider communication area, uses cosecant-squared beam shaping.

**MODEM.** Communications between roadside and vehicle take place over a confined area as the car passes at speed, providing only a brief window for the exchange of data. The communications transaction must therefore be completed in a short burst. The preamble that synchronizes the negotiation occupies just 16 bits.

The modem we developed to accomplish this task uses discrete Fourier transforms for fast acquisition and stable operation of clock recovery in order to suppress cycle slippage. In addition, the modem compensates for waveform distortion of the received signal caused by analog circuits. These modem capabilities and the design of the clock sync preamble give the system a bit error rate of less than  $10^{-5}$ .

**VEHICLE TRANSCEIVER.** The vehicle transceiver must function as a friendly man-machine inter-

face in addition to retaining its wireless communication functions over a wide temperature range. Mitsubishi Electric has developed a compact ETC vehicle transceiver that meets these requirements. Fig. 4 shows a block diagram and Fig. 5 the unit's appearance. The company has developed a microwave monolithic IC (MMIC) for the radio frequency circuits, a protocol IC to handle digital processing, and an electroluminescent panel capable of displaying icons and text characters. Table 2 lists the unit's performance data.



Fig. 5 Vehicle transceiver.

Table 2 Specifications of Vehicle Transceiver Unit

Power supply	12VDC (supplied by car battery)
Operating temperature range	-30 ~ +85°C
Storage temperature range	-40 ~ +105°C
Icon displays	"ETC" (communications underway), "CARD" (IC card inserted)
Other display items	Go/stop guide, toll amount, expiry date, toll transaction history
Alarm warnings	Self-test at power on, successful/failed communications, IC card missing
Installation site	Dashboard
Optional functions	Voice guidance unit, printer

The MMIC is a GaAs device that integrates a modulator, amplifiers and frequency converters. This device gives consistently high performance while at the same time its size is only one twentieth that of a conventional circuit. Field-effect transistors with self-aligned gate (SAGFETs) used at 2GHz have been modified to operate in the 5.8GHz band at little additional cost.

ICs have been developed for the data-link layer: the modem, which uses Manchester encoding and non-return-zero conversion, and the clock regeneration control and PLL module control functions.

The easy-to-read electroluminescent panel displays six 5 x 7 dot characters and two icons.

Options include a voice-guidance unit that can be connected to the transceiver's serial port. The transceiver can also be connected to a car

navigation system, allowing toll display on the navigation screen.

**Auxiliary Functions**

**POSITION DETECTION.** Vehicle position detection capabilities make possible free-flow toll plaza systems. In these plazas, ETC transactions can be conducted without dividing the lanes, so that cars can overtake or be between lanes while passing through. Mitsubishi Electric has used the direction of arrival (DOA) method to determine vehicle position from signals emitted by the vehicle transceiver. The vehicle position

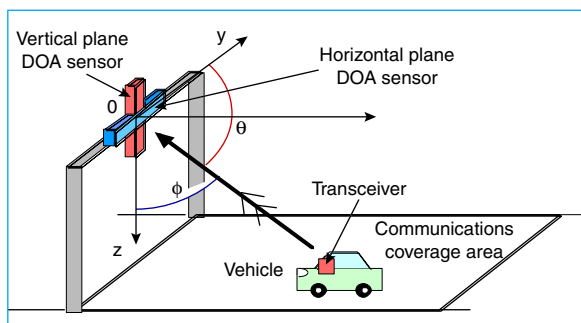

Fig. 6 Vehicle position detection by direction-of-arrival (DOA) sensor.

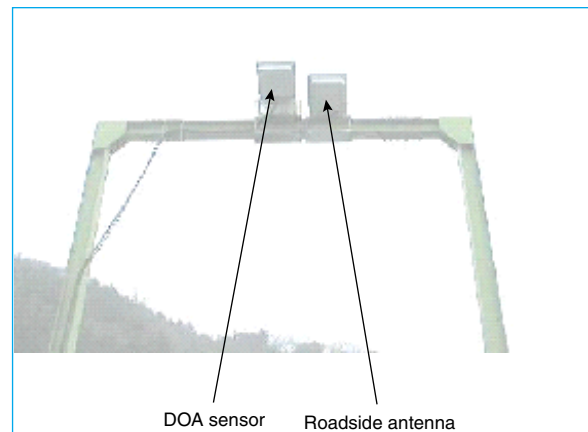

Fig. 7 Installation example of DOA position detection system.

detector is designed to reside with the RF circuitry in the roadside wireless equipment. Vehicle position can be detected within 0.5m in the direction of vehicle travel, and within 0.5m across the lanes. Fig. 6 shows vehicle position detection using the DOA technique. Fig. 7 shows a typical installation of the roadside equipment. The position-finding capabilities can be used in conventional separate-lane toll plazas as well.

**IEEE1394 INTERFACE.** Data-transfer demands on roadside terminal equipment are likely to increase. The IEEE1394 interface offers sufficient data-transmission capabilities for future high-speed transfers while also supporting general-purpose packet communications. The company has developed a 400Mbps IEEE1394 interface.

ETC is part of the first wave of intelligent transportation systems to be put into practical use, and Mitsubishi Electric has been developing all the basic technologies required for its implementation. The company is putting these experiences to use in developing advanced-cruise-assist highway systems and free-flow ETC systems. It has also been developing non-stop parking garages, logistic management systems, and roadway information service systems. Vehicle transceivers will be developed to meet the range of DSRC applications at low cost.□

# Advanced Cruise-Assist Highway Systems

by Tetsuo Miyoshi and Akira Horiguchi\*

Advanced cruise-assist highway systems (AHSs) are being developed to reduce the demands of driving, improve travel safety and efficiency, and lower the environmental impact of driving. The AHS Research Association (AHSRA), established in September 1996 under the authorization of the Minister of Construction, is initiating development of AHS technology in the three areas of information delivery systems (AHS-i), driving assistance (AHS-c), and automatic driving (AHS-a), see Table 1.

Mitsubishi Electric has developed basic technologies and products, and has conducted systems development and consulting work for the AHS Research Association.

This report describes the AHS functions and configuration, the image-processing technologies for AHS implementations, and the information services potential of road-to-vehicle communication.

Table 1 AHS Stages and Services

Service name	Service content	Potential benefits
AHS-i (information)	Supplemental information about traffic, closures and hazards on the road ahead	Safety and ease of driving improvement
AHS-c (control)	Driving support services including limited actions to hold the vehicle within a lane; uses roadside infrastructure and vehicle-mounted sensors	Improved safety and ease of driving
AHS-a (automated cruise)	Automatic driving capabilities	Improved safety, ease of driving and vehicle operation efficiency

Finally we discuss the partition of functionality between roadside and vehicle-mounted equipment, and how it impacts implementation of the control functions of AHS-c and the automatic driving functions of AHS-a.

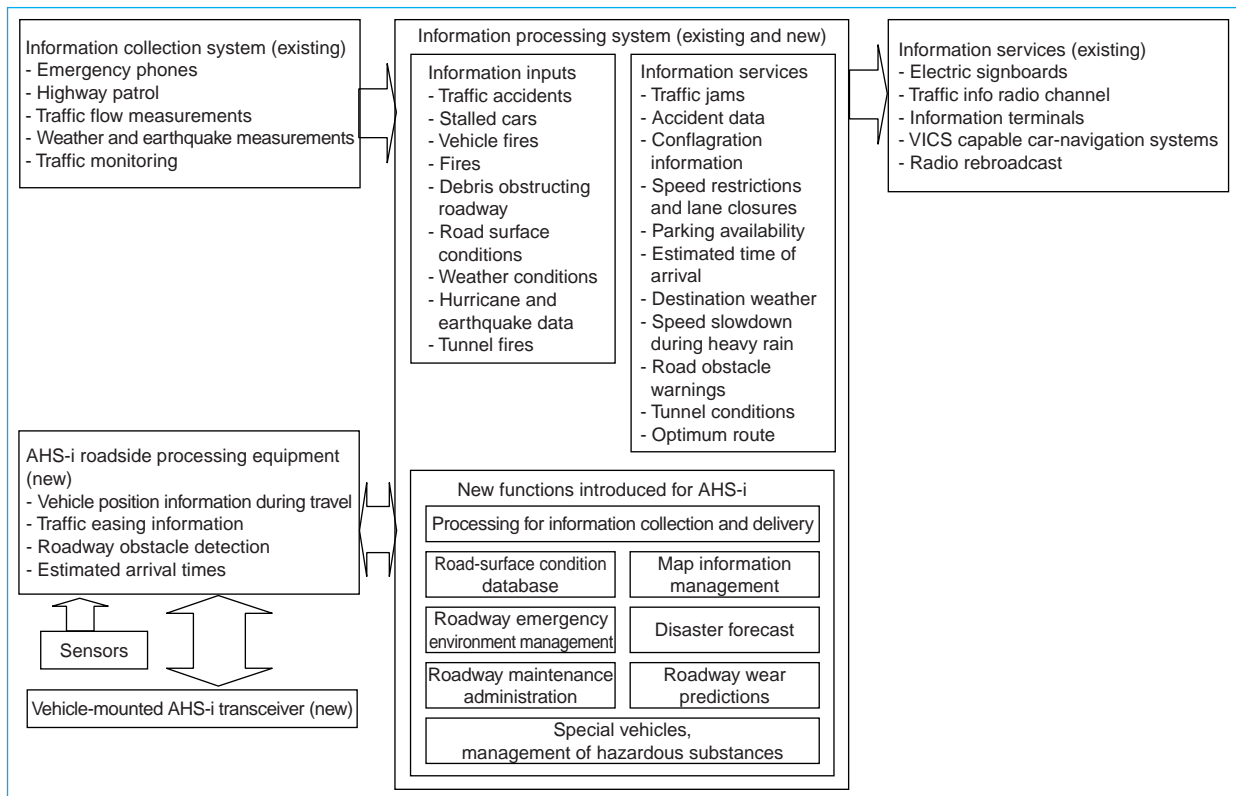

Fig. 1 Functions and configuration of a roadway management system supporting AHS-i.

\*Tetsuo Miyoshi is with Kamakura Works and Akira Horiguchi is with the Energy @ Industrial Systems Center.

### Functions and Configuration of Roadway Management System

The functions and configuration required for road-management systems to support AHS-i are shown in Fig. 1. Road-management systems will need the following functions so that AHS-i roadside equipment can process information, such as changing vehicle positions and the positions of traffic jams, road-surface conditions, road obstacles and estimated time to destination, and deliver this information to the roadway management authority to facilitate maintenance:

- AHS information collection and delivery functions
- Road shape database functions
- Map information management functions
- Functions for managing the road environment near accident sites
- Disaster warning functions
- Road maintenance planning support and disaster preparedness functions
- Functions for special vehicles such as emergency vehicles and vehicles loaded with hazardous substances

By adding these functions to the information processing system, the content of existing information delivery systems can be expanded and information can be delivered to new AHS-i capable vehicle transceivers.

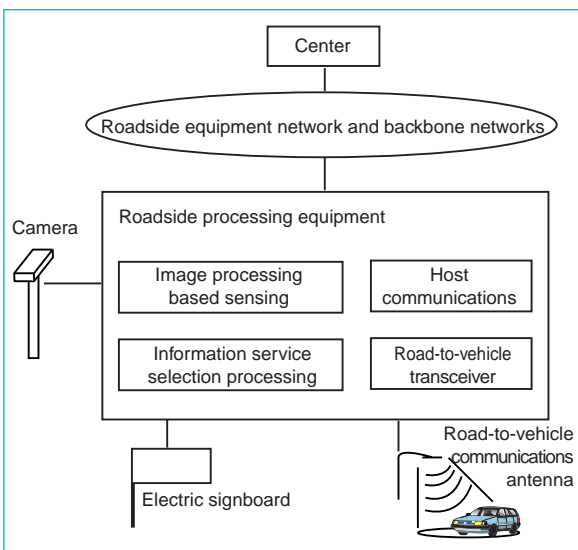

Fig. 2 Roadside processing system for AHS-i.

### AHS-i Roadside Processing Equipment

Implementing AHS-i will require functions capable of sensing vehicle positions and environments, including other vehicles, obstacles and road-surface conditions, functions for generating guidance from road-environment data, and road-to-vehicle communication and other roadside infrastructure. Information on weather conditions and road-lane configuration must also be taken into consideration.

**AHS-i ROADSIDE PROCESSING EQUIPMENT.** As shown in Fig. 2, this equipment consists of an image-processing subsystem that can observe traffic and detect obstacles on the road surface and a transceiver for communicating with vehicles. It may also include subsystems for selecting information services and for communicating with a higher-level host.

**IMAGE-PROCESSING SUBSYSTEM.** This subsystem will use image processing to detect road obstacles and other vehicles, and to observe traffic. Techniques will be needed to maintain performance at all times under varying weather conditions and sunlight illumination levels. Realtime measurements of vehicle position and speed and the position of roadway obstacles will also be required.

Mitsubishi Electric has developed a method to detect the presence of vehicles or objects on the roadway by identifying differences between vehicle and background and using them to extract the desired objects. This technology has been commercialized as high-speed image-processing equipment.

An image-processor board uses a high-speed digital signal processor (DSP) to deliver realtime processing capabilities. The algorithms are implemented in software, allowing future modification. The texture background difference method is used to implement a system that can analyze both visible and infrared images and is robust under weather effects and varying illumination and background patterns. The system can detect vehicles and road obstacles.

The functions required to implement image processing-based sensing functions of AHS-i include the following:



- Stopped and slow-moving vehicle detection
- Detection of high-speed and oncoming vehicles
- Detection of road obstacles
- Traffic jam detection
- Motorcycle, bicycle and pedestrian detection
- Detection of lane deviation and other unusual conditions

Mitsubishi Electric is implementing these functions aiming at round-the-clock capabilities under all-weather conditions (Table 2.)

**Road-to-Vehicle Communications**

Road-to-vehicle communications will enable bidirectional data exchange between AHS-i roadside systems and moving vehicles. Fig. 3 summarizes the system. The following technical issues need to be addressed.

Wireless service areas—typically several hundred meters along the roadway—will be configured as multiple zones. High-speed handover will

be necessary so that successive vehicles entering the service area can be recognized and passed off from zone to zone.

These requirements are significantly different from ETC or VICS services which have a spot coverage pattern.

The same high transmission quality must be maintained for all vehicles passing each wireless zone, some of which may be traveling at high speed. The system must be designed to resist fading and shadowing effects. The system must also maintain efficient use of wireless frequencies.

Popularization of AHS-i will depend on a unified system specification in the domestic Japanese market and later in the global market. Mitsubishi Electric has extensive experience in mobile phones for vehicle and handheld use, as well as in practical ETC systems. These make a strong foundation for system studies and technology development for AHS-i.

**Roadside Equipment Networks**

The roadside equipment may also support other ITS systems such as VICS and ETC along with AHS-i. Sufficiently high bandwidth will be needed to support these services and the anticipated multimedia communications.

AHS-i will require first and foremost that the network offer realtime performance so that the system can deliver timely warnings of roadway obstructions and other hazards. The equipment will probably include monitoring cameras and base stations for road-to-vehicle communications. Interface specifications should support this diversity.

Table 2 Functions and Performance for Implementing AHS-i Roadside Processing Equipment

System Aspects	Roadside processing equipment	Weatherproof enclosure, fanless diskless design for reliability
	Available sensor types	Visible, infrared, ultrasonic, loop antenna
	Max. sensors	8
	Information delivery equipment	Electric signboards
Detection items	Vehicles, both stopped and moving (adjustable detection speed)	
	Oncoming vehicle traffic	
	Traffic jams (selectable)	
	Out-of-lane vehicles (selectable)	
	Vehicle size classification	
	Motorcycles, bicycles	
	Pedestrians	
Information processing functions	Roadway obstructions	
	<ul style="list-style-type: none"> <li>- Display content, display timing parameters</li> <li>- Optional image transmission to control center</li> <li>- Self diagnostic and remote maintenance functions</li> </ul>	

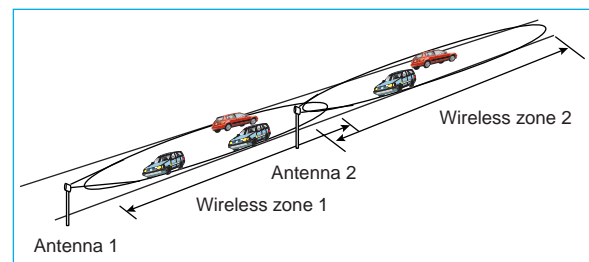

Fig. 3 Road-to-vehicle communication system.

Mitsubishi Electric is commercializing MELNET-R155 Series 155Mbps direct multiplexed SDH network equipment (Table 3.) The Mitsubishi RTnet 150 Series meets needs for ATM products.

**Partitioning System Functions Between Roadside and Vehicle Equipment**

Coordination between the roadside communications infrastructure and passing vehicles is the basis for improving safety, efficiency and environmental quality of road transport. Considerations affecting the partitioning of functions between roadside equipment and vehicles include cost, reliability, expandibility and ease of operation. The article discusses functional considerations. Functions difficult to implement in vehicle equipment that can be efficiently processed by roadside equipment include wide-area functions, and functions shared by or involving multiple vehicles. Functions efficiently handled independently by vehicles include functions requiring rapid processing, functions that can be performed by the vehicle autonomously, and functions only useful for an independent vehicle.

Here we examine the partitioning of recognition, decision-making, operation, and control functions between vehicle and roadside equipment.

**RECOGNITION.** The vehicle can determine its own position, intervehicle spacing and monitoring for side views. The roadside equipment must observe items difficult for a vehicle to determine independently, such as road obstacles hidden from the driver's view, information on traffic jams, closed lanes, roadway construction, and positions of vehicles without AHS-i.

**DECISIONS.** Functions that are difficult to implement in vehicle electronics are assigned to roadside equipment. These include speed decisions for a vehicle to stop cooperating with a group of vehicles, predicting behavior of road obstacles, and identifying obstacles. Functions that can be assigned to the vehicles include automatic lane-tracking decisions, emergency stop decisions, and "speeding" warnings.

Table 3 Major specifications of MELNET-R155 SDH Networks

Network type	Duplex loop
Bandwidth	155.52Mbps
Access system	SDH handover multiplexing and token passing
Communications formats	1:1, 1:N, N:N (bridge)
Max. nodes	127
Node spacing	40km for 1.3μm wavelength, 80km for 1.56μm wavelength
Interfaces	2 or 4W audio output, telephone interface, 1.5 or 6.3 Mbps G.703 interface, 2Mbps TTC interface, NTSC video interface with internal MPEG2 codec, low-speed data interfaces X.21, V.24, V.28 at 9,600bps max., Ethernet LAN, others
Circuit capacity	2,016 64kbps channel equivalent
RAS Functions	Redundant power supply modules, loopback during ring network interruption, hot plug capabilities, loopback diagnostic functions
Administration functions	Ring configuration monitoring Remote reconfiguration Node equipment monitoring Terminal interface setting Event logging

**OPERATION AND CONTROL.** In general, control decisions must be made quickly, so most are assigned to the vehicle. Roadside functions include delivery of control commands for grouped vehicles, instructions for cooperative vehicle control decisions.

This partitioning of functions is likely to change as AHS evolves from AHS-i (information delivery) to AHS-c (driving control assistance). The accuracy of recognition functions differs between AHS-i and AHS-c, although the division of functions between road and vehicle equipment is substantially identical. Further changes to this partitioning scheme are conceivable. Under AHS-i, decision and command functions are left to the driver based on information supplied. However, under AHS-c, roadside equipment plays a larger role, making decisions to coordinate emergency decelerating or stopping of vehicles and contributing to efficiency benefits through traffic planning.

Instructions for the spacing between vehicles are delivered by the roadside equipment based on macroscopic considerations, while it is up to the vehicles to set speed and vehicle spacing control operations based on these instructions. Mitsubishi Electric is working on the recognition, decision-making and control capabilities of roadside equipment using ITS simulations.

Mitsubishi Electric is committed to developing advanced technologies for implementing AHS-i, AHS-c and AHS-a according to AHSRA's development policy.□

# Simulation Environment for Intelligent Transport Systems

by Hiroyuki Kumazawa and Masayuki Oishi\*

Intelligent transport systems (ITSs) seek to coordinate the functioning of cars, drivers and roadway. Evaluating their usefulness requires the ability to determine the influence each of these factors has on the others. Simulation tools have already been developed to model traffic flow characteristics (road-traffic simulation), analyze behavior of individual vehicles (vehicle-dynamics simulation) and simulate the roadway environments (road-environment simulation.)

These tools, illustrated in Fig. 1, treat limited aspects of traffic behavior. For example, a driving simulator involves the combination of road-traffic simulation and road-environment simulation. Driver-car interactions, car-roadway interactions, the influence of the road environment on the driver, and the interaction of driver and roadway through the vehicle dynamics simulation can similarly be known. However, prior simulations have neglected to evaluate the interactions between vehicles sharing the road and the potential of information technology on clarifying these dynamics.

We aim to perform these simulations and integrate them in realtime so that test drivers can participate in the simulation with an immediacy comparable to actual driving. This article reports on the configuration of ITS simulators, their technical features, and typical simulation results.

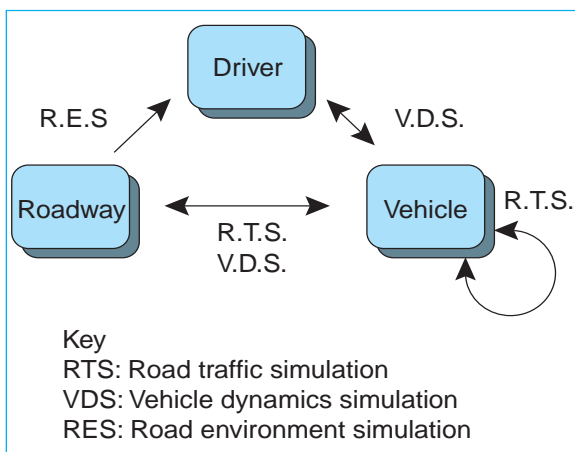

Fig. 1 Simulation types.

## Configuration

In the integrated simulation system proposed here, a simulation controller manages the three simulations listed above. Information is delivered to the user via a multifunction ITS terminal. These functional blocks operate independently in a distributed computing model that supports realtime simulation. The driving experience is reproduced using three 120-inch projection monitors surrounding a driver's seat equipped with a steering wheel, accelerator and brake pedals that receive driver inputs.

**ROAD-TRAFFIC SIMULATION.** This is a microscopic traffic-flow simulator based on an autonomous vehicle model. This autonomous vehicle model has two components: one models driver decisions and the other models vehicle motion using speed and position data based on vehicle operating characteristics. Within this model, cars can be driven independently along the roadway network under widely varying traffic conditions. The simulation can also accept data from driver-operated vehicles modeled through the vehicle dynamics simulation, allowing it to reflect the effects of manually driven vehicles on traffic conditions.

**VEHICLE-DYNAMICS SIMULATION.** Steering wheel angle, brake pressure and throttle position serve as control inputs for modeling vehicle movement. The simulation represent vehicle dynamics with mechanical, control and drive models. The simulation supports nine degrees of freedom: three degrees of freedom in vehicle movement over a flat roadway, four degrees of freedom in wheel rotation and two degrees of freedom in engine acceleration delay and rotation speed.

**ROAD-ENVIRONMENT SIMULATION.** This simulation renders a 3D driver's view of the roadway environment and vehicle traffic movements on multiple large screens. It begins with a particular roadway environment, adding in traffic conditions from the road traffic simulation, and vehicle movement data from the vehicle dynamics simulation. Data from actual freeways and

\*Hiroyuki Kumazawa is with the Industrial Electronics @ Systems Laboratory and Masayuki Oishi is with the ITS Business Development Group.

their surrounding geography are used to make the simulation as realistic as possible. The simulation can also include weather effects such as fog and icy roads. The simulation detects vehicle collisions, which are represented through sound effects and through changes in front windshield and rearview mirror views.

**SIMULATION CONTROLLER.** The time interval and type of data differ among the simulations. The road-traffic simulation data is expressed in two dimensions whereas the vehicle-dynamics simulation and road-environment simulation are conducted in three dimensions. The simulation controller maintains synchronization of the simulations based on the timing of the data conversion and display subsystems so that the roadway traffic and vehicle dynamics data can act on each other to yield a 3D computer-graphic representation of the driver's experience.

**MULTIFUNCTION TERMINAL FOR ITS APPLICATIONS.** This terminal software runs on navigation systems for the Windows 95/98/NT platform. In addition to the normal navigation functions, it serves as a testbed to investigate information-delivery timing and how to provide drivers with information for an advanced cruise-assist function. Potential information offerings include recommended speed and vehicle spacing, accident data, weather updates and road-surface conditions. Visual and auditory data presentations are provided.

### Technical Innovations

**SIMULATION DATABASE.** The simulations are run against a background of common roadway information that remains constant. The roadway-traffic simulation uses data describing the roadway network. The vehicle-dynamics simulation requires description of road structure, such as gradients and surface conditions. The roadway-environment simulation needs a 3D data set describing the nearby geographical and architectural features.

We have considered several approaches to implementing this database. One is to build a separate database for each simulation. Execu-

tion is fast because each simulation has ready access to the data it needs, however keeping the databases consistent increases maintenance costs.

A second approach is to use a common database for all the simulations. This lowers the cost of maintaining the database, but simulation execution slows due to the computational costs associated with data conversion. We adopted the first approach to meet our primary purpose of real-time execution.

**SYNCHRONIZATION.** Synchronization of the simulators' data streams is a design issue because the driver's view is generated through the coordinated activity of several simulations. During the simulation, the roadway-traffic and vehicle-dynamics simulators operating at different time increments deliver their results to the simulation controller. The controller passes vehicle location information to the road-traffic simulator, enabling it to recognize a manually piloted vehicle.

Execution increments are 100ms for the road-traffic simulation, 1~3ms for the vehicle-dynamics simulation, and 30ms for the road-environment simulation. To synchronize these varying time increments, the road-environment simulation communicates the display timing for each frame to the simulation controller, which uses this signal to initiate data transmission for the next frame to the road-environment simulation. The simulation data needed at a particular instant for a display frame is derived by interpolating simulation data between increments, or by a process described as "dead reckoning." The road environment simulation receives this data and displays it with 3D perspective synchronized with the frame display clock.

**IMPLEMENTING AHS-i SERVICES.** The ITS simulator can support information services such as AHS-i, which offers speed and following distance recommendations to maintain safe travel. We propose this AHS-i system based on the high-safety models developed for managing rail systems. Delivering this data to the driver can contribute to a safer journey. The minimum safe

following distance  $L_s$  is defined as the distance that will allow the driver sufficient time to respond to sudden braking by the vehicle he or she is following. We define  $V_r$  as the velocity recommended to maintain the safe following distance. Assuming equal deceleration by the two vehicles,  $L_s$  and  $V_r$  are given by the following equations:

$$L_s = V_f \left( \frac{V_f + \tau}{\beta_n} \right) - \frac{V_i^2}{2\beta_e} + d \dots \dots \dots \text{(Eq. 1)}$$

$$V_r = \beta_n \tau + \left[ (\beta_n \tau)^2 + 2\beta_n \tau (L + \frac{V_i^2}{2\beta_e} - d) \right]^{1/2} \dots \text{(Eq. 2)}$$

where  $V_i$  is the preceding car's velocity in m/s,  $V_f$  is the following car's velocity in m/s,  $\beta_e$  is the emergency braking deceleration in m/s<sup>2</sup>, and  $\beta_n$  is the maximum normal braking deceleration, also in m/s<sup>2</sup>,  $\tau$  is the delay time in seconds, and  $d$  is the minimum following distance. Fig. 2 shows minimum safe following distances (negative values correspond to zero).

**Sample Simulation**

Fig. 3 shows the first of our examples, when the piloted vehicle blocks the progress of the car following behind. The roadway traffic simula-

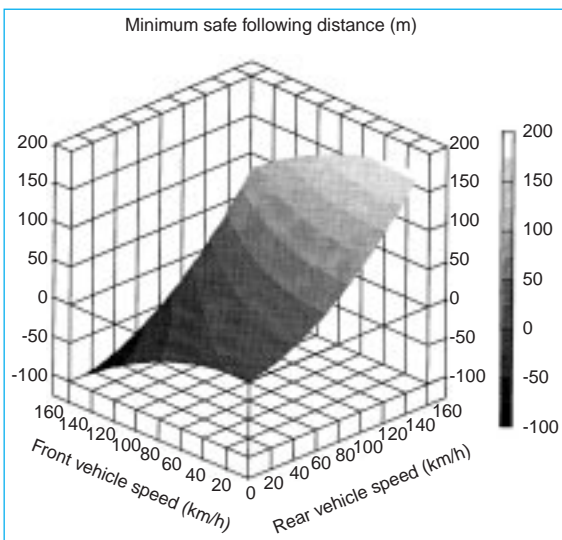

Fig. 2 Minimum safe following distances.

tion recognizes the behavior of the piloted vehicle, and indicates the the car movement will affect nearby vehicles. Fig. 4 shows how AHS-i information services delivered from a roadside radio beacon would inform the driver of icy road conditions via display on the multifunction terminal. Fig. 5 shows simulation of AHS-a, an automated safe-driving support system that maintains the car in a safe direction of travel through dense fog assisted by the roadside infrastructure.



Fig. 3 Simulation of a driver obstructing the vehicle behind him.



Fig. 4 AHS-i safety-enhancement display.



Fig. 5 AHS-a automatic driving display.

We have described an ITS simulator that can be used to design and evaluate large-scale ITS systems. The authors hope that these simulation tools will contribute to wider application of ITS technologies. We are continuing to develop these simulations with an emphasis on practical system design and new theories of intelligent roadway infrastructure. □

# MELBA Enterprise Application Integration Software Using Agent Technology

by Shigenori Kino and Yoshitaka Ogawa\*

This article introduces MELBA, Mitsubishi Electric's enterprise application integration support software for linking business software systems over networks. MELBA stands for "multi enterprise links by agents."

## Background

Fig. 1 illustrates the conventional implementation of a customer service support application. Company A contracts its electronic equipment repair and maintenance to Company B. Using a business application from Company X, Company A manages data for each piece of equipment including installation site and service contract dates.

Company B has many clients like Company A that outsource their maintenance and repair services. Company B uses business application software from Company Y to manage work orders, maintenance contracts, repair histories, and part and tool data. Both Company A and

Company B use a type of business application software package called Enterprise Resource Planning (ERP) that improves the efficiency of the company's clerical and administrative operations.

These packages generally define a number of views at the top level of the database schema, perform processing functions according to preprogrammed rules in support of clerical operations and analyze data generated by these transactions to generate reports that can inform management decisions.

Due to the complexity of the different data views, simple file transfers are insufficient to effectively integrate the data of two companies each using two separate business applications.

Almost all companies that introduce a business application package customize it to reflect details of their particular enterprise. This means that two companies even using the same solution may discover differences in their data that

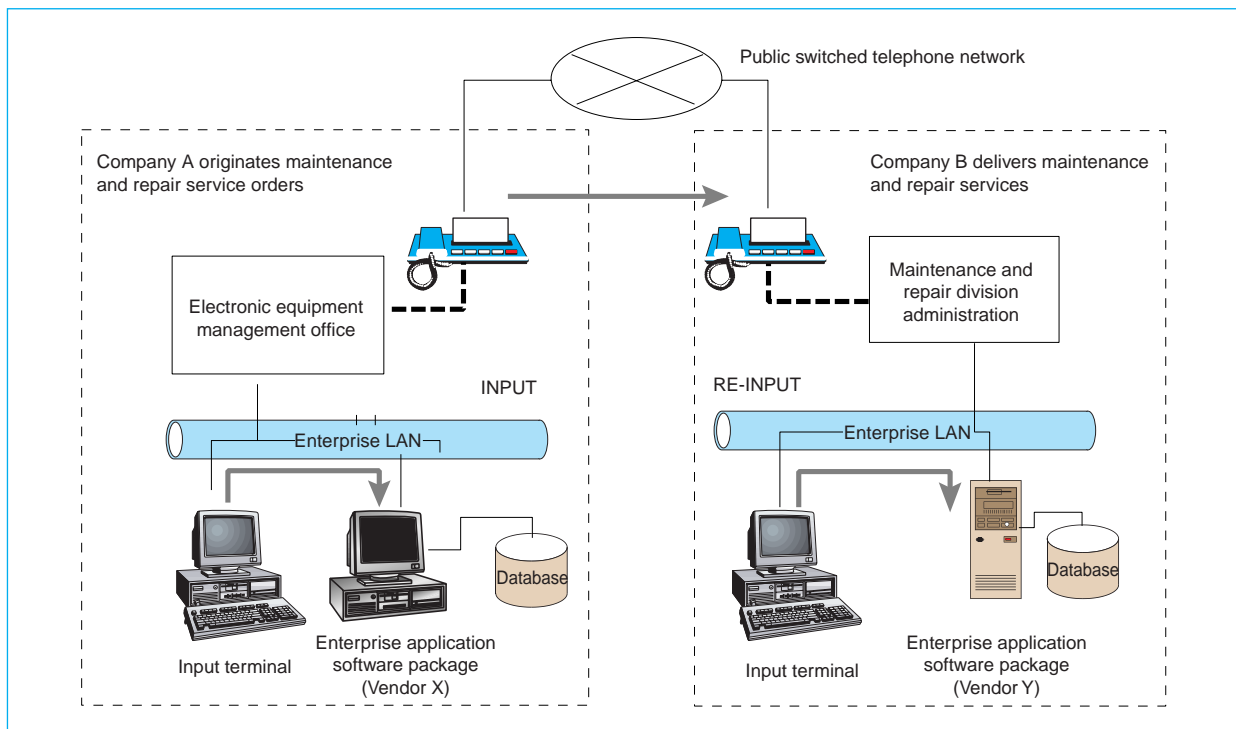

Fig. 1 Customer service support system with conventional implementation.

\*Shigenori Kino is with Information Technology R&D Center and Yoshitaka Ogawa with Information Systems Engineering Center.

are difficult to bridge. Further, every company has information it would prefer to keep private, such as its list of clients and the discounts it gives to some of them. So there needs to be a way to determine what information is appropriate to exchange with which business partner.

**Key Technologies**

Integrated enterprise applications must satisfy the following conditions:

1. Minimal communication costs
2. Maintaining the privacy of enterprise information
3. Standardized mechanism for exchanging data between enterprise software systems including existing and legacy systems
4. Common software resources so that customization effort and cost is minimal

The first two conditions can be met by using encrypted, authenticated tunnels over the Internet to accomplish the data transfers, with fire-

walls and other technologies achieving satisfactory security at a reasonable cost.

The popularity of XML (extensible markup language) and related technologies suggests this as a likely standard for enterprise data exchange, the third condition. Enterprise applications are typically customized to reflect the work flow and business rules and procedures of a particular company therefore, at a minimum, software components will have to be developed for various types of enterprises and for various product or service categories. This raises the cost of integrated applications, and is a key reason for slow adoption of integrated enterprise application software. The popularity of enterprise resource planning (ERP) for supply chain management (SCM) also suggests that there is a need to integrate systems across enterprise boundaries.

Software components developed for particular types of businesses can help reduce the custom development costs associated with implement-

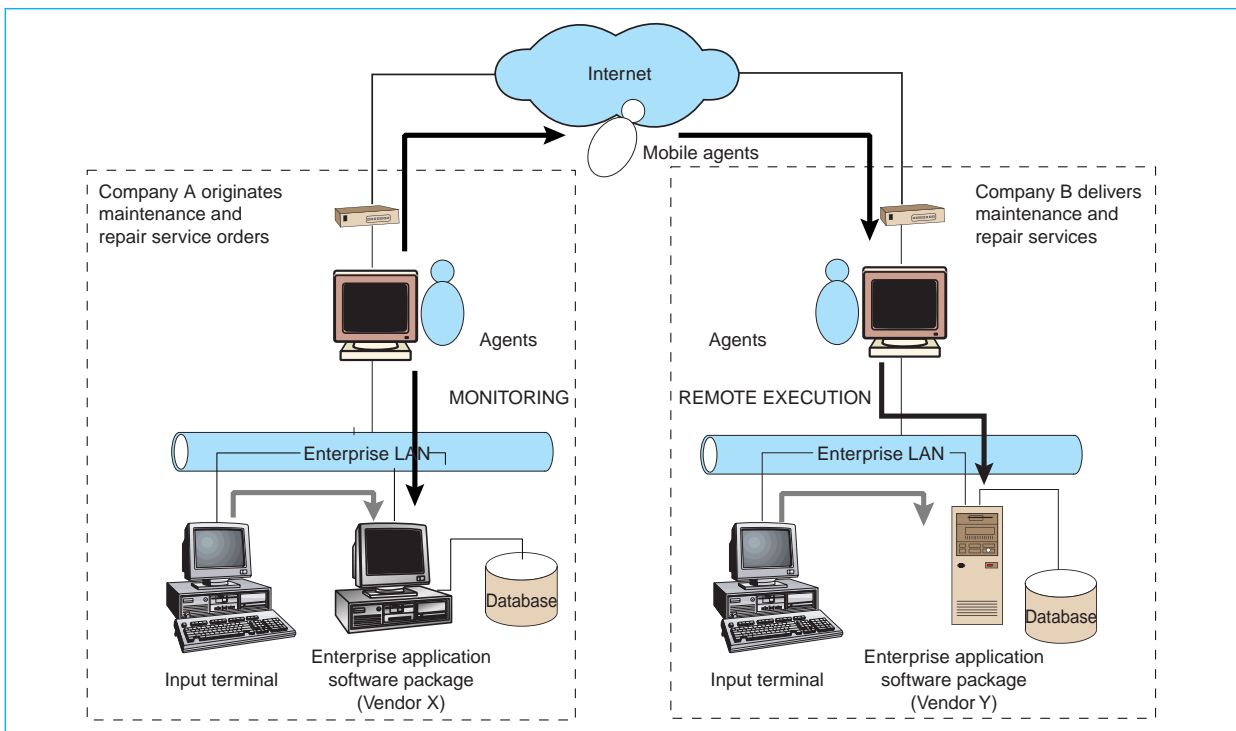

Fig. 2 Enterprise application integration using agent technology.



ing EAI, satisfying the fourth condition.

**MELBA: Using Agent Technology to Mediate EAI**

The integration capabilities of MELBA reduce the software development required to meet the requirements of various tasks and enterprises. We investigated conventional approaches to coordinating enterprise applications, then developed a series of agents to accomplish tasks previously performed manually. Fig. 2 illustrates this integration strategy.

We will now consider the task of integrating the enterprise software of Company A, which is requesting a service, and Company B, which is providing it. The transactions performed by agents on behalf of their respective owners include the following steps:

- Generating the order from Company A to Company B
- Detecting that an order is pending and de-

termining the transaction partners (Companies A and B)

- Selecting data items for transmission
- Converting data supplied by Company A to a common format
- Transferring data using authentication and encryption
- Converting the data to Company B format
- Checking input rules and executing inputs

**MELBA Configuration**

Fig. 3 shows the MELBA software configuration for Company A running helpdesk application from Vendor X and Company B running a field service application from Vendor Y. Access interfaces for each enterprise application are delivered as application plug-ins. The Concordia server is a mobile agent execution and management environment developed by Mitsubishi Electric that runs on a Java virtual machine. MELBA Bridge provides the interface between Concordia

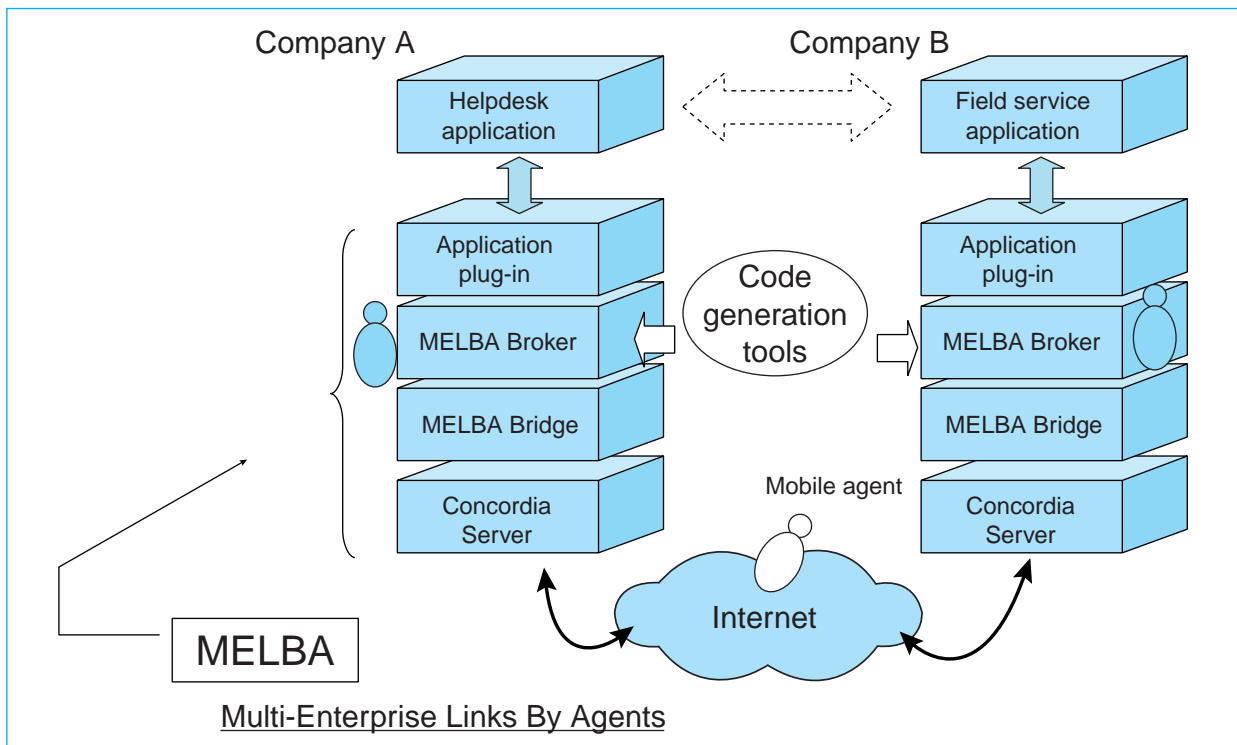

Fig. 3 System configuration under MELBA.

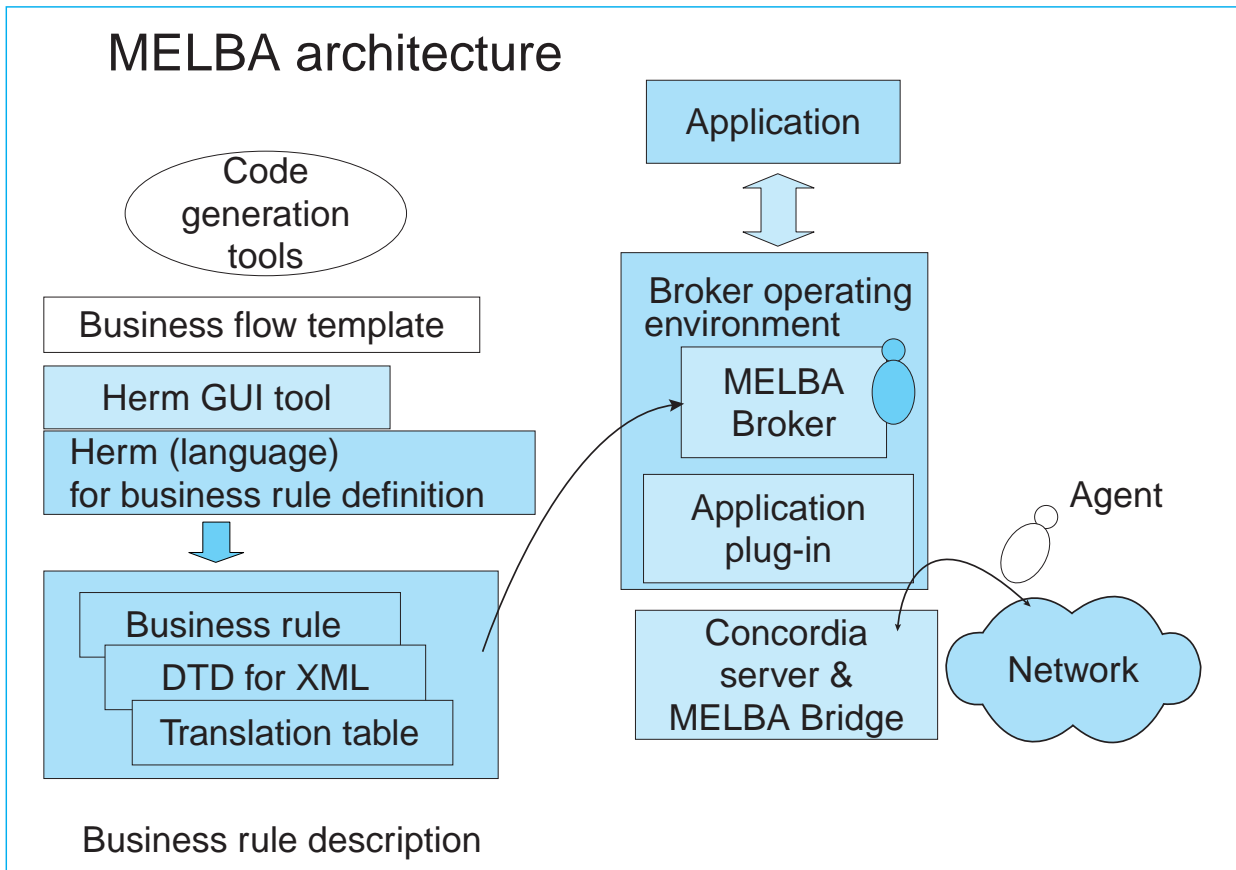

Fig. 4 MELBA architecture and code generation tools.

and MELBA Broker. MELBA Broker determines permissible data access procedures based on priority, order of access and other parameters, and supplies a plug-in—a mobile agent—that reads and writes enterprise data and converts data between the application’s native format and a common format used for transmission. An agent residing in the MELBA Broker must be prepared for each user and application.

Mitsubishi Electric has developed both the MELBA Broker program code and code generation tools that produce the access rules and data conversion rules. This approach offers clients the ability to implement a MELBA Broker with minimum software development. Fig. 4 illustrates the code generation tools.

The MELBA Broker executable program works in association with business rule definitions, including exception processing and conversion procedures, data conversion rule definitions and data definition tables (DDTs) for converting to XML. Mitsubishi Electric has defined Herm, an intermediate language for system developers that provides a uniform environment for generating code for the rules and agent processing code. Once the MELBA Broker is specified in Herm, the Herm compiler can automatically create the MELBA Broker executable linked with the appropriate rule definitions.

The company is also developing a GUI tool that enables developers to build systems by entering EAI specifications on the screen. This will not require Herm programming. □

# mitsubishi electric overseas network (Abridged)

Country	Address	Telephone	
U.S.A.	Mitsubishi Electric America, Inc.	5665 Plaza Drive, P.O. Box 6007, Cypress, California 90630-0007	714-220-2500
	Mitsubishi Electric America, Inc. Sunnyvale Office	1050 East Arques Avenue, Sunnyvale, California 94086	408-731-3973
	Mitsubishi Electronics America, Inc.	5665 Plaza Drive, P.O. Box 6007, Cypress, California 90630-0007	714-220-2500
	Mitsubishi Consumer Electronics America, Inc.	9351, Jeronimo Road, Irvine, California 92618	949-465-6000
	Mitsubishi Semiconductor America, Inc.	Three Diamond Lane, Durham, North Carolina 27704	919-479-3333
	Mitsubishi Electric Power Products Inc.	512 Keystone Drive, Warrendale, Pennsylvania 15086	724-772-2555
	Mitsubishi Electric Automotive America, Inc.	4773 Bethany Road, Mason, Ohio 45040	513-398-2220
	Astronet Corporation	3805 Crestwood Parkway Suite 400 Duluth, Georgia 30096	770-638-2000
	Powerex, Inc.	Hills Street, Youngwood, Pennsylvania 15697	724-925-7272
	Mitsubishi Electric Information Technology Center America, Inc.	201 Broadway, Cambridge, Massachusetts 02139	617-621-7500
Canada	Mitsubishi Electric Sales Canada Inc.	4299 14th Avenue, Markham, Ontario L3R 0J2	905-475-7728
Mexico	Melco de Mexico S.A. de C.V.	Mariano Escobedo No. 69, Tlalnepantla, Edo. de Mexico Apartado Postal No.417, Tlalnepantla	5-565-4925
Brazil	Melco do Brazil, Com. e Rep. Ltda.	Av. Rio Branco, 123, S/1504-Centro, Rio de Janeiro, RJ CEP 20040-005	21-221-8343
	Melco-TEC Rep. Com. e Assessoria Tecnica Ltda.	Av. Rio Branco, 123, S/1507, Rio de Janeiro, RJ CEP 20040-005	21-221-8343
Argentina	Melco Argentina S.A.	Florida 890-20-Piso, Buenos Aires	1-311-4801
Colombia	Melco de Colombia Ltda.	Calle 35 No. 7-25, P.12 A. A. 29653 Santafe de Bogota, D.C.	1-287-9277
U.K.	Mitsubishi Electric U.K. Ltd. Livingston Factory	Houston Industrial Estate, Livingston, West Lothian, EH54 5DJ, Scotland	1506-437444
	Apricot Computers Ltd.	3500 Parkside, Birmingham Business Park, Birmingham, B37 7YS, England	121-717-7171
	Mitsubishi Electric Europe B.V. Corporate Office	Centre Point (18th Floor), 103 New Oxford Street, London, WC1A 1EB	171-379-7160
France	Mitsubishi Electric France S.A. Bretagne Factory	Le Piquet 35370, Etelles	2-99-75-71-00
The Netherlands	Mitsubishi Electric Netherlands B.V.	3rd Floor, Parnassustoren, Locatellikade 1, 1076 AZ, Amsterdam	020-6790094
Belgium	Mitsubishi Electric Europe B.V. Brussels Office	Avenue Louise 125, Box 6, 1050 Brussels	2-534-3210
Germany	Mitsubishi Electric Europe B.V. German Branch	Gothaer Strasse 8, 40880 Ratingen	2102-4860
	Mitsubishi Semiconductor Europe GmbH	Konrad-Zuse-Strasse 1, D-52477 Alsdorf	2404-990
Spain	Mitsubishi Electric Europe B.V. Spanish Branch	Polígono Industrial "Can Magi", Calle Joan Buscallà 2-4, Apartado de Correos 420, 08190 Sant Cugat del Vallés, Barcelona	3-565-3131
Italy	Mitsubishi Electric Europe B.V. Italian Branch	Centro Direzionale Colleoni, Palazzo Persero-Ingresso 2, Via Paracelso 12, 20041 Agrate Brianza	39-60531
China	Mitsubishi Electric (China) Co., Ltd.	Room No. 1609 Scite Building (Noble Tower), Jianguo Menwai Street, Beijing	10-6512-3222
	Mitsubishi Electric (China) Co., Ltd. Shanghai Office	39th Floor, Shanghai Senmao International Building, 101, Yincheng Road (E), Pudong New Area, Shanghai	21-6841-5300
	Mitsubishi Electric (China) Co., Ltd. Guangzhou Office	Room No. 1221-4, Garden Tower, Garden Hotel, 368, Huanshi Dong Lu, Guangzhou	20-8385-7797
	Shanghai Mitsubishi Elevator Co., Ltd.	811 Jiang Chuan Road, Minhang, Shanghai	21-6430-3030
Hong Kong	Mitsubishi Electric (H.K.) Ltd.	41st Floor, Manulife Tower, 169 Electric Road, North Point	2510-0555
	Ryoden (Holdings) Ltd.	10th Floor, Manulife Tower, 169 Electric Road, North Point	2887-8870
	Ryoden Merchandising Co., Ltd.	32nd Floor, Manulife Tower, 169 Electric Road, North Point	2510-0777
Korea	KEFICO Corporation	410, Dangjung-Dong, Kunpo, Kyunggi-Do	343-51-1403
Taiwan	Mitsubishi Electric Taiwan Co., Ltd.	11th Floor, 88 Sec. 6, Chung Shan N. Road, Taipei	2-2835-3030
	Shihlin Electric & Engineering Corp.	75, Sec. 6, Chung Shan N. Road, Taipei	2-2834-2662
	China Ryoden Co., Ltd.	Chung-Ling Bldg., No. 363, Sec. 2, Fu-Hsing S. Road, Taipei	2-2733-3424
Singapore	Mitsubishi Electric Singapore Pte. Ltd.	152, Beach Road, #11-06/08, Gateway East, Singapore 189721	295-5055
	Mitsubishi Electric Sales Singapore Pte. Ltd.	307, Alexandra Road, #05-01/02, Mitsubishi Electric Building, Singapore 159943	473-2308
	Mitsubishi Electronics Manufacturing Singapore Pte. Ltd.	3000, Marsiling Road, Singapore 739108	269-9711
	Mitsubishi Electric Asia Co-ordination Centre	307, Alexandra Road, #02-02, Mitsubishi Electric Building, Singapore 159943	479-9100
Malaysia	Mitsubishi Electric (Malaysia) Sdn. Bhd.	Plo 32, Kawasan Perindustrian Senai, 81400 Senai, Johor Daruel Takzim	7-5996060
	Antah Melco Sales & Services Sdn. Bhd.	No.6 Jalan 13/6, P.O. Box 1036, 46860 Petaling Jaya, Selangor, Daruel Ehsan	3-755-2088
	Ryoden (Malaysia) Sdn. Bhd.	No. 14 Jalan 19/1, 46300 Petaling Jaya Selongar Daruel Ehsam	3-755-3277
Thailand	Kang Yong Watana Co., Ltd.	28 Krungthep Kreetha Road, Huamark, Bangkok, Bangkok 10240	2-731-6841
	Kang Yong Electric Public Co., Ltd.	67 Moo 11, Bangna-Trad Road KM. 20, Bangplee, Samutprakarn 10540	2-337-2431
	Melco Manufacturing (Thailand) Co., Ltd.	86 Moo 4, Bangna-Trad Road KM. 23, Bangsaothong, Samutprakarn 10540	2-312-8350-3
	Mitsubishi Elevator Asia Co., Ltd.	700/86-92, Amata Nakorn Industrial Estate Park2, Moo 6, Bangna-Trad Road, Tambon Don Hua Roh, Muang District, Chonburi	38-213-170
	Mitsubishi Electric Asia Coordination Center (Thailand)	17th Floor, Bangna Tower, 2/3 Moo 14, Bangna-Trad Highway 6.5 Km, Bangkok, Bang Plee, Samutprakarn 10540	2-312-0155-7
Philippines	International Elevator & Equipment, Inc.	K.m. 23 West Service Road, South Superhighway, Cupang, Muntinlupa, Metro Manila	2-842-3161-5
Australia	Mitsubishi Electric Australia Pty. Ltd.	348 Victoria Road, Rydalmere, N.S.W. 2116	2-9684-7777
New Zealand	Melco New Zealand Ltd.	1 Parliament St., Lower Hutt, Wellington	4-560-9100
Representatives			
Korea	Mitsubishi Electric Corp. Seoul Office	Daehan Kyoyuk Insurance Bldg., Room No. 2205, #1,1-ka, Chongno-ku, Seoul	2-732-1531-2
India	Mitsubishi Electric Corp. New Delhi Liaison Office	Dr. Gopal Das Bhawan (8th Floor), 28 Barakhamba Road, New Delhi 110001	11-335-2343
Viet Nam	Mitsubishi Electric Corp. Ho Chi Minh City Office	18th Floor, Sun Wah Tower, 115 Nguyen Hue Street, District 1, Ho Chin Minh City	8-821-9038

