

*VOL. 92/DEC. 2000*

# MITSUBISHI ELECTRIC **ADVANCE**

Iron and Steel Plant Electrical Equipment Edition



## Iron and Steel Plant Electrical Equipment Edition

### CONTENTS

#### TECHNICAL REPORTS

##### OVERVIEW

<b>The Contributions of Information Technology to the Steel Industry</b> .....	1
--	---

by *Kyoji Yonemasu*

<b>A Total Plant Operation and Maintenance Support System</b> .....	2
---	---

by *Kimio Yamanaka, Yasushi Kobayashi and Yukihiro Yoshida*

<b>A System for Automating Coke Machines</b> .....	6
--	---

by *Naokazu Watanabe and Takao Muranaka*

<b>Electrical Equipment for Hot-Rolling Mills</b> .....	9
---	---

by *Ken Okamoto and Yoshiaki Nakagawa*

<b>Controlling Quality in Steel Processing Lines</b> .....	13
--	----

by *Nobuya Yamanaka and Naohiro Kubo*

<b>Variable-Speed Drive Systems for Steel Plants</b> .....	17
--	----

by *Hiroyuki Masuda and Masaru Toyoda*

<b>Computer Systems for Controlling Steel Plants</b> .....	21
--	----

by *Kazuo Sena and Shigehiko Matsuda*

<b>Control Systems for Steel Plants</b> .....	27
---	----

by *Yuuji Takahashi and Keiichi Fuse*

<b>A Quality Control and Diagnostic System for Hot-Rolling Mills</b> .....	30
--	----

by *Yoshinori Wakamiya and Isoko Nitta*

<b>A Camber-Profile Gauge Using a Laser Scanning and Light-Guide Detection Edge Sensor</b> .....	34
--	----

by *Masayuki Sugiyama and Michihiko Hamaguchi*

*Mitsubishi Electric has a long history of research and development for electrical equipment in iron and steel plants.*

*Recently, the corporation's efforts have concentrated on using its expertise in information technology to help iron and steel plant operators minimize the total cost of ownership (TCO) by investments intended to reduce staffing needs and produce more competitive products. Our cover shows the following representative products: (1) A large-multi screen display for a plant supervisory system; (2) The MR2200 industrial computer, center of information and control systems; (3) and (4) the P2000, our main control system for production and the OPS2000 operator station that provides the human-machine interface; (5) and (6) screens from the integrated engineering support environment; (7) a diagram illustrating the basic principles of the optical sensor, a key technology in controlling product quality; and (8) variable-speed drive system.*

#### Editor-in-Chief

Shin Suzuki

#### Editorial Advisors

Haruki Nakamura  
Hiroo Fujikawa  
Keizo Hama  
Kazunori Sasaki  
Masao Hataya  
Hiroshi Muramatsu  
Takashi Ito  
Masatoshi Araki  
Hiroaki Kawachi  
Hiroshi Kayashima  
Takao Yoshihara  
Osamu Matsumoto  
Kazuharu Nishitani

#### Vol. 92 Feature Articles Editor

Yoshinori Wakamiya

#### Editorial Inquiries

Keizo Hama  
Corporate Total Productivity Management & Environmental Programs  
Mitsubishi Electric Corporation  
2-2-3 Marunouchi  
Chiyoda-ku, Tokyo 100-8310, Japan  
Fax 03-3218-2465

#### Product Inquiries

Yasuhiko Kase  
Global Strategic Planning Dept.  
Corporate Marketing Group  
Mitsubishi Electric Corporation  
2-2-3 Marunouchi  
Chiyoda-ku, Tokyo 100-8310, Japan  
Fax 03-3218-3455

*Mitsubishi Electric Advance* is published on line quarterly (in March, June, September, and December) by Mitsubishi Electric Corporation.  
Copyright © 2000 by Mitsubishi Electric Corporation; all rights reserved.  
Printed in Japan.

# Overview

## *The Contributions of Information Technology to the Steel Industry*



*by Kyoji Yonemasu\**

**T**he twentieth century saw remarkable advances in industry accompanied by a rapid expansion in the key market for iron and steel. Mitsubishi Electric Corporation has been taking a leadership role in industry in the development and supply of new technologies.

The last quarter of the century, in particular, saw dramatic advances in computers, plant controllers, drive systems and other electrical and electronic equipment for the iron and steel industry paralleling accelerating advances in semiconductor technology. These have contributed to the automation of operations and to significant improvements in yield and product quality.

We mark the dawn of the new millennium with a special edition of *Advance* featuring iron and steel plant electrical equipment and introducing some of the latest types of equipment and current trends in their development.

Unquestionably, the technological revolution in iron and steel plant equipment will continue in the quest for production innovations to ensure better quality products and higher productivity. The key phrase here is "information technology" (IT). The corporation uses its advanced IT expertise to support iron and steel plant operators by providing electrical equipment that minimizes their total cost of ownership. The lead article in this special edition proposes a total plant operation and maintenance support system for iron and steel plants.

As an integrated manufacturer of electrical and electronic equipment, Mitsubishi Electric has an extremely wide range of available technologies that it can call upon, and is integrating them in the service of the iron and steel industry. We look forward to ever closer relationships with our clients, learning how best to serve their special needs and cooperating with them in providing the best possible means of satisfying those needs.

\*Kyoji Yonemasu is with the Energy & Industrial Systems Center.

# A Total Plant Operation and Maintenance Support System

by Kimio Yamanaka, Yasushi Kobayashi and Yukihiro Yoshida\*

Mitsubishi Electric Corporation not only provides a wide range of electrical equipment used in iron and steel plants but can also supply entire systems that support overall plant operation and maintenance. These systems use solutions based on information technology (IT), and contribute to the competitive strengths of iron and steel manufacturers and to minimizing their investments in plant and equipment.

## Improving Product Quality

The iron and steel industry is currently, with very few regional exceptions, in a state of worldwide oversupply. This means that investments are being made primarily to increase products' competitive strengths or to minimize the overall cost of investments in plant and equipment. The corporation has responded to this situation by adding to its previous range of electrical

equipment for the industry, concentrating on the key themes of improved product quality, advanced labor saving, maintenance support and environmental protection. Specifically, it has applied solutions derived from revolutionary developments in IT to configure a system offering total plant operating and maintenance support, see Fig. 1. The article introduces the product development and corporate strategy behind this system.

Under the present situation of oversupply, the iron and steel industry is concentrating its efforts on improving product quality and, of course, on reducing costs. Other articles in this special edition of "Advance" will give specific examples of how product quality can be better controlled and improved, but here we note that it depends on three critically important factors.

The first of these is a super-stable and robust

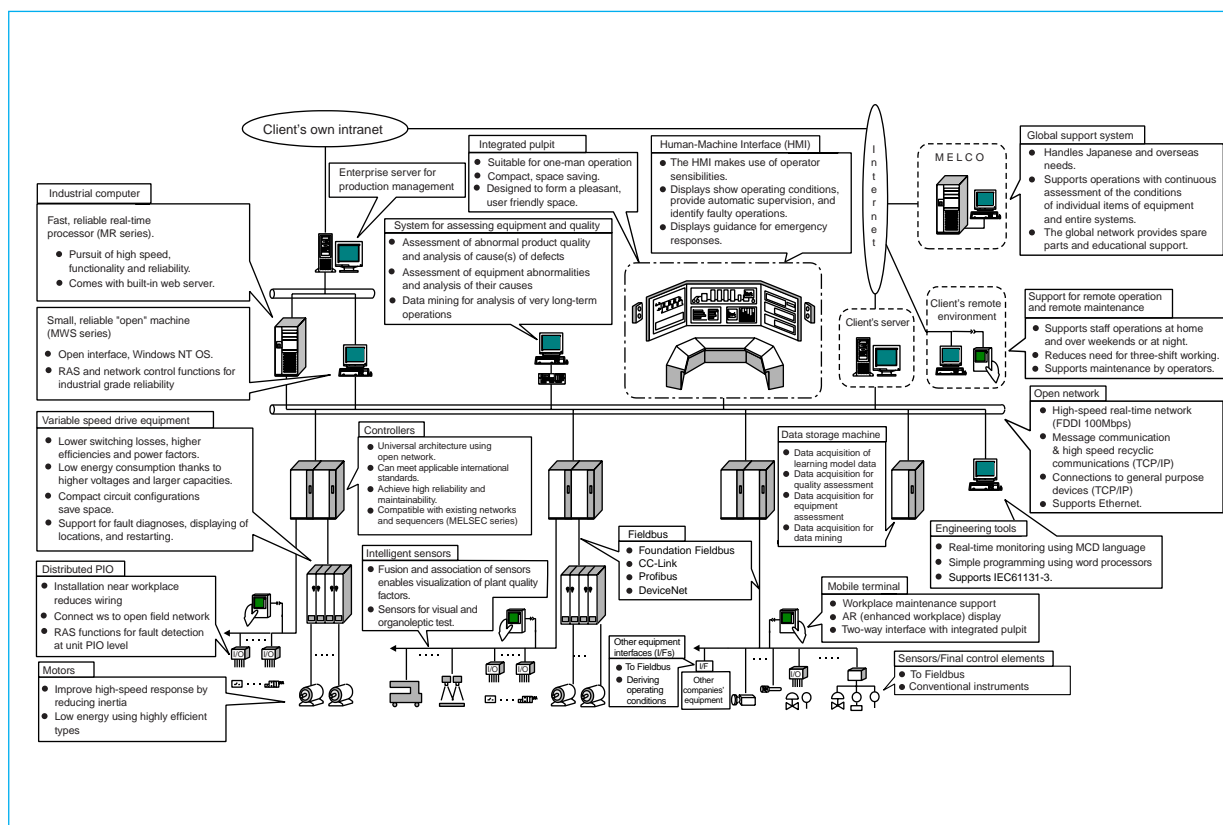

Fig. 1 A total plant operating and maintenance system

\*Kimio Yamanaka, Yasushi Kobayashi & Yukihiro Yoshida are with the Energy & Industrial Systems Center.

control system that provides “no-touch” operation, i.e., free from the frequent need for operator intervention.

The second is the automatic detection of abnormal conditions in the manufacturing process, with automatic repair and restart.

And the third is the use of intelligent sensors that can assist in the visualization of controlled processes.

The full range of automatic controls available today already ensure “no touch” operation under virtually all normal circumstances. However, they frequently depend upon intervention by skilled and experienced operators when abnormal conditions arise. The skills exercised at such times have a direct effect on product quality and yield. Improvements here call for superstable and robust control systems significantly out-performing conventional “no-touch” control systems. Such advanced systems should automatically detect abnormal operation and achieve automatic repair and restart without relying upon manual intervention by operators.

A number of different sensors and methods are currently used to detect abnormal conditions and to recover from them. In future, as more intelligent sensors are used to achieve better visualization of the processes being controlled, data-mining techniques will be used to identify operating abnormalities and their causes. Quality improvements will readily follow when the necessary repairs can be made automatically and normal operation restored without operator intervention.

#### **Advanced Labor Saving**

We are already approaching the limits of what can be achieved in labor saving for individual production lines under normal “no-touch” operation and their integrated control rooms. Further advances in labor saving will require integrated control of multiple production lines within a single control room. This, in turn, will require an infrastructure that provides not only

the previously mentioned intelligent sensors and improved process visualization but also an intranet, multimedia controllers, large multi-screen display systems, and sophisticated data-acquisition capabilities. It must also provide for one-man execution of unscheduled operations using agent functions that act for the operator, and optimum scheduling of materials handling and yard operations so as to implement fully automated, unattended processes. IT solutions will necessarily provide the technological support for these labor-saving developments.

#### **Maintenance Support**

The increased sophistication of production facilities and the move to continuous operation have made it desirable to form workplace maintenance support environments that enable operators to cope with trouble as soon as it occurs, and speed the work of maintenance by facilitating remote maintenance and the use of mobile intelligent terminals. The corporation is providing the following solutions directed at meeting these needs:

1. Remote maintenance support using the Internet (and/or an intranet).
2. Workplace maintenance support systems using mobile intelligent terminals.
3. Operator support using maintenance agent functions.

Remote maintenance support enables engineers to accurately grasp the situation via the Internet (or intranet) without necessarily visiting the workplace, and then to decide and implement the required remedial actions. This greatly reduces the number of service visits the maintenance engineers have to make to the workplace and, even when visits do prove necessary, it minimizes the time taken to implement the required measures.

Workplace support for mobile intelligent terminals enables engineers in the workplace to carry small terminals with miniature ITV cameras and displays. These can then be used to share with those in the control center images of conditions at the workplace and the operating sequences followed, and to convey instructions

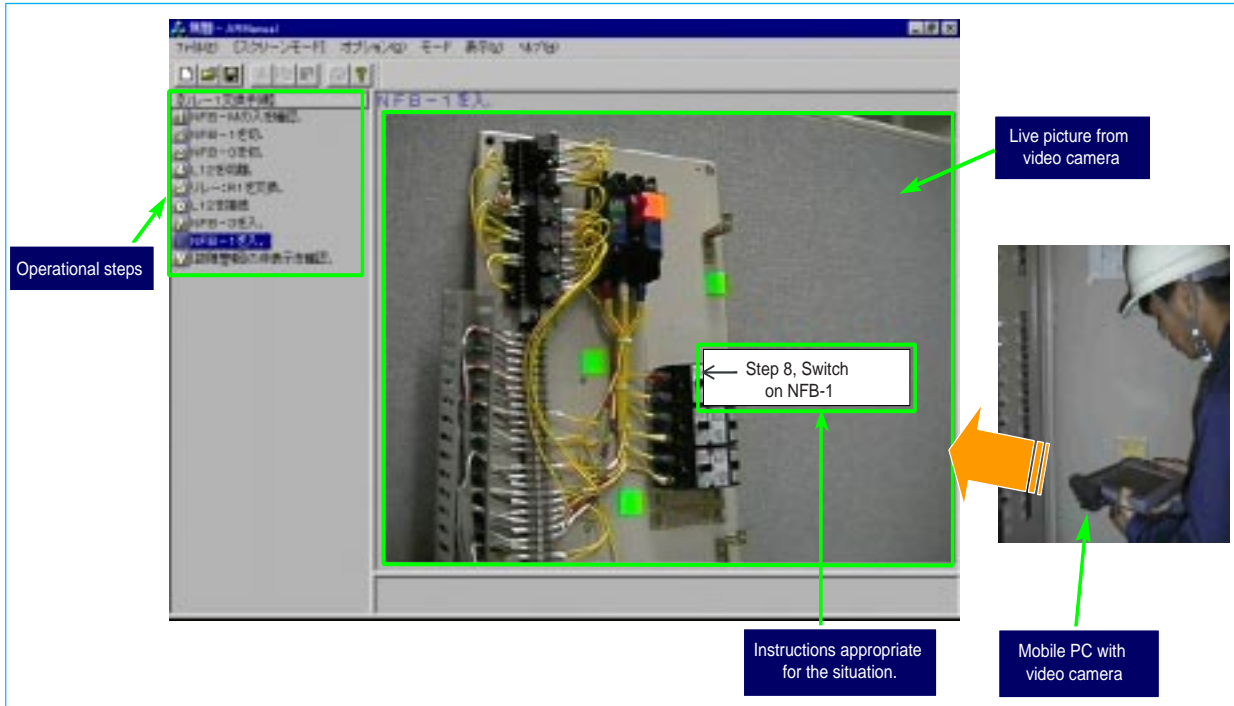

Fig. 2 Workplace maintenance support system

from the center to maintenance engineers (see Fig. 2)

To achieve fast and efficient maintenance operations with this approach requires timely access to maintenance information, with the main point being to create an environment giving integrated access to a number of databases of different kinds, including all the various maintenance related databases and the plant operating database. The corporation provides this environment in the form of a middle-ware system (Infoharness) for integrating heterogeneous information sources, see Fig. 3.

#### Addressing Environmental Concerns

As part of Mitsubishi Electric's corporate response to the quantitative targets for reduced CO<sub>2</sub> emissions set by the Kyoto Global Warming Earth Summit held in December 1999, the corporation developed the energy-saving MELTRAC-F500H high-tension inverter. This inverter clears the guidelines set for suppression of higher harmonic current with 24-phase converter inputs and com-

bins high power factor with high efficiency. By using five-level pulse-width modulation for control, it is very easy on the loads it serves. The corporation also provides a number of key technologies that address, directly or indirectly, environmental concerns. These include:

1. Optimized flow-rate control of the cooling fans for main and optimized control auxiliary motors.
2. Optimized flow-rate control of the inlet and exhaust fans for the electric room.
3. Main-motor field economizing control.
4. Optimized control of the cooling-water pumps in rolling mills.
5. Optimized control of descaling pumps.

The approaches and proposals outlined above have already been implemented in actual products and systems, some of which are already being provided to the iron and steel industry. Future developments and applications along these lines will be modified to reflect the opinions of iron-and-steel industry experts. The corporation is committed to

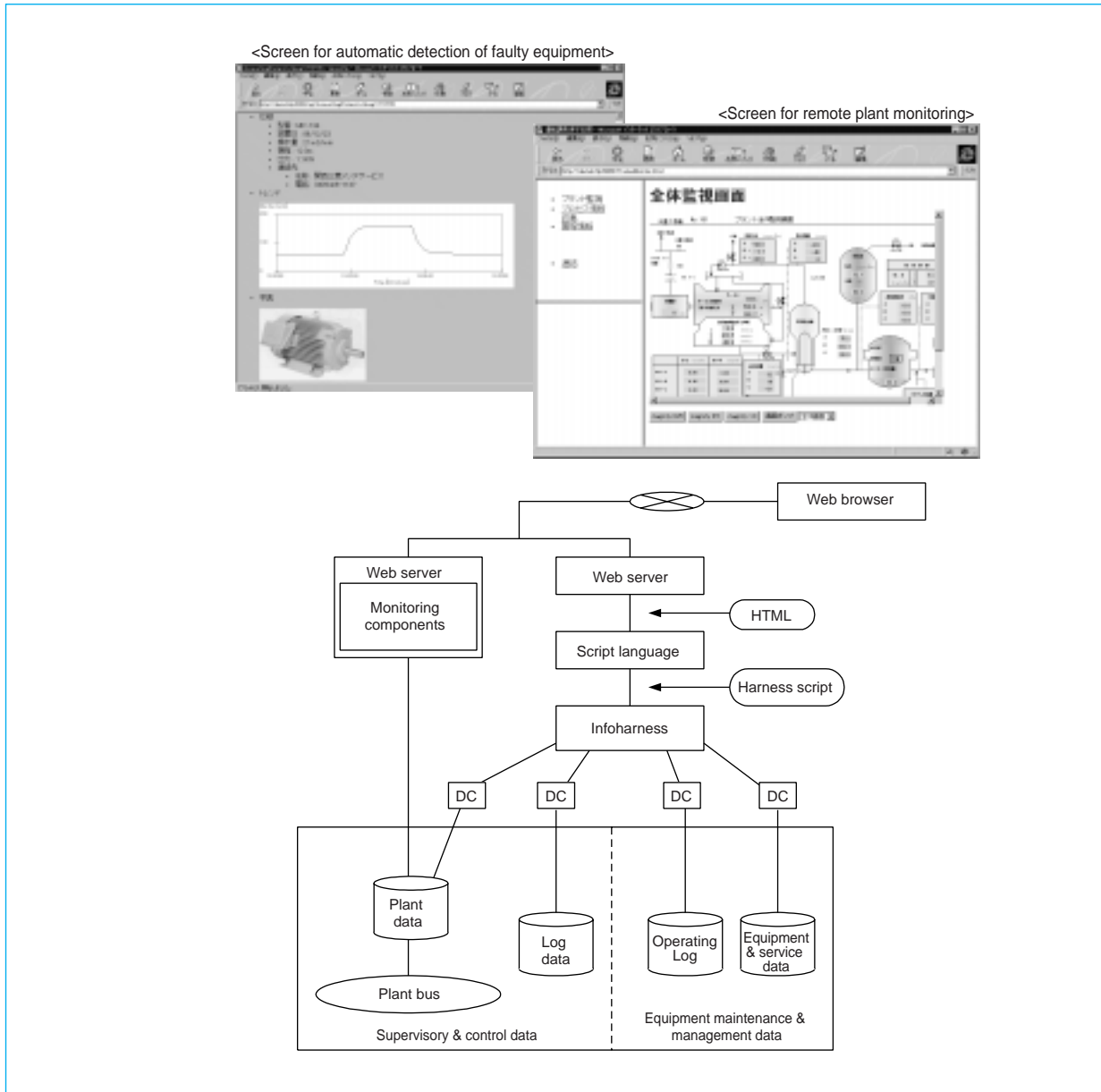

Fig. 3 An integrated system with distributed heterogeneous databases.

expanding its proposals and implementing them widely to support the iron and steel industry in its efforts to reduce the total cost of ownership. □

**Note:**

1. UNIX is a registered trademark licensed by X/Open Co., Ltd. in the US and other countries.

2. Windows, Windows NT and Active-X are registered trademarks of the US company Microsoft Corp. in the US and other countries.

3. Java is a registered trademark of the US company Sun Microsystems, Inc. in the US and other countries.

4. DeviceNet is a trademark of the US Open DeviceNet Vendors Association, Inc. (ODVA).

5. Ethernet is a trademark of the US company Xerox Corp.

# A System for Automating Coke Machines

by Naokazu Watanabe and Takao Muranaka\*

The automation of coke machines calls for very accurate positioning of stops and highly stable operation. Mitsubishi Electric has configured automatic systems with the required positional accuracy and achieved stable operation by adopting a combination of inductive radio and position detectors.

## A Brief Description of Coking Facilities and their Main Specifications

In recent years, automation and labor saving in coking facilities has proceeded with the twin aims of improving both productivity and the working environment. Systems for automating coke machines operate the equipment that moves in parallel with the operation of coke ovens, making possible automatic or unattended operation and generally improving efficiency.

Coke machines comprise four items of moving equipment associated with the coke oven,

and all four play their parts in coordinated operations; they are the pusher machine, the charging car, the guide car and the quenching car (see Fig. 1). The over-riding concerns in automating their operations are to achieve the required positional accuracy in bringing them to a stop, to reduce the time required to complete each operational cycle, and to ensure safety.

## System Configuration

Fig. 1 shows the typical configuration of a system for coke-machine automation. The system is broadly divided into a ground station and the various on-board stations located on the individual moving units. These stations are linked by inductive radio. The ground station is used by the operator(s) to input the operating schedule and the operational conditions for the coke machines, and it automatically compiles the instructions for charging and discharging ovens. The data for these instructions are then trans-

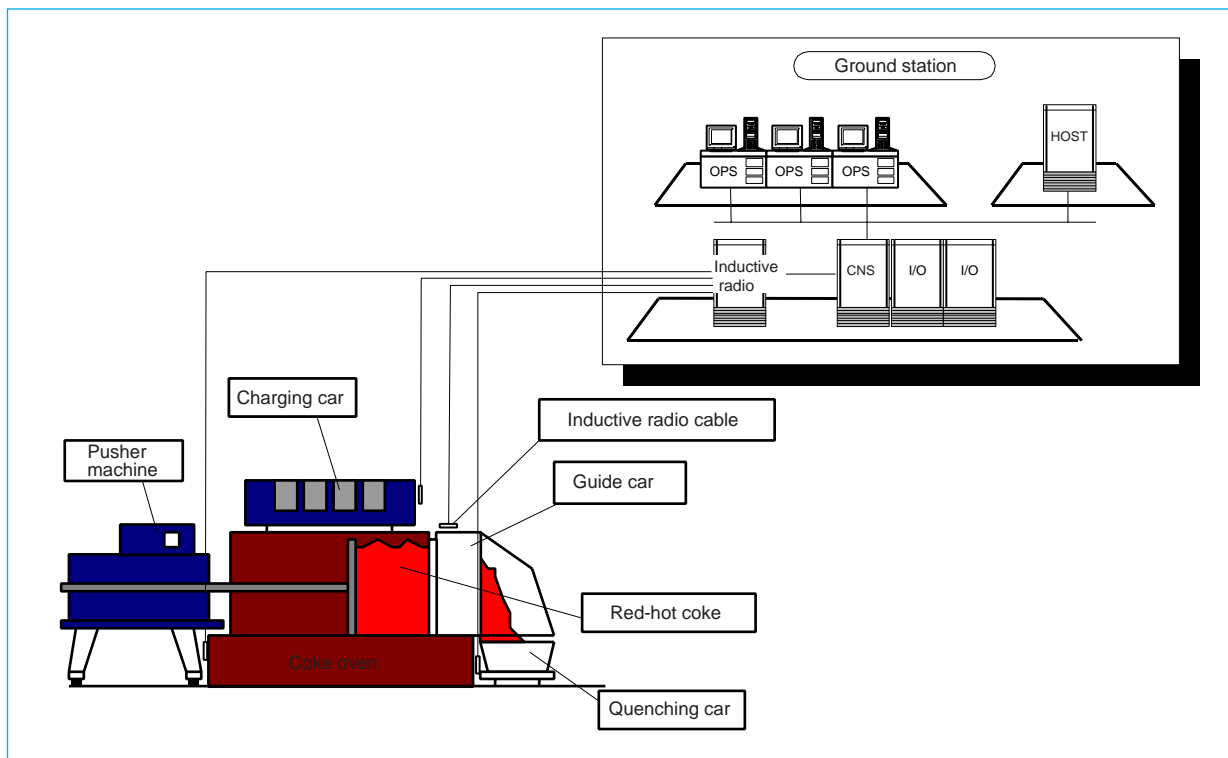

Fig. 1 Configuration of a system for automating coke machines

\*Naokazu Watanabe and Takao Muranaka are with the Energy & Industrial System Center.



mitted to the on-board stations via the datapath formed by inductive radio links. The structure of an on-board station is as shown in Fig. 2. The station follows the instructions issued by the ground station, automatically driving and controlling the various operational devices mounted on it.

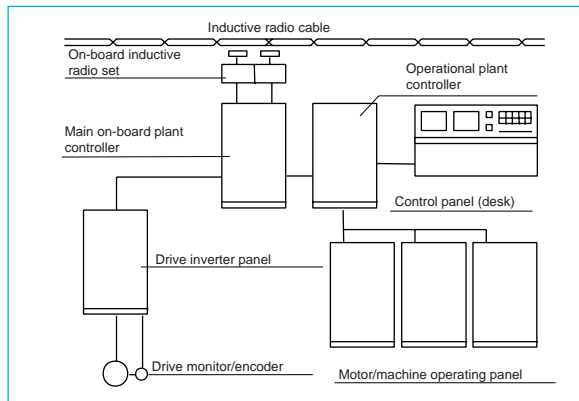

Fig. 2 On-board system configuration

### Achieving the Necessary Stopping Accuracy

THE HIGH-PRECISION POSITION DETECTOR SYSTEM. An accuracy of  $\pm 10\text{mm}$  in targeting "stop" positions is essential for unattended coking operations and, at the same time, the position detector system must be able to withstand the harsh operating environment. The corporation's completed system meets these conditions by adopting inductive radio with absolute position functions and combining it with a follower-wheel position detector. The inductive radio system uses a number of twisted-pair cables layed to form inductive paths. While handling communications between ground and on-board stations, these also establish positional information at 10mm intervals. The high-precision position detector system combines this absolute positional information from the inductive radio signals with the information on movement generated by the position detector and its follower wheel. This combination makes possible the detection of positional information with an accuracy of  $\pm 1\text{mm}$ .

MEASURES TO MINIMIZE CONTROL ERRORS. The main causes of discrepancies in the positions at which the equipment stops are variations in the speed at which positional control comes into effect, uneven brake torques, gradients and deformations in the rails on which the equipment runs, and changes caused by the passage of time or the weather (particularly by the influence of wind). Specific measures must be taken to eliminate each of these influences.

First, there are variations in the speed at which positional control comes into effect. The final stopping position of the equipment is determined by applying the last stage of control to bring it to rest from the slow, fixed "creep" speed at which it travels immediately before stopping. To reduce variations in this creep speed to the minimum, the corporation adopted vector-type inverter control for this motion, linking the inverter and the control system by digital transmission over optical fibers to increase the precision of control.

Next, the effect of uneven brake torques on deviations in stopping position can be reduced by minimizing the creep speed at which control comes into effect. This led to the adoption of an extremely low creep speed.

The third measure reflects the fact that rail gradients and deformations arise at the points where the rail ties secure them in place. Here, separate control parameters are established for each stopping position so that control can reflect the rail conditions at those positions.

Finally, there is the influence of the passage of time and of the weather (particularly wind effects). These are continually changing and very difficult to predict, so we introduced a learning function based on the actual positioning results. This learning function automatically introduces corrective factors to the control parameters based on errors in the stopping position. These parameters are applied individually for each stopping position and for approaches from either direction.

### Reducing the Operating Cycle Time

The first measure to reduce cycle times was to introduce a function that optimizes the accel-

eration, deceleration and fixed speeds so as to minimize the time taken to arrive at each stopping point.

This was followed by an analysis of the most efficient operating patterns for any given series of operations and perfecting a system of interlocks that enables waiting times between operations to be kept to the minimum.

Further, comprehensive means of identifying the causes of any fault that occurs and of giving guidance on how each fault should be eliminated have been provided to reduce the time taken to clear faults and restart operations.

### **Achieving Operational Safety**

Safety measures include measures to prevent collisions and runaway operations.

The anti-collision function provided operates by calculating the operational areas of all moving equipment from their current positions and the positions to which they are moving, and devising running patterns that avoid mutual interference between these areas, so avoiding collisions. Additionally, a function has been provided that calculates the actual separations between the various items of moving equipment from their positions and speeds and the distances within which they can be brought to a halt. When it judges that they are getting too close, it forces a reduction in speed or even stops the movement.

Hardware sensors are also provided to prevent collisions. Sensors on each item of equipment detect when close approaches require an emergency stop. Circularly polarized microwave sensors were selected in view of the harsh operating environment and the need to prevent misoperation.

Other safety measures include the ability to establish "no-go" areas that must not be entered by the equipment while servicing or other work is in progress. This can be done both by delineating the areas on the ground-station CRT and by affixing limit switches at the edges of these areas. Speed limits can also be imposed within each of the operational areas, and the system includes functions monitoring runaway conditions, etc.

Systems for automating coking operations are now, after intensive research and extensive evaluation, approaching actual implementation. However, much of the coking being done in Japan uses equipment that is nearly 20 years old, and new requirements are arising for measures to inhibit the ageing process, extend their useful working life, and develop other useful technologies. Mitsubishi Electric is committed to meeting these growing needs, and is confident that the corporation's sensing and other technologies developed for systems to automate coke machines will play a key role in doing so. □

# Electrical Equipment for Hot-Rolling Mills

by Ken Okamoto and Yoshiaki Nakagawa\*

Hot-rolling mills form one of the most important lines in the steel industry, and require advanced control systems. Mitsubishi Electric Corporation has extensive experience in equipping new hot-rolling mills and modernizing existing ones, and has earned an enviable reputation for the very smooth startup of each such line.

This article discusses the features and benefits of the latest electronic control equipment from the corporation and their impact on improvements in quality control.

## Drive Systems

Gate-turnoff thyristor (GTO) inverters are commonly used as the main drive system in hot-rolling mills. Mitsubishi Electric released its improved second-generation GTO inverter, the MELVEC3000N, to market in 1998, and in 1999 began shipments of its third-generation GTO inverter, the MELVEC-3000A. There have also been improvements in the IGBT inverter, which is used in small and medium-sized auxiliary drive systems, providing both a more compact size and improved performance. The gate commutated turn-off thyristor (GCT) inverter, a GTO inverter with even higher levels of reliability and efficiency, is also ready for use in the field.

## The Structure of the Control System<sup>[1]</sup>

Fig. 1 shows an example of the control-system architecture in the latest hot-rolling mill control systems. This system architecture became possible thanks to both recent advances in general technologies and the corporation's rich experience. The system features increased maintainability and expandibility in compliance with international industrial standards. An explanation of the features of the control system follows.

## Open Information/Control Network

System control uses an open network based on a 100Mbps Ethernet,<sup>[2]</sup> making it easier to provide multiple vendor systems.

The TCIP/IP (Transmission Control Protocol/Internet Protocol) communications protocols are used to ensure easy connectivity with common

devices. Additionally, the use of the simple network management protocol (SNMP) makes it possible to monitor and manage the entire network, including the switching hubs. Thus, the latest IT technologies are used to create an integrated structure in the large-scale multi-vendor systems found in hot-rolling mills.

## The Next-Generation MELPLAC2000

International standards and *de facto* standards such as the PC architecture and the compact-peripheral component interconnect (PCI) standards are used throughout the system.

High-speed processors and dedicated processors perform high-speed operations with bit operations at 0.09( $\mu$ s) and abundant step capacity (96kstep).

The multiprocessor architecture (with a maximum of four CPUs) allows for optimal processing load distribution at higher speeds while allowing expandibility by the addition of CPU cards. The architecture also makes it possible to build up the structure of the hot-rolling mill control system using general-purpose sequencers.

## The OPS-2000 Human Machine Interface

The human-machine interface (HMI) uses a client-server approach enabling the integration of all the EIC screens in an open system compatible with Active-X and with object linking and embedding for process control (OPC). This makes it easier to create a single-window system consisting of multimedia systems, various computers and PLCs, including non-Mitsubishi Electric equipment. This technology can be used for unification of the pulpit in hot-rolling mills.

## The Integrated Engineering Environment

The system provides an integrated engineering tool that uses object-oriented databases. This tool provides a unified engineering environment for drives, PIOs, controllers, HMIs, MELSECs, etc. This system supports IEC-61131-3-based language, which is taken as the international standard. Hierarchical functions and block functions contribute to the standardization of application software. Engineering in large-scale hot-rolling

\*Ken Okamoto & Yoshiaki Nakagawa are with the Energy & Industrial Systems Center.

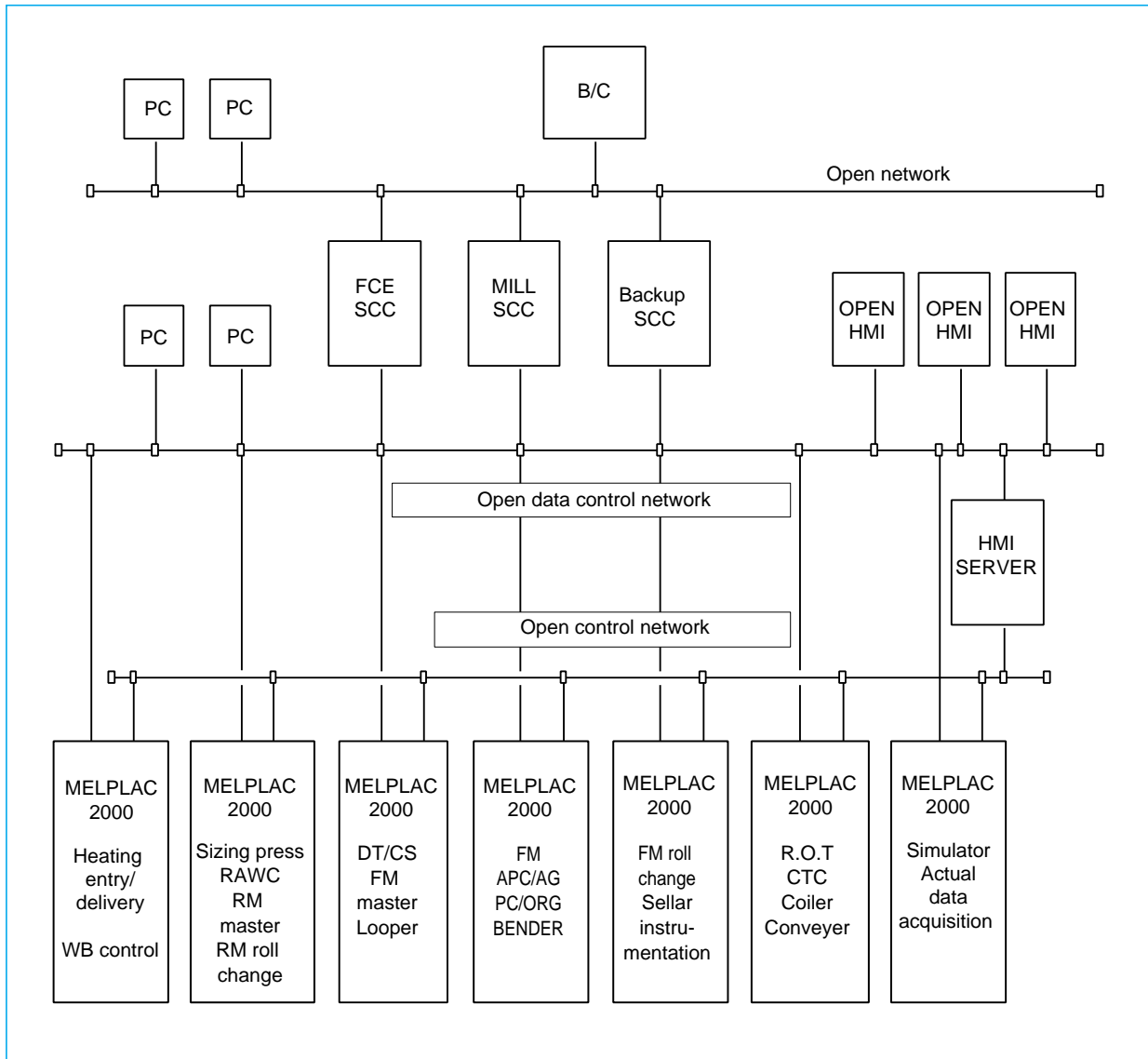

Fig. 1 A typical control system configuration for a hot-rolling mill

mills is supported in the Windows<sup>[3]</sup> environment using a client-server structure.

**The Process I/O System**

The control system is able to connect to existing process I/Os and open field networks.

PROCESS I/O SYSTEMS. These use CC-LINK, an open field network, to enable a distributed PIO system where the functional inputs and outputs (such as process I/Os and operator units on the

workfloor) can be distributed in the work area.

THE DRIVE INTERFACE. Profibus is used to provide open connections with the drive system.

**Hot-Rolling Quality Control<sup>[1]</sup>**

The corporation is one of the few electrical manufacturers that has a full line of quality-control tools such as setup models and dynamic control for the entire process from furnace, through roughing mill, finishing mill and

coilers of the hot-rolling mill.

In recent years, as the needs for ever-higher product quality, process automation and stable operation have grown, the corporation has established more sophisticated systems, as follows.

**HIGHER PRODUCT QUALITY.** For example, the target values for thickness deviation have decreased from 50 microns to 30.

Rather than relying on interventions and assistance by operators, this system simultaneously provides both stabilized operations and built-in quality while minimizing manufacturing costs through total automation and labor rationalization. In particular, in the finishing mill (which requires the greatest number of workers), this equipment has achieved “no-touch” (no-intervention) operations so that the finishing mill can be run by a single worker. At the same time, the system achieves stable threading control and improved thickness and width accuracy.

**Quality Control Application Technologies**

The mill-speed response in the speed-control system has been improved by applying an AC motor and GTO/GCT drive system for the main motor. At the same time, the looper control response and control capabilities have been improved through reducing the looper inertia, by the use of ASR looper control, and by applying multivariable control. These improvements have enabled fast recovery from excessive tension or strip loops when threading, and improved stability of mass-flow balance control and tension control along the entire length of the strip

New functions are provided in the automatic gauge controls (AGCs) such as absolute AGC applied to the entire length/dynamic setup and feed-forward AGCs (FF-AGCs), providing improved control accuracy.

In the setup model, the development of a speed-balance learning function has resulted in improvements in set speed balance at the top end of the strip, where the degree of mass unbalance is learned from the preceding strip and

the following strip. Additionally, the roll-gap setting accuracy has been improved through an adaptive function that uses an intermediate stand-thickness gauge.

**The Results of Quality Control**

“NO TOUCH” ROLLING OPERATIONS. Figs. 2 and 3 show the looper angle charts before and after modernization. As a result of improving the mass-flow balance along the entire length of the strip, and as a result of the stability (of the looper angle), the speed intervention ratio was reduced dramatically to 4.6% of what it was before the modernization. Additionally, improvements in the thickness control system completely eliminated rolling-gap interventions. The result of these improvements is that the entire finishing-line mill can be run by a single operator.

IMPROVEMENTS IN THICKNESS AND WIDTH QUALITY. This system has improved AGC gain through improving the threading stability. When combined with the effects of the new functions and of improvements in the setup,

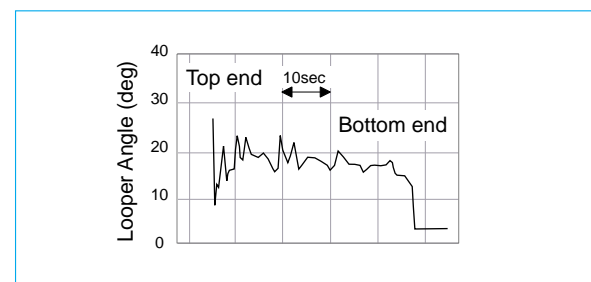

Fig. 2 Looper angle (before modernization)

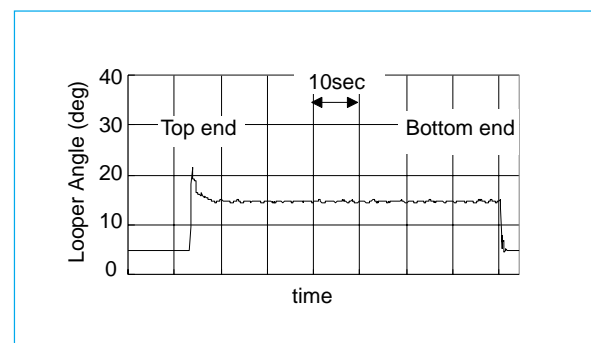

Fig. 3 Looper angle (after modernization)

these improvements have achieved a high degree of thickness accuracy. The plate thickness accuracy after the modernization improved by 2.7% (within a 30-micron tolerance throughout the total length of the strip). Additionally, problems with top-end narrow width were resolved, resulting in a large improvement in product quality.

**LABOR RATIONALIZATION.** In the finishing line, the ability to run the line by a single operator has made possible integrated operation of the roughing mill, the finishing mill, and the coiling line at an integrated pulpit, making it possible to reduce the labor force.

**New Technologies**

Along with improving the level of quality and accuracy of thickness, width, temperature, and shape (which conventionally have been detected by sensors), the corporation has developed and applied new technologies and new controls focusing on instabilities in the hot-rolling process such as pinching, walking, and threadability, where sensing is difficult and complex control is required.

**NEW LOOPER CONTROLS.** ASR multivariable looper control, provided as a standard function in recent years, has lead to a dramatic improvement in threading stability in the finishing line, contributing to improvements in thickness accuracy and in labor rationalization.

This new looper control, in the same style of development, has resulted in further improve-

ments in robustness, in tension control performance, and in the ease of designing control parameters. (See Fig. 4.)

**TOP-END TENSION CONTROL.** Although conventionally there has been no dynamic control in the finishing line during the period from when the top end of the strip has entered the rolls to when the looper control starts to function, now both mass-flow balance and tension is controlled for this period. This makes it possible to improve the top-end threading stability and the top-end gauge accuracy.

**ANALYSIS/DIAGNOSTIC SUPPORT SYSTEMS.**<sup>[2,3]</sup>

Analysis/diagnostic support systems include data-collection functions that collect data such as product information setting parameters, quality data, control data, and so forth. There is also a database function that stores and controls this data and that supports classification of phenomena and graphical display of the data, and regression/simulation functions for analyzing the rolling phenomena. These are used as engineering support/adjustment tools when tuning the system. The addition of diagnostic functions allows the system to be used as an operation support system/diagnostic system for analyzing and diagnosing a rolling process.

Recent advances in hot-rolling mill technologies and their benefits have been described above. Based on the experience and technological capabilities of Mitsubishi Electric in this field, the corporation has focused on the global movement towards open systems, and is striving to develop new technologies and new systems, cooperating with users to create the most advanced hot-rolling mill systems. □

**References**

1. Kazunobi Takami, Yoshiaki Nakagawa: Advanced Electrical Equipment for Hot-Rolling Mills, ADVANCE 79, JUN 1997, 2 - 4 (1997)
2. Naoki Shimoda, Yoshinori Wakamiya: A Control Model Analysis Support System for Steel Mills, ADVANCE 79, JUN 1997 18 - 20 (1997)
3. Isoko Nitta, Yoshinori Wakamiya: The Diagnostic System For Automatic Gauge Control in Hot Strip Mill, IFAC MMM '98 (1998)

**Notes**

1. iFIX is a registered trademark of Intellution, Inc. in the United States.
2. Ethernet is a trademark of Xerox Corp. in the United States.
3. Windows is a trademark of Microsoft Corp. in the United States.

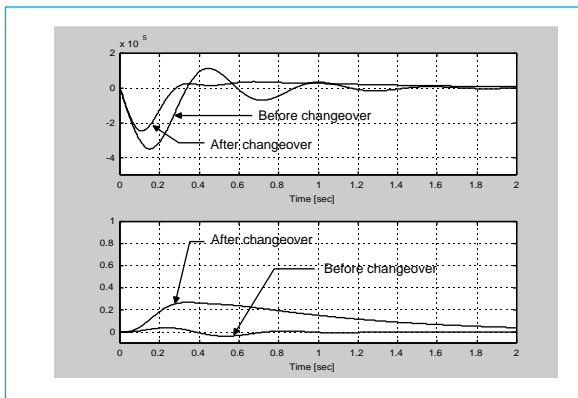

Fig. 4 New looper control (simulation results)

# Controlling Quality in Steel Processing Lines

by Nobuya Yamanaka and Naohiro Kubo\*

The move towards higher value-added products in recent years means that steel processing lines are required to operate at high speed and with high precision, creating products that satisfy ever stricter standards for material quality and shape (dimensions). In meeting these requirements, Mitsubishi Electric has earned a valuable reputation by supplying highly reliable control systems that employ advanced quality control technology. The article introduces the quality control elements of these production control systems.

## Quality Control in Steel Processing Plants

In tandem cold mills, it is vitally important that the weld points (where the strips are joined together) should pass through the mill without causing line stoppages or affecting the stability of line running whatever the rolling conditions

they encounter—whether at high, steady-state speeds, speeding up, or slowing down—so that the necessary qualities of strip thickness and shape can be maintained.

The corporation has developed and now supplies integrated quality control systems for tandem cold mills that cover all operations from dynamic control to setup control, see Fig. 1.

An outline follows of the technologies involved in setup, strip thickness and dimensional control, and the necessary engineering environment.

## Setup Control

In setup control, the model parameters for dynamic control are calculated and set, and the rolling schedule drawn up for the required strip thickness, speed and shape according to the models for rolling loads, shape and setup.

Consistent, high quality production requires

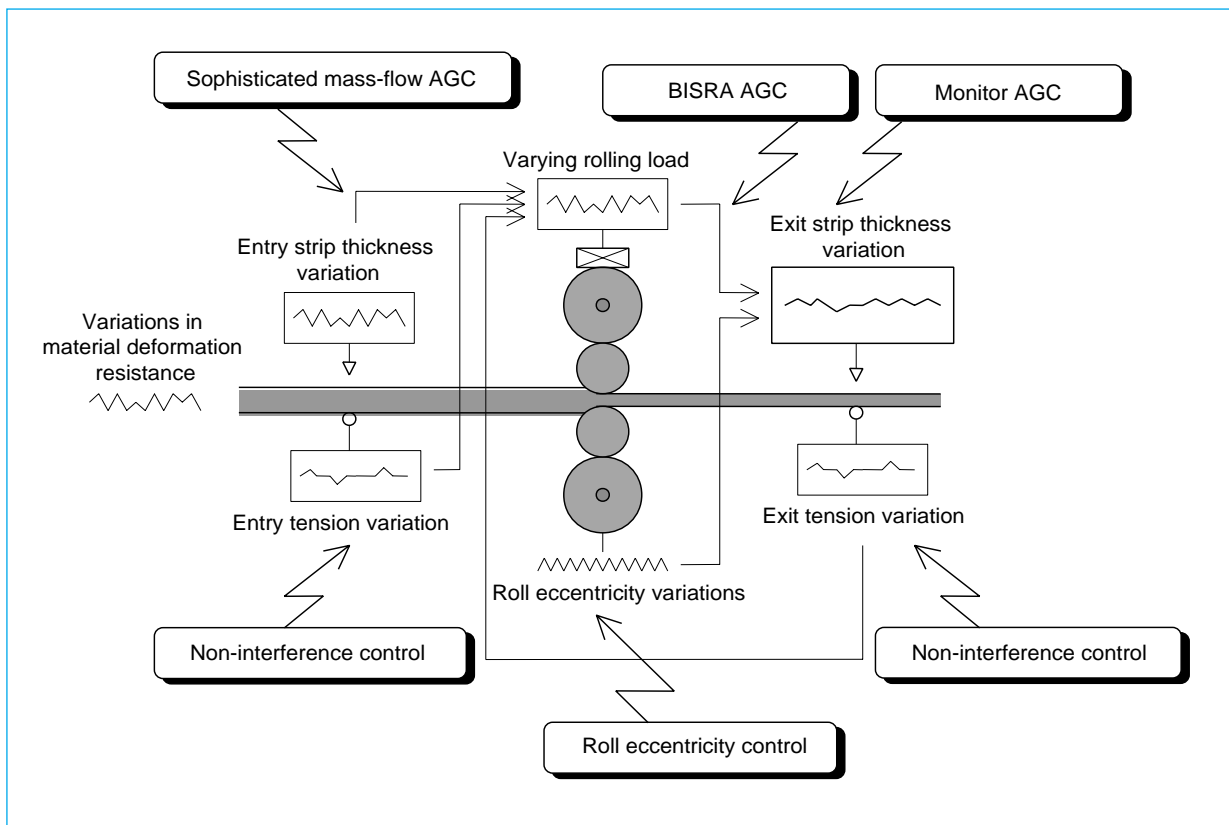

Fig. 1 A cold rolling AGC system.

\*Nobuya Yamanaka and Naohiro Kuba are with the Energy & Industrial Systems Center

a detailed optimum rolling schedule that covers everything from the initial slow-speed rolling to steady-state high-speed rolling, and the speeding up and slowing down that precede and follow it, and other operations at non-standard rolling forces, as when the weld point (the joint between two strips) passes through. There are several distinctive technologies used in achieving this.

**OPTIMUM-DISTRIBUTION SCHEDULE CALCULATION.** A schedule is prepared that satisfies the requirements of, and limitations on, the distribution of power, rolling forces, push-up forces, product quality, ease of operation, etc.

**SETUP CALCULATION FOR HIGH-SPEED ROLLING.** The setup calculations for steady-state high-speed operations are performed so as not to interfere with the planned path schedule for the initial slow-speed start. This ensures that the path schedule is maintained over the entire length of the strip, stabilizing operations.

**DYNAMIC SETUP (DSU).** Automatic flying gauge control is used to reduce the defective area at the head of the strip following a weld or a shear operation. Deviations in strip thickness at the head of the next strip can be improved by reset-

ting the roll gap based on the actual tensions in the preceding stand and the actual thicknesses at the entrance to the following stand.

**Automatic Gauge Control (AGC)**

In tandem cold mills, strip thickness is influenced by the roll gap and the tension within stands, and the extent of this influence is different for the preceding and following stands. Again, strip tension and thickness interfere with one another in complex ways via changes in the roll gap and the rolling speed.

The corporation's AGC system takes account of these process characteristics in using the following distribution and allocation of control functions, see Fig. 1 and 2.

**HIGH-SPEED MASS-FLOW AGC.** This uses strip thickness gauges and speeds for all stands, and uses controls strip thickness by tension or roll gap.

**NON-INTERFERENCE CONTROL.** This controls the changes in strip thickness caused by changes in strip tension.

**SELECTING THE OPTIMUM CONTROL MODE FOR AGC.** This selects the appropriate actuator (tension or roll gap) on the basis of the calculated

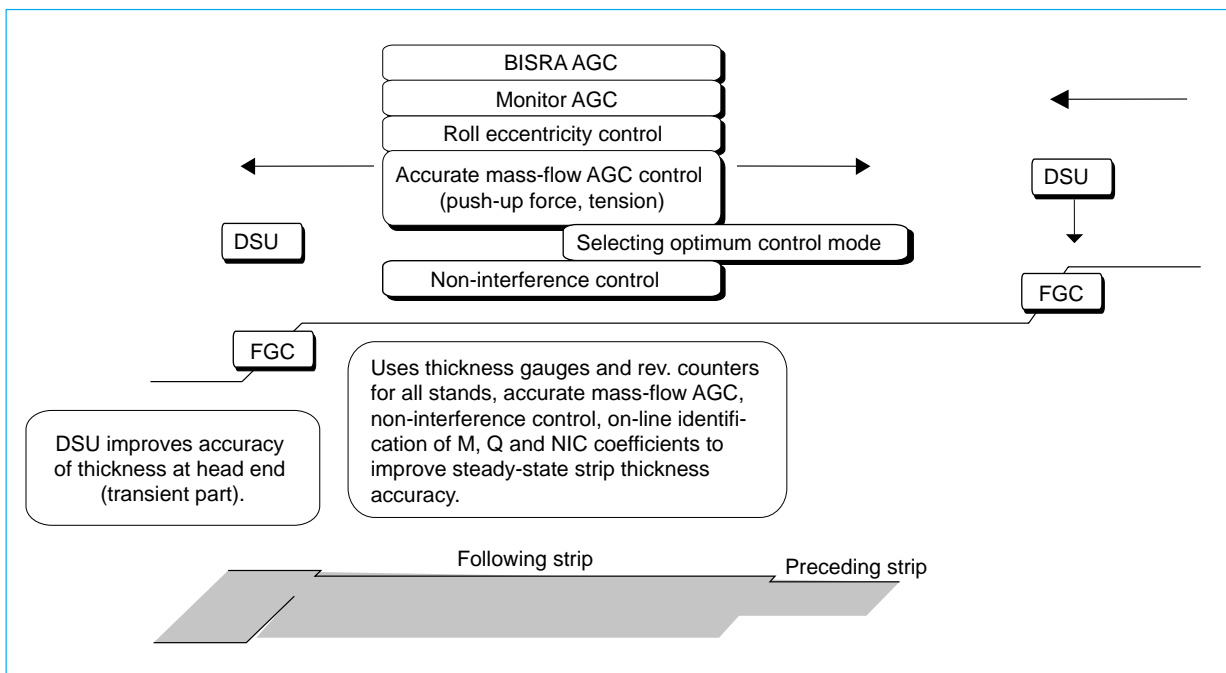

Fig. 2 AGC control time chart



effective parameters for the corresponding schedule and automatically applies the optimum AGC mode.

**AUTOMATIC FLATNESS CONTROL (AFC).** Improvements in the shape of cold rolled sheet steel (the differential distribution of strain across the width) is not only important for higher product quality but also vital for the smooth and stable running of the line for the next process and the quality obtainable from it. The shaping of cold rolled sheet steel follows complex patterns, and the important factors are accurate detection of the actual shape, accurate modeling, and the optimum control of the few actuator variables available.

The corporation has adopted a proprietary method of shape detection, and has configured a powerful shape-control system based upon this accurate shape detection, see Fig. 3.

The shape-recognition system uses orthonormal functions to develop projections in six dimensions; the use of four- and six-dimensional control gives sophisticated implementation of

shapes; and non-interference AGC eliminates interference between shape control and thickness control.

**THE ENGINEERING SUPPORT AND DEVELOPMENT ENVIRONMENT.** This was configured to provide tools for the analysis of rolling phenomena in actual rolling mills, for adjusting control loop gains, and other support tools including those for developing algorithms.

These tools are already making significant contributions to the rapid improvement of product quality in actual plants, and in developing sophisticated quality controls. They include a rolling mill model simulator that identifies model parameters and simulates setup calculations and model calculations. There is also a dynamic control simulator that provides for the simulation of AGC, flying gauge control (FGC) and tension control.

**TENSION CONTROL OF PROCESSING LINE .** In recent years, with increasing demand for automobiles, home electrical goods and canned drinks,

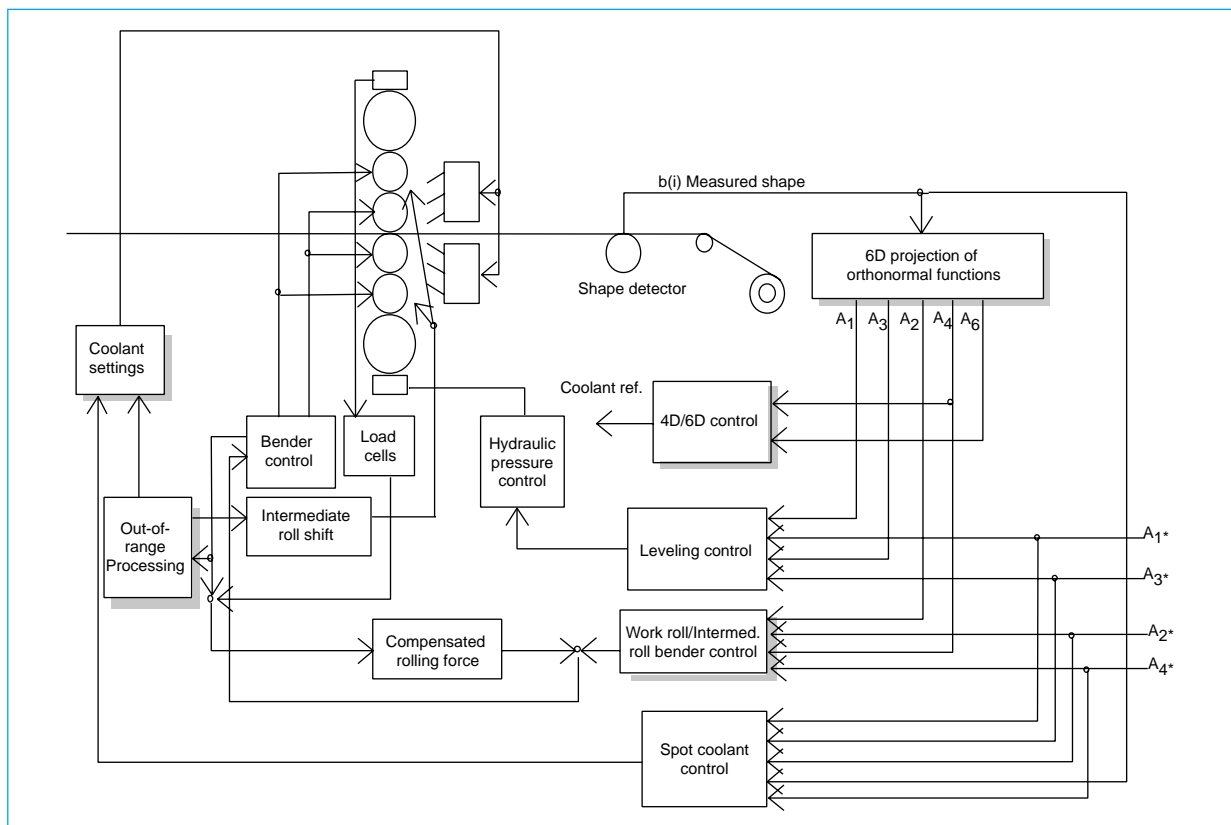

Fig. 3 AFC System.

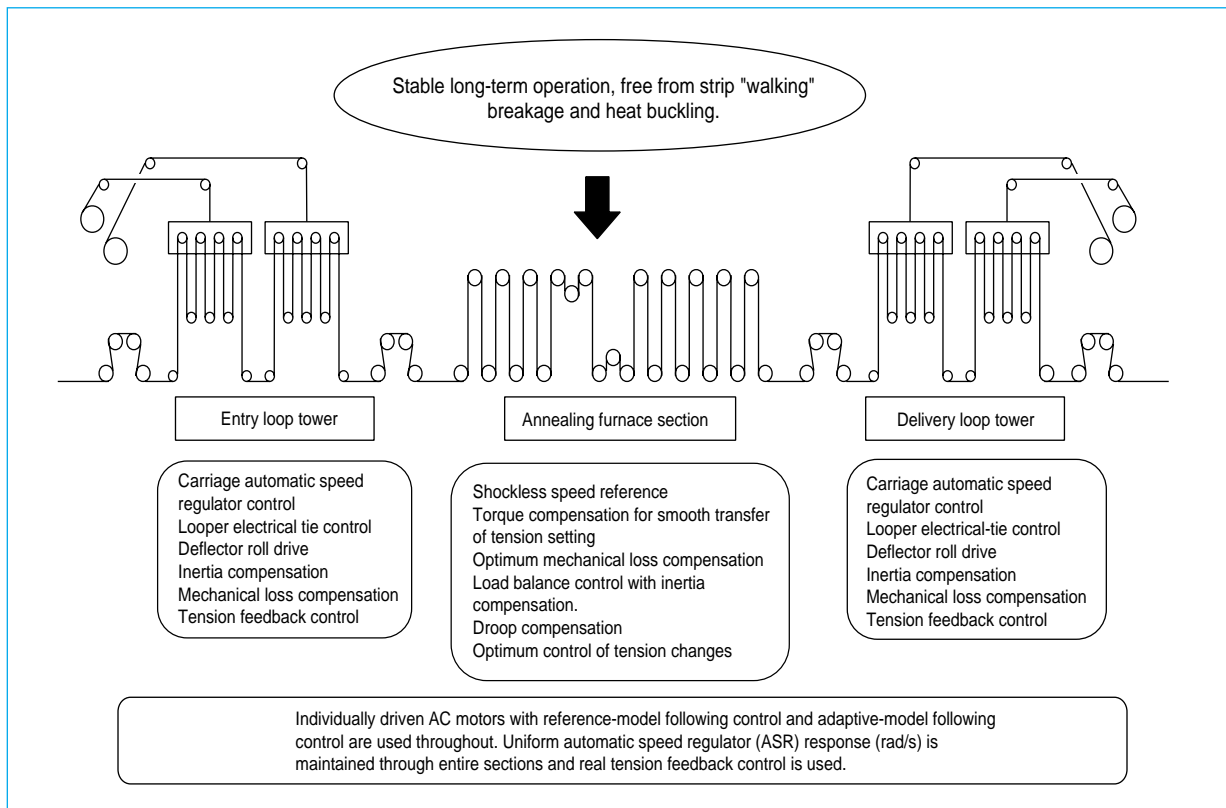

Fig. 4 Strip control functions.

of the very thin strip and high speeds of lines running under low tensions. The corporation has achieved the necessary sophisticated tension control technology for such continuous annealing lines handling thin strip at high speeds. It has the following special characteristics.

Fluctuations in strip tension arise from differences in the speeds of adjacent rolls. These, in turn, arise from:

1. Differences in the rapidity of responses of the different rolls when changing speeds;
2. Movements in the entry and delivery loopers when changing speeds of entry and delivery sections;
3. Aerodynamic or hydrodynamic resistance caused by air, water, etc.
4. Mechanical losses in the drive system; and
5. Bending losses in the strip.

To suppress fluctuations in tension, each roll must rotate at the same speed, and the accelerative response  $\omega_c$  must be improved. However, the helper rollers within the furnace have much larger inertias than motors, and it is therefore impossible to greatly increase the values of  $\omega_c$ .

Here, improvements were made by the effective adoption of reference-model following control for the inverters. Additionally, other factors were investigated for each roller, taking into consideration its function, and consistency was assured by adopting the appropriate form of control for each one of them. This system is shown in Fig. 4.

Quality control is the heart of the large and complex systems used to control modern cold-rolling mill plants and steel processing plant. A wide range of control technologies and a long track record in the steel industry give Mitsubishi Electric an advantage in serving the need for these increasingly important systems. □

#### Reference

1. S. Takayanagi, S. Hamada: Electrical Equipment for Steel Processing Lines, ADVANCE, 79, No. 6, 5-7 (1997)

# Variable-Speed Drive Systems for Steel Plants

by Hiroyuki Masuda and Masaru Toyoda\*

Since the mid-1990s, the shift to the use of AC voltage inverters in driver equipment in steel mills has expanded to encompass all processes in the steel mills, including the critical hot-rolling equipment. The development of six-inch GTO elements, six-inch GCT elements, and three-level control technology has led to larger inverters with better performance. There have also been advances in low-voltage IGBT inverters and DC Leonard equipment.

## New Drive Equipment (Table 1)

In AC drive equipment, the MELVEC 1200N/NS two-level IGBT inverter is used in mid- and small-capacity auxiliary drive applications, and the MELVEC 2000N three-level IGBT inverter is used in high-capacity auxiliary equipment and in low-capacity main drives. The MELVEC 1200N/NS can house a maximum of 12 inverters in cabinets 600mm wide (with a maximum power of 18kVA), or eight inverters in cabinets 800mm wide (with a maximum power of 75kVA). The MELVEC 2000N is 40% smaller than conventional equipment.

In order to ensure the highest possible performance, all of the IGBT inverters use 32-bit RISC CPUs, allowing excellent controllability while providing a uniform control method. The

MELVEC 3000 series of GTO inverters has been added for high-capacity auxiliary equipment and main drive applications. GCT inverters have also been added to the series.

The new MELNARD CF-TD, CF-RD, and CF-UD Leonard equipment have the same range of application as the earlier equipment, and can be used in applications with capacities ranging from 30kW to 6,673kW. These items of AC/DC drive equipment provide excellent current responsiveness (500rad/sec or more) while providing open Windows<sup>[1]</sup> compatibility, affording a high level of uniformity in control and maintenance functions.

## GTO/GCT Inverters

Mitsubishi Electric Corporation began applying gate turn-off thyristor (GTO) inverters to steel mills in 1993, and began shipping six-inch GTO inverters in 1994. Innovations since that time have increased the level of performance of the product, and voltage inverters containing the six-inch GTO inverters have become the established primary drive equipment in steel mills. The number of units has increased rapidly, with shipments already in excess of 100 sets.

As shown in Fig. 2, the third-generation product, the MELVEC-3000 A, has a 50% smaller

Table 1 Specifications for drive equipment for steel mills

Product category	2-level IGBT inverter	3-level IGBT inverter	3-level GTO/GCT inverter	Thyristor Leonard
Model	MELVEC 1200N/NS	MELVEC 2000N	MELVEC 3000A/C	MELNARD CF-TD/RD/UD
Capacity range (kVA/kW)	4.5~1200	1500~3600	10000/20000	30~6673
Input voltage (V)	300/600	1220	3300/3450	500/770/1220
Output voltage (V)	210/420	840	3600/3950	500/770/1220
Output frequency (Hz)	~90		~60	-
Speed control precision (%)	0.01			
Current control response (rad/s)	500		600	500
Speed control response (rad/s)	60			30
Range of field weakening	1:5			
Torque ripple	0~1	0~0.5		0
Cooling	Forced air		Water	Forced air

\*Hiroyuki Masuda and Masaru Toyoda are with the Energy & Industrial Systems Center.

installed footprint than the earlier model, and is 40% lighter; the efficiency of the equipment has reached the 97% level.

Advances have also been made in the control equipment. Although in the past some 15 circuit boards were required for the controller, this number has been reduced to a total of four boards—two boards for the converter and two for the inverter. This was achieved by the use of surface-mount components, and by using a wider range of ASICs. Reducing the number of boards in the controller has not only resulted in further improvements in reliability levels but also increased maintainability. The field-thyrister rectifiers that are required when performing synchronous motor drive have also been made smaller through the conversion from forced-air cooling to water cooling, where the control unit and field-thyrister rectifiers have been combined into a single cabinet. The use of water cooling in the field-thyrister rectifiers has also reduced the load on the air conditioning in the power room.

The corporation has also successfully completed the commercial release of its gate-commutated turn-off thyrister (GCT) inverter, the MELVEC 3000C, using six-inch GCT (which are an improvement on the GTO).

The GCT inverter eliminates the snubber circuit and the snubber energy regeneration circuitry, thereby reducing the number of parts in the equipment. The effect has been further in-

creases in reliability levels and efficiencies (taking the latter over 98%). The six-inch GCT inverter is used with the controller equipment and the main circuit cabinet of the third-generation GTO inverter (the MELVEC 3000A). Although the main circuit block is different, it is compatible structurally with the other, including the positions of the terminals. This commonization allows the new product to inherit the high reliability levels that have been developed throughout the long history of the GTO inverters. Fig. 1 shows a picture of the MELVEC 3000C.



Fig. 1 The MELVEC-3000 C GCT inverter

Table 2 Improvements in 6-inch GTO/GCT inverter

Product generation	1st-generation GTO	2nd-generation GTO	3rd-generation GTO inverter	GCT
Model	MV-3000	MV-3000N	MV-3000A	MV-3000C
Main circuit cabinet size (H x W x D, mm)	2650 x 9000 x 2000	2650 x 6000 x 2000	2500 x 4800 x 1800	2500 x 4800 x 1800
Control circuit cabinet size	2300 x 800 x 1030	2650 x 1000 x 2000	2500 x 1000 x 1800	2500 x 1000 x 1800
Field exciter cabinet size (cooling)	2300 x 1200 x 1230 (forced air)	Included in control cabinet (water)		
Main control boards	14~15 boards		4 boards	
Efficiency	96%	96%	97%	Over 98%
First shipments	1994	March/1998	March/1999	October/2000

**New Applications for PWM Converters**

There is an increasing number of examples where PWM converters have been used to achieve clean power sources (i.e., power sources with high power factors and low harmonics).

The use of PWM converters in modernization of existing equipment makes it possible to eliminate all or most of the power compensating equipment such as static capacitors, producing a variety of benefits such as smaller footprints, reduced maintenance work, and stabilized system operation. Additionally, because this increases the power factor, the use of PWM converters in modernization can increase the capacity of the motors by about 30% without requiring increased capacity in the power-supply equipment.

PWM converters have the benefit of flexible control of the input power factor, and leading power-factor operation is enabled. The lagging reactive power in the system is absorbed, making it possible to improve the power factor.

PWM converters have inherently very low levels of the low-order harmonics arising in thyristors. Additionally, when multiple PWM converters are used in the same system (such as found in tandem drive mills and twin drive mills), the harmonics can be canceled out by jointly controlling the PWM pulses to reduce the harmonic levels still further.

**New Control Functions**

The application of group control to table motors in rolling equipment has become commonplace. Table drives require a high torque outputs at low speed region. These requirements are fulfilled through the use of a speed sensor-less vector control method. Improvements in the control algorithms in the MELVEC-1200N/NS have led to increases in the number of applications of such units. Fig.2 shows an actual waveform from a case where this group control was used. In typical motors, speed sensors have been used to measure the behavior of the motors. However, acceleration in the electrical current limit status based on accelerative commands is now possible, and the match with the estimated speed has been verified in the various motors.

Sometimes there have been interruptions to operations when thyristor converters and cycloconverters were used, such as when there were commutation faults or blown fuses when

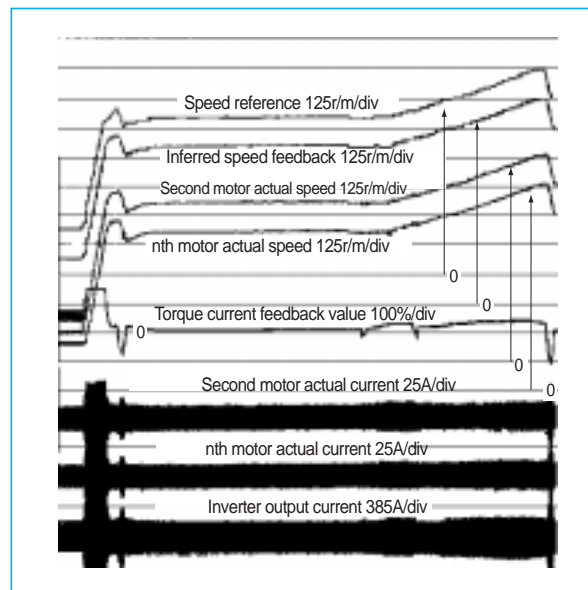

Fig. 2 Measured waveforms during group control

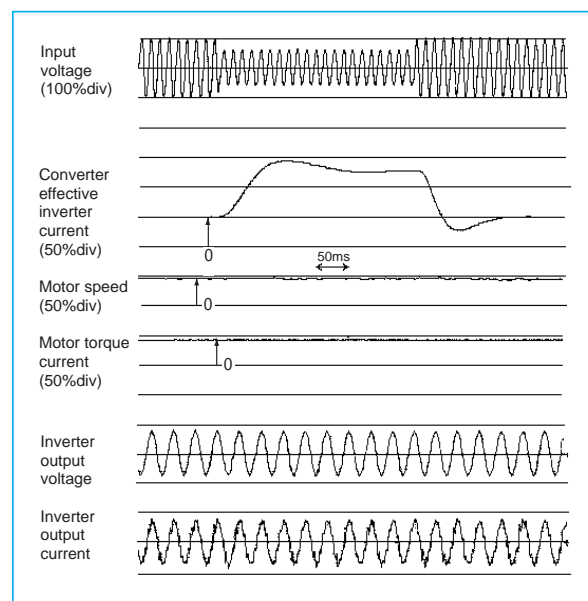

Fig. 3 Instantaneous voltage drop test results

the power supply fell below the rated voltage. Because the PWM converter has an electric current self-turn-off capacity, it has the advantage of allowing continuing operations even when there has been a dip in power-supply voltage.

Fig. 3 shows a chart that was used to confirm continuing operations when there was a simulated voltage dip, indicating that the highly responsive control allowed the continuation of stable operations even given an instantaneous power dip.

Designs have been produced for plants where voltage dips due to lightning activity are common; here, the use of PWM converters in the power supply-side converter equipment with main GTO inverters and auxiliary IGBT inverters will allow continued operation even given 40% voltage dips for 0.1 seconds.

Mitsubishi Electric is proud to have pioneered advances in variable-speed control and power electronics that now serve in many of the most advanced steel-making plants in the world, providing the operators with greater economy, higher and more consistent quality, and reliable operation even in the face of major voltage dips. □

# Computer Systems for Controlling Steel Plants

by Kazuo Sena and Shigehiko Matsuda\*

The iron and steel industry is calling for the creation of open industrial computer systems (ICS), and for systems that are smaller and more easily maintained than the systems of the past. This article describes Mitsubishi Electric Corporation's MR series of control computers for mission-critical applications, and the Mitsubishi Windows<sup>[1]</sup> System for Steel Plants (MWS) series of open-system control computers, describing the features of the systems, configuration concepts, the open software, and the maintenance support functions.

Computer systems used for controlling iron and steel plants focus on appropriate system architectures for each of the respective domains in which the systems are used, and there has been rapid progress in both opening and right-sizing these systems.

Systems have already been configured using this approach in the lower systems in rolling mills, even to the point that future applications to the rolling lines themselves are being considered.

Computer systems for plant control today require more than the already essential real-time response and high reliability; system openness must now be added to the list. In the iron and steel industry, where plant and equipment is aging from long years of use, there is also a particularly insistent call for uninterrupted maintenance.

This article discusses trends in computerized control systems for iron and steel plants, concepts for system configurations, and the features and structures of the MR series and MWS series industrial computer systems.

## Trends in Control Systems in Iron and Steel Plant Controllers: Towards EIC Integration and Total-Information and Control Systems

Conventionally, separate dedicated machines have been used for business computer (B), electricals (E), instrumentation (I), and computers (C), providing rapid execution and high standards of service and availability. On the other hand, the 1990s saw a movement towards EIC integration, allowing an enterprise to pool all of its data. LANs provided the technological underpinning for this movement, and acceptance accelerated as the

technologies became more sophisticated, and the systems were integrated by the creation of common process I/O (PIO) and human-machine interfaces (HMIs: these usually consist of a graphic display device such as a CRT and means of entering control commands). A hierarchy of LANs has also emerged, ranging from the general to the more specialized, and from Ethernet<sup>[2]</sup> to FDDI systems, each with its own specific uses. The data handled is more than just control data, including a variety of operational and processing data, seeking to establish comprehensive systems that embrace both data systems and control systems.

In the future it will be necessary to interconnect a variety of support systems (engineering support, operational support, diagnostic support, maintenance support, software development support, etc.) so as to form a data and control system capable of optimizing manufacturing throughout the plant. Client-server configurations are now being used for the functions. Fig. 1 shows changes in information and control systems over time.

## Computer Automation Systems in Iron- and Steel-Information Control

SYSTEM CONFIGURATION. The above move towards automation implies a variety of constraints that must be addressed when configuring actual systems. The system-configuration concept shown in Fig. 2 makes it possible to select and provide more far-ranging solutions. The system must include structures basic to the entire system, open-system structures positioned as support systems, and the overall system configuration must rigorously implement right sizing.

Mitsubishi Electric, taking advantage of its wealth of experience in factory-control systems, offers the MR series of industrial computers as base systems, and the MWS series of industrial PCs as peripheral and lower-level machines.

## System Configuration Using the MR Series of Industrial Computers

MAINTAINING REAL-TIME RESPONSIVENESS AND OPEN SYSTEMS. The MR series inherits the tried-

\*Kazuo Sena and Shigehiko Matsuda are with the Energy @ Industrial Systems Center

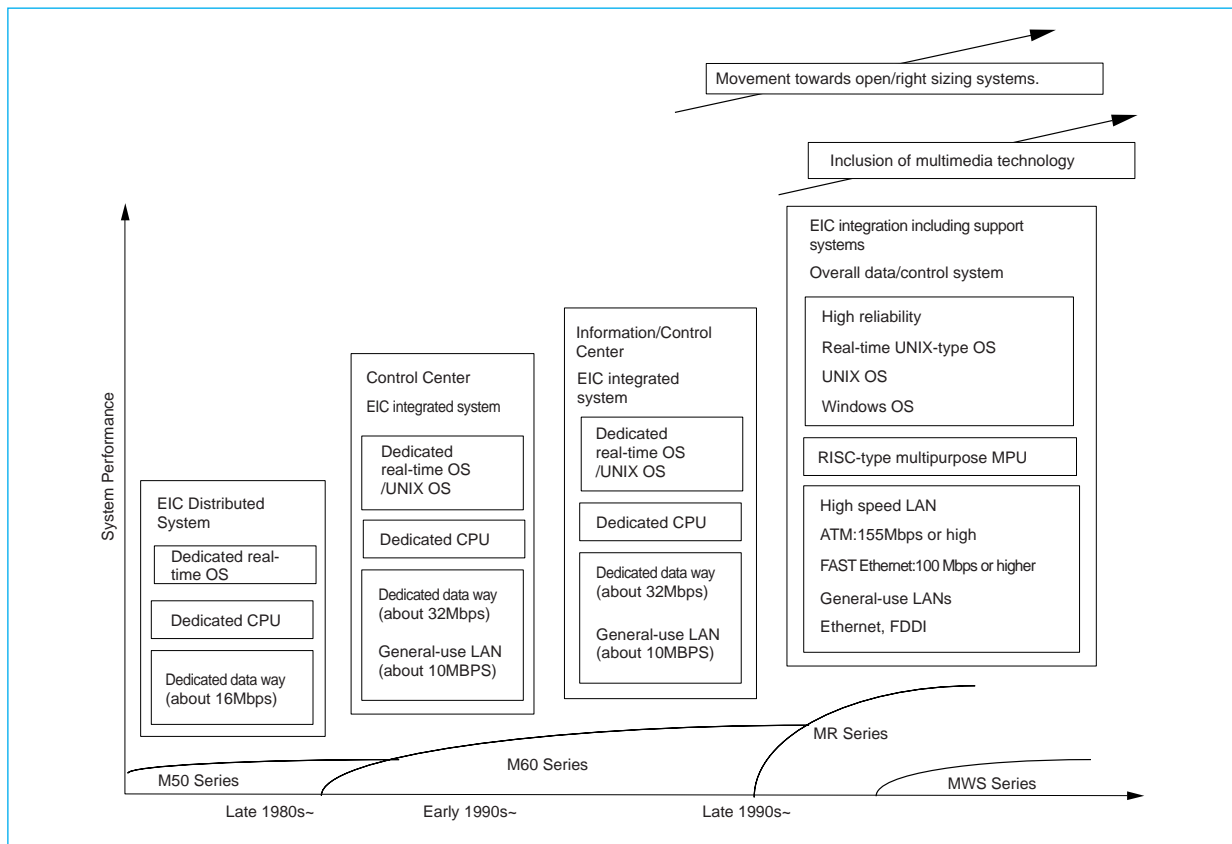

Fig. 1 Changes in information and control systems over time

and-true real-time OS concept, maintaining real-time response and ease of system analysis while adopting POSIX-based real-time UNIX<sup>[3]</sup> to provide superior accessibility in an open system.

**HIGH-SPEED CALCULATIONS.** The highest level of calculation performance is provided through a process computer equipped with leading-edge high-speed RISC processors.

**IMPROVED RELIABILITY (THE RAS FACTOR) AND MAINTAINABILITY.** The system secures high levels of reliability, and ease of continuous operation and maintainability, meeting the requirement that this equipment should run continuously.

**FLEXIBILITY OF SYSTEM CONFIGURATION.** Control systems for iron and steel manufacturing must interconnect with business-computer systems, plant controllers, design systems, and a variety of others. The full set of network functions in the MR Series units can be used in flexibly configuring the required system.

For example, for systems that require a high degree of real-time interactivity, the integrated control bus (MDWS-600S1) can be selected, while in those systems where there is a greater need for the system to be open, Ethernet connections may be selected. Conversely, the FDDI (the Fiber Distributed Data Interface) for control can be selected when both real-time responsiveness and openness are required. Use of the other communications options makes it easy to

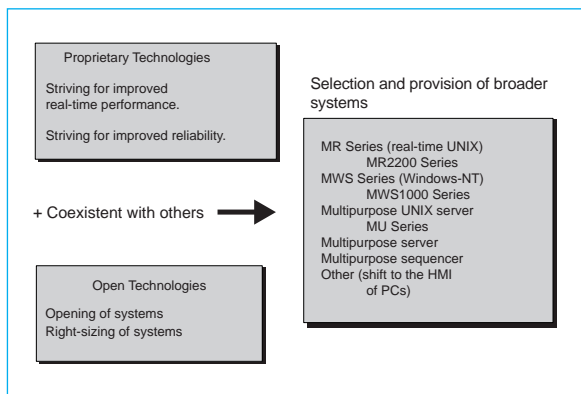

Fig. 2 Approach to industrial computer systems



connect through a communications server, not only to the specialized control devices within the enterprise but also to other, general equipment. An example of a hot-rolling system that uses the FDDI for control is shown in Fig. 3.

**System Architecture Using the MWS Series on an Industrial PC**

The MWS series (the Mitsubishi Windows System for Steel Plants) comprises Windows NT-based<sup>[1]</sup> iron- and steel-manufacturing control computers that support process control in new developments, file systems, PIO drivers and other basic software, while providing an open-system structure with superior cost/performance. When compared with conventional PC systems, the MWS Series systems offer the following benefits:

**ENHANCED RELIABILITY FOR CONTINUOUS OPERATIONS.** RASIS (Reliability Availability Serviceability Integrity Security) and connectivity are the keys, here. Using the industrial standard interface, the MWS Series controllers can be connected to a broad variety of open devices. In addition, the Corporation's proprietary direct-connect PIO and data way can also be used for control.

**IMPROVED MAINTAINABILITY.** This system secures a mean-time-to-maintenance (MTTM) similar to that of conventional industrial computers. Front-panel maintenance makes it easy to replace parts subject to wear (filters, fans, disks, etc.).

**Open-System Software**

The software requirements are for the use of an open operating system (OS) compatible with multiple vendors, responsiveness to cost reductions, and improvements in software productivity.

**OS SELECTION.** The critical requirements of the OS for iron and steel ICS systems are real-time response, high-speed execution, and high reliability and maintainability. There is also the need for open-system architecture to support flexibility in system configuration. The use of open-type UNIX servers is also a possibility based on the growing scope of PC applications and in view of the need for customer maintenance by customers overseas. OS application regions and their changes over time are shown in Fig. 4.

**MIDDLEWARE SELECTION.** With respect to the iron and steel middleware that Mitsubishi Electric has

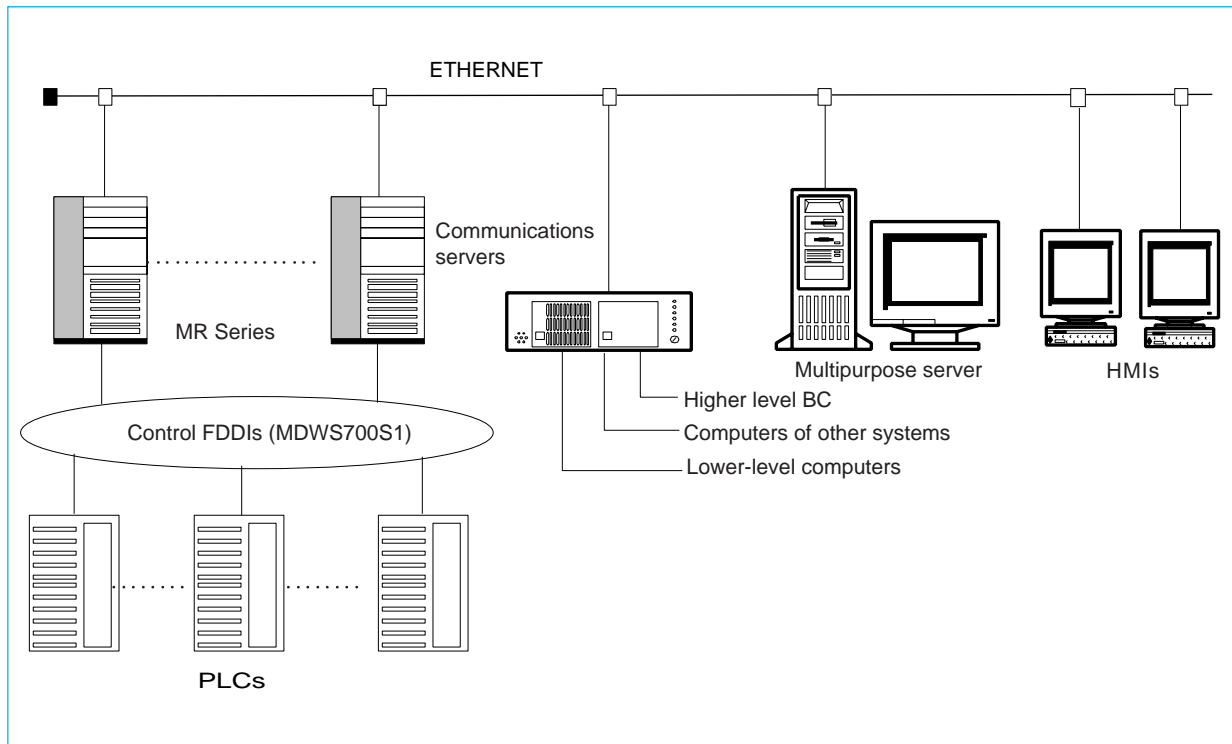

Fig. 3 Typical configuration of a hot-rolling system with FDDI control

Scope of Application	95	96	97	98	99	00	01	02	Features
1 Hot rolling, hot plate, cold rolling, etc.	OS60								Requires large scale and high speed. Real-time characteristics are good.
2 Blast furnace, raw materials, Basic Oxygen furnace, etc.								The number of functions is moderate when performing large-scale data processing. Real-time capability is not particularly good.	
3 Test equipment/peripheral equipment, etc.								Functionality is low and real-time responsiveness is not good.	

Fig. 4 The changing applicability of OS software over time

previously supplied, the corporation has taken several forward-looking initiatives, as described below:

**CUSTOMER SOFTWARE ASSET INHERITANCE.** The conventional APL interface has been adopted, as have the languages (FORTRAN, C), providing continuity with earlier models.

**ELIMINATION OF MODEL DEPENDENCY.** Test efficiency is increased and the number of prototypes required is decreased through the use of the middleware interface (MWI) coefficient, which absorbs differences in the basic middleware (process control vs. file control, etc.) and differences in the OSs used in the respective machines.

**COMPATIBILITY WITH OPEN DEVICES.** The system is compatible with high-end imaging software and with HMIs that are used on the Internet (including Java).

**TRACE FUNCTION.** The system includes a function-level operating history in order to improve the ability to perform analyses when problems

arise.

The middleware software configuration shown in Fig. 5 reflects all the above considerations

**APL SELECTION.** The following methods have been used in order to create standardized products using conventional APLs (which have been oriented towards the engineers). These considerations are illustrated in Fig. 6,

- Simple arithmetical calculation processes are isolated
- Automatic generation of source code from the high level design such as GDFs<sup>[4]</sup>, P-LINK<sup>[5]</sup>, database structures and properties list, alarm lists, etc.
- Automatic generation of specifications for the parts generated automatically above.
- An integrated development environment integrating the above (builder/generator).

**Facilitating Maintenance**

As a system by which to provide support for maintenance rationalization in various iron and steel

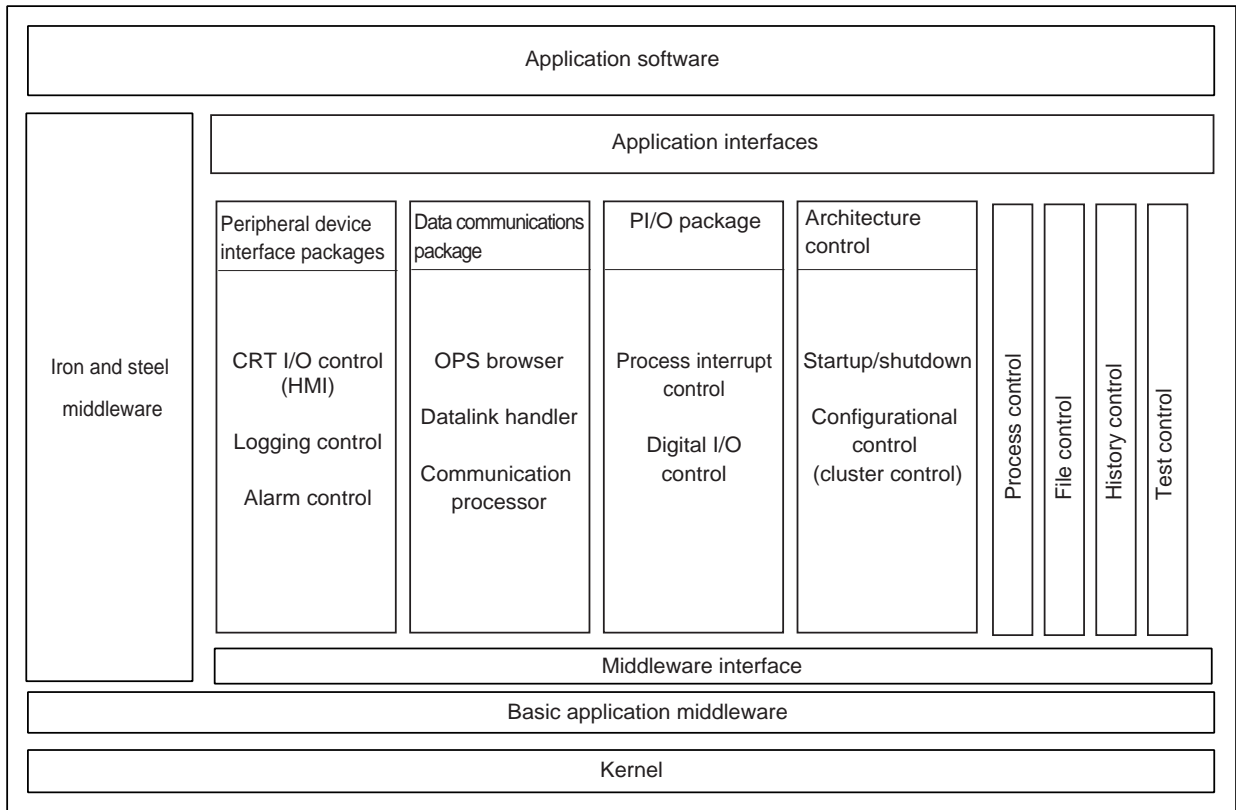

Fig. 5 Configuring middleware software

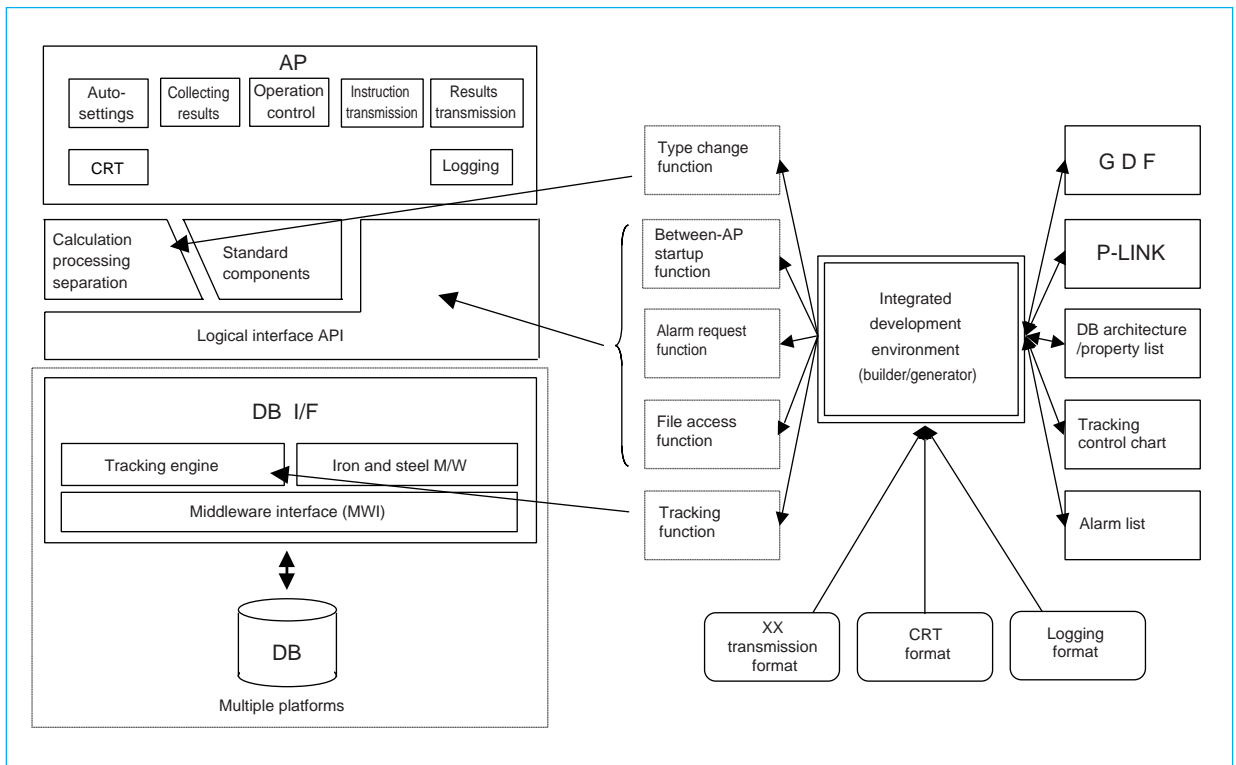

Fig. 6 Creating standardized products using conventional APLs

works in Japan and throughout the world, Mitsubishi Electric is providing remote maintenance support/operational support directly to customers whose computers are connected via a service provider to the Internet or to an intranet.

- Preemptive diagnoses/preventive maintenance are performed.
- When there are failures, the failed devices are identified remotely and support is given to the customer in recovery strategies.
- Spares for equipment identified as malfunctioning are taken to the customer site to speed recovery.
- The operating conditions and efficiency of the plant are monitored remotely in a centralized location.
- Support for mobile functions such as screen displays on mobile equipment or monitoring from other pulpits (control rooms) in the steel mill or from other buildings.
- Support for telecommuting staff operations on holidays and after hours, and remote operation support from the manufacturer when problems arise.

The above functions make it possible to operate a control environment with rapid and comprehensive maintenance using fewer personnel. The benefits described above were derived through the use of the dedicated tools and Java-based monitoring middle-ware.

#### Future Developments

The Mitsubishi Electric industrial computer systems (MELCOM350/MR3000, 2000 Series), as computer systems that combine both real-time control of plants and an open-system orientation, have achieved an enviable track record in a variety of processing industries including iron and steel. The MWS series has also been deployed in a large number of iron and steel mills as a factory automation computer. The combination of these two systems has made it possible to provide both optimal solutions to the diversification of data in control-system configurations for the industrial fields of the future and to create a sophisticated maintenance support environment that incorporates information technology using the web and multimedia. □

#### Notes:

1. "Windows," and "Windows NT" are trademarks of Microsoft Corporation in the United States.
2. "Ethernet" is a trademark of Xerox Corporation in the United States.
3. "UNIX" is a registered trademark in the United States and other countries, licensed by X/Open Co. Ltd.
4. Global Database Flow (GDF): The flow between databases of the various types of events in the data handled by the system.
5. Program Linkage (P-LINK): The links to processing programs for the various types of events.

#### References:

1. Kazuo Sena, Noriyoshi Hiratsuka: An Industrial Computer System for Iron and Steel Plants, ADVANCE, 79, No. 6, 11~14 (1997)
2. Kazuo Sena, Keijiro Takeda: Information System for Iron and Steel Plants, ADVANCE, 82, No. 3, 21~25 (1998)

# Control Systems for Steel Plants

by Yuuji Takahashi and Keiichi Fuse\*

The primary requirements of control systems are that they should provide fast, real-time responses and achieve highly reliable operation. This has previously meant that each manufacturer attempted to use its own proprietary technology to meet these requirements. However, in recent years, an increasingly strong demand for more “open” control systems has been accompanied by general technological advances that make it possible to satisfy these requirements using open technology. Mitsubishi Electric Corporation has developed the new MELPLAC 2000 series of steel-plant control systems by actively adopting international and industry-specific standard technologies. The system configuration is shown in Fig. 1.

## Features of the Controller

MELPLAC 2000 controllers have adopted the

very latest control technologies to achieve highly reliable integrated control, both electrical (E) and instrumentation (I), as follows.

**FASTER AND HIGHER CAPACITY CONTROL.** These improvements to control performance are achieved by combining high-performance processors and dedicated processors to execute arithmetical bit operations in  $0.09\mu\text{s}$ . Plant-oriented language (POL) supports up to 96k electrical control steps and 320 instrument loops can be handled. The adoption of a multiprocessor configuration (supporting a maximum of four CPUs) allows CPU performance to be upgraded by high-speed optimized load distribution.

**STRUCTURED SOFTWARE.** Top-down design and the encapsulation and modularization of software greatly facilitates product design and production.

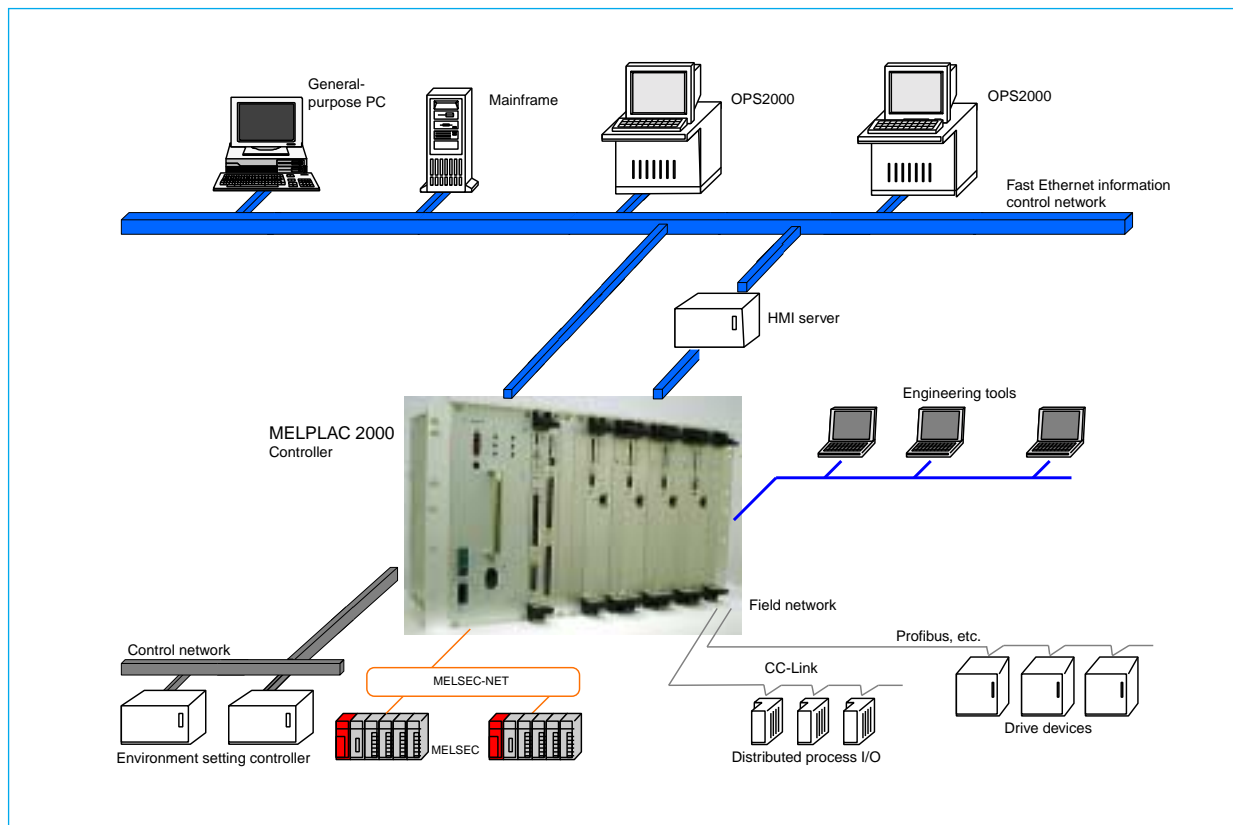

Fig. 1 A MELPLAC 2000 control system

\*Yuuji Takahashi and Keiichi Fuse are with the Energy & Industrial Systems Center.

Online maintenance is possible at the level of the individual software capsule and module.

**HIGH RELIABILITY AND AVAILABILITY.** Extensive self-diagnostic capabilities are provided for each printed-circuit board (or card), and each complete station. Standby redundant CPU operation provides for redundancy.

**EASY MAINTENANCE.** Operation is rendered largely maintenance free by using memory with backup to store information on reliability, availability and serviceability (RAS). Maintenance tools include displays of faulty components throughout the entire control system, including the power supply, and maintenance is possible at the level of individual CPU cards by using the RAS information stored within the cards. What maintenance is needed can also often be performed from remote locations, using public telephone lines, further facilitating procedures.

**Network Features**

MELPLAC 2000 systems are compatible with Ethernet LANs as the information/control network, and communication with general-pur-

pose equipment is facilitated by adopting TCP/IP as the communication protocol. Use of the simple network management protocol (SNMP) makes possible unified management of the entire information/control network including all equipment provided by various vendors (see Table 1). Industry standard field buses (CC-LINK and Profibus) are provided, and connections are possible for a wide variety of field equipment provided by other vendors.

**Features of OPS2000 Servers and Clients**

Operator's Station 2000 (OPS2000) consists of servers responsible for data acquisition and clients that display data tables.

Fig. 2 shows the software configuration. The human-machine interface (HMI) implementa-

Table 1. Information/control network specifications

Network topology	Start	
Transmission medium	Optical fiber (GIMMF625/125μm) Twisted pair (cat.5UTP) etc.	
Physical layer specs.	IEEE802.3u etc.	
Max. bus separation	10Base-T	100m
	10Base-L	2000m
	100Base-TX	100m
	100Base-FL	2000m (full duplex), etc.
Communication protocol	TCP/IP, UDP/IP	
Control protocol	SNMP	

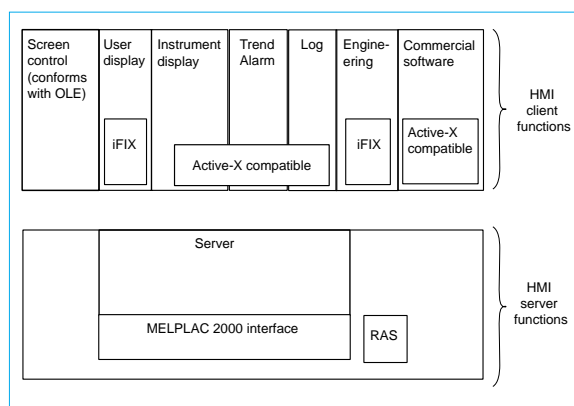

Fig. 2 OPS2000 software configuration

tion features object linking and embedding (OLE), OLE for process control (OPC) and Active-X to interface between client programs. Active-X controls are used for the various screen displays, and the operating environment uses Active-X containers while some of the control data interfaces use OPC to achieve an open HMI offering single-window multi-vendor interface capabilities. Again, the graphical user interface (GUI) uses Intellution's iFIX, which has an established world-wide track record (see Fig. 3). Data acquisition functions are provided on the HMI server side for information exchange with the HMI client.



Fig. 3 A typical OPS2000 screen

**Features of the Engineering Tools**

The engineering environment supports not only the macro control diagram (MCD) language, primarily for electrical control (see Fig. 4), but also the international standard language IEC61131-3 (see Fig. 5), with hardware settings, and a maintenance environment integrated with a Windows environment to form an open environment. From an engineering perspective, an electrical equipment database provides one-source control while high-level languages appropriate to the various objectives are used to describe control regimes, to generate software automatically, to provide for the transfer of information on settings, and for monitoring. In particular, software visualizations, checking functions for logical descriptions, and the automatic assignment of resources are among func-

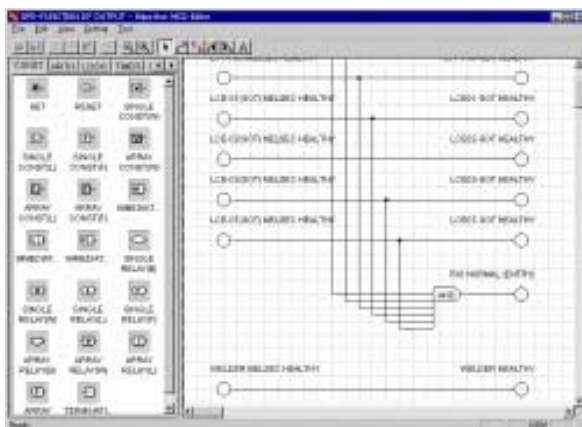

Fig. 4 A typical MCD programming screen

tions supported to improve engineering efficiency. Again, the provision of remote maintenance capabilities enables engineering tools to be used over the LAN or the public telephone network connected to the control system, thus enabling the corporation to support user plant

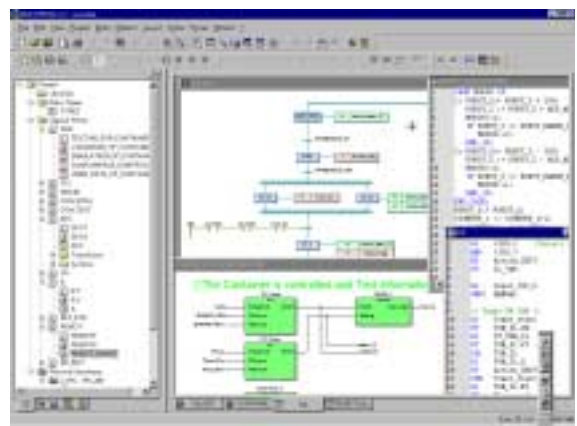

Fig. 5 A programming screen using international standard language

maintenance directly from its maintenance service sites.

While the use of open systems has obvious advantages for the end user, it also imposes new responsibilities on control-system vendors. Mitsubishi Electric now offers a new generation of flexible and cost-effective solutions that use the latest control technology to provide outstanding performance, high reliability, and great ease of maintenance. □

# A Quality Control and Diagnostic System for Hot-Rolling Mills

by Yoshinori Wakamiya and Isoko Nitta\*

Even the most highly automated steel mill requires human operators to supervise its operations. Mitsubishi Electric Corp. has developed the large-capacity data-handling system introduced here to enhance the monitoring and diagnosing of automated control procedures in a hot-strip mill, reducing the operator load while raising production quality.

The system provides continuous online supervision of the control status, notifies the operator of any problems and provides clues regarding their likely cause.

## The Hot-Finishing Process

The finishing-mill and quality-control system in a hot-strip steel plant are outlined in Fig. 1. After a hot strip has been processed in a roughing stand to the nominal required thickness, it passes through a series of finishing stands where it is rolled to its final product thickness. It is then cooled and wrapped onto coils.

Thickness is controlled by a finishing mill setup function (FSU) implemented on a process control computer, and by automatic gauge control (AGC) and looper control (LPC) functions provided on plant controllers. The FSU is used to make initial settings for roll-gap position and the speed at which strips are rolled through the mill (threading speed) to achieve the desired thickness; the AGC controls the precise positioning to maintain that thickness, while the LPC controls the rolling equipment to ensure

uniform tension as the strip passes from stand to stand.

## The Hardware

The hardware making up the diagnostic system is outlined in Fig. 2. The system consists of an online process-control computer and a personal computer connected to it on an Ethernet\* or other LAN.

The diagnostic system relies on a database of product information such as coil number and size, along with actual production values as gathered by the actuators and sensors used for online control. A high-speed LAN transfers the data as needed from large-capacity data files stored in the process control computer to the diagnostic personal computer.

## The Software

The software used for the diagnostic system, shown in Fig. 3, provides functions for monitoring and classifying data and for identifying fault causes.

The data-monitoring and classification system gathers and stores plant data from the plant controllers and process control computer, including initial data settings and sampling results. When these data suggest that a problem has occurred, the system displays the status on the screen. It instructs the operator on measures to be taken and also calls up the system for analyzing the cause of the trouble.

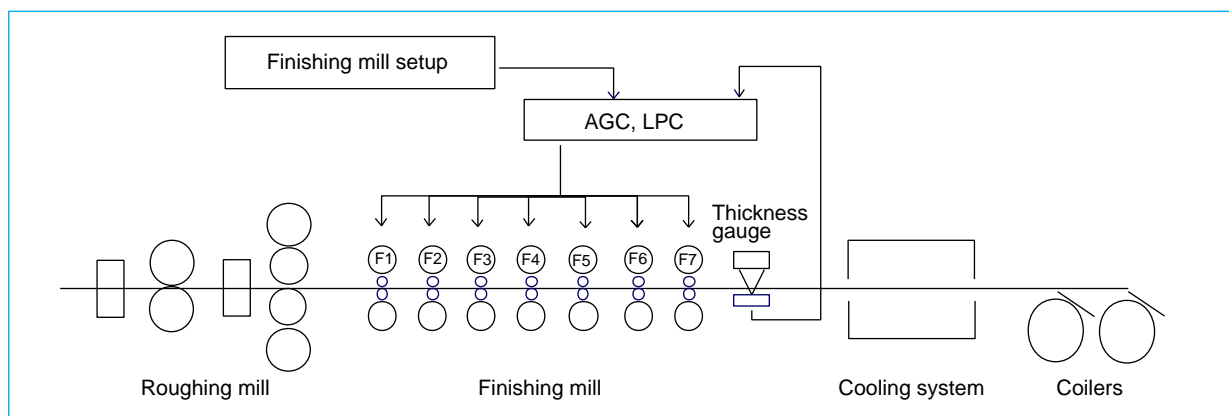

Fig. 1 Finishing mill and quality control system in a hot-rolling factory

\*Yoshinori Wakamiya & Isoko Nitta are with the Energy & Industrial System Center.



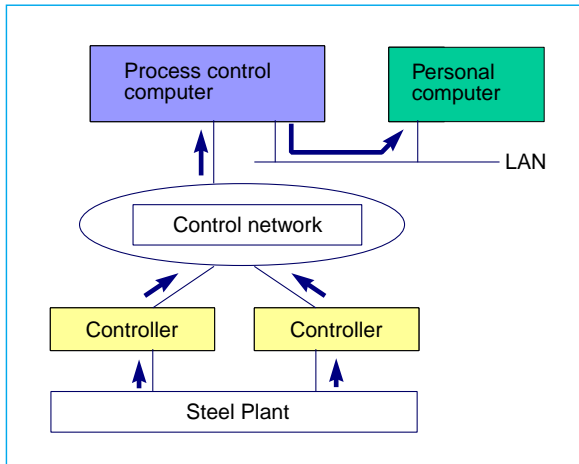

Fig. 2 Hardware configuration

The cause-analysis function is activated only when trouble occurs; it attempts to determine the likely cause of the trouble by applying a diagnostic rule base. It replicates the control status at the time the problem occurred by running a control-model simulation that emulates the online control system. By comparing this result with past observed data, the system can pinpoint where a problem occurred in the control logic.

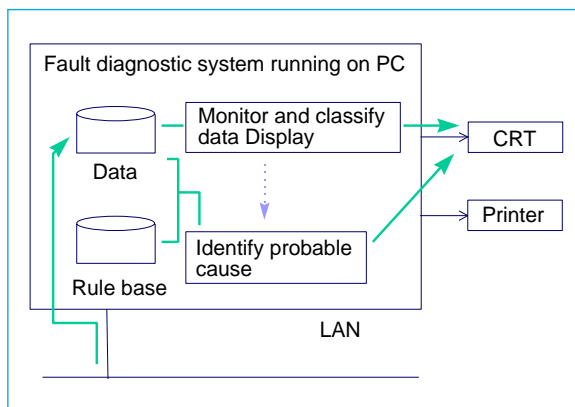

Fig. 3 Software configuration

**Typical System Application**

The effectiveness of the diagnostic system is illustrated here by looking at a typical application, in which it is used to determine the cause

of faults when the leading end of a strip is fed into a finishing stand.

The diagnostic system consists of two main functions, one for analyzing the status when a problem occurred, and the other for identifying the cause.

**Status analysis function**

Rolling faults in a finishing mill can occur when excessive strip tension between stands results in strip breakage, or when inadequate strip tension leads to pinching and the like, causing the rolling mill to decelerate (or be stopped by the operator) due to the increased rolling force.

Essentially problems of this nature can be caught by monitoring tension and mill speed; but this system goes further, analyzing the production process based on collected data to determine how the strip breakage or deceleration occurred.

First of all, it checks mill speed, rolling force, and looper height between stands to locate the stands where the problem arose. This preliminary step reduces the amount of data that must be analyzed in the next step.

After the location has been found, it analyzes various data gathered upstream of that point after rolling was started, determining the states that were passed through from the start of rolling.

Normally, problems of this sort occur for very brief instants, making it difficult to detect them by human analysis of charts or other data. This system is able to do so by time-checking of sampled results data.

The flow of events leading up to a fault when the leading end of a strip passes through a mill has the relationship shown in the state transition diagram in Fig. 4. These relational flow charts and various state-transition conditions are registered in a rule base for use in diagnosis. The system uses this rule base when carrying out its fault analysis.

Examples of collected data when a fault occurs are given in Fig. 5 and Fig. 6. Fig. 5 shows the rolling force at the work side and drive side between stands F6 and F7. Fig. 6 shows the looper angle between F6 and F7, the rolling speed at

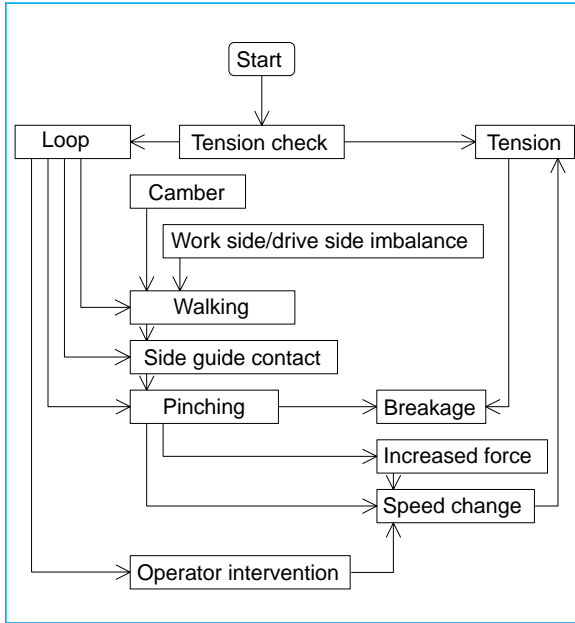

Fig. 4 State transitions (partial) during head end passage

these stands (reference and feedback), and the AGC control output. This example shows a typical chart when pinching occurs at stand F7.

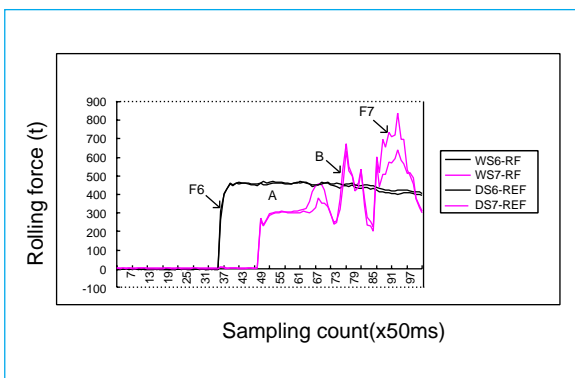

Fig. 5 Collected data (1)

**Analysis Results**

The data are analyzed as follows.

- Looper angle was not kept at the prescribed value even after the correction interval had elapsed but was allowed to continue rising to its maximum value. As a result it was deter-

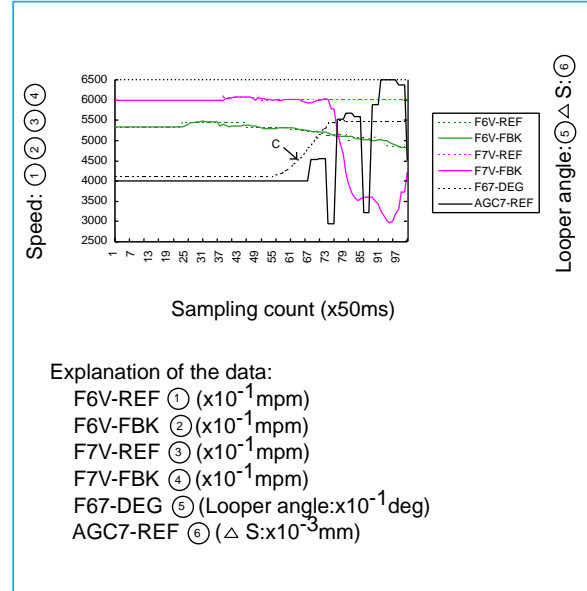

Fig. 6 Collected data (2)

mined that the looping state occurred after the start of rolling.

- Rolling force of stand F7 was normal after the start of rolling, but increased on both the work side and drive side at point A, continuing to increase over time. As a result it was determined that “walking” (lateral instability) occurred.
- Starting at point B, rolling force increased at the leading end to approximately 1.5 times normal, while the force remained unchanged at stand F6 (Fig. 5), causing a transition from a looping state to a walking state (point C). As a result it was determined that pinching had occurred.
- The subsequent increase in rolling force at stand F7 led to a rise in rolling torque, causing the motor-torque limiter to come into operation. The resulting deceleration at stand F7 resulted in a broken strip.

The system enables analysis like the above to be carried out in much less time than conventional human analysis of chart data. The result of this analysis is shown in Fig. 7.

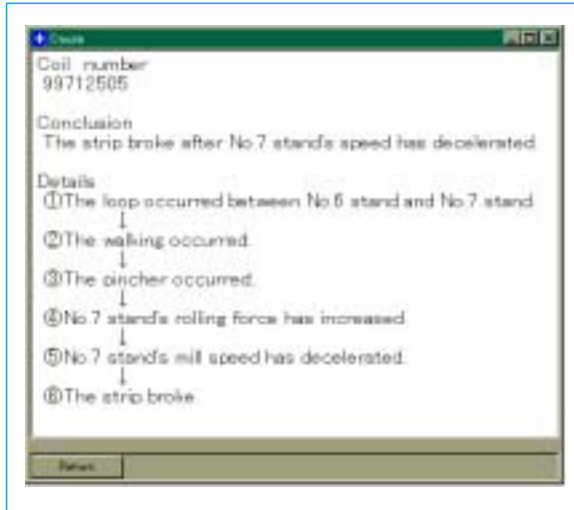

Fig. 7 Diagnostic result screen (typical example)

**Cause Identification Function**

The above analysis shows that the rolling fault occurred due to the looping state at the start of rolling. To determine the real cause, however, it is necessary to identify which function (or operator) performed the operation that caused the looping.

The main factors in looping are roll-gap position and rolling speed, and the functions relating to these are the four below:

1. Control systems (AGC or LCP)
2. Operator action (intervention)
3. Equipment trouble
4. Setup error

The basic rule for identifying fault causes here is mass flow between stands. In the case of items 1 to 3 above, account is taken of the effects of each control input on the mass flow designated at setup. If this control input effect exceeds the tolerable amount (threshold), then the function with the greatest influence is the primary suspect.

If all the control inputs are within tolerance, setup error is the likely problem. In this case a further comparison is made between the expected rolling force at each stand in setup and the actual measured force. This result, and the

actual mass-flow measurements, are used to determine whether the problem is in the force model learning function, in the temperature predictions (or entry temperature), or in the forward slip-ratio model. The rule base is applied to this decision-making process.

In the example given in Fig. 5 and Fig. 6, the analysis shows that this is not a control-system or operator-intervention problem but setup error. A further analysis of the setup error, comparing the expected rolling force and actual measurements, shows that the cause of looping between stands F6 and F7 is too great a strip thickness coming out of stand F6 and too little coming out of F7, due to overestimating the rolling force from F1 to F6 and underestimating at F7. The cause of the rolling force discrepancy is that the temperature at the finishing mill entry was below the lower limit and transformation occurred between F6 and F7.

**Future Enhancements**

A fault-diagnostic system for hot-strip milling control like that described here has been made possible by recent advances in computer data-storage capacity and networking speeds. The system is still in the prototype-evaluation stage; but continued efforts will be made to enhance its capabilities, making it applicable to online use and improving its storing and handling of manufacturing parameters.

Systems of this nature are sure to play an increasingly important role in raising steel-plant efficiency and easing the operator load. The goals of this development work are to realize a more accurate control model, accumulate more precise knowledge for identifying fault causes, and ultimately establish a technology for automatically reflecting the diagnostic results in control input. □

Note: Ethernet is a trademark of the U.S. company Xerox Corp.

# A Camber-Profile Gauge Using a Laser Scanning and Light-Guide Detection Edge Sensor

by Masayuki Sugiyama and Michihiko Hamaguchi\*

Controlling steel-plate camber (planar bending) in mill rolling is an important factor for maintaining high yield and preventing interruption of the mill-rolling operation. We have developed a camber-profile gauge that employs a new high-resolution edge sensor, using laser scanning and light-guide detection. This report describes the gauge and presents results of its application to camber control.

## Laser Scanning and Light-Guide Detecting Edge Sensor

Edge sensing is one of the most basic methods for measuring plate profile. Here we introduce a new method of edge sensing that uses high-resolution laser scanning and light-guide detection in place of the conventional sensing by CCD cameras.

## Edge-Sensor Measurement Principles

The hardware configuration of the newly developed edge sensor is shown in Fig. 1. A scanning

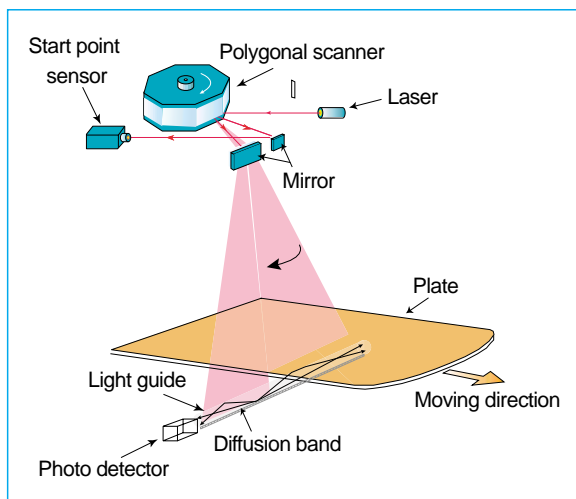

Fig. 1 Configuration of the edge sensor

laser beam is applied to the plate and to a light guide under the plate, in a direction perpendicular to that in which the plate travels, by means of a polygonal scanner. The laser beam is scat-

tered by a diffusion band inside the light guide, and the light guide is equipped with a photodetector that detects this light at the edge.

The edge-detection method is illustrated in Fig. 2. In this figure, the rise in the detector's signal

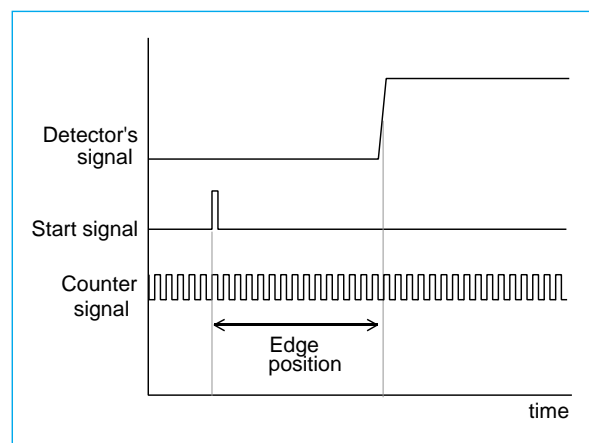

Fig. 2 Edge detection method

reveals when the scanning laser beam enters the light guide. By counting the number of counter signals between the start signal and the rise of the detector's signal, it is possible to detect the entry point of the laser beam and thus the edge position of the plate.

## Main Advantages of the Edge Sensor

Conventional methods of measuring plate edges are generally of the following three kinds.

1. Radiant energy detection: Cameras detect the energy radiated from a hot steel plate.
2. Back-light detection: Light from a source under the plate reveals its edge positions to cameras above the plate.
3. Reflected light detection: Light is beamed onto the plate and cameras detect light reflected from the plate.

A disadvantage of method (1) is that it cannot be used to measure steel plates at low temperatures. Method (2), which requires mounting a

\*Masayuki Sugiyama is with the Energy & Industrial Systems Center and Michihiko Hamaguchi with KOBELSTEEL, Ltd.

light source under the plate, has the problems of light-source reliability as well as installation space and cost issues. The main problem with method (3) is the large variation in reflectivity from the plate due to surface roughness, water, etc., making it difficult to obtain stable measurements. The edge-sensing method using the combination of laser scanning and light guide overcomes the disadvantage of (1) while representing an improvement over methods (2) and (3).

This edge sensor has the advantages that it is not affected by plate temperature or surface roughness; it has a compact structure; and it is not affected by ambient water vapor. Applying this high-resolution edge-sensing technology as described below, it is possible to measure plate width and planar bending.

**Camber Profile Gauge**

Camber, as noted above, is a planar bending that can occur along the length of a steel plate as it is milled by hot-rolling equipment. Because of its effect on the yield of usable sheet product, online measurements of camber profile should provide useful information for determining yield and for use in milling control. Discussed below is an application of the laser scanning and light-guide edge-sensing technology to camber-profile measurement.

**Gauge Configuration**

The camber-profile gauge we developed uses four edge sensors arrayed along the plate in its direction of travel. Each sensor consists of two laser-scanning mechanisms and one light guide to detect their light. This arrangement effectively eliminates the effects of vertical vibration, side “walk,” rotation or other noise caused by the moving plate. The noise from plate vertical vibration, warping and the like are eliminated by the stereoscope-like twin-laser scanning mechanism used to detect the edge coordinates of the plate. The layout of the four edge sensors measuring the profile of the moving plate is illustrated in Fig. 3. Edge sensors WS1 to WS3

measure camber profile, while the plate width and side walk are measured by the combination of edge sensors WS1 and DS (Here WS stands for work side and DS for drive side.)

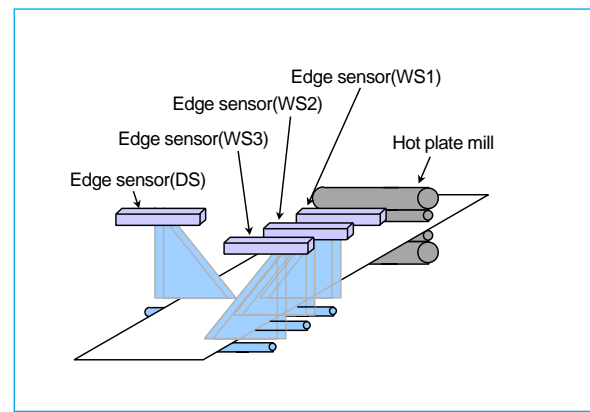

Fig. 3 Configuration of camber profile gauge

**Algorithm Used to Calculate the Camber Profile**

As a steel plate is transported through the milling process, it is subject to vibration noise perpendicular to its direction of travel and to rotation noise along the direction of travel. Because of these noise elements, it is not possible for one edge-sensor set to obtain accurate camber-profile measurements of a moving plate, as shown in Fig. 4.

When the locus of a steel plate measured while it is moving is represented as  $F(x,t)$ , this  $F(x,t)$  includes a rotational fluctuation component  $R(t) \cdot x$  and a side-walk (lateral fluctuation) component  $V(t)$ , as expressed in Eq. 1.

$$F(x,t) = f(x) + R(t) \cdot x + V(t) \dots\dots\dots \text{Eq. 1}$$

where

- $F(x,t)$ : Locus of measured plate edge
- $f(x)$ : Strip camber profile
- $R(t) \cdot x$ : Rotational fluctuation
- $V(t)$ : Side-walk (lateral fluctuation), and
- $x$ : Strip longitudinal position

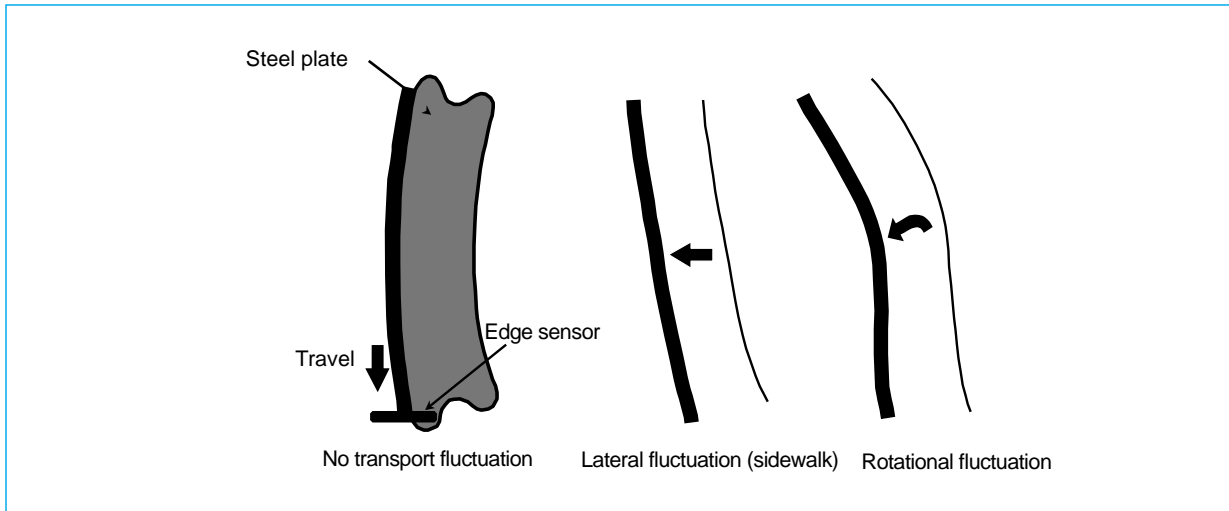

Fig. 4 Measurement of edge position

To eliminate the noise components and find the camber profile of the plate, we can make use of differential calculus and integral calculus. First the rotational fluctuation component  $R(t) \cdot x$  and lateral fluctuation component  $V(t)$  need to be eliminated as in Eq. 2, by second dimensional differentiation of Eq. 1 with respect to longitudinal position  $x$ .

$$\frac{\partial^2 F(x,t)}{\partial x^2} = \frac{\partial^2 f(x)}{\partial x^2} \dots\dots\dots \text{Eq. 2}$$

Integral calculus is then applied to Eq. 2 to find the camber profile  $f(x)$  as shown in Eq. 3.

$$f(x) = \iint \left[ \frac{\partial^2 F(x,t)}{\partial x^2} \right] dx \cdot dx \dots\dots\dots \text{Eq. 3}$$

Similar results to those in Eq. 2 can be obtained by means of an algorithm using differential calculus on the coordinates obtained by the three sets of edge sensors deployed along the direction of travel. The resulting differential values are then used to calculate the camber profile by an integrating process in accord with Eq. 3.

**Camber-Profile Gauge Features**

Camber could be measured in either of the following ways: using two-dimensional CCD cameras or the like to obtain images of the entire surface of the steel plate, or obtaining a series of measurements of the plate edge using the edge-measurement method described above, and calculating the entire surface of the plate based on these edge-position observations.

The first approach would require simultaneously measuring the entire surface of a plate that might extend for tens of meters, which would be difficult to do with the necessary resolution.

The second approach requires that noise components from the moving plate be eliminated when calculating the overall profile from the series of measurement results. The camber-profile calculation algorithm noted above can effectively eliminate such noise in the transport system.

The features of this algorithm are as follows. First, it makes possible measurement of the camber profile of a moving plate independent of the influence of lateral and rotational fluctuation. Second, it can calculate with high accuracy even a profile that cannot be resolved by approximate analysis using an n-order function.

**Effectiveness of Camber Control**

The basic steps in camber control are as follows.

1. Measure the camber resulting from various factors.
2. Set the target thickness (drive side and work side) for correcting camber on the next pass.
3. Set the roll-gap positions on the drive side and work side needed to achieve the target thickness.

It should therefore be possible to apply immediate feedback control on a plate undergoing rolling by installing camber-profile gauges along the mill, and in this way to enhance the effectiveness of measures against camber.

Fig. 5 illustrates the effect of this approach to camber control, in which the camber-profile gauge described here is used and position control is applied independently on the drive side and work side of the mill. This shows that average camber was reduced from approximately 38mm before the camber control to around 20mm after it was applied. It should be possible to improve on this result further by refining the control model.

The new sensing and control technologies introduced in this report, taking camber-profile gauge

development as an example, have great potential for raising steel-plant yield. That potential can be improved even further by additional development work, aimed at practical implementation of a thickness-control model that applies the laser-scanning techniques discussed here. Such a model would incorporate further refinements in sensing and camber control, resulting in new advances in process control. □

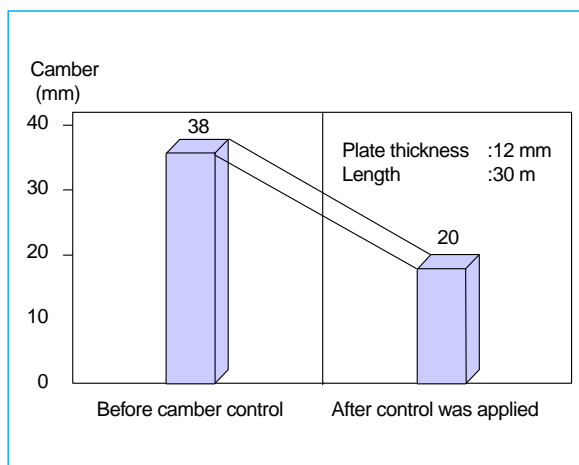

Fig. 5 Effectiveness of camber control using this technology

# MITSUBISHI ELECTRIC OVERSEAS NETWORK (Abridged)

Country	Address	Telephone	
U.S.A.	Mitsubishi Electric America, Inc.	5665 Plaza Drive, P.O. Box 6007, Cypress, California 90630-0007	714-220-2500
	Mitsubishi Electronics America, Inc.	5665 Plaza Drive, P.O. Box 6007, Cypress, California 90630-0007	714-220-2500
	Mitsubishi Consumer Electronics America, Inc.	2001 E. Carnegie Avenue, Santa Ana, California 92705	714-261-3200
	Mitsubishi Semiconductor America, Inc.	Three Diamond Lane, Durham, North Carolina 27704	919-479-3333
	Horizon Research, Inc.	1432 Main Street, Waltham, Massachusetts 02154	617-466-8300
	Mitsubishi Electric Power Products Inc.	Thorn Hill Industrial Park, 512 Keystone Drive, Warrendale, Pennsylvania 15086	412-772-2555
	Mitsubishi Electric Manufacturing Cincinnati, Inc.	4773 Bethany Road, Mason, Ohio 45040	513-398-2220
	Astronet Corporation	37 Skyline Drive, Suite 4100, Lake Mary, Florida 32746-6214	407-333-4900
Canada	Powerex, Inc.	Hills Street, Youngwood, Pennsylvania 15697	412-925-7272
	Mitsubishi Electric Research Laboratories, Inc.	201 Broadway, Cambridge, Massachusetts 02139	617-621-7500
Mexico	Mitsubishi Electric Sales Canada Inc.	4299 14th Avenue, Markham, Ontario L3R 0J2	905-475-7728
	Mitsubishi Electronics Industries Canada Inc.	1000 Wye Valley Road, Midland, Ontario L4R 4L8	705-526-7871
Brazil	Melco de Mexico S.A. de C.V.	Mariano Escobedo No. 69, Tlalnepantla, Edo. de Mexico	5-565-6269
	MELCO do Brazil, Com. e Rep. Ltda.	Av. Rio Branco, 123, a 1507, 20040, Rio de Janeiro	21-221-8343
Argentina	MELCO-TEC Rep. Com. e Assessoria Tecnica Ltda.	Av. Rio Branco, 123, a 1507, 20040, Rio de Janeiro	21-221-8343
	MELCO Argentina S.R.L.	Florida 890-20º-Piso, C.P. 1005, Buenos Aires	1-312-6982
Colombia	MELCO de Colombia Ltda.	Calle 35 No. 7-25, Oficinas No. 1201/02, Edificio, Caxdac, Apartado Aereo 29653, Bogotá	1-287-9277
U.K.	Mitsubishi Electric U.K. Ltd.	Travellers Lane, Hatfield, Herts. AL10 8XB, England	1707-276100
	Apricot Computers Ltd.	3500 Parkside, Birmingham Business Park, Birmingham, B37 7YS, England	21-717-7171
	Mitsubishi Electric Europe Coordination Center	Centre Point (18th Floor), 103 New Oxford Street, London, WC1A 1EB	71-379-7160
France	Mitsubishi Electric France S.A.	55, Avenue de Colmar, 92563, Rueil Malmaison Cedex	1-47-08-78-00
Netherlands	Mitsubishi Electric Netherlands B.V.	3rd Floor, Parnassustoren, Locatellikade 1, 1076 AZ, Amsterdam	20-6790094
Germany	Mitsubishi Electric Europe GmbH	Gothaer Strasse 8, 40880 Ratingen	2102-4860
	Mitsubishi Semiconductor Europe GmbH	Konrad Zuse Strasse 1, 52477 Alsdorf	2404-990
Spain	MELCO Iberica S.A. Barcelona Office	Poligono Industrial "Can Magi", Calle Joan Buscallà 2-4, Apartado de Correos 420, 08190 Sant Cugat del Vallés, Barcelona	3-589-3900
Italy	Mitsubishi Electric Europe GmbH, Milano Office	Centro Direzionale Colleoni, Palazzo Perseo-Ingresso 2, Via Paracelso 12, 20041 Agrate Brianza, Milano	39-60531
China	Shanghai Mitsubishi Elevator Co., Ltd.	811 Jiang Chuan Rd., Minhang, Shanghai	21-4303030
Hong Kong	Mitsubishi Electric (H.K.) Ltd.	41st Floor, Manulife Tower, 169 Electric Road, North Point	510-0555
	Ryoden Holdings Ltd.	10th Floor, Manulife Tower, 169 Electric Road, North Point	887-8870
	Ryoden Merchandising Co., Ltd.	32nd Floor, Manulife Tower, 169 Electric Road, North Point	510-0777
Korea	KEFICO Corporation	410, Dangjung-Dong, Kunpo, Kyunggi-Do	343-51-1403
Taiwan	MELCO Taiwan Co., Ltd.	2nd Floor, Chung-Ling Bldg., No. 363, Sec. 2, Fu-Hsing S. Road, Taipei	2-733-2383
	Shihlin Electric & Engineering Corp.	No. 75, Sec. 6, Chung Shan N. Rd., Taipei	2-834-2662
	China Ryoden Co., Ltd.	Chung-Ling Bldg., No. 363, Sec. 2, Fu-Hsing S. Road, Taipei	2-733-3424
Singapore	Mitsubishi Electric Singapore Pte. Ltd.	152 Beach Road #11-06/08, Gateway East, Singapore 189721	295-5055
	Mitsubishi Electric Sales Singapore Pte. Ltd.	307 Alexandra Road #05-01/02, Mitsubishi Electric Building, Singapore 159943	473-2308
	Mitsubishi Electronics Manufacturing Singapore Pte. Ltd.	3000, Marsiling Road, Singapore 739108	269-9711
	Mitsubishi Electric Asia Coordination Center	307 Alexandra Road #02-02, Mitsubishi Electric Building, Singapore 159943	479-9100
Malaysia	Mitsubishi Electric (Malaysia) Sdn. Bhd.	Plo 32, Kawasan Perindustrian Senai, 81400 Senai, Johor	7-5996060
	Antah MELCO Sales & Services Sdn. Bhd.	3 Jalan 13/1, 46860 Petaling Jaya, Selangor, P.O. Box 1036	3-756-8322
	Ryoden (Malaysia) Sdn. Bhd.	2nd Fl., Wisma Yan, Nos. 17 & 19, Jalan Selangor, 46050 Petaling Jaya	3-755-3277
Thailand	Kang Yong Watana Co., Ltd.	15th Floor, Vanit Bldg., 1126/1, New Petchburi Road, Phayathai, Bangkok 10400	2-255-8550
	Kang Yong Electric Co., Ltd.	67 Moo 11, Bangna-Trad Highway, Km. 20 Bang Plee, Samutprakarn 10540	2-312-8151
	MELCO Manufacturing (Thailand) Co., Ltd.	86 Moo 4, Km. 23 Bangna-Trad, Bangplee, Semudparkarn 10540	2-312-8350-3
	Mitsubishi Elevator Asia Co., Ltd.	Bangpakong Industrial Estate, 700/86-92, Moo 6 Tambon Don Hua Roh, Muang District Chonburi 20000	38-213-170
Philippines	Mitsubishi Electric Asia Coordination Center (Thailand)	17th Floor, Bangna Tower, 2/3 Moo 14, Bangna-Trad Highway 6.5 Km, Bangkawe, Bang Plee, Samutprakarn 10540	2-312-0155-7
	International Elevator & Equipment, Inc.	Km. 23 West Service Road, South Superhighway, Cupang, Muntinlupa, Metro Manila	2-842-3161-5
Australia	Mitsubishi Electric Australia Pty. Ltd.	348 Victoria Road, Postal Bag No. 2, Rydalmere, N.S.W. 2116	2-684-7200
New Zealand	MELCO Sales (N.Z.) Ltd.	1 Parliament St., Lower Hutt, P.O. Box 30-772 Wellington	4-569-7350
<b>Representatives</b>			
China	Mitsubishi Electric Corp. Beijing Office	SCITE Tower, Rm. 1609, Jianguo Menwai, Dajie 22, Beijing	1-512-3222
	Mitsubishi Electric Corp. Shanghai Office	Room No. 1506-8, Shanghai Union Building 100, Yanan-East Street, Shanghai	21-320-2010
Korea	Mitsubishi Electric Corp. Seoul Office	Daehan Kyoyuk Insurance Bldg., Room No. 1204 #1, Chongno 1-ka, Chongno-ku, Seoul	2-732-1531-2
Viet Nam	Mitsubishi Electric Corp. Ho Chi Minh City Office	8 B2, Han Nam Officetel 65, Nguyen Du St., 1st District, Ho Chi Minh City	8-243-984



