

ADVANCE

Mitsubishi Elevator & Escalator



Cover Story

* Inazawa Works' Test Tower (right)
 Test tower with a height of 173 meters is currently under construction on the premises of Inazawa Works, with completion slated for September, 2007.

* World Elevator and Escalator Expo 06 (left)
 Mitsubishi Electric Corporation's booth set up at the World Elevator and Escalator exhibition held in April, 2006, in China

• **Editorial-Chief**

Yoshikazu Mishima

• **Editorial Advisors**

*Chisato Kobayashi
 Yasuyuki Sano
 Hisao Okamoto
 Junichi Kitsuki
 Hiroaki Kawachi
 Masayuki Masuda
 Yasuo Nakayama
 Kiyoji Kawai
 Kazuhisa Hemmi
 Masahide Akagawa
 Hiroshi Yamaki
 Itsuo Seki
 Katsuhiko Hase
 Kazumasa Mitsunaga*

• **Vol. 115 Feature Articles Editor**

Kiyoji Kawai

• **Editorial Inquiries**

*Hisao Okamoto
 Corporate Total Productivity Management
 & Environmental Programs
 Fax +81-3-3218-2465*

• **Product Inquiries**

*Kazuhiko Okochi
 Manager, Planning & Administration Section
 Planning & Administration Dept.
 Overseas Marketing Division
 Building Systems Group
 Fax +81-3-3218-2895, 3594*

Mitsubishi Electric Advance is published on line quarterly (in March, June, September, and December) by Mitsubishi Electric Corporation.
 Copyright © 2006 by Mitsubishi Electric Corporation; all rights reserved.
 Printed in Japan.

CONTENTS

Technical Reports

Overview 1
 by *Shinichi Ito*

Delivered Spiral Escalators and Elevators for Overseas 2
 by *Koichi Mita, Atsushi Furukawa, and Hiroya Takaoka*

Compact Machine Room Elevators "NexWay-S" 5
 by *Atsushi Mitsui and Takao Nishida*

Elevator/Escalator Monitoring System Utilizes Web-based Technology "MelEye" 8
 by *Hiroaki Hamaji and Shin-ichi Kuroda*

Safety of Doors for "AXIEZ" MITSUBISHI Standard Elevators... 12
 by *Masahiko Koketsu and Toshio Masuda*

Elevator Modernization "ELEMOTION" 15
 by *Satoshi Yamasaki*

Technical Highlight

Variable-speed Elevator System with Programmable Electric Safety Device 19
 by *Yoshitaka Kariya and Akihiro Chida*

New Product

Finger Identification Device By Penetrated Light 23
 by *Takehiro Ohashi*

Overview



Author: *Shinichi Ito**

Under the slogan of "Quality in Motion", we, Mitsubishi Electric Corporation, have been globalizing our elevator and escalator business while maintaining commitment to quality and customer focus. As a result, Mitsubishi elevators and escalators are now used in nearly 90 countries around the world.

We are continuing our globalization efforts by conducting research and development on our elevators and escalators in order to win the confidence of the customers with the best products and services for the long term.

The NexWay-S series which we are now introducing is upgraded from the GPS series, which has gained a solid reputation among customers worldwide for more than a decade. Also, the NexWay-S series is a newly developed standard-type elevator incorporating the design philosophy of the GPS series with our proprietary technologies. These include slim "Permanent Magnetic motor type" traction machines, which we developed in the process of producing ELENESSA-series machine-roomless elevator.

Meanwhile, for the Japanese domestic market we have released AXIEZ-series elevator. This is the world's first elevator to adopt a variable-speed system, incorporating an electronic safety device resulting in enhanced safety and convenience, which has resulted in an excellent technical reputation in the market.

We have also been developing not only such products, we have placed great importance on service and modernization. At Inazawa Works, which is our main factory, construction of the world's tallest elevator test tower is currently underway. In addition, we began constructing a new factory in China, which is estimated to account for one third of the world's demand today.

Through continuous research and development of new technologies and introducing better products and service at the right time, Mitsubishi Electric Corporation will continue to increase the number of customers of our elevators and escalators throughout the world.

Delivered Spiral Escalators and Elevators for Overseas

Authors: *Koichi Mita**, *Atsushi Furukawa**, and *Hiroya Takaoka**

The design of the appearance of elevators and escalators, which convey traffic vertically in buildings, is likely to have a great impact on the design of the entire building. In the construction of most buildings in Japan, there has been strong demand for elevators and escalators that look to be of high quality and special design. Recently, however, overseas projects have increasingly required high-grade and completely novel designs. This report presents case examples of special-appearance designs in the U.S.A., which is the birthplace of elevators and escalators industry, and also in China whose economy is growing rapidly.

1. Spiral Escalator for Forum Shops, Las Vegas, U.S.A.

This installation was Mitsubishi's first project in Las Vegas. The building was opened in October 2004 and is located along the so-called Strip Road, or Las Vegas Boulevard, the main street in Las Vegas. The building, which houses a shopping center, restaurants, and entertainment facilities, is one of the most famous buildings in Las Vegas. Mitsubishi Electric installed four spiral escalators, each of which is shaped like a spiral as the name suggests. Only Mitsubishi Electric can manufacture this unique escalator.

The truss of the spiral escalator is usually supported at two points, upper and lower landing end sections, and another two points at the intermediate section. The intermediate supports are held with supporting columns anchored to the floor below. However, these intermediate supporting columns extending from the building floor are likely to obstruct the space within the building and detract from the appearance. For Forum Shops, the construction company, the architect office, and Mitsubishi Electric jointly installed a structural box beam with the same radius of curvature as the escalator truss under the escalator truss. As a result, the intermediate supports were completely invisible. Photo 1 shows the appearance of the finished installation. The intermediate supports are completely concealed, thus successfully providing ample space under the truss. The spiral escalator is in harmony with the internal design of the building and creates a sophisticated appearance entirely suitable for Las Vegas, the world's largest entertainment city.



Photo 1 Outward form of spiral escalator

2. Special and unique elevator design for Shanghai Citibank Building, Shanghai, China

Today, Shanghai is growing explosively, and the high-rise buildings in the city are among the world's best, next to those in New York and Chicago. The Citi-

bank Building is located in the Pudong New Area which is the city's business district and has 40 stories above ground and 3 stories below ground. The building was designed by one of the leading architect offices in Japan. Mitsubishi Electric delivered 24 elevators and 4 escalators (a total of 28 units) to the building. The sixteen main passenger elevators feature jambs and landing doors with special etching patterns and stainless steel vibration finish that make them look simple yet stylish. As shown in Photo 2, a large hall lantern is placed beside the jamb frame that extends from the floor to the ceiling, which is powered by blue color LEDs. The lantern indication method for car arrival employs not the conventional blinking type but a unique flowing-type sequential illumination to indicate the direction of car running with the lamps lighting up one after another upward or downward. This is revolutionary design fascinates passengers. The interior of the elevator cab features a stainless steel super-black color, stainless steel vibration finish, and etching so that the stainless base metal is exposed. As a result, the black wall inside the cab is accentuated to give a solid and dignified impression. In addition, the rear side wall in the cab is covered with a lighting glass wall that extends from the car floor to ceiling with the same width as the landing door. Behind the glass wall, the light source panel lights up the entire glass wall evenly, which contrasts sharply with the black wall of stainless steel. Photo 3 shows the internal appearance of the elevator cab viewed from the lobby side.



Photo 3 Cab design viewed from lobby side

3. Observation elevator design for China Youth Travel Building in Beijing, China

Beijing today is undergoing a construction boom toward 2008 when the Beijing Olympics will be held. The China Youth Travel Building is located in central Beijing and has 20 stories above ground and 3 stories below ground, standing exactly on the border between the Old City and New City. The east-side and west-side lobbies of this building respectively have voids stretching up to the highest story and the outer walls of the voids are fully glazed. The west-side lobby void com-



Photo 2 Entrance design and large hall lantern

mands panoramic views of the Old City centering on the Emperor Palace, while the east-side lobby void has outstanding views of the New City where the construction boom is at its peak. Mitsubishi Electric delivered a total of 10 elevators to this building, including 6 observation elevators which are installed facing the fully-glazed outer walls of the east-side and west-side voids. As Photo 4 shows, the observation elevators run through the voids up to the highest story of the building. The entire front wall and part of the side walls of the elevator cars are glazed so that passengers can enjoy views of the city through the fully-glazed outer walls of the voids from inside the elevators.

The landing doors of the elevators on each floor and the lobby walls of the building are also furnished with transparent glass panels so that the cityscape of Beijing can also be viewed from the elevator landing door areas. For the frames of the landing doors and jambs, a stainless steel hair line finish was used for

harmony with the stylish design of the building itself. The jambs also act as supports for the glazed walls of the building. The jambs are designed to have sufficient dimensions and strength that satisfy both structural safety and panoramic views of the city. Photo 5 shows the design of the elevator hall. With part of the landing lobby area glazed, the safety devices of the elevators are all non-mechanical types (ultrasonic type and infrared ray type), designed so as not to spoil passengers' views when the car arrives on each floor. The mechanical members and parts such as guide rails, counterweights, car platforms and frames are painted in the same colors as elevator shaft walls. The elevator shaft walls employ a dual structure with decorative panels. The fixing of the rail brackets and electric wiring system, which often spoil the appearance of structures, are concealed in the space created within the dual structure walls to improve the design quality.



Photo 4 Observation cab running inside void area



Photo 5 Elevator hall design

Compact Machine Room Elevators “NexWay-S”

Authors: *Atsushi Mitsui** and *Takao Nishida**

“NexWay-S” is a standard compact machine room elevator in which the area of the machine room is the same as that of the elevator shaft cross-section. Mitsubishi Electric has developed a slim traction machine using a PM motor and a new compact control panel, with the result that the area of the elevator machine room is smaller than the conventional models. This elevator is designed to comply with codes in Europe and other countries for special engineering specifications for handicapped people as well as the Universal Design policies.

1. Product Specifications and Scope of Application

NexWay-S has been developed as a standard model for overseas markets and covers both the high travel and high speed range, centering on the GPS-III range not covered by ELENESSE. The elevator conforms to EN81-1 and the new GB Code, and will also conform to other local codes over time in the future. Table 1 shows the outline of this elevator and its scope of application.

Table 1 Product specifications and scope of application of NexWay-S

Nominal riding capacity	10 to 18 passengers	
Capacity	750 to 1350 kg	
Rated speed	60 to 105 m/min	120 to 150 m/min
Max. travel	105 m	120 m
Max. stops	36 stops	
Control method	VVVF control	
Roping	1:1 roping	
Traction machine	PM gearless traction machine	
Applicable car sizes	ISO and JIS standard sizes	

2. Brief Introduction to Development of NexWay-S

2.1 Space-saving technology

Recently, elevators have been increasingly designed to use space in buildings more efficiently. Elevators without a machine room have also been developed and introduced. However, when the travel is large or when an auxiliary panel as an optional device is necessary, a machine room is essential and typically occupies twice the floor area of the elevator shaft

cross-section. Mitsubishi Electric has developed a slim traction machine and a new compact control panel that reduce the floor area of the machine room to that of the elevator shaft cross-section. The engineering background and development progress of the slim traction machine and compact control panel that played key roles in the space-saving NexWay-S are described below. Figure 1 shows the general structures of NexWay-S and GPS-III.

In the NexWay-S, a slim traction machine using a PM motor is employed, while the conventional GPS-III employed a worm-gear type traction machine. This traction machine is equipped with a super-slim “Poki Poki Motor” featuring Mitsubishi Electric’s original stator core technology that requires far less space and about 20% less power during normal operation thanks to the greater efficiency of the gearless mechanism. In addition, since this elevator system employs 1:1 roping, the motor is larger in diameter and delivers more torque than that used for the traction machine of the standard elevator without a machine room, “ELENESSE”, with 2:1 roping. For the NexWay-S, three types of traction machines have been newly developed: 11-kW type,

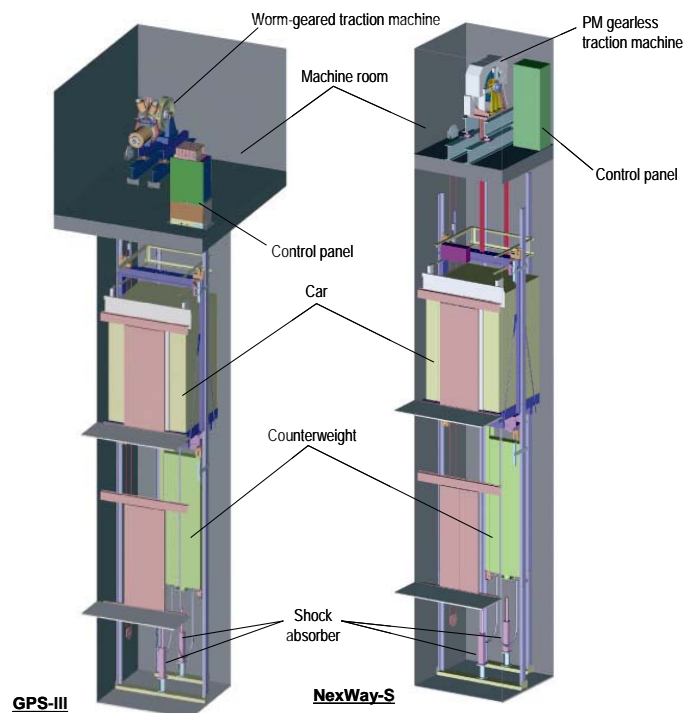

Fig. 1 General structures of NexWay-S and GPS-III

16-kW type, and 20-kW type. Figure 2 shows the appearance of the 11-kW type traction machine (for a load of 1050 kg or less and a speed of 120 m/min or less).

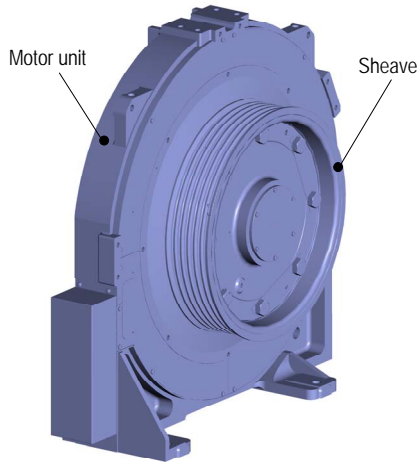

Fig. 2 Appearance of 11-kW traction machine

For the control panel, the main circuit unit was downsized and the layout within the control panel was rearranged to reduce the size by 15% compared to the conventional control panel, while making sure that the group control unit is housed in the control panel as with the conventional model.

Further, in order to comply with EMC (Electromagnetic Compatibility) regulations in Europe, measures for EMC such as the standard use of line filters and shielding are taken, with the result that Mitsubishi Electric obtained EN12015/EN12016 certificates for EMC for elevators and escalators.

The main circuit unit built into the control panel is a new type of IGBT with a low loss. A substrate-mounted small capacitor is used as a smoothing element. Laminated bus bars, with copper bus bars processed on the

bus bar wiring near the inverter element sandwiched with PET resin films, are used to provide insulation in the resin part and to reduce the space between bus bars. High-efficiency heat sinks are employed to reduce the size. For the controller, an LSI containing an original processor for motor drives controls the PM motor digitally with high accuracy, thus ensuring operational stability and high riding comfort.

2.2 Design

In 1997, Mitsubishi Electric introduced Universal Design to its elevators for the first time in the industry to develop and manufacture elevators that are user-friendly and comfortable for as many people as possible to ride. When designing the NexWay-S, special codes of European countries for people with disability were taken into consideration and Universal Design policies were respected for enhanced comfort and ease of use. Figure 3 shows the universal design elevator car.

(1) Car operating panel on the side wall

The car operating panel is installed on a side wall in compliance with the special codes for people with disability, such as EN81-70, and the operating panel is easily seen from the lobby when the landing door opens. Passengers need not turn around to operate floor buttons on the operating panel, which is a significant improvement for ease of use. The buttons are installed 1200 mm or less above the floor, for ease of use by passengers in wheelchairs and others with special needs.

(2) Tactile relief on control devices

The push buttons on the operating panel has tactile letters or marks for easy identification by vision-impaired people and the style of letters is easier to

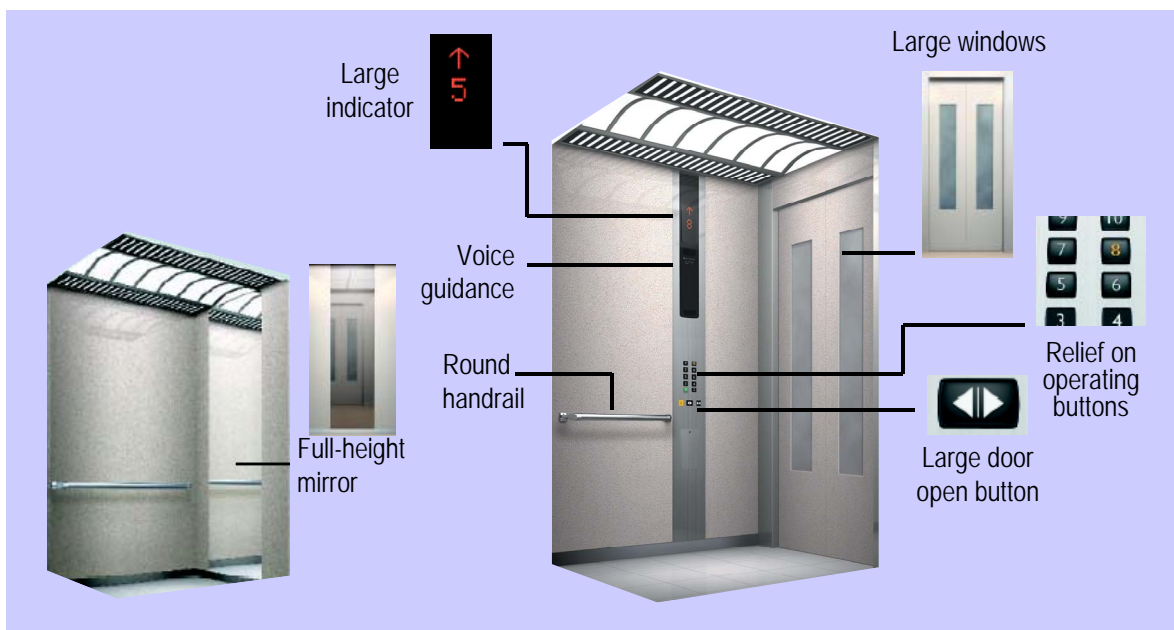

Fig. 3 Car employing universal design

read by people with weak eyesight.

(3) Other universal design item

The diameter of the handrail is increased slightly to 38 mm, and the gap against the wall is modified for a more secure grip. The indicators inside the car and door open/close buttons are enlarged for easier recognition. Optional extras, to meet further needs of customers for improved usability and riding comfort, include a voice-guidance system to announce the traveling direction of the elevator and approaching information, a full-height mirror that helps people in wheelchairs check behind them and makes the elevator car feel more spacious, and a door with large windows for a clearer view inside from each landing lobby and for crime prevention.

3. Engineering for higher product competitiveness

3.1 Application of high-traction rope

A high-traction rope is a rope impregnated with a special lubricant which has about a 30% higher coefficient of friction than lubricants used for standard wire ropes. High-traction ropes have been used for standard elevators delivered only within Japan, but for this particular building, we employed high-traction ropes for the first time overseas. Thanks to the higher traction, the weight of the entire mechanical system has been decreased by up to 10 to 15%.

3.2 Car platform and frame and car floor

The size of the car conforms to ISO standards, and the JIS standard size is also taken into consideration for compliance with the local market. The structure of the car is optimized for reduction of weight and cost.

3.3 New oil-filled shock absorber

Mitsubishi Electric's conventional shock absorbers, for speed ranges of 90, 96, and 105 m/min., have a high overall height that makes them unsuitable for the recent trend toward space-saving specifications. Mitsubishi Electric has purchased more expensive compact shock absorbers available in the market and used them in the elevators, and has now also developed its own cost-effective oil-filled shock absorber with the same total height as the purchased absorbers.

3.4 Door operating system

The NexWay-S also employs a direct-drive elevator car door system using the slim PM motor developed for the ELEPAQ-I and ELENESSE. As a result, the door operating system has been made smaller and lighter, and cost has been reduced through the shared use of parts among different models.

Elevator/Escalator Monitoring System Utilizes Web-based Technology “MelEye”

Authors: *Hiroaki Hamaji** and *Shin-ichi Kuroda**

We have developed a Web-based elevator/escalator monitoring system to expand the product lineup of such systems. This system is based on a host Web server and is able to display the real-time operating status of the elevator/escalator and images taken with a camera installed within the elevator car on the same personal computer, thus allowing the operating conditions to be monitored.

1. Background

Recently, buildings are being designed taller and for complex purposes, and are often called “intelligent buildings” and “office complexes.” Accordingly, the systems that monitor and control elevators and escalators, which are important means of transportation within the buildings, require higher performance, more versatile functions, and higher expandability. We have developed an elevator/escalator monitoring system based on new concepts and featuring state-of-the-art IT and network technologies. The features of the elevator/escalator monitoring system and related new technologies are outlined below.

2. Web-based elevator/escalator monitoring system

The Web-based elevator/escalator monitoring system is designed to monitor and control elevators and escalators in any size of building. A Web browser is used for display, so the system is expandable.

2.1 System configuration

Figure 1 shows the configuration of the system. A server personal computer that monitors and controls all elevators and escalators is installed in the building. This computer collects, stores, and processes the status signals from the elevators and escalators via dedicated communication interface boards, and is also connected with client personal computers, printers, etc. through another network.

The system can thus be expanded flexibly according to the use of the buildings; for example, the number of client personal computers can be increased for a building with two or more monitoring rooms.

Regarding the communication interface board, it plays an important role in unifying the communication interfaces between the server and the elevators and

escalators. The board employs a CPU which has been proven in actual elevator/escalator applications. With high-density and high-grade packaging technology, the interface hardware has been drastically downsized (Fig. 2). The real-time operating system of μ ITRON 4.0 specifications is used for greater reliability¹, and the board is connected with the server PC through an Ethernet network² to enable broadband, high-speed data transmission.

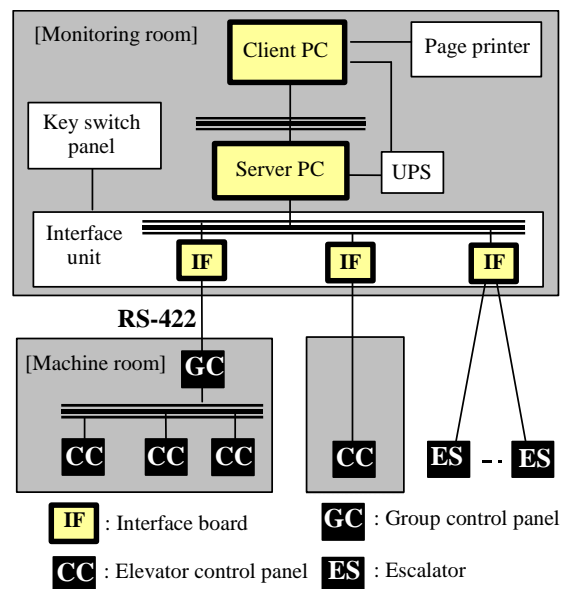

Fig. 1 System configuration of elevator/escalator monitoring system



Fig. 2 Interface board

¹ μ ITRON stands for Micro ITRON, ITRON for Industrial TRON, and TRON for Real Time Operating System Nucleus.

² Ethernet is a registered trademark of Xerox Corporation.

2.2 Software configuration

Figure 3 shows the software configuration of the monitoring system. The software consists of three major units: the display unit to display monitored data and setting screens, the server unit to process and control the monitored data and setting data, and the communication unit to communicate with elevators/escalators. The main features of the software are described below.

- (1) Display screens are created using Java³; the functions and operations of the display screens do not depend on the hardware or the operating system.
- (2) The Web browser handles the display, so a Java applet is downloaded from the server to the client PC for execution. This means that elevators/escalators can be monitored at any place

where there is a PC with Web browser.

- (3) The specification files containing such data as the number of elevators/escalators and the number of stories in the building are saved as CSV (Comma Separated Value) files, so the data can be easily edited and set. Monitoring screens reflect the settings in the specification files automatically, thus greatly reducing the time required for setting the system.
- (4) All characters displayed on the screens are represented by Unicode method, so the system can handle foreign languages.

2.3 System functions

The system screens are easy to view and are displayed in real time. For example, the Plan View Screen displays all the elevators at a time (Fig. 4), the Sec-

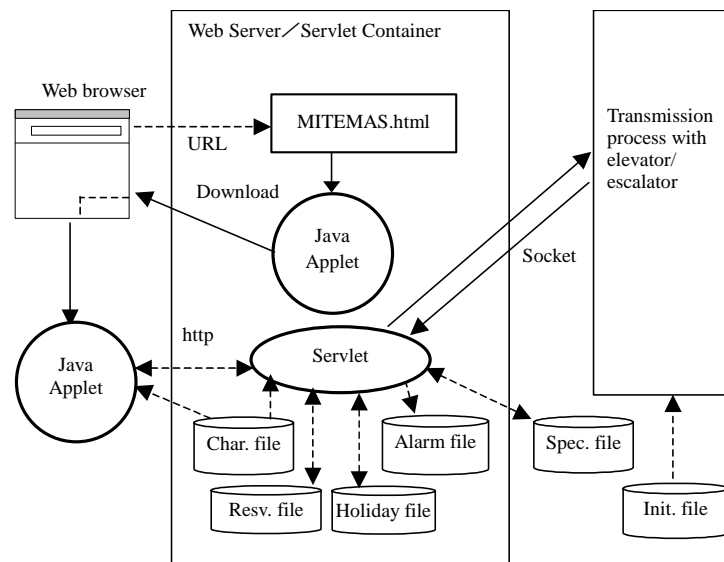

Fig. 3 Software configuration

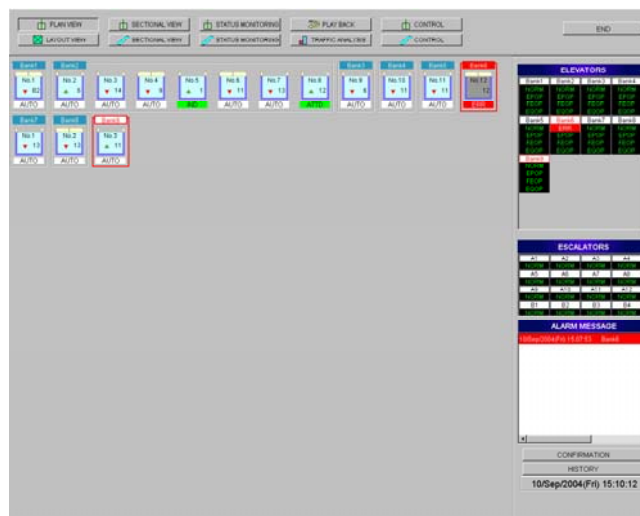

Fig. 4 Plan view screen

³ Java is a registered trademark of Sun Microsystems.

tional View Screen displays the operating status of the elevators/escalators at each bank graphically (Fig. 5), and the Status Monitoring View Screen displays the status in a conventional monitoring panel style (Fig. 6). Other system functions incorporated in this system include a Schedule Control Function for elevator scheduling, Failure History Display Function to display failures recorded in the past, Play Back Function to reproduce the operation of elevators/escalators in the past on the screen like videotape playback, and Traffic Analysis Function to display statistical data of waiting time, number of calls from each landing floor, and the like.

In designing the screens for these functions, emphasis was placed on ease of viewing, using, and understanding, while most operations can be done by mouse. To provide an overview of the entire building, the separate Layout View Screen shows a layout view upon inserting the symbols of the elevators/escalators.

3. Linkage of Web-based Elevator/ Escalator Monitoring System with Building Security System

3.1 Linkage with BMS

Building Management Systems (BMS) that manage various facilities in a building are increasingly designed on a multivendor basis for enhanced cost performance and engineering efficiency, and the open network scheme is also positively promoted for BMS. As a result, there is a growing need for data communication services to support the management system monitoring the facilities in the building to link the elevator/escalator monitoring system with BMS.

This Web-based Elevator/ Escalator Monitoring System links with BMS through a gateway computer, thus reducing the processing load of the server PC and improving operation reliability by clearly assigning functions to elements. The respective processing units of the gateway PC have a library formation so that the system linkage can be adjusted flexibly to meet

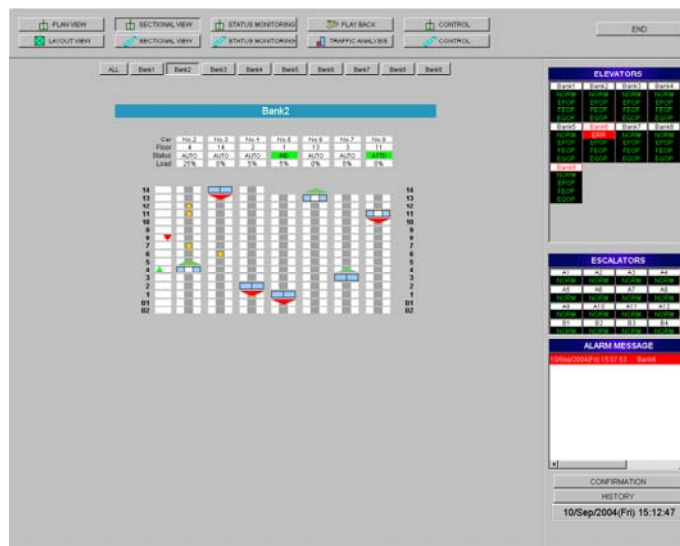

Fig. 5 Sectional view screen

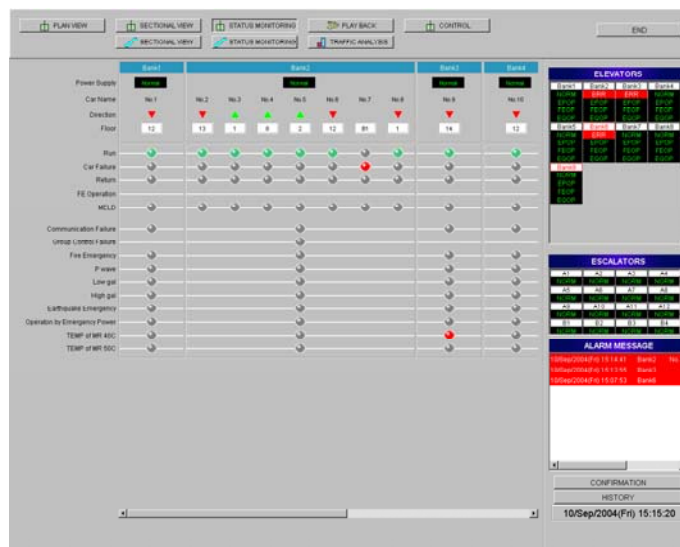

Fig. 6 Status monitoring view screen

changes in the specifications of BMS.

3.2 Linkage with camera monitoring system

Recently, there has been a growing need for monitoring not only the operation of elevators/escalators but also the images of the inside of elevator cars. Conventionally, an elevator/escalator monitoring system and a camera monitoring system for images within elevator cars have been installed as independent systems.

By using personal computers to monitor elevators/escalators, the two different monitoring systems can be linked easily. Figure 7 shows an example of a screen display of the linked systems.



Fig. 7 Monitor screen with video image

By using an exclusive server PC to store data of images within the cars and linking it with the playback function of the monitoring system, it is possible to display the status of an elevator and the inside view of the car at a certain time in the past.

By linking the two systems, safety measures for passengers in the event of an emergency can be taken efficiently and security against suspicious individuals or intruders can also be raised.

Mitsubishi Electric will continue to develop the elevator/escalator monitoring system to meet diverse needs for buildings that are becoming higher, more complex, and more intelligent, along with market-based needs and trends.

References

- (1) Hashiura, R., Iwaji, Y., Abe, T., Fukazawa, Y., and Suzuki, O. (1983). Elevator monitoring system for Shinjuku-NS building. *Mitsubishi Electric Technical Report*, Vol. 57 (2), pp. 178–180 (in Japanese).
- (2) Kojima, T., Nozato, T., Chiba, Y., and Yamaguchi, T. (2003). Framework for monitoring control system. *Mitsubishi Electric Technical Report*, Vol. 77 (7) (in Japanese).

Safety of Doors for “AXIEZ” MITSUBISHI Standard Elevators

Authors: Masahiko Koketsu* and Toshio Masuda*

Elevators are used by large numbers of unspecified individuals, from young children to elderly persons, as a means of vertical transportation inside buildings. Therefore, for elevator doors that open and close automatically, it is important to take safety measures to prevent them from hitting passengers upon closing, trapping fingers/hands in the gap between the entrance pillar upon opening, passengers tripping when entering and exiting, and the like. This paper introduces technologies for enhancing safety around doors.

1. Multibeam Door Sensor

Mitsubishi “AXIEZ”-series standard-type elevators come standard with Multibeam Door Sensor <2D> which is a two-dimensional sensor designed to detect passengers or objects between doors in a noncontact manner when the doors close. We have also developed a new Multibeam Door Sensor <3D> for detecting passengers who are on the landing side over a wider area.

In addition to the functionality of the Multibeam Door Sensor <2D>, the <3D> version has the ability to perform reversal, and open the doors which were closing, upon detecting a possible passenger on the landing side. This ability to detect passengers approaching from the landing side enhances passenger safety. The conventional 3D sensor-based scheme uses a photobeam projector which emits near-infrared rays on the landing side and a photobeam receiver installed on a door edge which receives light reflected off an object. The presence or absence of an object is detected by determining the optical power of the reflected light captured by the photobeam receiver. On the other hand, our new Multibeam Door Sensor <3D> employs an optical distance sensor based on triangulation, which measures the distance from the doors to a possible object and thus detects the presence or absence of an object within predetermined geographical boundaries. Figure 1 shows the configuration of the Multibeam Door Sensor <3D>. Each of the left- and right-hand doors is fitted with two optical distance sensor modules at different heights. Each of these four optical ranging sensor modules in all performs detection. Since distance measurements are not dependent on the size, reflectance and the like of an object, stabler detection operation can be achieved compared with conventional

3D-method sensors. Furthermore, the Multibeam Door Sensor <3D> can detect beds and carts which are not easily detected with conventional methods due to their smaller size and insufficient amount of reflected light compared with humans.

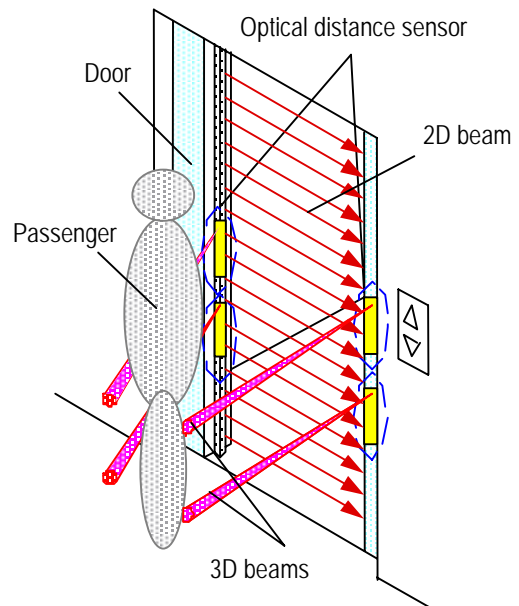

Fig. 1 3D-Multi beam door sensor

2. High-sensitive Door Opening Sensor

Typically, the gap between the door and the entrance pillar is approximately 5 mm, which is hard for a hand or the like to enter. However, the soft hands of children (infants in particular) could be drawn into this gap, so a sensor to detect the intrusion of fingers or hands into the gap while the doors are opening is adopted.

The door height is approximately 2 m from the floor to the top, and there is an opening-side space that spans from top to bottom into which the doors retract while opening. A sensor carefully monitors access to this open side, using a “beam shading method” by which detection is achieved by the blocking of a beam to ensure a high degree of detection reliability. However, since the beam shading method requires the photobeam projector and photobeam receiver to be placed on an imaginary straight line (i.e. within the same line of sight), they can hinder passengers getting on or off, the photobeam projector can be damaged by collision with entering/leaving carts, and false detections can be

caused by dust accumulation on the light-emitting surface. We have therefore installed a special prism for the light-emitting window of the photobeam projector so that the light beam is projected upward without sticking out from the photobeam projector from the pillar. Figure 2 shows the configuration of the high-sensitive door opening sensor.

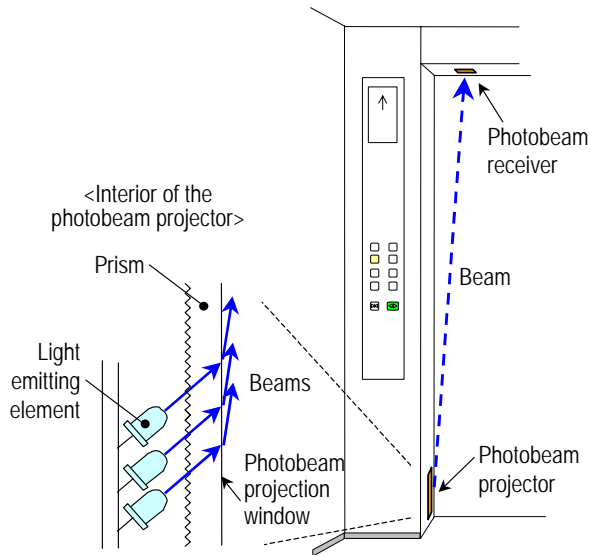

Fig. 2 Door sensor

In accordance with the state detected by the sensor, the doors are optimally controlled. The operation flow when the doors open is summarized in Fig. 3.

First, when the elevator arrives at a floor, if the high-sensitive door opening sensor detects a passenger or the like before opening the doors, an announcement saying "The doors will open. Please stand clear of the doors." is played to warn passengers that the doors will open, and prompt them to step back from the open side into which the doors are about to retract. If the sensor no longer detects an obstacle before the

announcement ends, the doors start to open normally, to keep the elevator functioning smoothly. If the sensor still detects an obstacle even after the caution message has been announced, and the doors open slowly while the door-opening warning buzzers sound.

If no sensor detection has occurred before the doors start opening and the sensor then detects an obstacle during normal opening operation, the doors are stopped once, then slowly opened to their fully opened position while the door-opening warning buzzer sounds. This is to make the passenger realize that he/she came too close to the elevator's door-housing structure, and to give them time to back away from the doors.

3. 10-mm Sill Interval

In the "AXIEZ" series, the sill interval (gap) has been reduced from 30 mm to approximately 10 mm, as was typical of the conventional series, in line with universal design. Figure 4 shows a sketch and a photograph of the elevator sill. The elevator doors are opened and closed as the car-door-mounted coupling device of the car door equipment driven by the door motor catches hold of the hall-door-mounted coupling device of the landing door equipment. When reducing the gap in the sill to approximately 10 mm, there was the problem of the hall-door-mounted coupling device of the landing doors, which is located above the doors, interfering with the sill of the car when the elevator travels upward/downward. To reduce the sill opening to a minimum while eliminating this equipment interference, we have provided a protrusion and an indentation only at the position where the coupling devices of the hall doors on the landing side are found above and below. This arrangement avoids interference between the landing and the car equipment and reduces the sill gap to approximately 10 mm. This not only reduces the

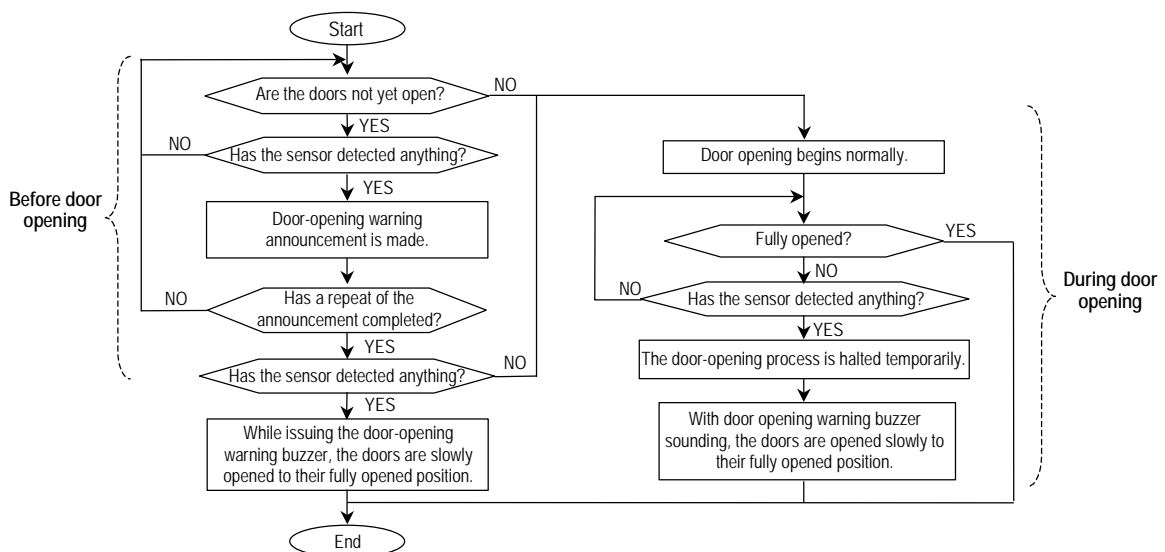

Fig. 3 The flow of door opening

chances of passengers tripping but also makes the wheels of wheelchairs and carts run more smoothly.

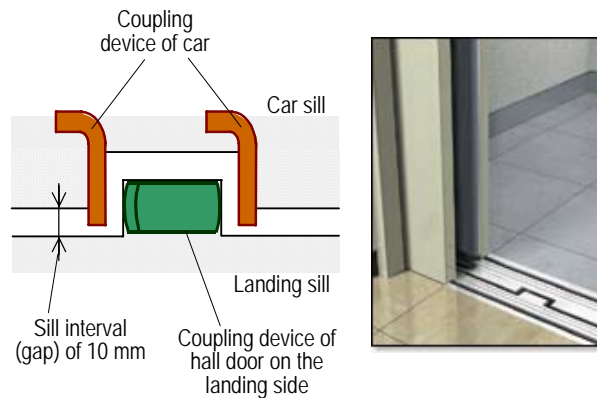

Fig. 4 Sill interval 10 mm

4. Sensitivity Enhancement of Door Load Detection

The door load detection function reverses the doors when the door motor torque exceeds a predetermined door load limit. However, since elevator doors may differ in design from floor to floor and may have suffered variations in door-mechanism load over the years, it used to be difficult to appropriately set the door load detection limiter. We have therefore made it possible to identify the motor torque value on a floor-by-floor basis after installation and to set the door load limiter accordingly. This process is shown in Fig. 5 and described below.

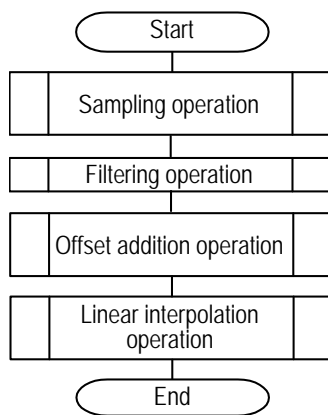

Fig. 5 The flow of the learning process

- **Sampling operation**

The whole range of door positions, from the fully closed position to the fully opened position, is divided into small sections and torque values measured at individual sampling points are buffered. Sampling is performed so as not to distort the torque waveform by varying the number of sampling points from section to section because the door torque can change abruptly in some sections and change gently in other sections.

- **Filtering operation**

To eliminate peculiar values and thereby prevent erroneous learning, filtering operation was conducted on buffered door torque values derived from several measurements made at each position.

- **Offset addition operation**

The door load limit value for each position is obtained by adding an offset value to the typical torque value that was determined by the filtering operation. The offset value to be added was determined and set such that load-detection sensitivity at the door edge becomes constant.

- **Linear interpolation operation**

The door load limit values determined by the learning operation at the individual positions are linearly interpolated to create a door load limit waveform. The same procedure is repeated on each floor to plot a door load limit waveform. With each successive door opening/closing operation, the waveform is updated to ensure optimum door load detection at all times.

This paper has introduced door safety technologies. We will continue to focus on enhancing the convenience and safety of elevators.

References

- (1) Kunikazu Koura, Shigeki Mizuno and Tatsushi Takahashi (1999). Sensors for placing intelligence on-board elevators. *Mitsubishi Electric Technical Report*, Vol. 73(8), pp. 578-581.
- (2) Tatsushi Takahashi and Masahiro Shikai (2003). High-sensitivity safety equipment for doors (Sensor application). *Mitsubishi Electric Technical Report*, Vol. 77(10), pp. 643-646.

Elevator Modernization “ELEMOTION”

Author: Satoshi Yamasaki*

Mitsubishi Electric Corporation developed the “ELEMOTION” Mitsubishi Elevator Renewal series, which are revamped models of elevators that have seen many years of service, to give them better functionality, performance and energy efficiency. We introduced the series in the Japanese domestic market in November 2001. Now, for overseas markets, we have increased the range of existing equipment which can be reused for partial modernization beyond that for the Japanese market. This paper introduces the features of the overseas “ELEMOTION”, featuring a broader range of (partial modernization) menus from which clients can select according to their budget and renovation schedule.

1. Overview

1.1 Concepts of ELEMOTION

With the theme of “More friendly to people and easy for anyone to use”, ELEMOTION epitomizes our commitment to producing high-quality, yet low-priced elevators which we have designed specifically for renewal purposes, based on the four E’s for the benefit of clients:

- Everybody: Easy to use by anyone
- Everywhere: Usable in any building
- Ecology: Kind on the environment
- Economy: Economically

1.2 Range of Application

Table 1 shows the range of application of overseas ELEMOTION. As shown, the target elevators are standard and custom type elevators that have a speed of 30 to 120 m/min, and capacity of 400 to 1,800 kg.

Table 1 Overseas ELEMOTION application range

Capacity Speed [m/min]	[kg]	400 to 1800
30 to 120	Application range	

1.3 Menu Options

Table 2 shows the ELEMOTION menu. It consists of four plans: CMA, CMB, CMC and CMD, in order of increasing amount of equipment to be replaced, with the CMA plan using the largest amount of already-available equipment. In addition to these four plans, the client can select between reusing and replacing the traction machine and/or traction motor. The step-up menu is thus configured to meet the needs of individual clients. Under the basic CMA plan, the major equipment that can be replaced includes the control panel, Landing Device, and terminal stopping device while car operating panels, traveling cables and door operator are reused for further use. Only under the CMA plan, a door I/F panel will be added for driving existing doors. Under the CMB plan, since door devices and car control panels are replaced in addition to those that get changed under CMA, the addition of a car station becomes necessary in place of the door I/F panel. Under the CMC plan, in addition to the items replaced under CMB, hall indicators and buttons at each landing are also replaced. And under the CMD plan, on top of what is replaced under CMC, the ceiling is replaced as well. Furthermore, where the traction machine and traction motor based on their existing installation conditions, and the classification is made as follows:

- 0: Both the traction machine and traction motor are reused.
- 1: The traction machine is reused while the traction motor is replaced.
- 2: Both the traction machine and traction motor are replaced.

For example, if only the motor is replaced under the CMC plan, this case is called “CMC-1”.

Table 2 Overseas ELEMOTION Menu

Menu	Range of replacements								
	Reuse of traction machine	Reuse of motor	Addition of door I/F panel	Major items of equipment reused					
				Load weighing device	Ceiling	Hall indicators and buttons	Car door operator	Car operating panel	Traveling cables
-0: Both traction machine and motor are re-used.									
-1: Traction machine is re-used while motor is replaced.									
-2: Both traction machine and motor are replaced.									
CMA	-0	○	○	○	○	○	○	○	○
	-1	○	▲	○	○	○	○	○	○
	-2	▲	▲	○	○	○	○	○	○
CMB	-0	○	○	▲	○	○	○	▲	▲
	-1	○	▲	▲	○	○	○	▲	▲
	-2	▲	▲	▲	○	○	○	▲	▲
CMC	-0	○	○	▲	○	○	▲	▲	▲
	-1	○	▲	▲	○	○	▲	▲	▲
	-2	▲	▲	▲	○	○	▲	▲	▲
CMD	-0	○	○	▲	○	▲	▲	▲	▲
	-1	○	▲	▲	○	▲	▲	▲	▲
	-2	▲	▲	▲	○	▲	▲	▲	▲

○: reused ▲: replaced

2. Development Details

This paper introduces details of a motor constant identification without rotation and a door I/F panel, which we have developed for our overseas ELEMOTION products.

2.1 Motor Constant Identification Without Rotation

(1) Objective

In order to implement vector control of an induction motor, circuit constants such as resistance and inductance become necessary. However, for overseas ELEMOTION (CMX-0) (X: A to D) menus, since the existing motor is to be reused, it is impossible to make prior motor-constant measurements and so it is necessary to perform motor-constant measurements in a preexisting building where the motor is installed. Conventionally, in order to identify motor constants, winding resistance measurement, no-load testing, and locked-rotor testing may be performed as prescribed in JEC-2137. However, with this method, it is impossible to perform no-load testing on a motor that has already been installed for an elevator. Since it must be tested somehow, we have devised a method of identifying motor constants without rotating the motor's rotor.

(2) Identification of motor constants

As an example of a motor equivalent circuit, a T-type equivalent circuit of an ordinary induction motor, is shown in Fig. 1, where R_s = Primary resistance, L_s = Primary leakage inductance, L_r = Secondary leakage inductance, M = Mutual inductance, R_r = Secondary inductance, i_s = Primary current, and v_s = Primary

voltage. Furthermore, T_s = Primary time constant, T_r = Secondary time constant and σ = Leakage coefficient are defined by the following equations (1) to (3):

$$T_s = \frac{L_s}{R_s} \quad (1)$$

$$T_r = \frac{L_r}{R_r} \quad (2)$$

$$\sigma = 1 - \frac{M^2}{L_s L_r} \quad (3)$$

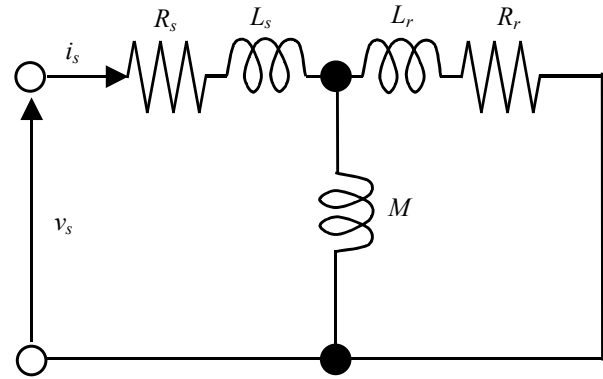

Fig. 1 Induction motor equivalent circuit of no rotation condition

The transfer function $G(s)$ from voltage “ v_s ” to current “ i_s ” can be expressed by Equation (4), where “ s ” = Laplacian operator:

$$G(s) = \frac{1}{R_s} \frac{1 + T_r s}{1 + (T_s + T_r)s + \sigma T_s T_r s^2} \quad (4)$$

The frequency response characteristics of the transfer function $G(s)$ are shown in Fig. 2. In order to identify the transfer function $G(s)$, it is necessary to measure the frequency response data of the output current with respect to the input voltage. In order to obtain the frequency response, frequencies to be applied are selected first and then alternating current is fed. The in-phase component and the 90-degree (quadrature) leading out-of-phase component of the alternating voltage with respect to the alternating current are extracted and recorded. On two stationary axes (α and β axes), a current command in the form of alternating current angular frequency ω_x is given by equation (5) below. When the alternating current is being fed on the α axis alone, the induction motor stays stationary and no interference occurs between the α and β axes. Therefore, the voltage on the stationary two axes becomes as given by the following equation (6). Because $i_{\beta s} = v_{\beta s}^* = 0$, it is possible to obtain the transfer characteristics of $v_{\alpha s}^*$ with respect to $i_{\alpha s}$.

$$i_{\alpha s}^* = I \sin \omega_x t \quad i_{\beta s}^* = 0 \quad (5)$$

$$v_{\alpha s} = V \sin(\omega_x t + \psi) \quad v_{\beta s} = 0 \quad (6)$$

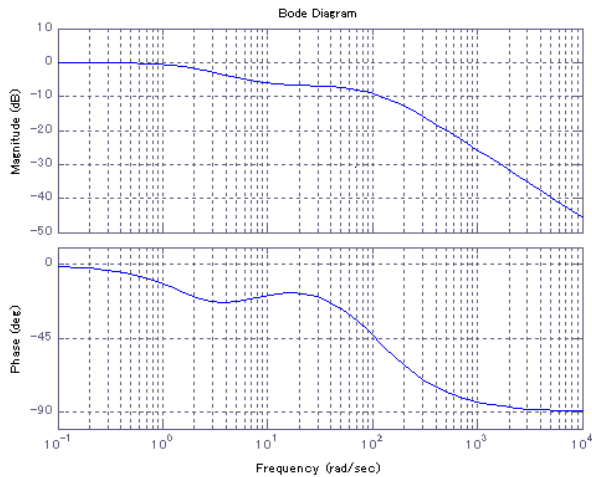

Fig. 2 Transmission characteristics of induction motor in no rotation condition

where $i_{\alpha s}^*, i_{\beta s}^*$ = Primary α -axis current command, primary β -axis current command
 $v_{\alpha s}, v_{\beta s}$ = Primary α -axis voltage, Primary β -axis voltage
 ψ = Phase difference

Letting the transfer characteristics of $v_{\alpha s}$ with respect to $i_{\alpha s}^*$ be $G_0(s)$, $G_0(j\omega_x)$ when the angular frequency of the alternating current $\omega_s = \omega_x$ is given by the following equation:

$$G_0(j\omega_x) = \text{Re}[G_0(j\omega_x)] + j\text{Im}[G_0(j\omega_x)] = \left| \frac{V}{I} \right| \cos\psi + j \left| \frac{V}{I} \right| \sin\psi \quad (7)$$

Since the amplitude I and $\sin\omega_x t$ of the alternating current are known, when $|V|\cos\psi$ and $|V|\sin\psi$ can be extracted from detecting voltage $v_{\alpha s}$, $G_0(j\omega_x)$ can be obtained. These extractions are performed by the following calculations:

$$\lim_{T \rightarrow \infty} \frac{1}{T} \int_0^T (\sin \omega_x t \cdot V \sin(\omega_x t + \psi)) dt = \frac{V}{2} \cos\psi \quad (8)$$

$$\lim_{T \rightarrow \infty} \frac{1}{T} \int_0^T (\cos \omega_x t \cdot V \sin(\omega_x t + \psi)) dt = \frac{V}{2} \sin\psi \quad (9)$$

Since I is known, $G_0(s)$ can be obtained by multiplying equations (8) and (9) by $2/I$. Once $G_0(s)$ has been obtained, the motor constants, which are coefficients of $G_0(s)$, can be obtained.

2.2 Door I/F panel

(1) System

In the case of an existing elevator which is a target for ELEMOTION, relays and contactors are installed inside the control panel for controlling the car door. Under the ELEMOTION menu CMA-X (X: 0 to 2), we

have decided to establish an after-modernization system where a door I/F panel is newly installed in addition to the control panel so that the car door is controlled by the door I/F panel. We have also enabled the door I/F panel and the control panel to communicate with each other by means of car serial transmission as in the case with other car equipment.

Figure 3 shows the door system applying the door I/F panel. As for the car's door operator, the existing equipment is reused while the door motor is controlled by switching between serial and parallel resistors that are connected with the door motor. As before, this arrangement allows the movement of the doors to be adjusted by adjusting the resistance inside the door I/F panel or door operator as well as existing.

Note that the door I/F panel also serves as an interface for the car operating panel, lighting fixtures and the like.

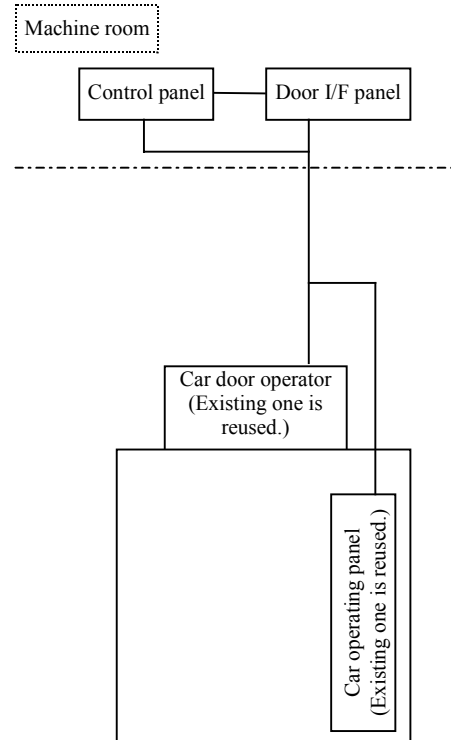

Fig. 3 Door system configuration

(2) Door I/F panel

Figure 4 shows a front view of the door I/F panel. The PC board inside this panel has been developed by designing door-control and -drive circuits and a door-periphery safety circuit in keeping with ELEMOTION's system design principles, both of which used to be configured using relays, etc. in the case of existing elevators. Furthermore, since we have made software-based control possible by incorporating a microcontroller, we have succeeded in improving the quality and functionality over conventional control circuitry, such as in the form of enhanced safety features. Furthermore, failure information is displayed on the control

panel in case of failure in the door I/F panel, just like information about the car station can be seen on the control panel after any of the CMB to CMD partial-modernization plans have been implemented.

Regarding regulatory compliance is concerned, laws and regulations of overseas countries are complied with. As for EMC (electromagnetic compatibility) in particular, optimum noise filter is installed to ensure conformance to EN12015 and EN12016.

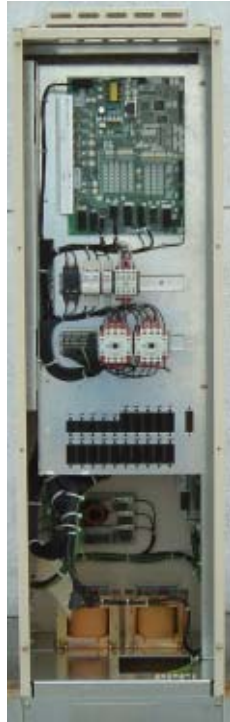

Fig. 4 Door I/F panel

3. Travel Performance

Figure 5 compares before-modernization and after-modernization travel performance in terms of velocity and car acceleration under the same conditions (i.e. a rated capacity of 600 kg, 90 m/min., and upward running). After modernization, vibration is virtually nonexistent during acceleration and deceleration. Likewise, velocity creep while stopped, as well as shock while stopping by braking, are almost nonexistent.

The before-modernization velocity curve shows that its after-modernization counterpart is characterized by increased smoothness, meaning that the ride comfort has been improved. Furthermore, floor-to-floor transit time has been shortened.

4. Future Prospects

This paper has described the features of “ELEMOTION” destined for overseas Mitsubishi-elevator renewal markets. In the Japanese market, we have already delivered about 6,000 units since November 2001. By launching “ELEMOTION” for overseas markets, we will boost sales overseas as well. Going forward, we are committed to continue developing models for renewal purposes and thereby expanding our elevator-renewal business.

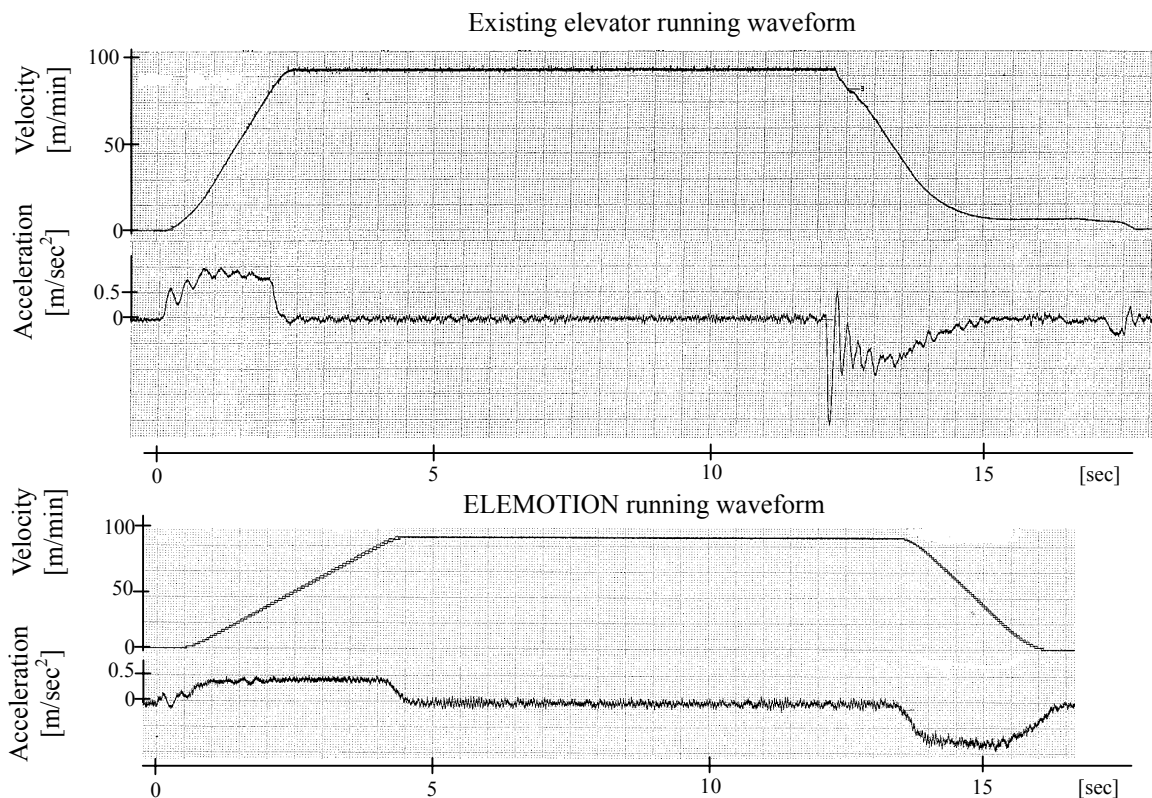

Fig. 5 Running performance (Above: before modernization, Below: after modernization)

Variable-speed Elevator System with Programmable Electric Safety Device

Authors: Yoshitaka Kariya* and Akihiro Chida*

Today, users demand improvements in elevator waiting time and traveling time. Therefore, Mitsubishi Electric Corporation has developed an elevator system which can vary the traveling speed within the allowable speed range of the drive system based on the number of passengers in the car (or the weight of the load being carried) and which can travel faster than its rated speed. We began marketing this system in January 2005.

Mitsubishi's standard-type machine-roomless elevator series "AXIEZ" incorporates a SETS (Smooth Emergency Terminal Slowdown) device, which is the world's first programmable electric safety device developed by us as a terminal slowdown device for steplessly checking overspeed. This SETS device saves space by reducing the hoistway space. By combining the SETS device with the variable speed elevator system, we have achieved the difficult feat of improving operation efficiency while saving space.

This paper introduces technologies behind the variable-speed elevator system and the programmable electric safety device.

1. Principle of Changing Traveling Speed

Generally, the required motor power P_m is given by the equation:

$$P_m = (M_{car} - M_{cwt}) \times V / \eta$$

where

M_{car} : Weight on the car side (= the sum of the weight of the car itself and the weight of the payload)

M_{cwt} : Weight of counterweight

η : Efficiency of elevator system ($\eta < 1$)

V : Traveling speed

Since the weight of the counterweight is chosen to balance the weight of the car plus half of the rated load-carrying capacity, the motor capacity P_{mt} can be chosen by using the following equation according to the capacity that is required when the car is loaded with its rated payload.

$$P_{mt} = M_t \times 0.5 \times V_t / \eta$$

where

M_t : Rated load-carrying capacity

V_t : Rated velocity

Therefore, provided the speed is varied while

maintaining $P_m \leq P_{mt}$, in other words, increasing the speed within a range in which the following expression holds

$$V \leq M_t \times 0.5 / (M_{car} - M_{cwt}) \times V_t$$

it is possible to increase the speed without having to increase the motor capacity. The above equation means that the closer the car's payload is to half the rated load-carrying capacity, the faster the speed can be increased. However, in addition to motor capacity constraints, the increase in speed is limited by the following:

- The motor current should not exceed the rated current (i.e., the motor current that is drawn when the elevator loaded with its rated payload travels at its rated speed).
- Constraints that arise from equipment performance which is affected by traveling speed such as noise generated during driving operation, and the braking performance and the like of the safety device.

2. Specifications of Variable-speed Elevator

The specifications of AXIEZ-series elevator systems with variable speed are shown in Table 1. The relationship between the load weight being carried and the speed is shown in Fig. 1. Speeds exceeding the rated speed are referred to as rated speed 1 at middle load (maximum speed) and rated speed 2 at middle load in the order of decreasing traveling speed. In the case of a model whose rated speed is 60 m/min., the maximum speed is 90 m/min. Since the difference between this maximum speed and the rated speed is too large, the midway point between these figures or 75 m/min. is set as the rated speed 2 at middle load for higher operation efficiency.

Table 1 Specifications of variable-speed elevator system

Item	Description		
Applicable models	For transporting passengers, for installation in homes, and for carrying beds		
Load capacity	450 kg to 1000 kg		
Rated speed	45 m/min	60 m/min	90 m/min
Rated speed 1 at middle load	60 m/min	90 m/min	105 m/min
Rated speed 2 at middle load	-	75 m/min	-
Acceleration & Deceleration	Acceleration: 0.55 m/sec ² , Deceleration: 0.7 m/sec ²		

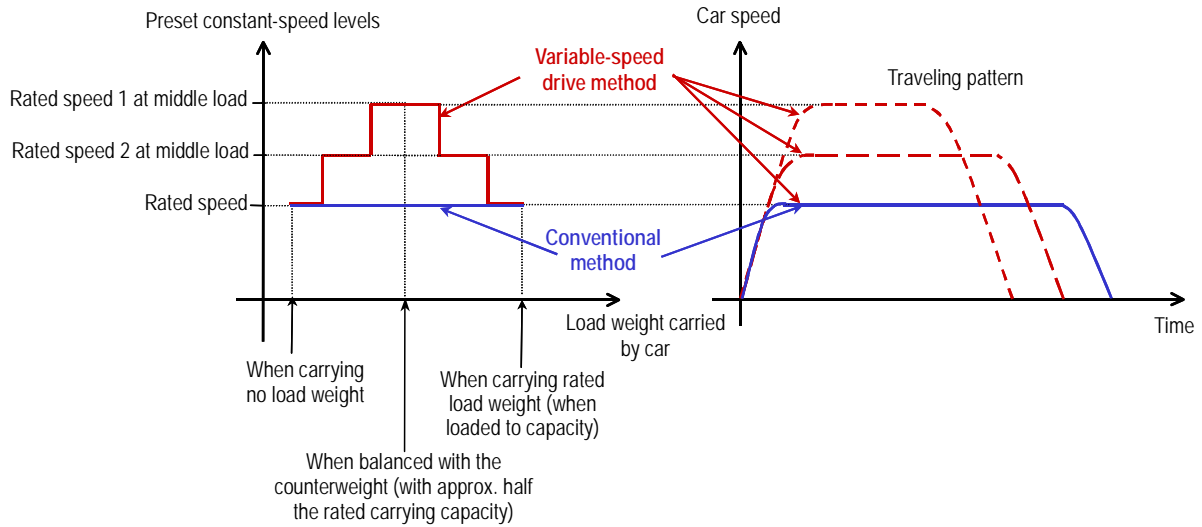

Fig. 1 Relationship between the load weight being carried and the speed

3. Variable-speed Elevator’s Operation Start Sequence

The operation start sequence of a variable-speed elevator system is shown in the flowchart in Fig. 2. As shown, the weight of the load inside the car is determined by a signal from the weighing device at the time of startup. In relation to the proportion of the load in the car as calculated from the weight of the load being carried, a speed setting at which to operate is made. To alert passengers when high-speed operation above the rated speed is about to start, the message “High-speed operation mode” is displayed on an LCD panel or display light inside the car.

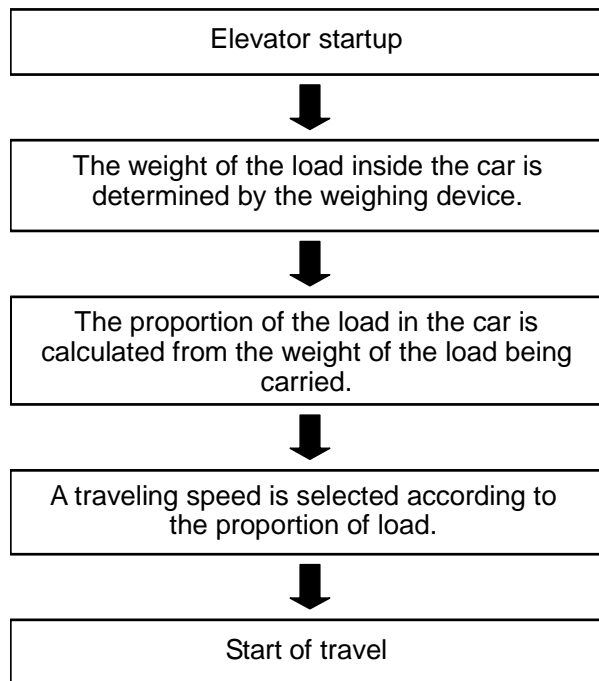

Fig. 2 Operation flowchart

Furthermore, to monitor the status of the drive system and protect it in the event of overheating, the following capabilities are provided:

- A capability to reduce speed upon detecting overheating in the drive system when traveling above the rated speed in the event of a failure in the weighing device or the like
- A capability to temporarily suspend variable-speed operation upon detecting overheating in the motor, inverter or the like, and then to resume the variable-speed operation when no longer overheated.

4. Effects of Variable-speed Elevator

This variable-speed elevator system offers the following benefits:

4.1 Improved efficiency through shorter waiting times

In computer simulations, variable-speed elevators in condominiums and office buildings reduced waiting times by up to 15% in relatively congested conditions such as during morning rush hours compared with conventional elevators. When cars are empty or loaded to near their capacity, there is no improvement since the cars travel at their rated speed. However, even during normal use, efficiency is improved by about 10%.

4.2 Improved efficiency through shorter ride times

Since travel speed can be increased by a factor of up to 1.5, ride times can be reduced. Particularly over longer travel distances, ride times are reduced more significantly.

4.3 Power consumption

Even though the elevator travels faster, the travel time is shorter, so the workload remains unchanged

from operation at a fixed speed. Therefore, power consumption remains almost the same as with any comparable conventional elevator.

5. System Configuration Using Programmable Electric Safety Device (SETS Device)

Figure 3 shows an elevator configuration with an electric safety device (SETS device). As shown, the same as conventional elevators, the variable-speed elevator system includes the following:

- i) Speed monitoring by a governor
- ii) A final limit switch which closes when the terminal floor is exceeded
- iii) A buffer which dampens shock in the event of the car or the counterweight colliding with the bottom of the hoistway

However, our newly developed programmable electric safety device (SETS device) can reduce the collision speed of the car (see Fig. 4) so a buffer having a shorter stroke is sufficient.

- iv) The encoder of the governor, which outputs two signals electrically independent of each other
- v) The standard position sensors, one installed near the upper end of the hoistway and the other near the lower end
- vi) The SETS control PCB to which the outputs of the above sensors are fed. The SETS control PCB, which exists in isolation from the control panel, detects the position and speed of the car and judges whether or not the car exceeded any preset speeds as a function of the car position near the terminal floor. If it detects overspeed, it operates the brake to forcibly decelerate the car and thereby reduce the speed of an imminent collision with the buffer.

6. Speed Monitoring by SETS Device

Figure 4 shows an overspeed monitor pattern of a conventional elevator and that of an elevator with the SETS device. Unlike the conventional elevator's gov-

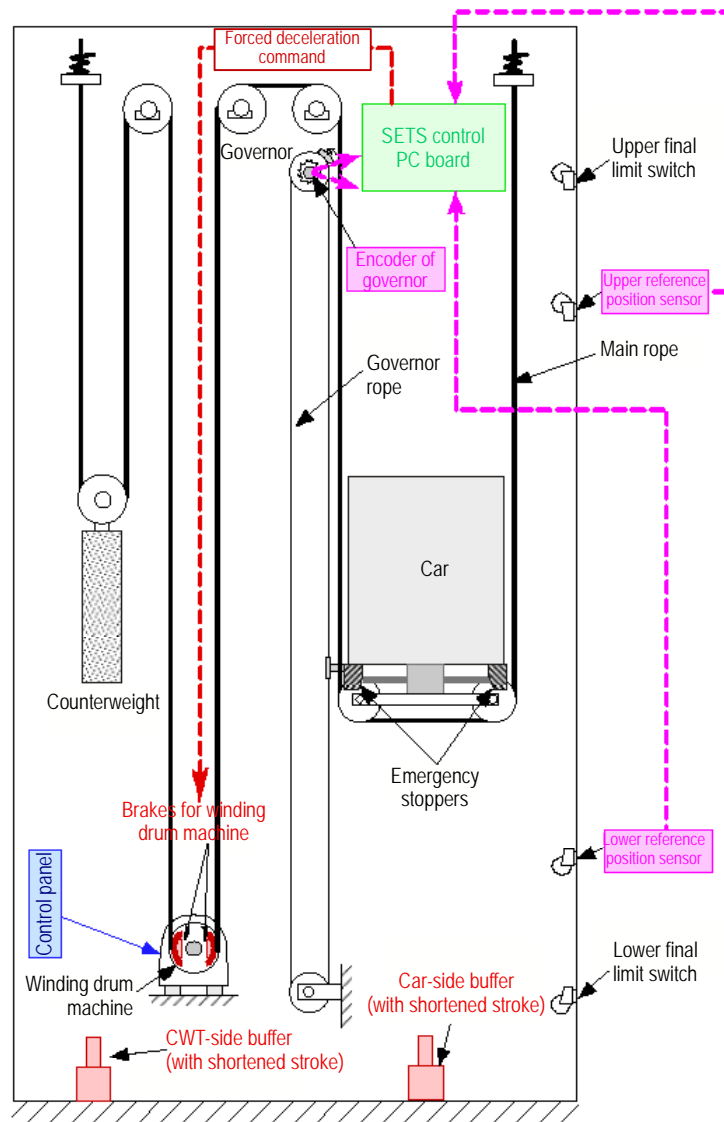

Fig. 3 Overall arrangement of elevator system adopting SETS device

error-based overspeed monitoring with a single decision level, the SETS device, which can electrically monitor for possible speed anomalies, can detect any overspeed quicker during deceleration in the terminal-floor section of the hoistway with reference to the car's position. Since the device thus minimizes the speed of collision with the buffer, the buffer can be downsized. As a result, we have achieved the industry's smallest headroom of 3,000 mm at rated speeds of 105 m/min. or less in the upper-end portion of a hoistway (when a standard slim, deluxe ceiling is used) while

maintaining the same level of safety, and have attained a shortening of up to 15%.

Our variable-speed elevator system with programmable electric safety device greatly improves operation efficiency for the benefit of users, while saving space for the benefit of building proprietors.

We will continue to working to meet diverse needs for elevators.

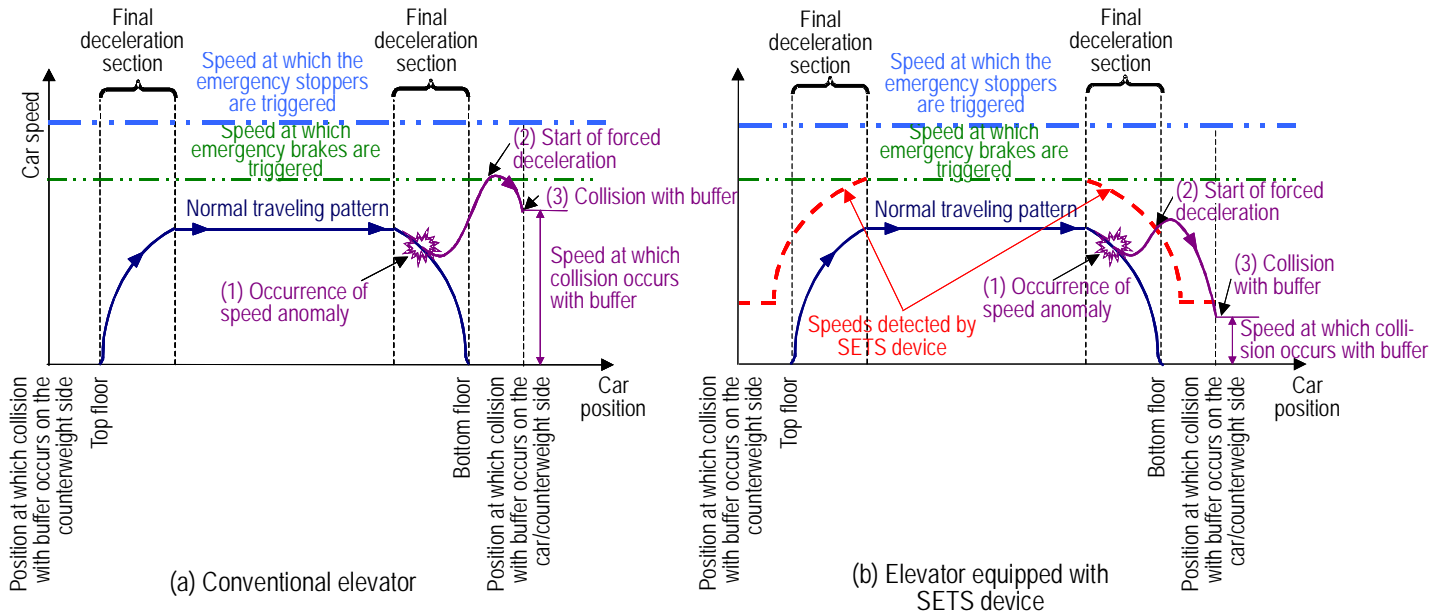

Fig. 4 Overspeed monitoring pattern

Finger Identification Device By Penetrated Light

Author: *Takehiro Ohashi**

Mitsubishi's Finger Identification Device By Penetrated Light went on sale in September 2005 in the Japanese domestic market, a device that is scarcely affected by usage environment or the state of the user's fingers. Detection is hygienic without contact, and fake fingers are securely recognized.

High security is achieved by using the world's first Transmittance Distribution Detecting method. This method can detect the dermis layer in the finger, so positive authentication can be performed consistently even in cold environments or with dry fingers. Availability rate is 99% or higher and false acceptance rate is 0.0001% or less. In this contactless method, light is irradiated from behind the nail side of the finger and the pattern of light after passing through the finger is captured by a camera placed on the side of the fingerprint.

Furthermore, fake fingers can be identified: the device can distinguish between real fingers and artificial ones made of silicone or the like, which conventional

contact-type fingerprint recognizers cannot do. Thus, concerns over possible identity theft by means of fake fingers are eliminated and security systems can be made much more secure.

This device comes in two versions: one is a desktop type (DT-TP) for such applications as log-in-to-PC control and network access control and the other is a gate-control type (OPG-TP) for the purposes of controlling access to classified areas. As for the DT-TP, since authentication and registration can be completed within the device, it can be embedded into safes and the like. The OPG-TP is capable of centrally managing access control for up to 40 gates. Both types permit the registration of up to 1,000 fingers.

Figure 1 shows how the DT-TP is used. It plugs into a USB port of any personal computer. The use of the device makes it possible to achieve positive security in whatever scenes.



Fig. 1 Finger Identification Device By Penetrated Light (Desk Top Type)

