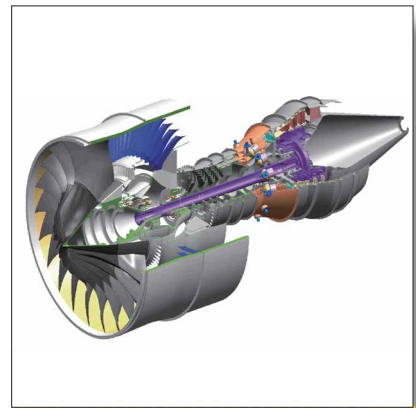


# ADVANCE

## Mechatronics



**Cover Story**

This issue introduces Mitsubishi Electric's state-of-the-art industrial processing machines. The photos shown on the front cover are:

- Upper left: The ultra-precision wire-cut electric discharge machine "PA05S"
- Upper right: "MS Coating" applicable to aircraft engine parts
- Center: New model industrial robots, the "RV-SQ/SD Series"
- Lower left: The two-dimensional high-production laser sheet metal processing system "ML3015NX-60CF-R"
- Lower right: The new model PCB laser drilling system "ML605GTW II-5150U"

• **Editorial-Chief**

*Takeshi Sugiyama*

• **Editorial Advisors**

*Chisato Kobayashi  
Shinji Iwasaki  
Makoto Egashira  
Koji Yasui  
Hiroaki Kawachi  
Masayuki Masuda  
Satoshi Itoda  
Kiyoji Kawai  
Kazuhisa Hemmi  
Taizo Kittaka  
Hidenori Takita  
Itsuo Seki  
Kazufumi Tanegashima  
Kazumasa Mitsunaga*

• **Vol. 123 Feature Articles Editor**

*Masahiro Suzuki*

• **Editorial Inquiries**

*Makoto Egashira  
Corporate Total Productivity Management  
& Environmental Programs  
Fax +81-3-3218-2465*

• **Product Inquiries**

*Hiroyuki Honda  
Marketing Planning Section  
Industrial Automation Machinery Marketing  
Division  
Fax +81-3-3218-6822*

**Mitsubishi Electric Advance** is published on line quarterly (in March, June, September, and December) by Mitsubishi Electric Corporation.  
Copyright © 2008 by Mitsubishi Electric Corporation; all rights reserved.  
Printed in Japan.

**CONTENTS**

**Technical Reports**

**Overview** .....1  
by *Nobuo Shogaki*

**Features of New Industrial Robot "SD and SQ" Series**.....2  
by *Takafumi Ishikawa*

**Motion Control Functions for Industrial Robots** .....5  
by *Kiyoshi Maekawa*

**Development of MSCoating for Aircraft Engine Parts**.....8  
by *Masahiro Okane and Akihiro Goto*

**High Quality Hard Metal Machining System, "ASC"** .....10  
by *Yoji Nakajima and Shuichiro Ishihara*

**CO<sub>2</sub> Laser Processing System "ML3015NX-60CF-R"** .....13  
by *Kazuo Sugihara and Takashi Inoue*

**Laser Drilling System ML605GTW II-5150U**.....16  
by *Mitsuhiro Kaneda and Toshiyuki Hokodate*

# Overview



Author: *Nobuo Shogaki\**

## Return to Monozukuri (Shop-floor Production)

In the 1990s after the collapse of the bubble economy, Japanese manufacturers shifted production overseas to reduce costs and slowly made essential improvements on the manufacturing floor. It was a decade of anxiety and uncertainty for the manufacturing industry.

However, in the early 2000s, the IT bubble suddenly inflated and then collapsed, dispelling such uncertainty. The trend toward globalized manufacturing turned toward production tailored to each local area and products that incorporate area-specific specifications. In response to the evolution of value-added products made in many types and quantities, the industry began enhancing global competitiveness by reforming domestic production systems. The challenge to improve manufacturing has started again, in a healthy and essential manner. Today, manufacturers must achieve not only good quality, delivery and cost of their products but also high social value, including consideration of the global environment and resources.

In cooperation with customers, the Industrial Automation Marketing Division of Mitsubishi Electric develops industrial products that offer high social value required by the manufacturing floor, and provides customers with such products including industrial robots, electric-discharge machines, and laser processing machines along with their numerical controllers.

# Features of New Industrial Robot “SD and SQ” Series

Author: Takafumi Ishikawa\*

## 1. Introduction

Robot controller mounted on the sequencer base!  
Mitsubishi Electric’s technologies and product series created this innovative approach.

This article introduces the SQ and SD series, new models among Mitsubishi Electric’s industrial robot products.

## 2. SQ/SD Series

In spring 2006, Mitsubishi Electric announced a new concept of “Integrated Platform,” which promotes coordination and optimization on the production floor. The SQ series are designed based on this concept.

### 2.1 Features of SQ series

#### 2.1.1 Lower system cost

In contrast to conventional robots, which are connected to a sequencer at the I/O level, the Integrated Platform has a robot controller mounted on a sequencer, and thus eliminates the need for an I/O unit and reduces the system cost (Fig. 1).

#### 2.1.2 High-speed communications with sequencer

Using the multi-CPU high-speed transmission function of the Integrated Platform, the time taken to transmit data between a sequencer CPU and robot is almost halved. This feature is most effective when frequent communications with the sequencer are programmed, and the higher the proportion of communications in the program, the shorter the cycle time.

#### 2.1.3 Improved control performance

A high-speed CPU improves the control performance to about twice the conventional level. This feature is particularly effective for programs that include many complicated numerical operations and positional data calculations. Combined with the high-speed communications capability, the cycle time is about 10% shorter in some cases. (Fig. 2)

#### 2.1.4 Wealth of extended functions

Unification with the sequencer brings a wealth of extended functions, allowing flexible support for the various requirements of manufacturing facilities. In addition, the SQ series can be easily connected with Mitsubishi’s Factory Automation (FA) products including GOT and general-purpose servo amplifiers, allowing total solutions for manufacturing facilities to be easily created.

The SQ series offer the features of FA products, while the SD series offer robotic features such as real-time operability and various interfaces. Both the SD series and SQ series have a dedicated architecture for the Integrated Platform.

### 2.2 Features of SD Series

#### 2.2.1 Improved control performance

The chassis design for effective heat dissipation allows a faster CPU speed, thus improving the control performance to about three times the conventional level. This feature is particularly effective for programs that

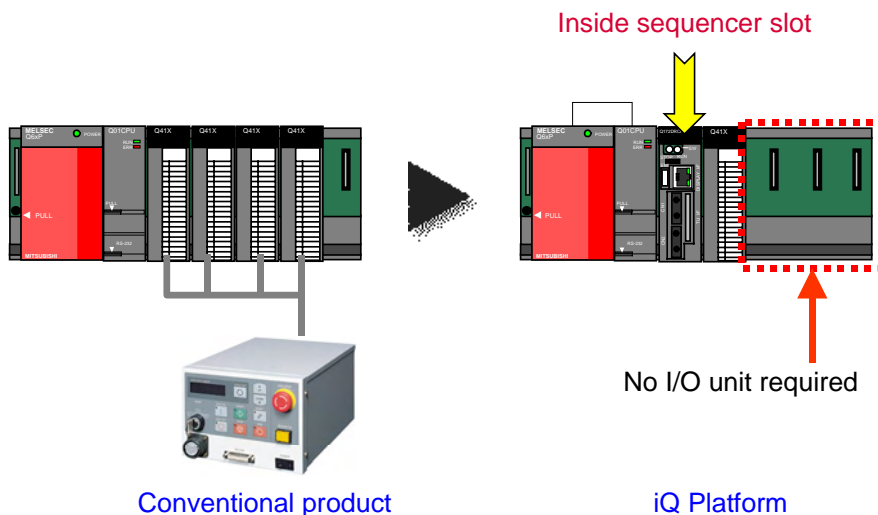


Fig. 1 System cost reduction

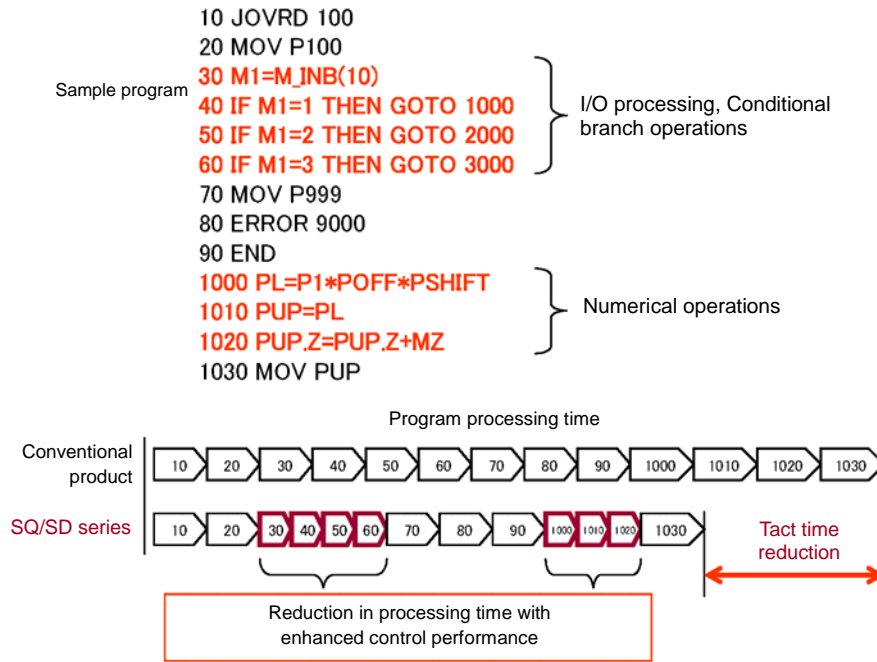


Fig. 2 Pattern diagram of processing time reduction

include many numerical operations and positional data calculations. The cycle time is about 16% shorter in some cases. (Fig. 2)

### 2.2.2 Enhanced communication capability

Ethernet, an option with conventional models, is now provided as standard. To reduce communication load, a specialized communication module was developed. Communication tasks are processed by this specialized module, and the architecture dedicated to the Integrated Platform (called the “main controller” hereafter) performs pseudo-communications with the specialized module in the background, resulting in better communication capability without increasing the load on the main controller.

## 3. Improved Robot Functionality

The new products are designed to maximize robot functionality by offering three operation modes. (Figs. 3–5)

### (1) Normal mode

Factory setting acceleration/deceleration patterns are the same as conventional products<sup>1</sup>. The new products have a much shorter current-control period, which enables more precise current control and reduces the effective motor current, i.e. lower motor load rate. In other words, by introducing a new robot into existing manufacturing facilities equipped with a conventional robot, more jobs can be done and productivity can be improved. (Figs. 4 and 5)

### (2) High-speed positioning mode

Positioning accuracy is improved and motor acceleration/deceleration time is reduced. Motor control gain is optimized in real time. In addition, a new scheme of generating operation commands enables maximum motor torque to be used and boosts high-speed operation. Note that the motor load rate is higher than the normal mode due to greater effective current. (Figs. 4 and 5)

### (3) High-precision tracing mode

The tracing accuracy of the tip of the robot arm is given top priority. This mode has the maximum motor control gain among the three modes, so tracking to the command value is enhanced. Furthermore, the command values are filtered to prevent the risk of overshoot, resulting in good tracking and tracing accuracy without overshooting. Note that the cycle time is longer due to the filtering of command values. (Fig. 5)

## 4. Greater Safety

Mitsubishi Electric has been improving safety ahead of the competition. In particular, all Mitsubishi products in the market, regardless of shipping destination, satisfy the requirements of safety category 3. The SQ/SD series comply with the latest Class-C standards for robots, ISO-10218. These standards cover not only the safety of the robot itself, but the total safety of the customers’ facilities. Compliance with these standards will raise the safety of customers’ facilities and increase the total added value of facilities.

<sup>1</sup> “Conventional products” refer to Mitsubishi Electric’s S series products, whose followers are SQ/SD series. As described above, the two series are categorized by the controller to be connected.

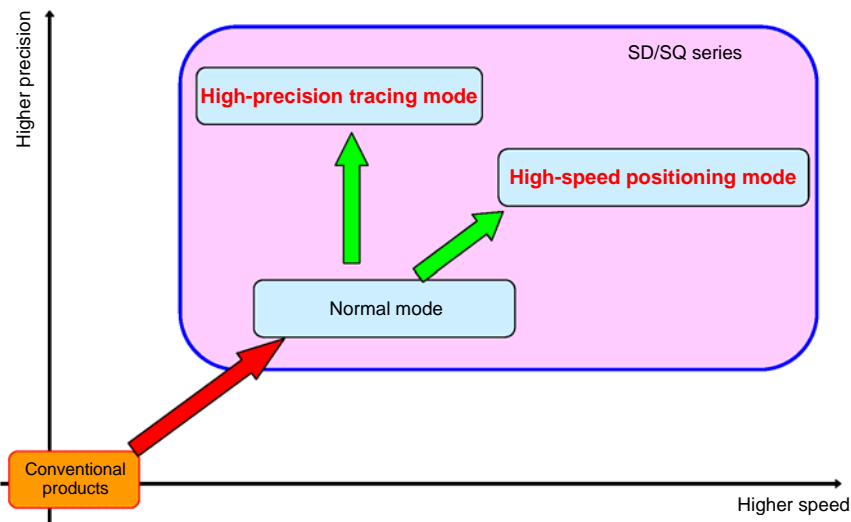


Fig. 3 Improved functionality of SQ/SD series - Pattern diagram 1

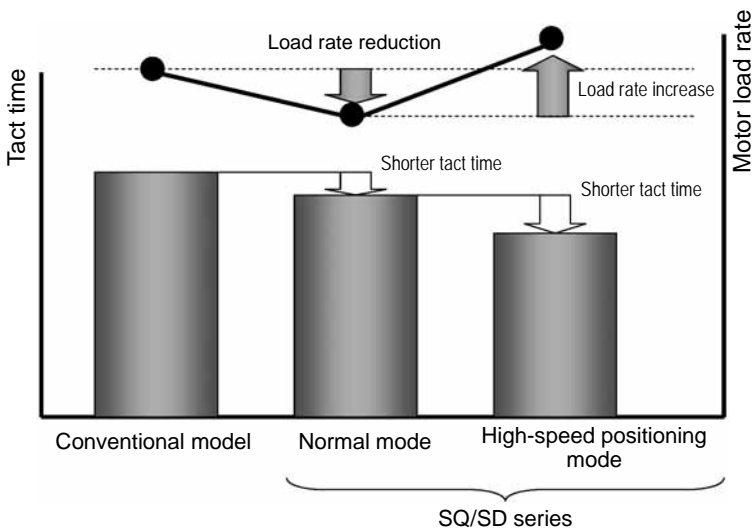


Fig. 4 Improved functionality of SQ/SD series - Pattern diagram 2

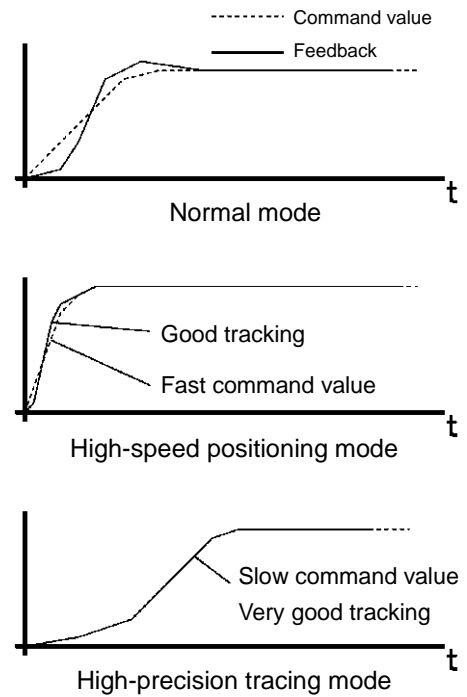


Fig. 5 Improved functionality of SQ/SD series - Pattern diagram 3

### 5. Conclusion

The SQ/SD series introduced in this article, with their significantly improved performance, will form the core of Mitsubishi's robot business, and lead the market with their characteristic two controller types. To use the full potential of the devices' high performance, we will develop humanized robotic items including various sensor interfaces with the external world, multiple arm control, and intelligent hands.

# Motion Control Functions for Industrial Robots

Author: Kiyoshi Maekawa\*

## 1. Introduction

In the industrial robot business, Mitsubishi Electric focuses on compact vertical and horizontal multi-joint robots. The company is working on enhancing their rigidity, improving the drive mechanisms such as the motors, and to develop robotic motion control functions. In the compact robot market, growing requests for the motion control functions include: faster cycle time and higher accuracy, better usability, and application specific functions.

To increase the speed of the cycle time, in addition to the improvement of drive mechanisms for higher velocity and higher acceleration/deceleration, we have introduced an optimal acceleration control, whereby the optimal acceleration/deceleration time is automatically calculated to minimize the traveling time according to the robot's position and posture and the load attached to the tip of the arm. We have also introduced an optimal path connection function that provides a shortest path connection under given constrained conditions and thus a shorter operating time, whereby the next move command is initiated without stopping at a route point that requires no positioning. In addition, to achieve higher accuracy, we have introduced a gravity compensation function, which corrects the deflection of each axis due to gravity.

Usability improvement functions include: impact detection function, which detects without any additional sensor when the robot's hand or body has hit an object and makes an emergency stop to reduce the damage to the robot and object; a position restoration support function, which reduces the number of teaching points

after replacing drive elements such as the motor and belt or after the robot has been reinstalled; and a maintenance forecast function, which analyzes the operating status of the robot to estimate the maintenance timing for lubrication, belt replacement, etc.

Application-specific functions include: an orthogonal compliance control function, which allows the robot to flexibly operate only in the direction specified by an orthogonal coordinate system; and a conveyer tracking function, which makes the robot operate following the conveyer movement.

This article introduces typical examples from these motion control functions.

## 2. Functions for Faster Cycle Time and High Accuracy

Even if a robot is operated at the same acceleration/deceleration rate and at the same velocity, the required driving torque varies depending on its position and posture at the start and end points of motion. Similarly, the required driving torque also varies when the mass of the load attached to the tip of the robot arm is changed. Meanwhile, the motor and reducer used on each robot axis have a maximum allowable torque. Consequently, if the robot is operated at the maximum velocity within the motor and reducer's constraint, the acceleration rate needs to be reduced when a heavy load is attached to the hand or the robot is operated in a stretched posture, because a greater driving torque would be required to produce the same rate of acceleration. On the contrary, in the case of a light load at the tip of the arm or the robot operation in a retracted



Fig. 1 Industrial robots

posture, operation at a high acceleration rate is possible (see Fig. 2). As such, the optimal acceleration function determines the acceleration rate optimized for each robot movement according to its position/posture and the load attached to the tip of its hand.

The equation of motion of the robot is expressed as:

$$\tau = M(q)a + h(q, v) + g(q) + f(v) \quad (1)$$

where  $\tau$  is the vector consisting of the driving torque of each axis,  $M(q)$  is the inertia matrix, and  $q$ ,  $v$ ,  $a$ ,  $h(q, v)$ ,  $g(q)$  and  $f(v)$  are the vectors consisting of the position, velocity, acceleration rate, centrifugal and Coriolis forces, gravity force, and friction force of each axis, respectively. The driving torque of the robot varies according to its position/posture and the load at the tip of its hand because the inertia matrix  $M(q)$ , centrifugal and Coriolis forces  $h(q, v)$ , and gravity force  $g(q)$  are functions of the position and posture of each axis.

Consequently, the optimal acceleration function uses the robot's equation of motion (1) to calculate the acceleration time and deceleration time that give the shortest motion time for each robotic movement within the constraint of motors and reducers. Since the inertia matrix is a function of the position of each axis, and hence varies during the operation, it is impractical to calculate the equation of motion (1) at every robot position during its operation due to computational complexity. Therefore, representative points are determined within the acceleration period and deceleration period, and the calculation of the equation of motion (1) is repeated at these representative points to calculate the acceleration time and deceleration time that give the shortest motion time within the constraint of motors and reducers, without increasing the calculation time.

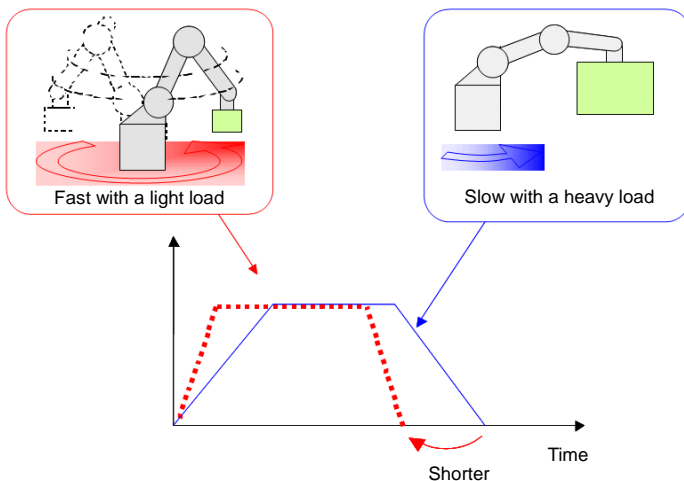


Fig. 2 Optimal acceleration

In addition, the constraint of the motor may change according to its speed of rotation. Specifically, the maximum allowable torque is maintained constant up to a certain speed, but the allowable torque drops above a certain speed. When the robot is operated in a velocity range including a low-torque zone as above with a constant acceleration/deceleration rate throughout the acceleration/deceleration period, such torque-lowering characteristic in the high-velocity range would greatly affect the robot operation, causing the acceleration/deceleration rate to be set unnecessarily low even in the low-velocity range. Therefore, our design allows the acceleration/deceleration rate setting to be independently adjustable for low- and high-velocity zones within the same acceleration/deceleration period.

### 3. Functions for Better Usability

During an operation for robot teaching or program checking, the robot is often made to touch or hit an object. We have therefore introduced an impact detection function, which detects, without any additional sensor, that the robot has hit an object. This impact detection function continually calculates an estimated torque value based on the robot's equation of motion (1), and if the difference between the estimated torque and the actual torque exceeds a threshold value, a collision is judged to have occurred (Fig. 3). However, the friction force included in the equation of motion (1) varies according to the temperature. Consequently, to improve the estimation accuracy, the friction coefficient is identified online and used for calculating the equation of motion (1). Figure 4 shows an example of the improvement in accuracy in estimating the torque thanks to this friction estimation. The optimal threshold value also varies according to the intensity of the robot's action. The threshold level is thus changed in real time according to the operating condition of the robot.

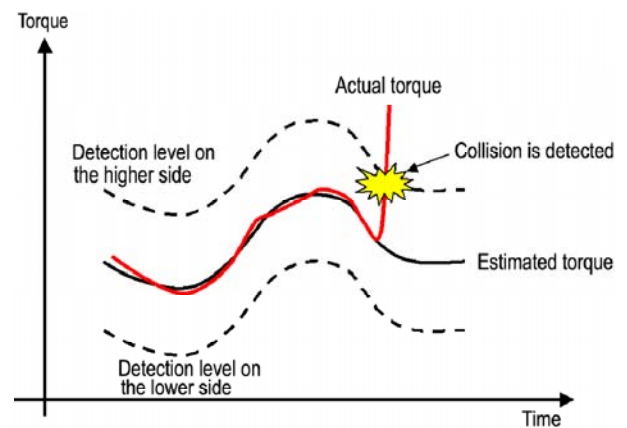


Fig. 3 Impact detection



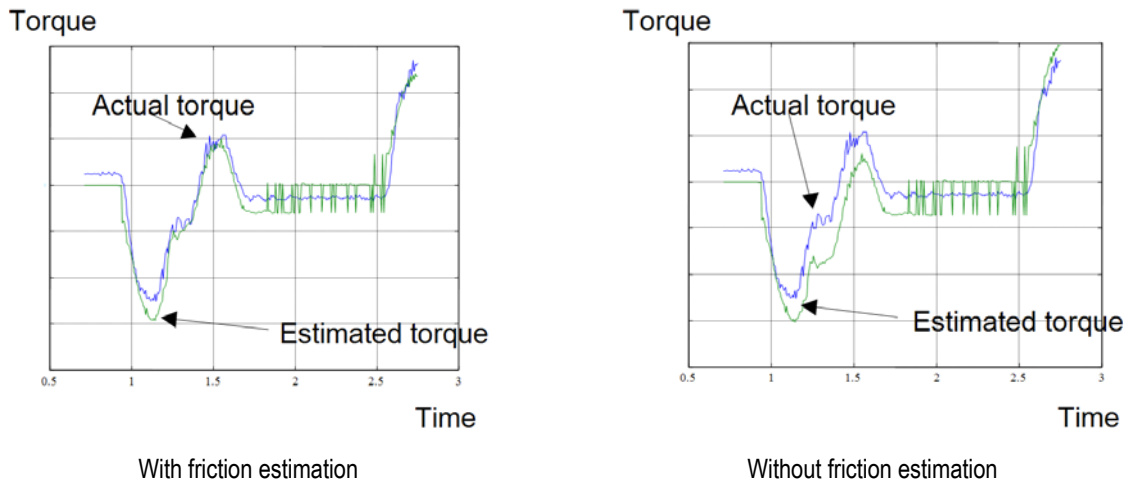


Fig. 4 Accuracy improvement of estimated torque by friction estimation

#### 4. Conclusion

We will continue research and development on robot functions for improving the velocity and accuracy, which constitute the basic performance of robots. We will also improve the usability functions to make robots more user friendly. In addition to these general-purpose functions, requests for application-specific functions are growing. In particular, applied control of sensors, such as three-dimensional sensors, force sensors and vision sensors, will increase in importance.

# Development of MScCoating for Aircraft Engine Parts

Authors: Masahiro Okane\* and Akihiro Goto\*

Many aircraft engine manufacturers apply coatings such as welding, thermal spraying and metal plating to parts that require abrasion resistance. However, problems include the fact that thermal spraying and metal plating need masking, and welding is likely to cause deformation or cracks of the workpiece due to heat concentration in the workpiece. In addition, these tasks must be done manually by skilled operators and are difficult to automate. To resolve these issues, we have developed MScCoating technology, which forms an accurate coating of layers in the desired shape wherever required. This article describes our MScCoating technology and its application to aircraft engines.

## 1. Overview of MScCoating Technology

With this technology, a metal or ceramic coating layer is formed on the surface of the workpiece by generating pulse electric discharges between the workpiece and an electrode. The electrode acts as the source of the coating material, which is transferred to the workpiece by the electric discharge. Figure 1 shows the process of forming the MScCoating layer. The electrode is formed from powder material and is easily broken up. When a voltage is applied across the electrode and the workpiece which are facing each other, electric discharge occurs. The energy of this electric discharge pulse melts the electrode material and breaks it up into tiny fragments. The fragmented electrode material is then transferred to the workpiece, where it re-solidifies on the workpiece surface. This process is repeated about ten thousand times per second to form a coating layer.

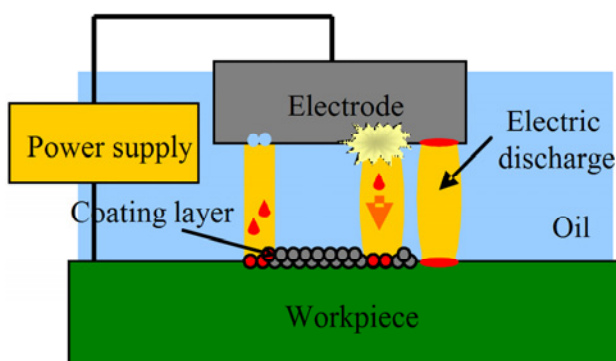


Fig. 1 Process of MScCoating

## 2. Features of MScCoating

The features of MScCoating are as follows:

- Strong bonding force between workpiece and coating layer, difficult to peel off
- Minimal heat-affected zone on workpiece, causing no cracks or distortion
- No masking required; coating layers of any shape can be formed anywhere
- Coating technology uses machinery, ensuring consistent quality of coating layer without relying on skilled technicians
- Adjustable electrode material and electric discharge pulse conditions, for forming various functional coating layers

## 3. Technologies Applicable to Aircraft Engines

An aircraft engine has many parts that require abrasion resistance under high-temperature conditions. This article reports an application of MScCoating technology to the interlocks of turbine blades. A turbine drives a compressor, whereby the energy of high-temperature and high-pressure gas generated in the combustor is converted into mechanical energy. As shown in Fig. 2, the turbine is structured such that adjacent blades are interlocked to form a circular shape. However, the blades are not bonded to each other and so grind against each other at the interlock and suffer wear while the engine is rotating. Conventionally, worn parts have been repaired by build-up welding, but this may cause excess thickness, and the heat may cause cracks or distortion of the workpiece.

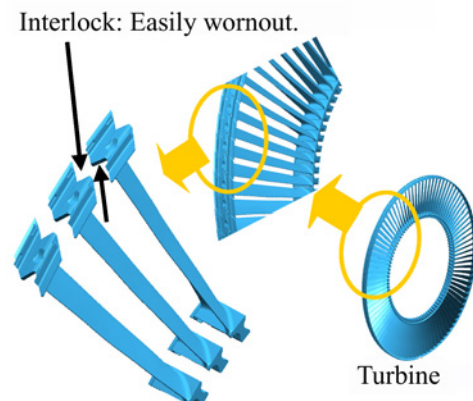


Fig. 2 Turbine blade

To resolve these issues, we have developed an MSCoating electrode composed of highly abrasion-resistant Co alloys. We conducted abrasion tests to evaluate the abrasion resistance of the coating layers formed under optimized conditions of electric discharge pulses. The tests were performed as shown in Fig. 3, where coating layers were formed either with build-up welding or MSCoating on the surface of a convex shaped workpiece of 5 mm in diameter and a cylindrical workpiece of 10 mm in diameter, which were then tested under the conditions listed in Table 1. When an aircraft engine is in operation, the temperature reaches nearly 1000°C, which necessitates evaluation over a wide temperature range from normal temperature to high temperature. The wear test result is shown in Fig. 4. In the case of build-up welding, severe wear was observed in the temperature range experienced while an aircraft is in cruise flight, i.e. from 350°C to 480°C, whereas the coating layer with MSCoating suffered almost no wear at any temperature, demonstrating high wear resistance. As indicated by these results, the newly developed MSCoating layers have high abrasion resistance and are expected to provide benefits including faster turbine blade repair and longer interval between inspections. In addition, the MSCoating does not cause cracks or distortion of the workpiece or generate excess thickness, and thus solves the issues of build-up welding such as excess thickness, and cracks and distortion of the workpiece.

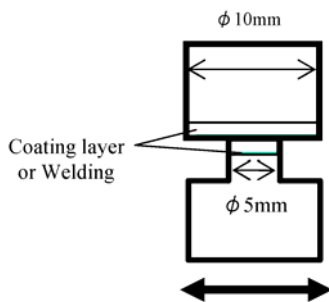


Fig. 3 Abrasion test model

Table 1 Abrasion test condition

Stroke length	0.5 mm
Test pressure	3 – 7 MPa
Frequency	40 Hz
Test temperature	<ul style="list-style-type: none"> <li>• Room temperature</li> <li>• 300°C</li> <li>• 480°C</li> <li>• 870 °C</li> <li>• 930°C</li> </ul>

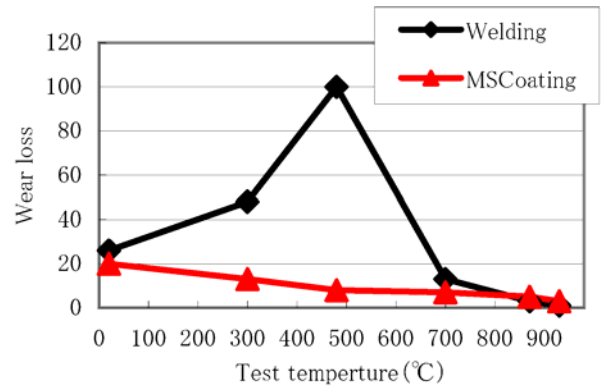


Fig. 4 Abrasion test result

#### 4. Future Direction

In October 2007, the MSCoating was certified by the Federal Aviation Administration (FAA) and approved for application to aircraft engines. In 2008, the first flight of an aircraft treated with MSCoating is scheduled to be held. We will continue with development work to expand the range of applicable aircraft engine parts as well as create various functional coating layers for automobiles, medical use and machine tools. Finally we thank Mr. Ochiai of IHI and many other people for their cooperation in the development and application of this technology.

#### References:

- (1) Hiroyuki Teramoto, Akihiro Goto, Kazushi Nakamura, Masahiro Okane, Ken Araki, Hiroyuki Ochiai, Mitsutoshi Watanabe: Development of Coating Technology by Electrical Discharge, Proceedings of JSPE Semester Meeting Vol. 2005S (2005) pp. 825-825
- (2) Masahiro Okane, Kazushi Nakamura, Akihiro Goto, Hiroyuki Teramoto: Development of Coating Technology "MSCoating" Using Electric Discharge, Proceedings of 2006 Conference on Die and Mould Technology pp. 116-117

# High Quality Hard Metal Machining System, “ASC”

Authors: Yoji Nakajima\* and Shuichiro Ishihara\*

Mitsubishi Electric has developed a corrosion preventive technology called “high quality hard metal machining system (Aqua Surface Control: ASC).” The ASC system ensures corrosion-free hard metal die and mold machining even when it takes a long time, while taking advantage of the high machining speed of the wire-cut electric discharge machining (EDM) process using water as machining fluid. With this technology, the ion balance in the machining fluid is controlled to maintain steady conditions so that the surface of hard metal is passivated to prevent corrosion.

## 1. The Challenge of Hard Metal Machining

Hard metals are compound materials composed of Group IVa, Va or VIa metal carbides of the periodic table and sintered with iron group metals (Fe, Co, Ni). Among others, WC-Co composed of tungsten carbide (WC) bound by cobalt is widely used. However, WC-Co is susceptible to corrosion when immersed in machining fluid (water) because corrosion-susceptible Co dissolves out. In addition, when wire-cut EDM is applied to hard metals, a work-affected layer is created on the machined surface. These are potential sources of chipping or cracks of hard metal dies and molds, affecting their service life.

Mitsubishi Electric has already developed a corrosion preventive system (PAM), which enables the machining of hard metal dies and molds without creating any corrosion layer or deteriorating the quality of the dies and molds even after immersing the hard metal in machining fluid for 24 hours. Mitsubishi has also developed an anti-electrolysis power supply (AE power supply) and super fine-finish power supply (FS power supply), which allow the work-affected layers and corrosion layers to be removed during hard metal machining.

Figure 1 shows the effect of PAM. After hard metal pieces finished with a FS power supply have been immersed in machining fluid for 24 or 96 hours, the pieces without PAM are corroded while those with PAM are not corroded after 24 hours.

Meanwhile, as the dies and molds used for IC lead frames, etc. are miniaturized and require higher precision, hard metals are immersed and processed in machining fluid for over 24 hours and so are likely to suffer corrosion due to the longer time required for the wire-cut EDM process. For example, across a weekend,

machined works may be left immersed in machining fluid for 96 hours. As shown in Fig. 1, the effect of PAM deteriorates in 96 hours. In addition, PAM is an electric corrosion prevention method as shown in Fig. 2, and so the corrosion preventive effect is reduced in the area away from the electrode, resulting in a limited corrosion preventive range.

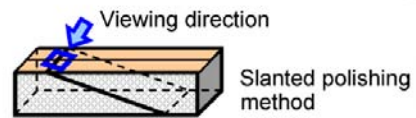
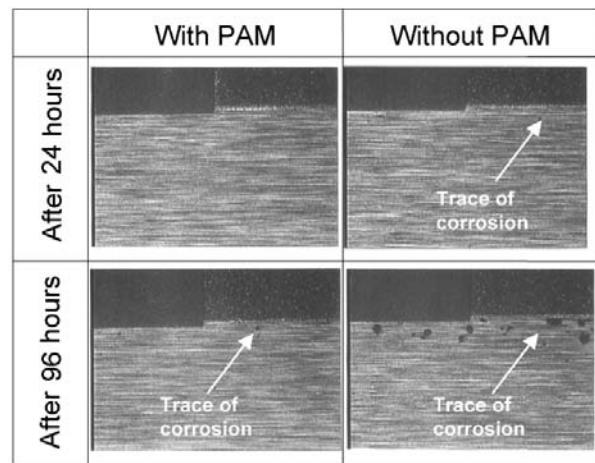


Fig. 1 PAM test results

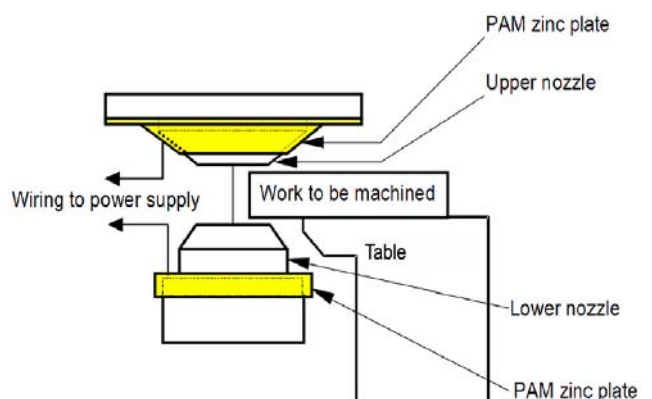


Fig. 2 PAM schematic illustration

With this background, we developed a high quality hard metal machining system to prevent the corrosion of hard metals in the entire machining range for the machining time of 96 hours (4 days).

\*Nagoya Works

## 2. Overview of the ASC System

In our high quality hard metal machining (ASC) system, the ion balance in the machining fluid is maintained in steady conditions so that the surface of the hard metal is passivated to prevent Co, which is a cause of corrosion, from dissolving out. The conventional wire-cut EDM apparatus uses water that has passed through ion exchange resin to control the specific resistance value at about 100,000  $\Omega$ -cm, while the ASC system is configured as shown in Fig. 3, where the supply of machining fluid to the ASC resin (specialized ion exchange resin) is automatically controlled with a sensor and controller for maintaining a steady ion balance.

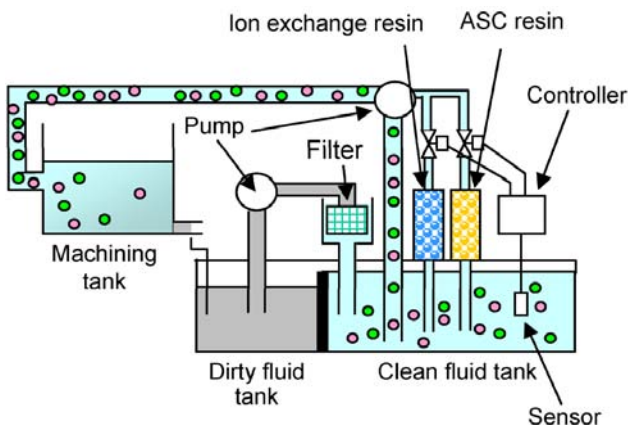


Fig. 3 ASC configuration

## 3. Features of the ASC System

- (1) Corrosion preventive effect against prolonged water immersion
  - Corrosion is prevented by controlling the machining fluid so that the ion balance is maintained in steady conditions to passivate the surface of hard metal.
  - Corrosion is prevented in the entire machining range.
- (2) Significant improvement in productivity
  - High-speed and high-quality machining without micro cracks, taking advantage of water based machining in combination with an anti-electrolysis power supply (AE power supply)
  - Reduction of process time by eliminating the time for removing the corrosion layer
  - The fire defense law is not applicable, allowing unmanned operation of multiple machines day and night, and easy implementation of an automated system.
- (3) Easy process control
  - Automatic control of machining fluid conditions eliminates concerns about the concentration, as opposed to anti-corrosion agents.

## 4. Benefits of the ASC System

Figure 4 shows the benefit of the ASC system after hard metal pieces are immersed in machining fluid for 96 hours. With the standard system, traces of corrosion are observed and WC dropped out due to the dissolving of the binder element of Co, whereas no WC dropped out from the test piece immersed in machining fluid with the ion balance controlled by the ASC system, thus confirming the corrosion prevention effect.

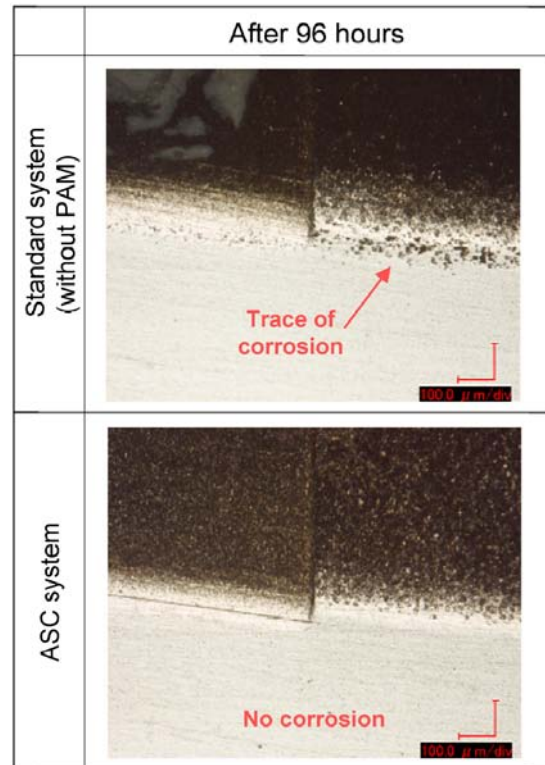
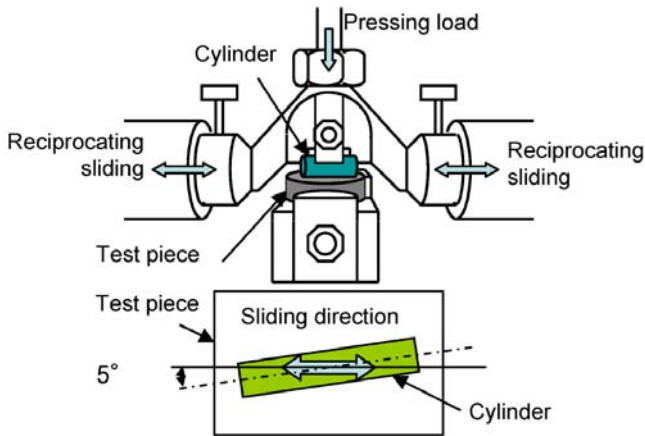


Fig. 4 ASC test results

To simulate the use of hard metal as a die or mold, after hard metal pieces had been immersed in various machining fluids for 96 hours, frictional wear tests were conducted on the EDM finished surface. Figure 5 shows the friction wear test configuration, where a cylindrical material is sliding against an EDM finished surface of the hard metal test piece. The test results are shown in Fig. 6. On the test piece machined with standard machining fluid, an apparent dropout of WC is observed, whereas no dropout is observed when using the ion-balance-controlled fluid and ASC system, confirming that the wear resistance is not deteriorated and the quality remains equivalent to that of the test piece machined in corrosion-free machining oil.

These test results suggest that the ASC system provides corrosion-free and high-quality machining of dies and molds, even when the hard metal machining takes a long time, and also offers high-speed machining using water (pure water) as machining fluid.



### 5. Vision for the Future

We have developed a high quality hard metal machining system for hard metals. We will continue to work on expanding the range of applications to the iron group materials generally used for dies and molds.

#### Testing conditions

- Dimensions of cylinder:  $\phi 15 \times L22$
- Hardness of side surface of cylinder: HRC61
- Load: 28N
- Stroke:  $0.85 \pm 0.05\text{mm}$
- Frequency: 5Hz
- Lubrication: None (Degreased with acetone)
- Test duration: 5 hours (Equivalent to 180,000 shots)
- Test piece: Hard metal material (Equivalent to JIS V40)
- Roughness of machined surface:  $1.0 \mu\text{mRz}$

Fig. 5 Frictional wear test method

Machining fluid	Standard (Pure water)	ASC	Oil
Surface condition			
Cross-sectional profile			

Fig. 6 Frictional wear test results

# CO<sub>2</sub> Laser Processing System “ML3015NX-60CF-R”

Authors: Kazuo Sugihara\* and Takashi Inoue\*

## 1. Introduction

Laser processing systems are now widely used for large lot productions, creating rapidly increasing demand for a “keep on running” capability while maintaining consistent processing performance. This demand is increasing the need for preventive maintenance technologies that prevent unexpected machine shutdowns as well as technologies that enhance machine reliability.

In response to these market requirements, we have developed the ML3015NX-60CF-R, which is equipped with a 6-kW output laser oscillator (Fig. 1). This machine was developed with the concepts of: (1) High performance (improved processing capability), (2) Keep on running (continuous operation), and (3) Think about less thing (improved operability). Details of each development concept will be described in the following sections.

## 2. High Performance

### 2.1 Improvement of cutting speed and processable thickness

Higher-speed cutting of a wide range of work materials has been achieved by the combination of: a new type of CO<sub>2</sub> laser oscillator, the ML60CF-R, which satisfies the requirements for high output for high-speed processing and high beam quality for high-quality proc-

essing; a beam stabilizer that generates uniform beam intensity over the entire processing area; a beam optimizer that controls the beam diameter and focus position to the best conditions for each material to be processed; and a two-dimensional laser processing system, the NX series, equipped with high-speed driving linear motors. About 1.5 times higher productivity is achieved for a wide range of work materials including mild steel (JIS SS400), stainless steel (JIS SUS304), and aluminum alloy (JIS A5052) (compared to Mitsubishi’s ML3015NX-40CF-R). For stainless steel (SUS 304, 1 mm thickness) in particular, the world’s highest speed of 30 m/min is possible.

In addition, laser processing allows a greater cutting thickness by increasing the output of the laser oscillator. The ML3015NX-60CF-R produces a maximum output of 6 kW, enabling a significant increase in cutting thickness compared to conventional laser processing systems. Its nominal processing capacity is 25 mm for mild steel, 15 mm for aluminum alloy, and 25 mm, which is a major increase from 14 mm for the widely marketable non-oxidized cutting of stainless steel.

Figure 2 shows examples of cutting various materials using a 6-kW oscillator.



Fig. 1 ML3015NX-60CF-R

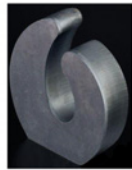
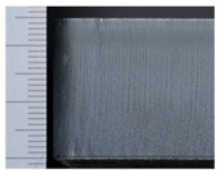

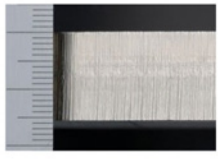

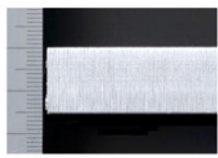
Material	Plate thickness	Cut sample	Cutting surface
Mild steel (SS400)	25mm		
Stainless steel (SUS304)	16mm		
Aluminum alloy (A5052)	15mm		

Fig. 2 Processing ability of the ML3015NX-60CF-R

### 2.2 Improved quality of cutting surface

The ML60CF-R CO<sub>2</sub> laser oscillator has a new power supply and new control method, which significantly improves the profile of the rectangular wave brilliant high peak pulse, which is a feature of 3-axis cross gas flow, by 50% from the conventional CF series (Fig. 3). In addition, the new system offers high-quality stainless-steel brilliant cut, thanks to an optimal beam path design that makes full use of the beam characteristics; an appropriately designed processing nozzle; and development of processing technology.

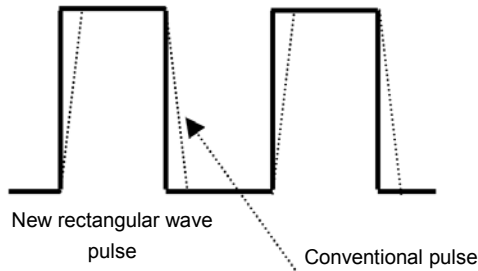


Fig. 3 Rectangular wave high peak pulse by new power supply

Figure 4 shows the roughness Rz of the cutting surface with the conventional method and the brilliant cut. The surface roughness Rz with brilliant cut is reduced to about 40 to 50% compared with the conventional method on both the upper and lower sides. The amount of taper is also reduced to about one-third of that by conventional cutting.

### 3. Improved “Keep on Running” Performance

The ML60CF-R CO<sub>2</sub> laser oscillator installed with the NX series system improves productivity by a high cooling mirror holder that can mitigate the thermal lens effect and hence generate a uniform beam for a long time, as well as newly developed clean technology that thoroughly eliminates the dust from the oscillator’s inner structural materials to improve the cleanliness by a factor of five in the vacuum zone between optical mir-

rors, thus extending the maintenance interval for optical components. Other technologies for achieving long-term stability include measures for high dust-proofness and high rigidity.

The processing system comes with a pallet changer as standard, and a sheet position detector to compensate the tilt and misalignment when changing the workpiece. These functions extended to the laser cell system in combination with an automatic material feeder enable long-time continuous processing. Even when consecutively processing different kinds of materials, the control unit automatically sets up process conditions based on the database, such as the focus point of the laser beam and the assist gas pressure, allowing continuous operation without manual setups.

In addition, a self-check function has been developed for monitoring the conditions of the mirrors in the oscillator and the sensitivity of the capacitance sensor to indicate the timing at which to replace parts. This function enables the user to develop a maintenance plan in advance and thus reduce machine down-time.

### 4. Think About Less Thing

The controller comes with a high-speed CPU and a 15-inch large-screen LCD display mounted with a touch-panel. The graphical user interface, tab representation, the use of icons, etc. is standardized among NC related products (Laser Processing Systems, Electrical Discharge Machines, and NC), and the drawing performance for on-screen diagnostic function, etc. is also improved, thus raising operability.

In addition, traditional guidance functions such as trial processing and help functions are enhanced, which makes it easier to change the operating parameters according to the processing conditions and to ensure optimal processing regardless of the operator’s skill level.

The processing strokes are 3,200 × 1,600 mm, which are about 5% greater than the standard dimensions of steel plate, 3,050 × 1,525 mm. These strokes ensure good workability when placing a material and

	Photograph of cutting surface	Surface roughness Rz (μm)	
		Upper surface	Lower surface
Conventional method		18	25
Brilliant cut		8	12

Fig. 4 Cutting surface by brilliant cut



allow the processing of special-size materials such as untrimmed materials, and so reduce the running cost by improving the material yield.

## **5. Conclusion**

The key features and processing capability of the NX series, the latest two-dimensional laser processing system, were described.

As an comprehensive manufacturer of laser processing systems, we will continue to improve system performance and proactively respond to various needs from the production floors including the automotive and electric industries.

# Laser Drilling System ML605GTW II-5150U

Authors: *Mitsuhiro Kaneda\** and *Toshiyuki Hokodate\**

## 1. Introduction

Since the mid 1990s, build-up technology has accelerated the spread of high-density, high-definition, thin-substrate printed circuit boards (PCB), thus contributing to the development of cellular phones and other electronic devices. Laser drilling used with the build-up technology is considered the standard method and a vital process for making through holes in each layer of a PCB. In response to various PCB requirements, the PCB laser drilling system has been continuously improved in the last 10 years. For better mechanical and electrical characteristics, PCBs are becoming more sophisticated in structure and material, but this makes it harder to raise productivity and quality in the drilling process. To solve these issues, we have developed the ML605GTW II-5150U laser drilling system (called "GTW II"). This article introduces the features of GTW II.

## 2. Features and New Technologies of GTW II

The GTW II inherits the twin-head, twin-work schemes of our conventional ML605GTW-5150U machine (called "GTW"), whereby two boards on the left and right tables are simultaneously processed using simultaneous two-beam spectroscopy. In addition, new technology is introduced for higher productivity. Figure 1 shows the appearance and the following sections describe the key features of GTW II.

### 2.1 High productivity

Mitsubishi Electric's PCB laser drilling system employs a digitally controlled galvano system for high-speed, high-precision laser drilling. The digitally controlled galvano system consists of three key components: a special control unit for high-speed galvano control, an amplifier, and a galvano scanner driven at high speed. By improving all key components of the



Fig. 1 ML605GTW-II - 5150U

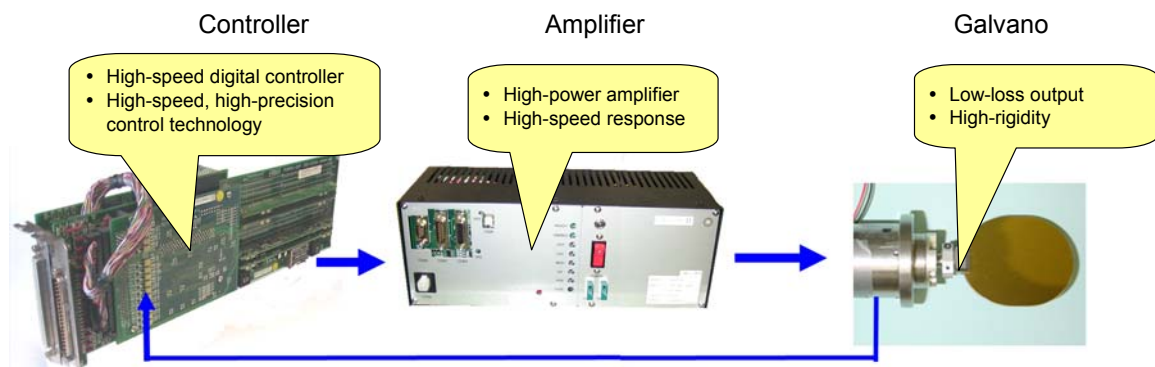


Fig. 2 Components of digitally controlled galvano system

galvano system as shown in Fig. 2, the GTW II offers high precision and dramatically faster galvano processing. In addition, the conventional 5150U CO<sub>2</sub> laser oscillator, which was developed in-house, has been improved to operate stably at a high pulse repetition rate up to 10 kHz, thus reducing the laser irradiation time for burst processing that irradiates multiple laser pulses consecutively onto the same hole.

As a result of improving the digitally controlled galvano system in terms of galvano speed and reducing the laser irradiation time by increasing the laser oscillator frequency to 10 kHz, the GTW II has achieved industry-leading productivity of about 3000 holes/sec, which is about 30% faster than our conventional model GTW (Fig. 3).

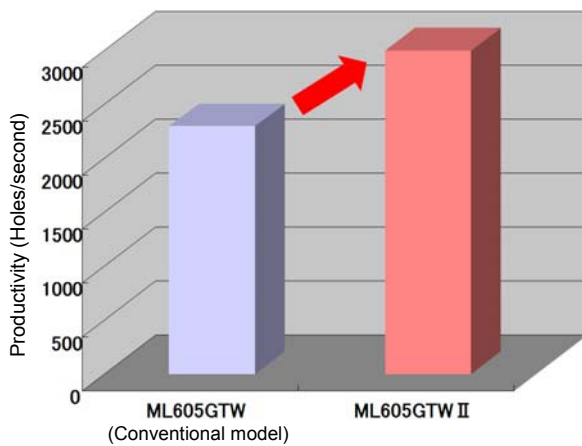
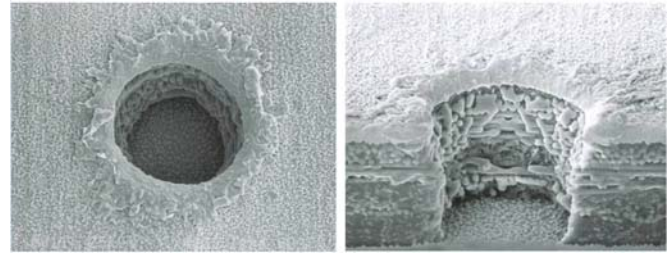


Fig. 3 Improvement in the productivity (in comparison with previous machine)

### 2.2 High-quality processing

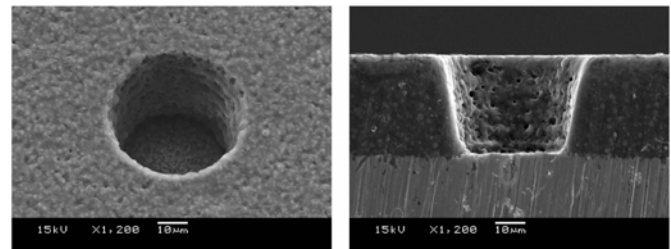
To increase the performance and lower the cost of PCBs, there is growing demand for direct processing of copper. The newly developed GTW II offers stable copper direct processing. Figure 4 shows an example of copper direct processing with the GTW II, in which irradiation of a laser beam having a high peak power is considered ideal for stable penetration of the surface copper foil. Mitsubishi Electric's unique laser oscillation technology enables its 5150U CO<sub>2</sub> laser oscillator to generate two kinds of pulses: a high-peak short pulse and a low-peak long pulse, allowing copper direct processing to be performed with ideal high-peak short pulses. In addition, the combination of these two kinds of pulses provides high-quality copper direct processing as shown in Fig. 4, where high-peak short pulses ensure stable penetration of the surface copper foil and then the laser pulse is instantaneously switched to the low-peak long pulse mode. Furthermore, for environmental reasons, PCB substrates are increasingly made of resin materials that are halogen free, and new materials are emerging with many fillers added to improve the mechanical characteristics. These trends of new

resin design make laser processing more difficult. In particular, a package PCB that needs fine drilling imposes very severe requirements on the laser processing. In response, the GTW II uses the high-performance fθ lens which was developed in-house and gives superior focusing performance. As a result, stable and high-quality laser processing has been achieved even for fine holes with a 50-μm diameter on the new materials of package PCB applications that used to be problematic for laser processing (Fig. 5).



Glass-epoxy resin bonded with copper foil  
Hole diameter 120 μm

Fig. 4 Copper direct drilling



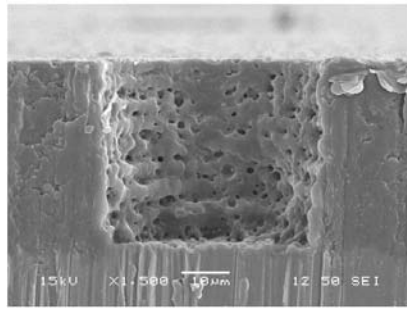
Epoxy type resin with filler Hole diameter 50 μm

Fig. 5 Micro drilling of new package material

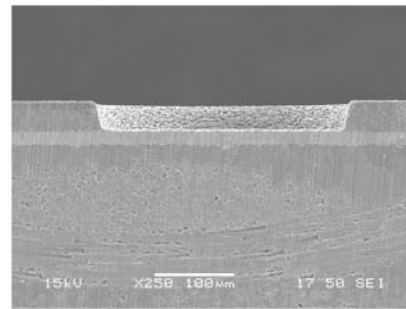
The GTW II also inherits the laser processing capability that satisfies various requirements from small to large diameters. Some of those applications are shown in Fig. 6.

### 3. Conclusion

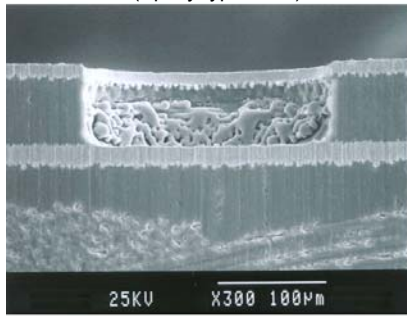
The newly developed ML605GTW II-5150U PCB laser drilling system offers high productivity and high-quality processing. The new method of PCB manufacturing is leading to innovative PCB design rule and mounting technology, and the emergence of more sophisticated and convenient electronic devices. Laser drilling applied to the PCB manufacturing process has had similar impact, and over 10 years have already passed since it was first used for mass production. PCB design will likely shift rapidly toward higher-density, higher-definition and thinner substrates; applications of laser processing will expand; and various new requirements will emerge. To meet such needs and contribute to the progress of mounting technology, we will continue to develop new laser processing systems.



φ50-µm small diameter drilling  
(Epoxy type resin)



φ350-µm large diameter drilling  
(Epoxy type resin)



φ200-µm conformal processing  
(Glass-epoxy resin)



φ100-µm large window processing  
(Glass-epoxy resin)

Fig. 6 Application example

