

Mar.2011 / Vol.133

MITSUBISHI ELECTRIC

ADVANCE

Latest Low-Voltage Circuit Breakers

• **Editorial-Chief**

Kiyoshi Takakuwa

• **Editorial Advisors**

*Masujima Toshio
Kanae Ishida
Tetsuya Mano
Tetsuji Sorita
Hiroaki Kawachi
Masayuki Masuda
Takahiro Nishikawa
Tetsuyuki Yanase
Ichiro Fujii
Taizo Kittaka
Keiji Hatanaka
Daisuke Kawai
Hideyuki Ichiyama
Toshitaka Aoyagi*

• **Vol. 133 Feature Articles Editor**

Toshio Komori

• **Editorial Inquiries**

*Tetsuya Mano
Corporate Total Productivity Management
& Environmental Programs
Fax +81-3-3218-2465*

• **Product Inquiries**

*Hitoshi Namba
AC Drives & LVS Systems Section
Overseas Marketing Department
Fax +81-3-3218-6820*

Mitsubishi Electric Advance is published on line quarterly by Mitsubishi Electric Corporation.
Copyright © 2011 by Mitsubishi Electric Corporation; all rights reserved.
Printed in Japan.

CONTENTS

Technical Reports

Overview	1
by <i>Hideyasu Nonaka</i>	
Features of Low-Voltage Circuit Breaker "WS-V Series"	2
by <i>Susumu Takahashi</i>	
Standardization and Value Analysis for Molded Case Circuit Breaker	6
by <i>Masahiro Fushimi and Takeshi Kurosaki</i>	
Evolution of Electronic-Hybrid Type Circuit Breaker and MDU Breaker	9
by <i>Toshimitsu Nomura and Haruhiko Yamazaki</i>	
High-Performance Current-Limiting Technologies for "WS-V Series" Using Double-Break System	12
by <i>Kentaro Kokura</i>	

Overview



Author: *Hideyasu Nonaka**

"Monozukuri" and "Easy to Use"

In response to globalization and the changing social environment, manufacturers are increasingly required to focus on improving production value and coexisting with the environment and society. To address these requirements, in the field of "Monozukuri (manufacturing)", each company strives to produce better products more quickly and with lower cost, improve capacity utilization, flexibly manufacture variable quantities of different products, ensure product safety, conserve energy, and take other measures to reduce environmental load.

Amid the backdrop of increasing globalization and the drastically changing social and natural environments, each manufacturer must achieve easy, friendly and comfortable "Monozukuri". For "Monozukuri" in the future, "easy to use" is essential: easy operation to reduce stress for users; superior energy-saving performance to be eco-friendly; good engineering design and services; and functionality that embodies the knowledge and skill of the shop floor, a unique Japanese characteristic.

As a comprehensive supplier of factory automation products, Mitsubishi Electric has proposed the concept of "e-F@ctory", which seeks to improve the production value of plants by providing various control devices, and to create a "visible" plant by linking them. In addition, to achieve harmonious coexistence with the environment and society, Mitsubishi Electric is now promoting the "e&eco-F@ctory" campaign, which strives to offer easy-to-use solutions for the world's leading plants.

Features of Low-Voltage Circuit Breaker “WS-V Series”

Author: *Susumu Takahashi**

1. Introduction

As the demand for electric energy increases and thus the capacities of facilities also increase, there is a need to increase the short-circuit breaking capacity, reduce the size for the same performance, increase the ampacity for the same dimensions, and increase the breaking capacity of molded case circuit breakers (MCCBs) and earth leakage circuit breakers (ELCBs), which are widely used for low-voltage distribution facilities and various machinery.

Meanwhile, when designing semiconductor fabrication equipment and machinery, high priority is placed on the layout of the main functional parts and the power source unit is made as compact as possible, and so compact MCCBs and ELCBs are required. In addition, the range of selection and interchangeability of cassette-type accessories are important criteria when selecting specific products.

In response to these needs, the new “WS-V Series” offers new F-Style compact models, higher ampacity and breaking capacity while keeping dimensional and installation compatibility with the previous series, and standardized accessories are interchangeable among various models. This paper presents the technologies and features of the new WS-V Series.

2. Arc-Driven Breaking Method

As the size of machinery becomes smaller, the size of the circuit breaker, which is one of the built-in parts, is also required to be smaller. The arc-driven breaking method is a space-saving technology and provides superior current-limiting performance. Mitsubishi Electric has already adopted this technology for the miniature circuit breaker (MCB) series. The arc-driven breaking method is now employed for 54 mm-width three-pole MCCBs.

The WS-V series is the first in the industry to use arc-driven breaking technology for MCCBs. For three-phase interruption, the switching mechanism achieves high-speed arc movement and three-pole quick-make/quick-break operation. A short-circuit breaking capacity of 10 kA (415 V) is achieved with the industry’s smallest dimensions of 54 mm width, 100 mm height and 68 mm depth (Fig. 1). The MCB has a switching mechanism for each pole, whereas the MCCB of the WS-V series has a single switching mechanism, which occupies the space for only one pole,

and links the three poles together using a cross-bar. The WS-V series also offers an ELCB product lineup in the same size and cassette-type accessories.



Fig. 1 NV32-SVF

3. Thermal-Magnetic Tripping for All Models in the Series

In the previous series, the 32A and 63A frames employed a hydraulic-magnetic type overcurrent tripping device. It is now modified to the thermal-magnetic type, and all frames from 32A to 250A have either a thermal-magnetic type or an electronic-hybrid type tripping device. These tripping devices are robust against current distortion, and thus reduce the chance of nuisance tripping.

In addition, the new 32A and 63A frames have a wider range of operating conditions commonly used for both DC and AC applications, making it easier to select a model.

4. Expanded ISTAC

In order to maintain the compatibility of installation and connection with previous models, the circuit breakers used in switchgears and switchboards must offer enhanced short-circuit breaking capacity in the same size, rather than being made smaller.

The Impulsive Slot Type Accelerator (ISTAC) is Mitsubishi’s original current-breaking technology that combines the electromagnetic force derived from the current path and the gas pressure generated from the insulation material caused by the arc at the time of interruption. The ISTAC has been adopted in the Progressive Super Series (PSS) launched in 1995. In the WS Series launched in 2001, this technology evolved into the Advanced ISTAC, which has an optimized

current path and an additional magnetic core to increase the breaking capacity. In the new WS-V Series, it has further evolved into the Expanded ISTAC, which is equipped with an extended repulsive current path as a result of combining the technologies and analytical techniques based on previous experience. The Expanded ISTAC technology is employed in high-performance models and has even greater breaking capacity (Fig. 2).

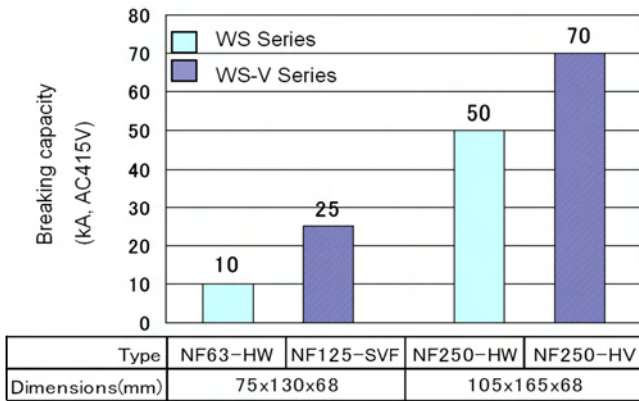

Fig. 2 Rise in breaking capacity by Expanded ISTAC

5. Double-Break System

Until now, ultra breakers have been used when an even higher short-circuit breaking capacity is required in a large-capacity power distribution system for a big building project. The ultra breaker is configured with a normal main circuit breaker and an additional current-limiting unit connected in series to the main breaker. The current-limiting unit is equipped with single-pole double-break type repulsive parallel conductors. This unit, together with the main breaker, provides a single-pole triple-break series interruption to generate a high arc voltage, resulting in superior current-limiting performance to suppress the short-circuit current.

For the WS-V Series, we have developed a new ultra breaker, which employs an internal double-break

system without using an additional current-limiting unit. The new smaller ultra breaker is the same size as the standard type, and improves interchangeability of accessories and standardization of switchboard design (Fig. 3).

6. Evolution of Electronic-Hybrid Type Circuit Breaker

The electronic-hybrid type circuit breaker has advantages of high performance and diverse functionality including overload and short-circuit protection and adjustable ampere rating.

In addition to the functions of conventional electronic-hybrid type circuit breakers, the 125A and 250A frames of the WS-V Series have an optional display for indicating current values, thus reducing space without requiring additional wiring, and improving workability compared with the conventional setup for measurement using a separate ammeter and current transformer (CT) (Fig. 4).

The new Measuring Display Unit (MDU) breaker (250A frame) also has an electronic-hybrid type breaker in the main body to improve performance further. The MDU breakers save energy by measuring, displaying and transmitting load current, line voltage, electric power, electric energy, and other electric circuit data, and are ideal for line monitoring and preventive maintenance of facilities. In addition, the size of the earth leakage and leakage alarm breakers is reduced to the same size as the MCCB, also contributing to space-saving, standardization of switchboard design and common use of accessories.

7. Common Use of Accessories

Internal accessories for the WS Series were designed as user-installable cassette type and prepared for each frame, resulting in a complicated system with many different types of parts.

For the WS-V Series, cassette-type accessories

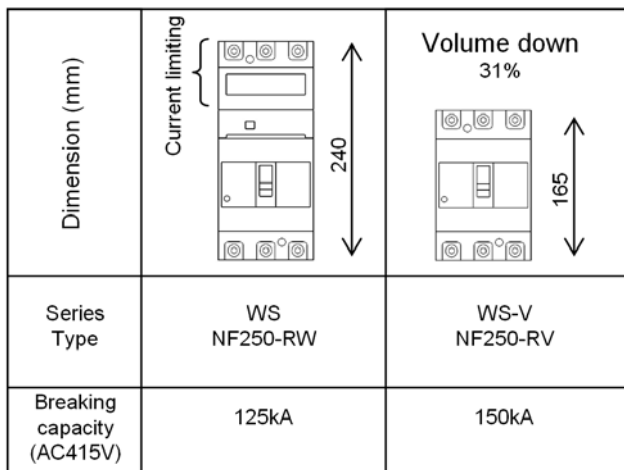

Fig. 3 Downsizing of ultra breaker by series-arc breaking



Fig. 4 Electronic circuit breaker with display

are interchangeable among all models from the 32A frame (75 mm width) to 250A frame (105 mm width) (Fig. 5). This feature has been achieved by developing a basic circuit-breaker platform, balanced design for satisfying the load relationship throughout the lineup from the smallest to the largest frames, and the associated production technology.

32,63A Frame	125A Frame	250A Frame
AL (1)	AL (2)	AL (3)
AX (1)	AX (2)	AX (3)
SHT (1)	SHT (2)	SHT (3)
UVT (1)	UVT (2)	UVT (3)

32 – 250A Frame
AL
AX
SHT
UVT

AL: Alarm switch
 AX: Auxiliary switch
 SHT: Voltage tripping device
 UVT: Undervoltage tripping device

Fig. 5 Commoditizing of cassette-type accessories

Thanks to interchangeable parts among various frames, the number of stocked units and lead time to shipment can be reduced. Other improvements from the WS Series include the aggregation of modular systems into two groups: F-Style small 63A frame and all other frames; the ELCB also equipped with an optional Shunt (Voltage) Tripping (SHT) device; and the 250A frame Undervoltage Tripping (UVT) device added as one of the cassette-type accessories. These features greatly enhance convenience for users.

8. Automated Robot Cell Assembling

In addition to the features of specifications, the production technology for the WS-V Series has been improved. From the planning and development stage, we have focused on automation and laborsaving, particularly by robot cell assembling. In the design of mechanical parts ranging from 75 to 105 mm-width models, the following measures were taken into consideration:

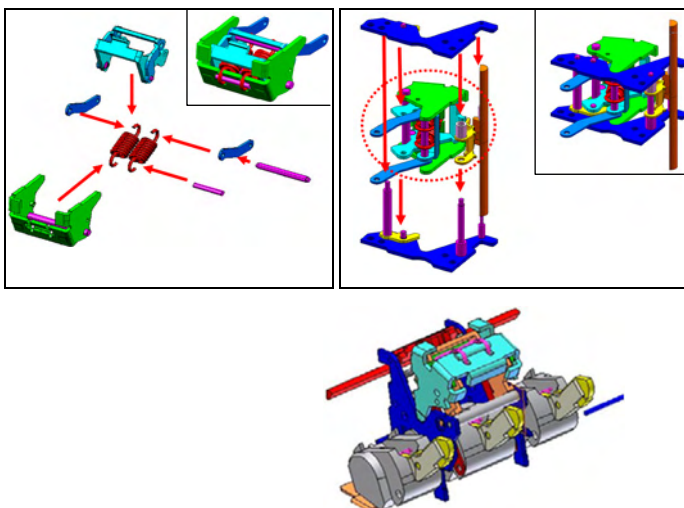

Fig. 6 Mechanical parts for robot cell assembler

- (1) Utmost common use and shape standardization of parts among various models
 Contribution to fewer robot hands and positioning fixtures
 - (2) Extensive use of inset connection and mating guide
 Takt time improvement by faster assembling speed and prevention of short interruptions
 - (3) Reduction in urging force of the spring being assembled by optimized positioning
 Prevention of deformation and extension of service life for the equipment and work to be assembled
- With these measures, a fully automated robotic assembly system has been established from parts supply to final assembly. (Fig. 6)

9. Series Model Lineup

Figure 7 shows the typical model names listed by size and by frame, to highlight the position of the F-Style. Only standard S-type MCCBs are shown as representatives. The new F-Style compact models are identified by the suffix "F".

In the same way as the WS-Series, the new series complies with various overseas standards to assist the global export of machinery and switchboards. The Chinese GB Standards, revised in June 2009, have made it mandatory for the ELCB to use a three-phase power source. Quick action was taken to ensure the WS-V Series comply with this revised requirement. (Table 1)

Table 2 shows the model lineup of the WS-V Series, which offers a wide selection range for various applications including: F-Style compact models for machinery and industrial control panels; increased short-circuit breaking capacity while keeping the same size for switchgears and switchboards; and additional functionality of the electronic-hybrid type circuit breaker such as alarm, measurement and communication capability.

Although the MCCB and ELCB have long histories and the market is already mature, we are continuing to improve them to meet various market requests by developing and applying new technologies and methods and by improving the material, production and analysis technologies. We remain committed to meeting various market needs in product development.

Frame	32	63	125	250
Dimensions				
54 mm width (54 × 199 × 68)	NF32-SVF	NF63-SVF		
75 mm width (75 × 130 × 68)	NF32-SV	NF63-SV	NF-125-SVF	
90 mm width (90 × 130 × 68)			NF-125-SV	
105 mm width (105 × 165 × 68)				NF250-SV NF250-SEV

Outline of previous type
 F-Style

Fig. 7 Outline dimensions and ampere frames

Table 1 Conformance with main standards



Standards	IEC	EN	GB	JIS
	International	Europe	China	Japan
				
MCCB	●	●	●	●
ELCB	●	●	●	●

Table 2 List of WS-V Series

Class \ Frame		32	63	125	250
		MCCB	NF-C		NF63-CVF NF63-CV
NF-S	NF32-SVF NF32-SV		NF63-SVF NF63-SV	NF125-SVF NF125-SV NF125-SEV	NF250-SV NF250-SEV
NF-H			NF63-HV	NF125-HV NF125-HEV	NF250-HV NF250-HEV
NF-R				NF125-RV	NF250-RV
NF-U					NF250-UV
ELCB	NV-C		NV63-CVF NV63-CV	NV125-CVF NV125-CV	NV250-CV
	NV-S	NV32-SVF NV32-SV	NV63-SVF NV63-SV	NV125-SVF NV125-SV NV125-SEV	NV250-SV NV250-SEV
	NV-H		NV63-HV	NV125-HV NV125-HEV	NV250-HV NV250-HEV

Standardization and Value Analysis for Molded Case Circuit Breaker

Authors: Masahiro Fushimi* and Takeshi Kurosaki*

1. Introduction

The "WS-V Series" new molded case circuit breaker (MCCB) and earth leakage circuit breaker (ELCB) lineup introduces the new F-Style small models for machinery, and offers interchangeable outer dimensions and improved interrupting performance while maintaining one rank higher ampacity for use in switchgears and switchboards (Table 1). This paper describes the features of the "WS-V Series" in terms of standardization and value analysis (VA).

2. Standardization of Outer Dimensions and Employed Technologies

The Expanded Impulsive Slot-Type Accelerator (ISTAC) technology is used in the 'S' and 'H' class models having a width ranging from 75 to 105 mm (Fig. 1). Compared with the structure of the conventional ISTAC, the new stationary contact holder has an extended lower conductor (the part shown in Fig. 1

through which current B flows) to greatly enhance the repulsive force exerted on the moving contact arm at the time of a short-circuit interruption. With this structure, the torque and acceleration speed for opening the contact are doubled from those of the previous design, and the maximum peak current during interruption is reduced by 10%. As a result, the following performances have been achieved:

- (1) New lineup of 'S' class, 75 mm width, 125A frame models. The breaking capacity of the 250A frame is greatly increased.
 - (2) The characteristic of $I_{cu} = I_{cs}$ is achieved for all 'S' class models (I_{cu} and I_{cs} : Performance guaranteed for two and three consecutive breaking operations, respectively).
 - (3) One rank higher ampacity for 'H' class models (Previously unavailable rated current for 125 A with 90 mm width; 250 A with 105 mm width).
- In addition, the new interruption technology, re-

Table 1 WS-V Series specifications

MCCB lineup except for Ultra breaker

Frame A	32				63				125				250																											
Class	C		S		H		R		C		S		H		R																									
For machine (F Style)	7.5/7.5		7.5/7.5		15/15		—		30/15		50/50		—		—		36/27	85/85	100/100	150/150																				
	54*100*68								75*130*68								105*165*68																							
For switchboard	7.5/7.5		7.5/7.5		15/15		25/19		30/15		50/50		100/75		150/150		105*165*68																							
	75*130*68								90*130*68								105*165*68																							
WS series (Former type)	7.5/4		7.5/4		15/8		25/13		30/15		50/25		100/50		125/125		35/18		50/25		100/25		125/125																	
	75*130*68								90*130*68								90*191*68								105*165*68								105*240*68							

Upper column: Short-circuit breaking capacities I_{cu}/I_{cs} (kA) at 230VAC, Lower column: Overall dimensions width*length*height (mm) (3-pole models)

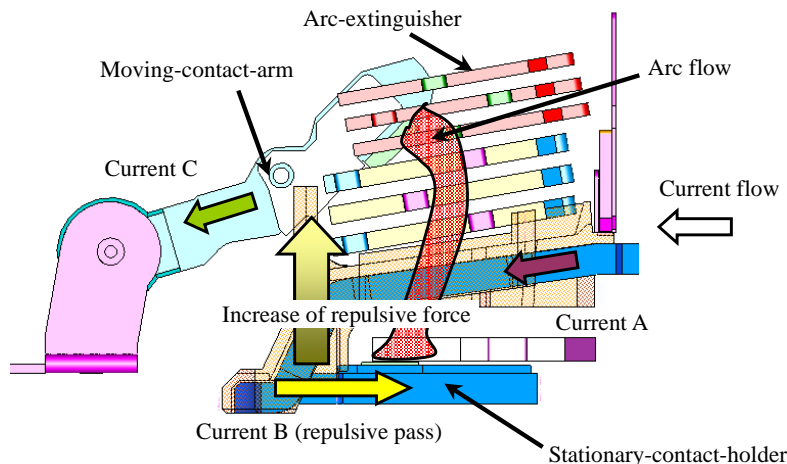

Fig. 1 Model of expanded ISTAC

ferred to as the blowout type double-break mechanism, is employed in the 'R' class models to achieve a breaking capacity of AC 415 V / 150 kA with the same outer dimensions as those of class 'C' of the 250A frame.

Some of the main functions of the switching mechanism in the circuit breaker include: to interlock the handle and the moving contact arm, to open the moving contact arm at a high speed in response to the activation of a tripping device when an overcurrent occurs, and to push the contacts against each other with appropriate force to prevent abnormal heat generation or poor contact while a current passes through. The requirements to satisfy these functions depend on the rated current, breaking capacity, etc., and hence the design of the conventional switching mechanism is totally different for each size group. In order for the WS-V Series to standardize the switching mechanism among three different size groups of 75 mm, 90 mm and 105 mm width models, the design was newly optimized to standardize the parts and side view layout (Fig. 2). As a result, the 75 mm and 90 mm width models are now completely compatible and 50% of the parts are the same as used for the 105 mm width model.

3. VA by Downsizing

The new F-Style lineup of products, which are smaller than conventional products, for machinery and industrial control panels has been added to the WS-V Series (32/63A frame and 125A frame). The width of the 32A and 63A frames is reduced to 54 mm (Fig. 3), resulting in a smaller product with less usage of plastics such as base and cover materials, as well as metal materials such as for current-path conductors and

contacts.

The 54 mm width models use the arc-driven breaking technology, which has been used in miniature circuit breakers (MCBs) for reducing the width. In the arc-driven breaking mechanism, arc-extinguishing grids are placed away from the contacts and the arc is quickly separated from the contacts, resulting in less wear of the contacts. To apply this system to the MCCB and ELCB, the grid design and the shape of the commutation runner and exhaust port, all of which are important points when using the arc-driven breaking mechanism, have been optimized by detailed simulation using fluid analysis and electromagnetic analysis. Compared with the previous products, the arc-driven breaking technology has almost doubled the 3-time breaking capacity (Ics) while reducing the volume to 55%.

In the MCB that uses the arc-driven breaking system, each pole is equipped with a switching mechanism for opening/closing of contacts. Therefore, it is not feasible to install optional inner accessories, or standardize the outer dimensions between the MCCB and ELCB. To overcome this problem, while keeping the layout of the moving contact arm and stationary contact holder optimized for the arc-driven breaking system, multiple moving contact arms of all poles are interlocked to the single switch mechanism using a crossbar, in the same way as for the 75 mm width model (Fig. 4). In addition, the switching mechanism is configured as a two-stage tripping structure to satisfy the requirements of both instantaneous tripping activated by a plunger and long time-delay tripping via a bimetal element. This structure enables the adoption of the arc-driven break-

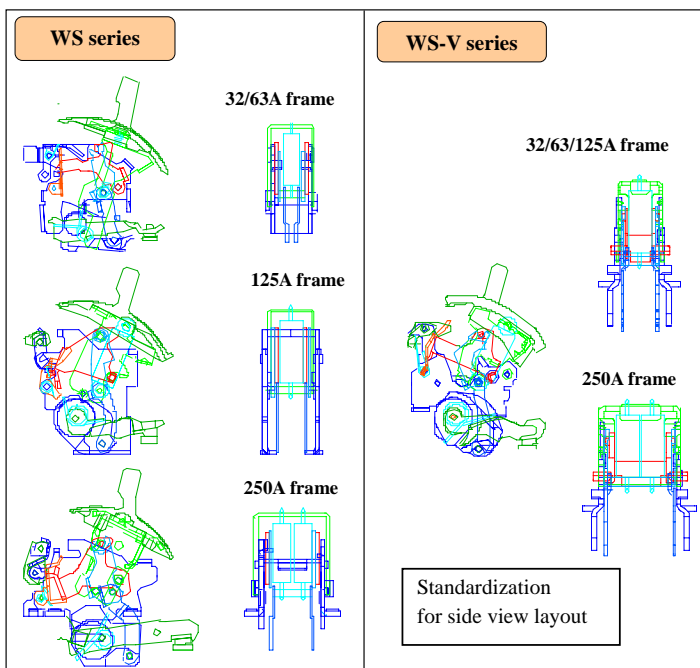

Fig. 2 Comparison of switching mechanisms

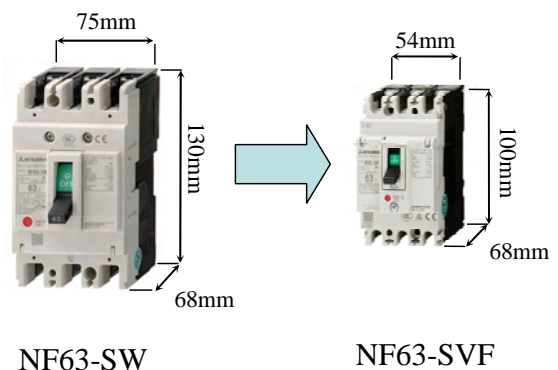

Fig. 3 F-Style MCCB of 54 mm width

ing system as well as the use of built-in accessories and size compatibility, which are indispensable features for the MCCB and ELCB lineup. The ELCB has a built-in electronic circuit to detect a leakage current using the signal from the zero-phase current transformer (ZCT). To provide power to this leakage detection circuit, the conventional model uses a harness, which is connected to the main circuit terminal by using crimp-type terminals and screws. In contrast, the new 54 mm width model provides power by making contact between the main circuit terminal and the leakage detection board by using a push spring. This configuration not only reduces the wiring space and power load area, but enables one-touch assembling of the leakage detection unit, thus significantly improving productivity.

4. Standardization of Internal Accessories

Internal accessories for the MCCB and ELCB are designed as user installable cassettes, so specifications can be easily modified and order placement is simplified. For the WS-V Series, cassette-type accessories are interchangeable among the 75 to 105 mm width models. This is more convenient for users by reducing both the lead time for shipment and the number of stocked units. Figure 5 shows the interchangeable cassette-type accessories for the 32A to 250A frame models. Features of the internal accessories for the WS-V Series are as follows:

- (1) New JIS, IEC and GB certifications have been obtained for the same unit.
- (2) Undervoltage tripping (UVT) device for the 250A frame is now one of the cassette-type accessories.

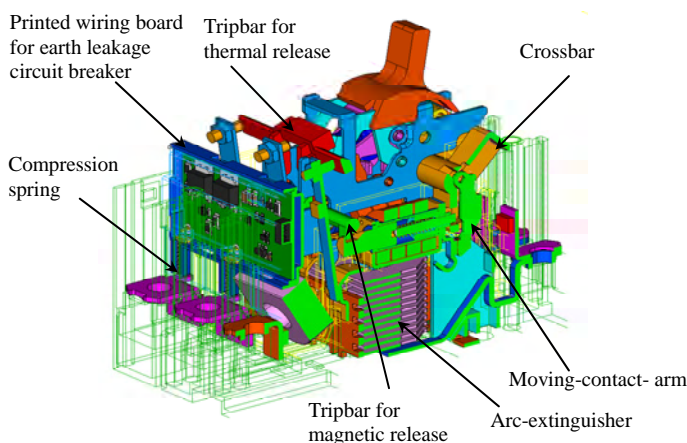

Fig. 4 Construction of F-Style MCCB of 54 mm width

- (3) ELCB is equipped with an optional shunt (voltage) tripping (SHT) device.

To achieve common use of the internal accessories among various frames of the WS-V Series, one of the challenges was to develop a tripping device that fits the smallest size of 75 mm width model, and also to drive the tripping load of the main unit for the maximum size of 105 mm width model.

The dimensions of the internal accessory space in the 75 mm width model are 18 mm (W) × 43 mm (L) × 30 mm (D), while the tripping load required for the switching mechanism of the 105 mm width model is about three times greater than that of the 75 mm width model. To generate a high tripping force within a limited volume, the following measures were taken:

- (1) Electromagnetic analysis to determine the method for improving magnetic characteristics.
- (2) Optimum structural design to reduce the required load.
- (3) Improved winding accuracy by using an NC winding machine.

In addition, cassette-type accessories have also been developed for the F-Style product lineup (54 mm width models), the industry's smallest 32A/63A frame products to be stored within a limited space, by making the accessories 20% smaller than those of the 75 mm width or larger models.

This paper has described the features of the new WS-V Series and its technologies in terms of standardization and value analysis. We will continue to develop products that meet customers' needs.

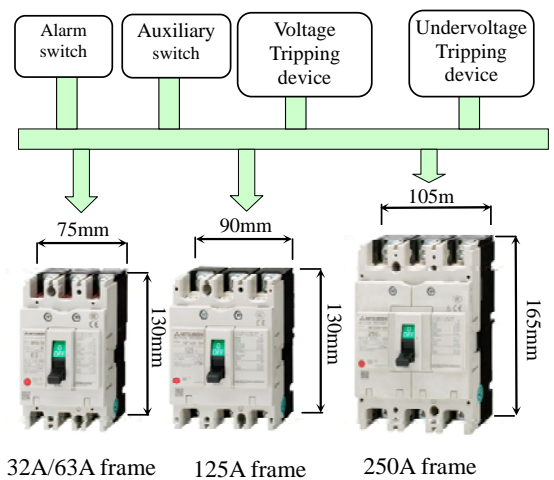

Fig. 5 Common use of internal accessories between different sizes of MCCB

Evolution of Electronic-Hybrid Type Circuit Breaker and MDU Breaker

Authors: *Toshimitsu Nomura** and *Haruhiko Yamazaki**

1. Introduction

Electronic-hybrid type circuit breakers deliver superior performance through multi-adjustable functions for both overload and short-circuit protection resulting in easily coordinated protection of electric circuits, and a pre-alarm function that enables predictive and preventive maintenance. However, demands are increasing for even higher performance and functionality, such as more detailed settings for protection parameters and alarm functions. Meanwhile, as energy conservation activities gain momentum, there is demand to reduce the size and increase the functionality of the measuring display unit (MDU) breaker, which has a built-in voltage transformer (VT) and current transformer (CT) and is able to monitor energy consumption in electric circuits, and which is compact and easy to install. To meet these requests, we have developed and commercialized the WS-V Series, which offers improved performance of electronic-hybrid type and MDU breakers. This paper describes the evolution of these breakers.

2. Overload and Short-Circuit Protection

Molded case circuit breakers are categorized as thermal-magnetic or electronic-hybrid type according to the mode of operation and tripping characteristics. The thermal-magnetic type operates in two tripping modes: long time-delay tripping and instantaneous tripping, and its characteristics are normally fixed. In contrast, the electronic-hybrid type has six adjustable characteristics, as shown in Fig. 1.

Due to their adjustable characteristics, the electronic-hybrid type circuit breaker has the following

advantages: (1) adjustable current setting makes it easy to increase the load current at the time of facilities enhancement (no need to replace circuit breakers); (2) easy coordination with the upper stream protective devices and lower stream load characteristics (especially, start-up rush current of generators and exciting rush current of transformers) ensure a continuous supply of electricity; and (3) pre-alarm function allows the operator to detect the load conditions and take preventive measures before the circuit breaker is activated for interruption to avoid power outage.

However, as facilities become more intelligent, protective coordination settings need to be improved and more detailed. Meanwhile, despite the convenience of adjustable current setting, products need to be simple as too many adjustable parameters are difficult to handle. In response to these conflicting market needs, the specifications for the WS-V Series were chosen as follows.

To simplify the setting parameters for overload and short-circuit protection, only two parameters are now adjustable on the circuit breaker (setting dials): (1) current setting, I_r ; and (2) instantaneous pick-up current, I_i (either fixed to 14 times the current setting (I_r) or variable from 2 to 14 times the rated current (I_n)), resulting in more simplified use. The external appearance of the WS-V Series electronic-hybrid type and its trip characteristics selector is shown in Fig. 2.

To enhance the setting features of tripping characteristics: (1) the setting for I_{6t} characteristics is added in the current range below about 160% of the current setting (I_r) (the setting for I_{2t} characteristics is also

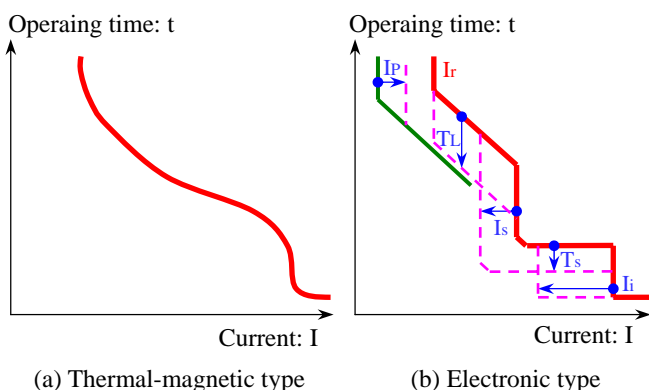

Fig. 1 Operating characteristics

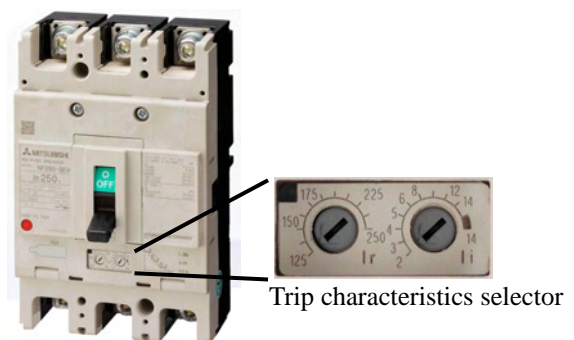

Fig. 2 WS-V Series electronic-hybrid type

selectable), and four types of current-limiting characteristics are now provided to prevent erroneous tripping due to temporary overload while charging uninterruptible power supplies (UPS); and (2) the characteristics can be set more flexibly by additional adjustable properties such as an additional setting value of 12 s (at 200%) for long time-delay operation to protect generators. Figure 3 shows an example of enhanced protection coordination by the addition of I^6t characteristics. These characteristics are adjustable from the display or by using a special-purpose breaker tester.

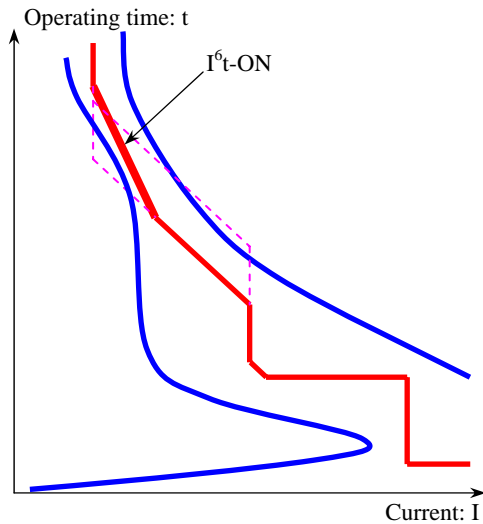

Fig. 3 Example of protection coordination

3. Measuring and Display Functions

The pre-alarm function has been installed for the predictive and preventive maintenance of facilities, where an alarm is generated when a load current exceeds a predetermined value. Additional market requirements are: (1) to grasp the margin from the setting value; and (2) to measure and display a load current for energy conservation. Consequently, an optional function of load current display has been added.

When circuit breakers are installed on a switchboard, holes are generally cut out of the face plate and then the breakers are attached to the plate so that the switch handle and the type name, rated current, etc. on the name plate are visible. To eliminate the need to cut too many holes, the LCD display is installed on the name plate so that measured values and alarm status are visible with only a few cutouts, thus saving space for measuring and displaying load current data.

Circuit breakers are generally installed in a relatively dark area such as on a switchboard in the switch room, and so a white LED backlight has been added to the LCD display to improve visibility. In addition, when an alarm occurs, the entire LCD display screen changes to a red color for better viewing, as shown in Fig. 4.

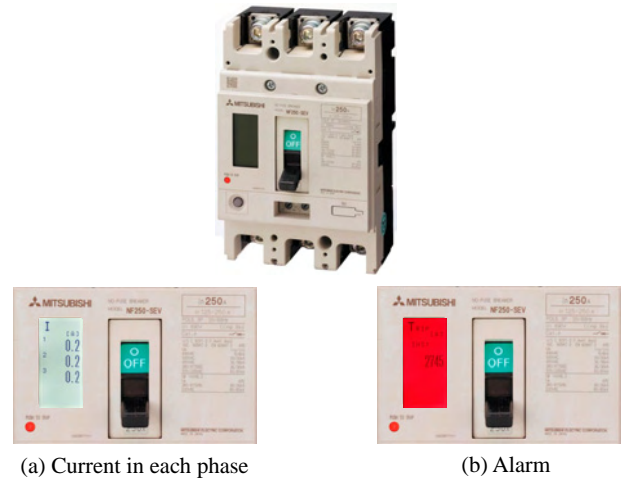

Fig. 4 WS-V Series NF250-SEV DP

4. New MDU Breaker

The MDU breaker has a built-in CT and VT to measure and display the load current, line voltage, electric power, electric energy, and other electric parameters. This type of breaker is popular for its three main advantages: (1) compactness and ease of installation; (2) higher performance and multiple functions; and (3) lower overall cost. However, as energy conservation activities are gaining momentum and the number of measuring points is increasing, we have been working to improve the performance while saving space and increasing measurement accuracy.

The WS Series MDU breaker has a thermal-magnetic type overload/short-circuit protection unit (250A or lower frame), and is equipped with a CT exclusively used for measuring a load current. We have developed a small, high-accuracy CT that can both detect an overload/short-circuit current and measure a load current, and have saved space by combining the two functions.

For overload/short circuit detection and protection, consideration must be given to: (1) the distortion of output waveform in the saturated area (because the sensor must function up to more than ten times the maximum rated current); and (2) the influence of magnetic fields generated by a large current flowing in other phases.

To satisfy these considerations efficiently, we have developed a new waveform analysis method by establishing a coupled analysis technique for governing equations (magnetic circuit and electric circuit). The high-accuracy CT has been realized by performing CAE analyses on the output waveform and characteristics to optimize them for given external dimensions, iron core materials and other input parameters.

The effects of this newly developed small, high-accuracy CT are described in the following sections.



Fig. 5 NF/NV250-SEV with MDU

Table 1 Measurement accuracy

		WS-V	W&WS
Measuring	Current	±1.0%	±2.5%
	Voltage	±1.0%	±2.5%
	Power (active)	±1.5%	±2.5%
	Power (reactive)	±2.5%	–
	Energy (active)	±2.0%	±2.5%
	Energy (reactive)	±2.5%	–
	Frequency	±2.5%	–

The ELCB needs storage space for a zero-phase current transformer (ZCT) for the detection of leakage current and a CT for measurement, and thus the MCCB and ELCB of the previous WS Series MDU breakers have different external shapes. In contrast, the small, high-accuracy CT frees up internal space and the same external shape and dimensions of both the MCCB and ELCB are realized (Fig. 5).

The ELCB occupies 30% less volume, and standardized mounting dimensions make it easier to design the switchboard, thus reducing total cost.

The small, high-accuracy CT has also improved the measurement accuracy of the WS-V Series MDU breakers, as shown in Table 1. In addition, the display is compact, and the WS-V Series MDU breaker has the LCD display on the name plate in the same way as an electronic-hybrid type breaker with the current indication function (panel mounting type with separate display and communication unit is also available).

The MDU breaker of the WS-Series no longer needs a measuring and display unit which used to be mounted on the main body of the breaker unit, saving space. It also reduces the hole cutting process on the face plate and allows easy installation. In addition, multiple measuring items can be simultaneously indicated (first, second and third phase currents are displayed together, etc.), which saves labor by less frequent switching of display items.

This paper has described the features of the WS-V Series electronic-hybrid type circuit breakers and MDU breakers. We will continue to develop products to meet customers' needs.

High-Performance Current-Limiting Technologies for “WS-V Series” Using Double-Break System

Author: Kentaro Kokura*

Increasingly sophisticated power distribution systems require improved protection performance, which in turn requires low-voltage circuit breakers with current-limiting performance to prevent fault currents. In response, Mitsubishi Electric has developed original single-break interruption technologies, striving to expand the range of products. These technologies include VJC⁽¹⁾ and ISTAC⁽²⁾, which use the rise in pressure generated in the arc extinguisher. We have now expanded the lineup of large-capacity models in pursuit of higher breaking performance (short-circuit breaking capacity / external size). In this project, in addition to the conventional technologies, we have adopted a double-break interruption system which can relatively easily reduce the moment of inertia of the moving contact arm; the arc-spot voltage drop is very high when the contacts are opened and so the breaking performance is directly improved.

For the NF125-RV and NF250-RV models of the WS-V Series, Mitsubishi Electric has developed a double-break interruption system employing the blowout coil method to achieve world-leading breaking performance (short-circuit breaking capacity / external size). This article describes the high-performance

current-limiting breaking technology employed in those models and the results of basic development studies.

1. High-Performance Current-Limiting Breaking Technology for Multiple Contact System

1.1 Structure of double-breaking arc extinguisher using blowout coil method

Figure 1 shows the internal structure of the new circuit breaker, which has a double-breaking arc extinguisher using the blowout coil method, and Fig. 2 shows the layout of the conductors inside the arc extinguisher. As shown in Fig. 2, the moving contact arm, which has an axis of rotation at the center and a movable contact on each end of the conductor, is held by the rotor, which is connected to the switching mechanism via a link pin. When the switching mechanism is manipulated, the link pin causes a rotating motion of the rotor and then the moving contact arm rotates anticlockwise in the figure to open the contacts. In contrast, when breaking a large current, such as when instantaneous tripping occurs, the moving contact arm alone moves in advance driven by electromagnetic

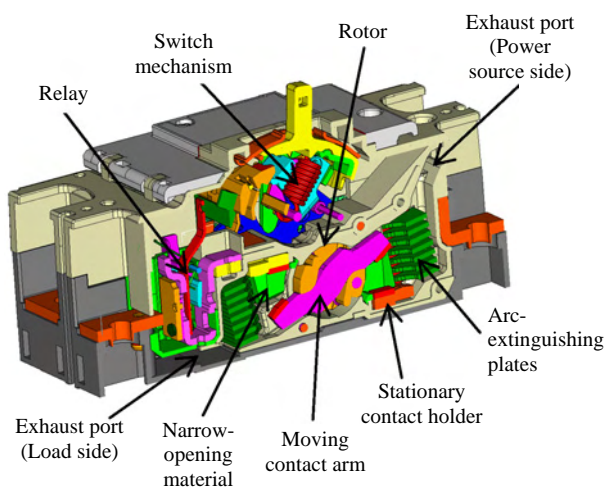

Fig. 1 Diagrammatic perspective view of MCCB applying double-breaking system

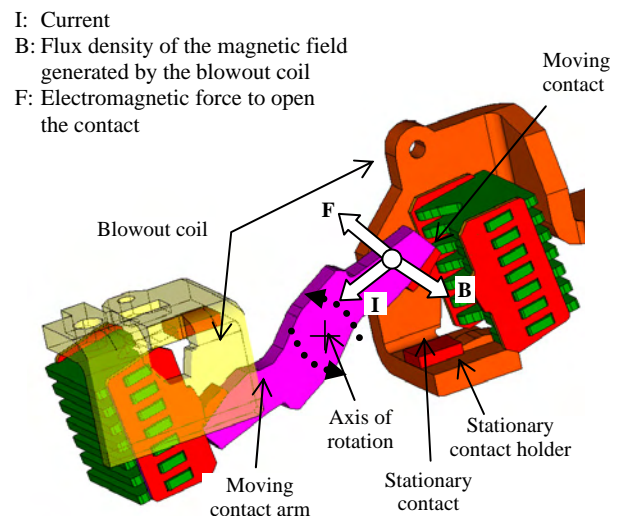

Fig. 2 Conductor structure of blowout coil method

force to open the contacts. This structure allows the moving contact arm to have a lower moment of inertia and speeds up the break operation. The stationary contact holder is positioned facing toward each end of the moving contact arm, and the stationary conductor is arranged along the side surface of the moving contact arm and forms a blowout coil. As a result, when a current passes through, the magnetic flux generated by the coil intersects perpendicularly with the conductor arm of the moving contact arm and exerts an electromagnetic force on the arm in the direction to open the contact. The combination of the reduced moment of inertia of the moving contact arm and the enhanced electromagnetic driving force further improves the speed of breaking. In addition, the magnetic flux from the blowout coil also intersects perpendicularly with the arc that occurs between the contacts at the time of interruption, and thus a driving force is exerted on the arc in the direction of the arc-extinguishing plates and the arc reaches the plates and breaks up at an early stage of the interruption, resulting in improved current-limiting performance. Note that the blowout coil on the power source side and the other one on the load side are placed alternately on each side of the moving contact arm to ensure sufficient volume for the arc-extinguishing plates. These measures reduce the wear of arc-extinguishing plates at the time of Ics and other large-current breaking (Ics: short-circuit breaking capacity guaranteed for three consecutive breaking operations). The blowout coils are placed alternately because the magnetic flux from each coil also exerts a force on the moving contact arm in the sideways direction, and such configuration cancels the forces exerted in the opposite direction with respect to the axis of rotation. The moving contact arm, stationary contact holders and other parts are protected by the unit case and are enclosed in the circuit breaker housing separate from the switching mechanism and relay.

When finalizing the blowout coil structure, alterna-

tive designs for the stationary conductor were compared. For each candidate structure, electromagnetic field analyses were carried out to calculate the acceleration speed of the moving contact arm when an interruption occurs. The current-limiting performance of the actual circuit was also verified using simplified real mockups. Details of these processes are described in Section 1.2.

1.2 Study on the structure of stationary contact holder to realize high-speed interruption

For high-speed interruption, it is important to increase the electromagnetic force that drives the moving contact arm in the direction to open the contacts. The strength of this electromagnetic driving force is mainly dependent on the layout of the stationary conductors. Therefore, magnetic field calculations were carried out to obtain the acceleration speed of the moving contact arm for each of the candidate stationary contact holders, which were considered to generate potentially high electromagnetic driving force. These calculations were performed using TOSCA, an electro- and magnetostatic field analysis software package. Table 1 shows the internal structure of typical models of the arc extinguisher, each of which has a different stationary conductor layout: (1) U-turn configuration (conventional structure), where the stationary conductor is turned back so that the moving contact arm is facing toward the repulsive current path; (2) blowout coil configuration, where the coil is placed along the side surface of the moving contact arm so that the generated magnetic field intersects perpendicularly with the moving contact arm; and (3) turn-back-and-up configuration, where the stationary contact holder is extended toward the center of the rotor and then turned back so that the moving contact arm comes close to the repulsive current path. Among these three types of conductor layouts, both the U-turn and turn-back-and-up types require the stationary conductor to be extended in the direction of the arc

Table 1 Analytical model of double-breaking-conductor structure (TOSCA, electro-/magnetostatic field analysis software)

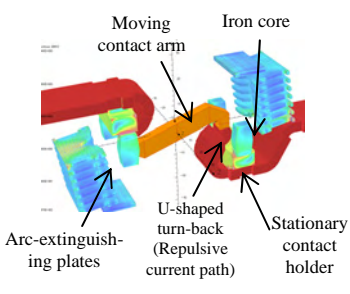
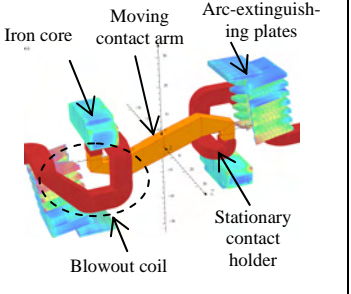
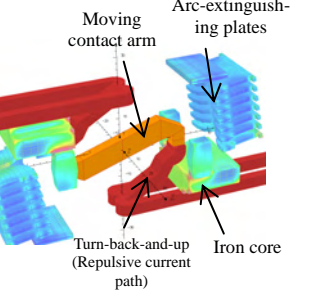
Name	(1) U-turn (Conventional structure)	(2) Blowout coil	(3) Turn-back-and-up
Layout of arc extinguisher			
Acceleration speed for interruption	1.0	1.16	1.12

extinguisher’s height, whereas in the blowout coil configuration, the conductor is extended in the direction perpendicular to the moving contact arm. Each of these models includes appropriately placed arc-extinguishing plates and a core near the contact, which affects the distribution of the internal magnetic field. Analyses on these models showed that the blowout coil and turn-back-and-up configurations improved the acceleration speed of the moving contact arm by about 10% over the U-turn configuration, indicating potential high-speed interruption performance.

1.3 Interruption Testing to Verify Current-Limiting Performance of Stationary Contact Holder

Simplified mockups were made and tested for each of the arc extinguisher models described in Section 1.2. Figure 3 shows the waveforms of the arc voltage, arc current, and pressure in the arc extinguisher during the interruption testing. Figure 4 compares the current-limiting performance, expressed as a percentage relative to the level of U-turn configuration as 100% (circuit conditions for interruption testing were single phase, 265 V 50 kA, and turn-on phase of 60°). Note that the simplified mockups have no switching mechanism to hold the moving contact arm. Therefore, the purpose of the testing was to verify the effect of suppressing the peak current due to a high-speed interruption, without considering the phenomena occurring after the peak current, which are greatly affected by the behavior of the mechanism and the arrangement of arc-extinguishing plates. With these points in mind, the following results were obtained from the interruption tests. The blowout coil type exhibited 5.5% better current-limiting performance over the U-turn configura-

tion, probably due to the longer arc due to the faster speed of the opening contact, because, as seen in Fig. 3, the dV/dt of the arc voltage increased after 2 ms. The pressure generated in the U-turn configuration is higher than that in the blowout coil and turn-back-and-up configurations. This result is attributed to the position of the narrow opening filled with a polymeric material. The material in the narrow opening melts and evaporates due to the heat of the arc. Consequently, it reduces the arc temperature and increases the pressure in the arc extinguisher, and thus the arc is compressed and the current-limiting performance is improved. Compared with the U-turn type, the generated pressure is lower in the blowout coil and turn-back-and-up configurations, where the narrow opening is arranged closer to the rotor and more distant from the contact position (on the opposite side of the arc-extinguishing plates). The lower pressure is likely caused by the greater distance between the narrow opening and the arc that is moving toward the arc-extinguishing plates. From these results, it is confirmed that the improved current-limiting performance of the blowout coil and turn-back-and-up types is derived from the high speed of the opening contact and is independent of the pressure. Combining the results described in this section and in 1.2, both the blowout coil and turn-back-and-up configurations have the potential to improve the current-limiting performance with a small increase in the pressure. For the new WS-V Series, the product specifications are required to satisfy both high current-limiting performance and small housing size. In the turn-back-and-up configuration, the repulsive current path must be arranged in the vertical direction with respect to the rotor. In contrast, the blowout coil configuration requires no space in the

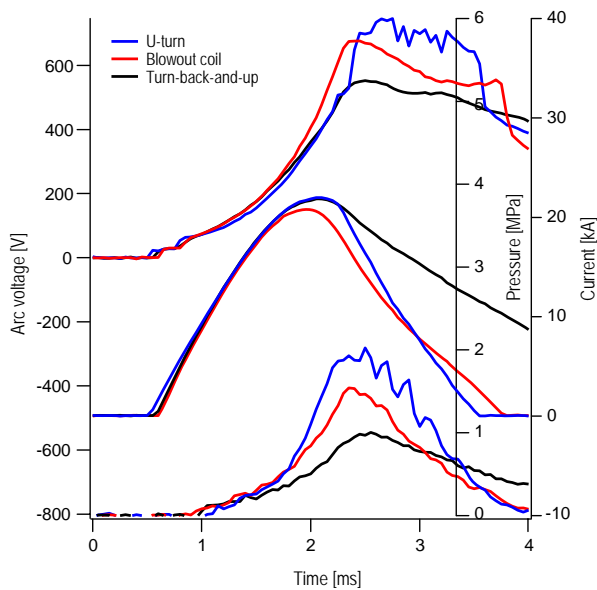

Fig. 3 Interruption characteristics of MCCB applying blowout coil method (Circuit conditions: Single phase, 265 V 50 kA, turn-on phase 60°)

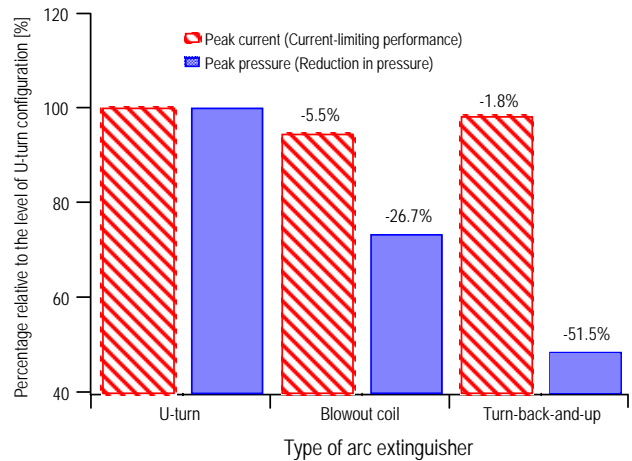

Fig. 4 Conductor structure of blowout coil method

direction of the arc extinguisher's height, and thus allows a smaller product than the turn-back-and-up type. We therefore used the blowout coil configuration for the new WS-V Series.

1.4 Verification of Breaking Performance of Three-Pole Models

Figure 5 shows an example of the interruption test result of the product as shown in Fig. 1 (circuit conditions: three-phase, 415 V \times 1.1, 150 kA). This chart shows only the arc voltage and current in the phase having the maximum current in the three-phase interruption, and indicates that the interruption was successfully completed within about 4.2 ms after the current was turned on. This result shows top-class interruption performance with the smaller housing.

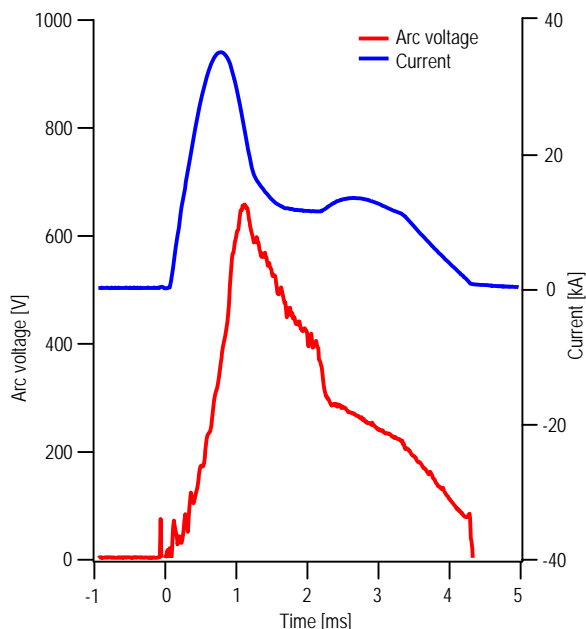

Fig. 5 Interrupting waveform of maximum-phase current in three-phase circuit interruption test (Circuit conditions: Three-phase, 415 V \times 1.1, 150 kA)

2. Conclusion

This paper described the structure of Mitsubishi Electric's first double-break type circuit breaker adopting the blowout coil method, which is installed in the NF125-RV and NF250-RV models of the new WS-V Series. It also described the development of the high-performance current-limiting technology to achieve the interruption performance of three-phase, 415 V and 150 kA. These technologies are suitable for higher-grade models requiring stricter circuit breaking with higher current-limiting performance. We will continue to apply these technologies to a wider range of products.

References

- (1) Hajime Yoshiyasu, et al.: Vapor-jet control (VJC): A new technique for current-limiting interruption, Mitsubishi Denki Giho, Vol. 60, No. 4, pp. 230–232 (1986)
- (2) Mitsugu Takahashi, et al.: ISTAC Breaker Technology for New Circuit Breakers and Earth Leakage Circuit Breakers, Mitsubishi Denki Giho, Vol. 69, No. 4, pp. 353–357 (1995)

