

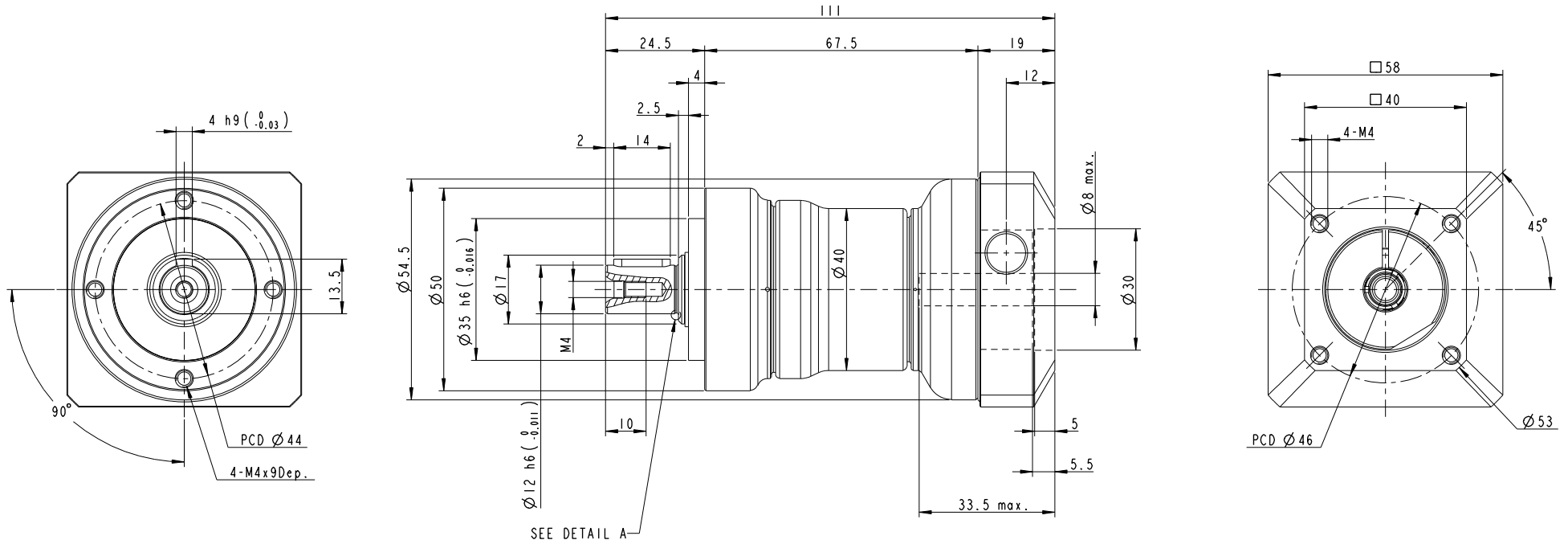

# PE II 050 - 020 / MITSUBISHI HG-KR13

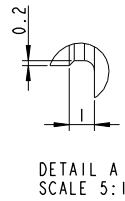

INERTIA: 0.1 ~ 0.11 kg-cm<sup>2</sup>  
 MASS: 0.7 Kg

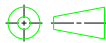

|  |      |  |              |
|--|------|--|--------------|
| PART NO.<br>PE2-050_2ST_8-P0411100304<br>AD-PE2-S8-M40-4 |      |  <b>APEX DYNAMICS, INC.</b> |              |
| APPROVALS  | DATE | TITLE<br>PE2-050_2 Stages_S8 , RATIO= 12-100<br>AND MOTOR FLANGE MOUNTING  |              |
| DRAWN<br>沈正巍   |      | DWG NO.<br>PE2-050_2ST_8-P0411100304   |              |
| CHECKED  |      |                             | SIZE<br>A3   |
| APPROVED   |      |  | SCALE<br>1:1 |
|  |      | REV  |              |