

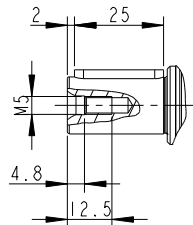

PE II 070 - 007 / MITSUBISHI HG-KR73

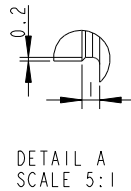
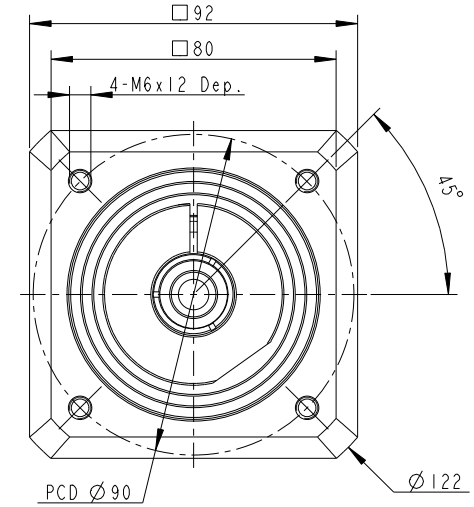
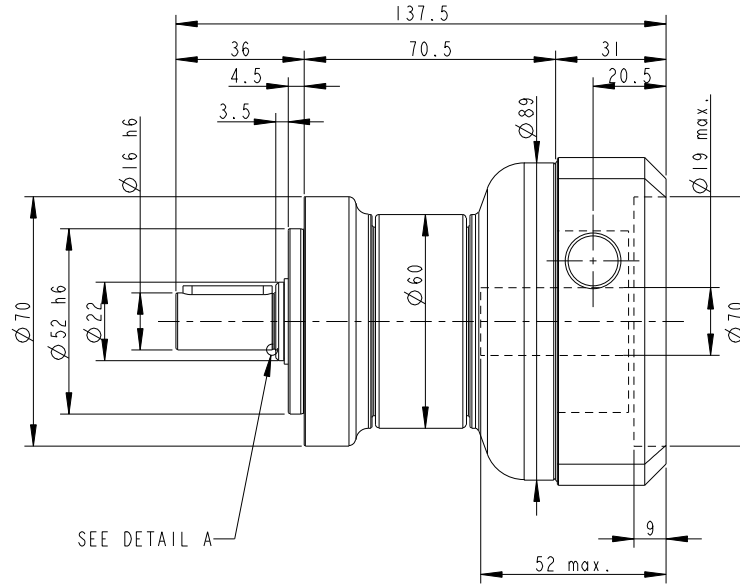
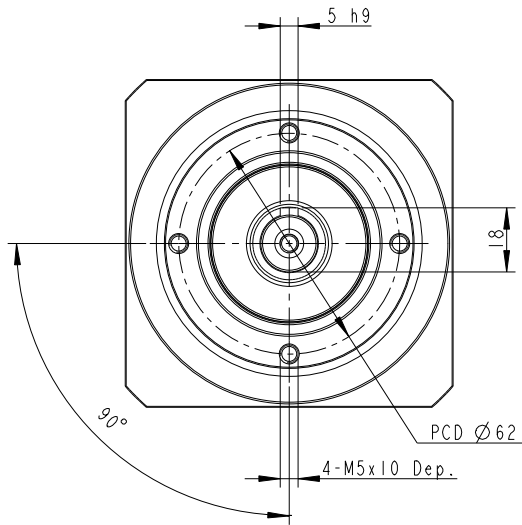
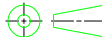

INERTIA: 1.51 ~ 1.54 kg-cm²
MASS: 1.9 Kg

PART NO. PE2-070-1ST-19-P0411400503 AD-PE2-S19-M80-3		 APEX DYNAMICS, INC.		
APPROVALS	DATE	TITLE PE2-070_1 Stage_S19 , RATIO= 3~10 AND MOTOR FLANGE MOUNTING		
DRAWN 沈正義		DWG NO. PE2-070-1ST-19-P0411400503		
CHECKED				
APPROVED		 SIZE A2	SCALE 1:1	REV