

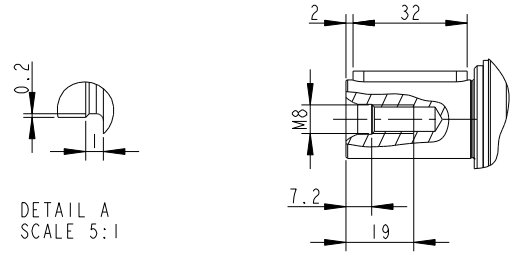

PE II 090 - 010 / MITSUBISHI HG-KR73

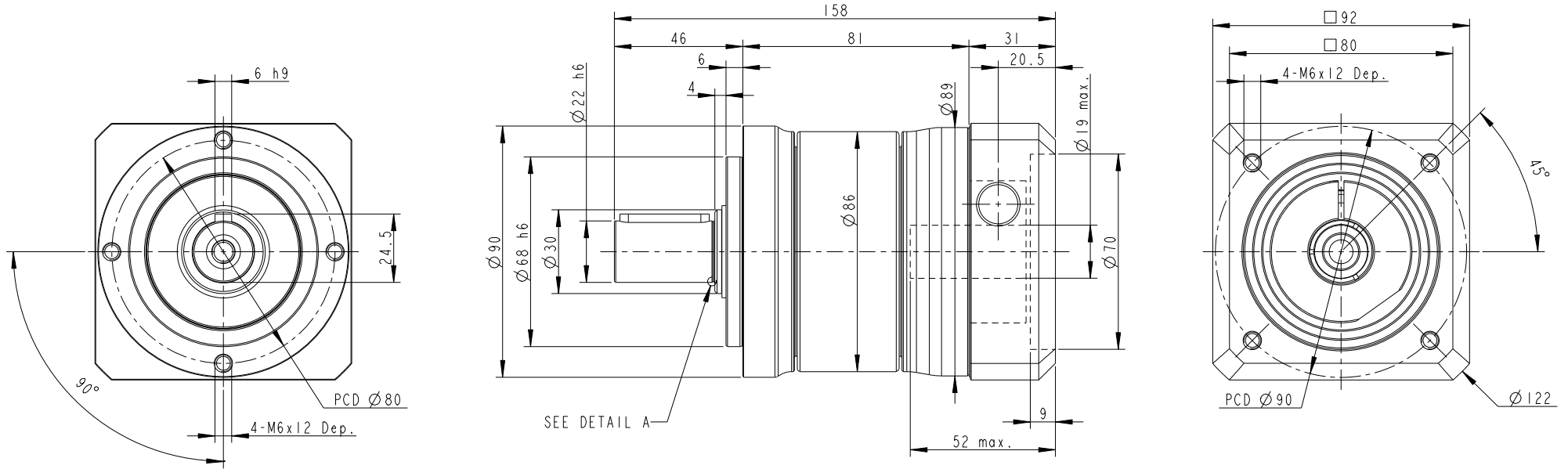

INERTIA: 1.63 ~ 1.77 kg-cm²
 MASS: 3 Kg

PART NO. PE2-090-1ST-19-P0411400503 AD-PE2-S19-M80-3		 APEX DYNAMICS, INC.		
APPROVALS	DATE	TITLE PE2-090_1 Stage_S19 , RATIO= 3~10 AND MOTOR FLANGE MOUNTING		
DRAWN 沈正義		DWG NO. PE2-090-1ST-19-P0411400503		
CHECKED				
APPROVED		 SIZE A2	SCALE 1:1	REV