

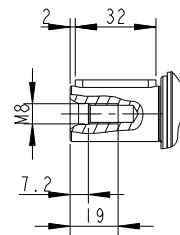

PE II 090 - 010 / MITSUBISHI HG-SR52

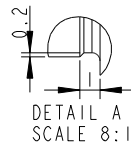
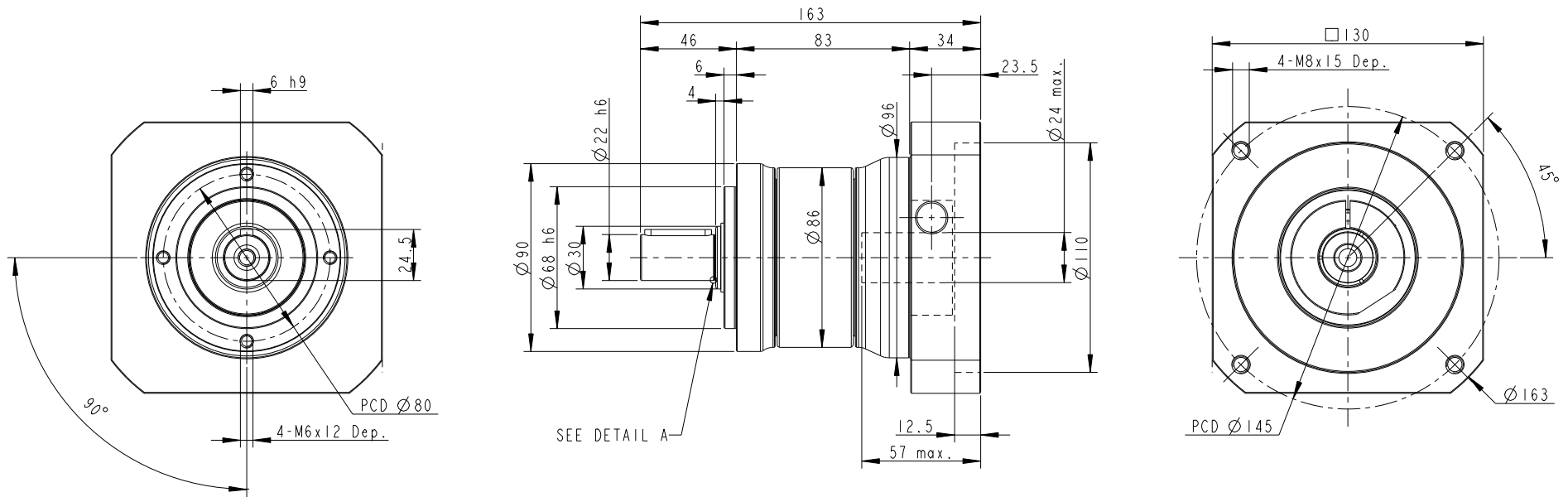

INERTIA: 2.19 ~ 2.33 kg-cm²
 MASS: 3.2 Kg

PART NO. PE2-090_1ST_24-P0411501607 AD-PE2-S24-M130-7		 APEX DYNAMICS, INC.	
APPROVALS	DATE	TITLE PE2-090_1 Stage_S24 , RATIO= 3-10 AND MOTOR FLANGE MOUNTING	
DRAWN 沈正義		DWG NO. PE2-090_1ST_24-P0411501607	
CHECKED			SIZE A1
APPROVED		SCALE 1:1	REV