

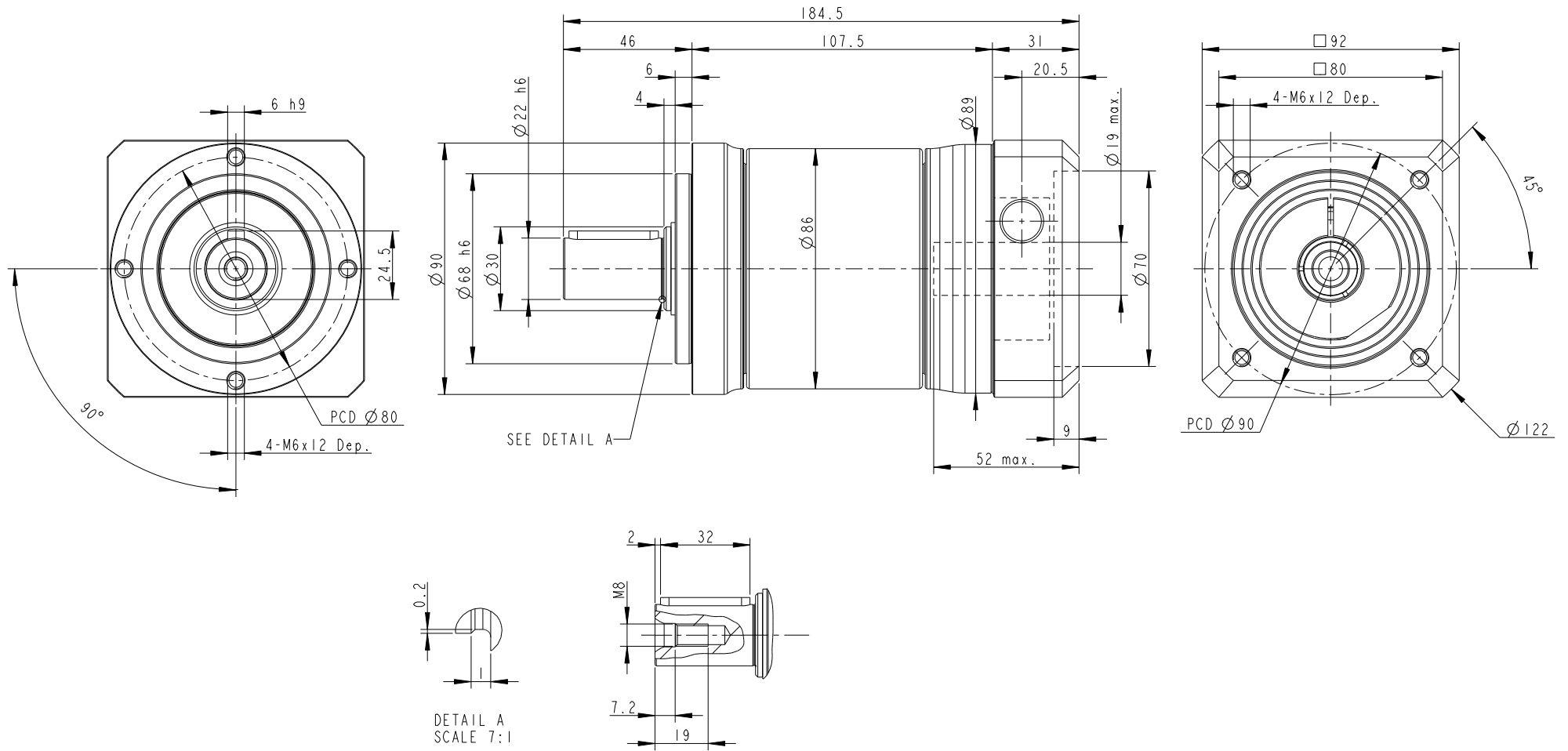

PE II 090 - 025 / MITSUBISHI HG-KR73



INERTIA: 1.63 ~ 1.77 kg-cm<sup>2</sup>  
 MASS: 3.9 Kg

PART NO. PE2-090_2ST_19-P0411400503 AD-PE2-S19-M80-3		 <b>APEX DYNAMICS, INC.</b>		
APPROVALS	DATE	TITLE PE2-090_2 Stages_S19 , RATIO= 12~100 AND MOTOR FLANGE MOUNTING		
DRAWN 沈正義				
CHECKED		DWG NO. PE2-090_2ST_19-P0411400503		
APPROVED			SIZE A2	SCALE 1:1
				REV