

The **MTV** series describes Linear Units with precision ball screw drive, integrated guide rail and compact dimensions. They provide high performances features, such as high speeds, good accuracy and repeatability.

They can easily be combined to multi-axis systems.

Excellent price-/performance ratio and quick delivery time are ensured.

The compact, precision-extruded aluminum Profile from 6063 AL with integrated Zero-backlash Ball rail guide system, allows high load capacities and optimal cycles for the movement of larger masses at high speed.

In the Linear Units MTV a precision ball screw, with tolerance class ISO7 (ISO5 on request), with reduced backlash of the ball nut is used.

A corrosion-resistant protection strip, protects all the parts in the profile from dust and other contaminants. The aluminum profile includes T-slots for fixing the Linear Unit and for attaching sensors and switches. Also, a Reed switch can be used here.

The carriage, with central lubrication port, allows easy central re-lubrication of ball screw and Ball rail guide and provides the possibility to attach additional accessories on the side.

For the Linear Units MTV various adaptation options, for attaching (or redirecting), for Motors or Gearboxes are available.

To achieve higher speeds at the same stroke of the linear unit, the ball screw support system can be integrated. With this feature vibrations and deflections of the ball screw are reduced, therefore longer strokes are possible. The linear unit with integrated support system can have a higher axial load capacity. Ball screw supports are made out of high quality plastic materials with high wear resistance properties. Our system enables ball screw support in horizontal or vertical positioning of the linear unit.

A 2LR version of MTV linear unit is available, where two carriages are moving simultaneously in opposite directions. Both right and left handed precision ball screws are used, which are rigidly connected. The ball screw support system can also be integrated.

i 2LR version of the MTV linear unit

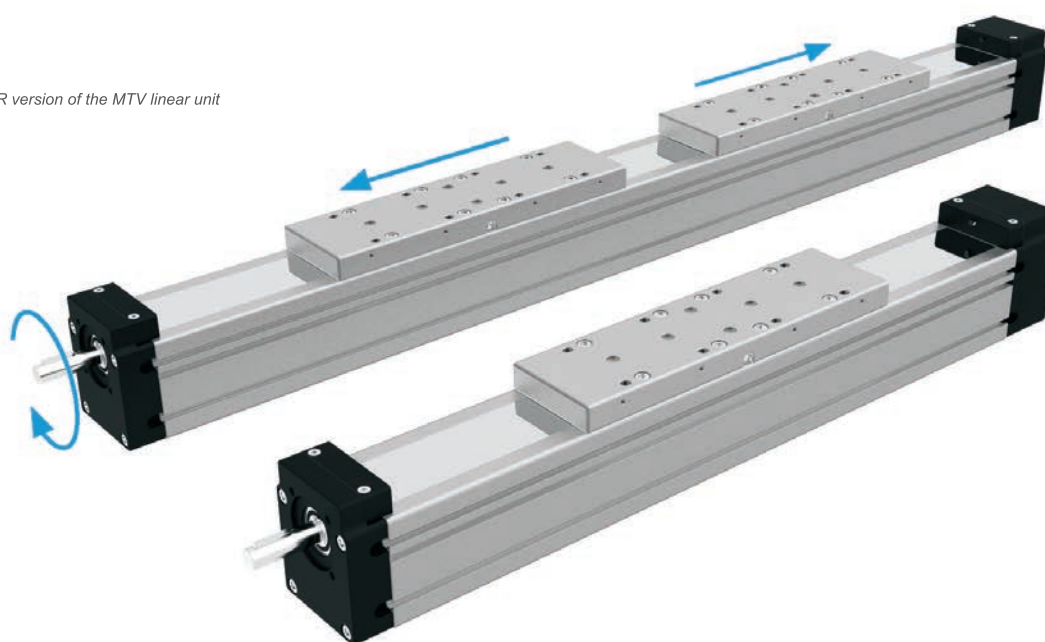

i The aluminium profiles are manufactured according to the medium EN 12020-2 standard

Straightness = 0,35 mm/m; Max. torsion = 0,35 mm/m; Angular torsion = 0,2 mm/40 mm; Parallelism = 0,2 mm

STRUCTURAL DESIGN

Standard version

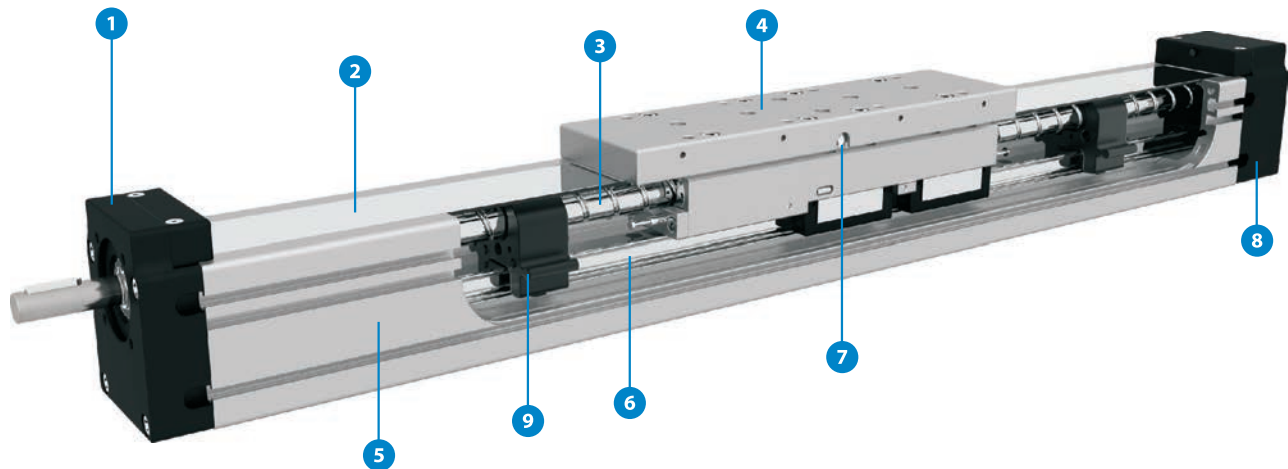

- 1 - Drive block with floating bearing (MTV 110 - fixed bearing)
- 2 - Corrosion-resistant protection strip
- 3 - Ball screw tolerance ISO7 (ISO5 available on request)
- 4 - Carriage; with built in Magnets
- 5 - Aluminium profile-Hard anodized
- 6 - Integrated Linear Ball Guideway
- 7 - Central lubrication port; both sides
- 8 - End block with fixed bearing (MTV 110 - floating bearing)
- 9 - Screw support - SA

2LR version

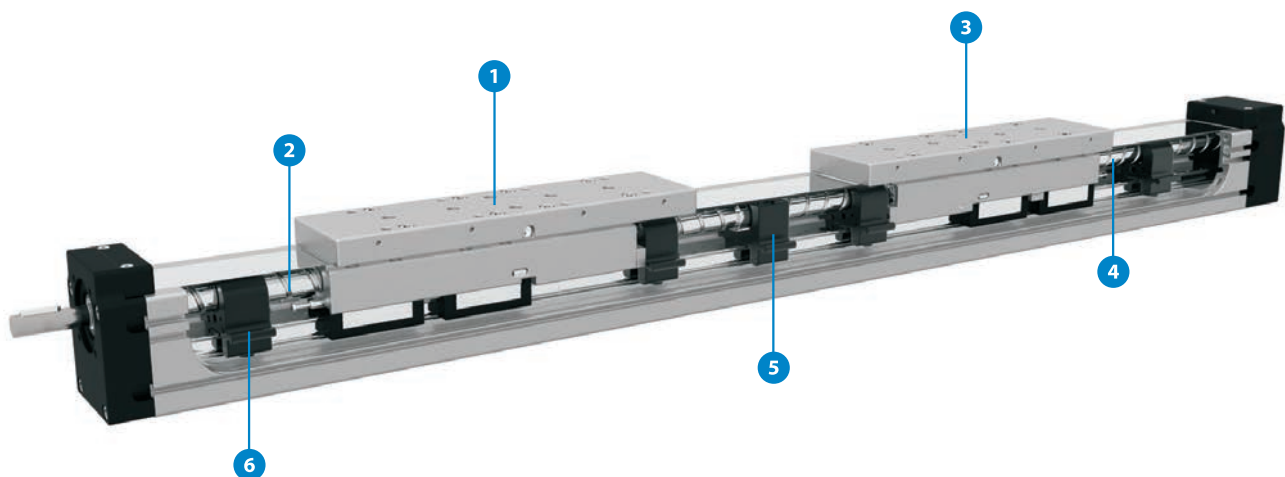

- 1 - Carriage; with built in right hand ball nut
- 2 - Right hand ball screw
- 3 - Carriage; with built in left hand ball nut
- 4 - Left hand ball screw
- 5 - Central screw support - fixed
- 6 - Screw support - SA

MTV - 65 - 1610 - ISO7 - 1 - 1000 - 2SA - 2LR

Series : _____

MTV

Size : _____

65

80

110

Ball screw : _____

MTV 65: Ø16×5, Ø16×10, Ø16×16

MTV 80: Ø20×5, Ø20×10, Ø20×20, Ø20×50

MTV 110: Ø32×5, Ø32×10, Ø32×20, Ø32×32

Ball screw tolerance : _____

ISO7 (Standard)

ISO5

Ball screw journal : _____

0 : Without keyway

1 : With keyway

Absolute stroke (mm) : _____

(Absolute stroke = Effective stroke + 2 x Safety stroke)

! *2LR version: Absolute stroke of one carriage.*

Number of screw supports n_{SA} : _____

(only even integer number - 2, 4, 6, 8, 10SA) - for MTV 65 max. 4SA is available

Leave blank : Without SA

2LR version : _____

Both right and left ball screws are used.

Leave blank : Standard version

! *Available for: MTV65: 16x5, 16x10
MTV80: 20x5*

TECHNICAL DATA

General technical data

Linear Unit	Carriage length Lv [mm]	Dynamic Load capacity C [N]	Dynamic moment			Max. permissible loads					* Max. length Lmax [mm]	* Max. stroke [mm]
			Mx [Nm]	My [Nm]	Mz [Nm]	Forces		Moments				
						Fpy [N]	Fpz [N]	Mpx [Nm]	Mpy [Nm]	Mpz [Nm]		
MTV 65	220	19800	158	700	700	6540	10190	94	350	233	2920	2690
MTV 65 2LR	220	19800	158	700	700	6540	10190	94	350	233	5789	2667

* For lengths / stroke over the stated value in the table above please contact us.
Values for max. stroke are not valid for screw support SA.
For the case of the SA the equation of defining the linear unit length (for particular size of the linear unit) needs to be used.

i Recommended values of loads:

All the data of dynamic moments and load capacities stated in the upper table are theoretical without considering any safety factor. The safety factor depends on the application and its requested safety. We recommend a minimum safety factor (fs = 5.0)

Modulus of elasticity

$E = 70000 \text{ N / mm}^2$

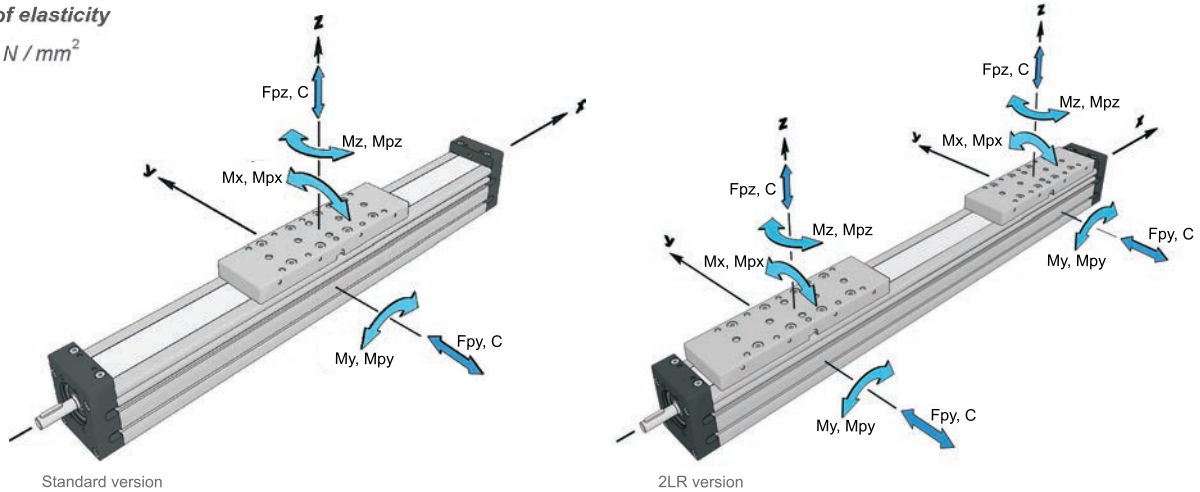

Operating conditions	
Operating temp.	0°C ~ +60°C
Duty cycle	100%

For operating temperature out of the presented range, please contact us.

Ball Screw Drive data

Linear Unit	Ball screw [d × l]	3 Max. rotational speed (Without SA) [rev / min]	1 Max. travel speed (Without SA) [m / s]	Lead constant [mm / rev]	2 Max. Repeatability precision [mm]		Dynamic load capacity BS Ca [N]	5 Max. axial load Fx [N]	Max. drive torque Ma [Nm]	4 Min. stroke [mm]	1 Max. acceleration [m/s ²]
					STANDARD ISO7	ISO5					
MTV 65 MTV 65 2LR	16 × 5	4200	0,35	5	± 0,02	± 0,01	13150	8700	5,5 with Keyway 7,7 without Keyway	40	20
	16 × 10										
	16 × 16										

1 Max. travel speed depends of the length of the linear unit, see diagram for particular size of the linear unit.
For travel speed and acceleration over the stated value in the table above or diagrams please contact us.

2 For the ball nut with the preload of 2%, please contact us.

3 With SA or 2LR version the max. rotation speed is limited to 3000 rev / min.

4 For minimum stroke below the stated value in the table above please contact us.

5 In the case of 2LR version the axial load is total axial load of both carriages.

Mass, moved mass, mass moment of inertia and no load torque

Linear Unit	Ball screw [d × l]	Number of SA n _{SA}	Mass of linear unit [kg]	Moved mass [kg]	Mass moment of inertia [10 ⁻⁵ kg * m ²]	* No load torque [Nm]
MTV 65	16 × 5	0	4,0 + 0,0073 * Stroke [mm]	1,50	1,6 + 0,0052 * Stroke [mm]	0,11
		2	4,5 + 0,0073 * Stroke [mm]	1,58	1,9 + 0,0052 * Stroke [mm]	0,13
		4	5,0 + 0,0073 * Stroke [mm]	1,66	2,2 + 0,0052 * Stroke [mm]	0,15
	16 × 5 2LR version	0	7,2 + 0,0146 * Stroke [mm]	3,00	2,9 + 0,0104 * Stroke [mm]	0,22
		2	8,2 + 0,0146 * Stroke [mm]	3,16	3,5 + 0,0104 * Stroke [mm]	0,26
		4	9,2 + 0,0146 * Stroke [mm]	3,32	4,1 + 0,0104 * Stroke [mm]	0,29
	16 × 10	0	4,0 + 0,0073 * Stroke [mm]	1,50	1,9 + 0,0052 * Stroke [mm]	0,12
		2	4,5 + 0,0073 * Stroke [mm]	1,58	2,2 + 0,0052 * Stroke [mm]	0,16
		4	5,0 + 0,0073 * Stroke [mm]	1,66	2,5 + 0,0052 * Stroke [mm]	0,19
	16 × 10 2LR version	0	7,2 + 0,0146 * Stroke [mm]	3,00	3,5 + 0,0104 * Stroke [mm]	0,24
		2	8,2 + 0,0146 * Stroke [mm]	3,16	4,1 + 0,0104 * Stroke [mm]	0,28
		4	9,2 + 0,0146 * Stroke [mm]	3,32	4,8 + 0,0104 * Stroke [mm]	0,31
	16 × 16	0	4,0 + 0,0073 * Stroke [mm]	1,50	2,5 + 0,0052 * Stroke [mm]	0,13
		2	4,5 + 0,0073 * Stroke [mm]	1,58	2,8 + 0,0052 * Stroke [mm]	0,19
		4	5,0 + 0,0073 * Stroke [mm]	1,66	3,2 + 0,0052 * Stroke [mm]	0,24

* The stated values are for strokes up to 500mm.
 No Load Torque value increases with stroke elongation.

 Mass calculation doesn't include mass of motor, reduction gear, switches and clamps.

Planar moment of inertia

Linear Unit	Planar moment of inertia	
	I _y [cm ⁴]	I _z [cm ⁴]
MTV 65 MTV 65 2LR	71,3	89,4

TECHNICAL DATA

Deflection of the linear unit

Fixed - fixed mounting

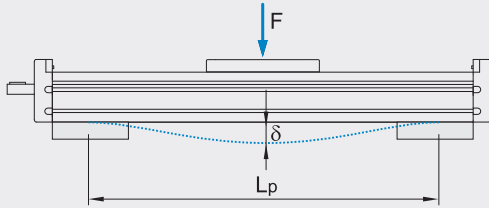

Fixed - free mounting

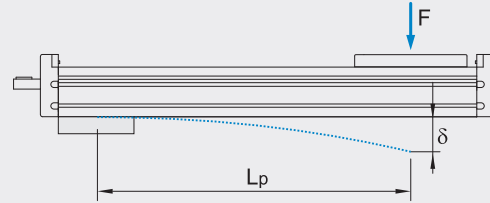

- δ Maximum deflection of the linear unit [mm]
- δ_{max} Maximum permissible deflection of the linear unit [mm]
- F Applied force [N]
- L_p Unsupported profile length [mm]



The maximum permissible deflection δ_{max} must not be exceeded. In the case that maximum deflection δ exceeds the maximum permissible deflection δ_{max} additional profile supports are needed.

MTV 65

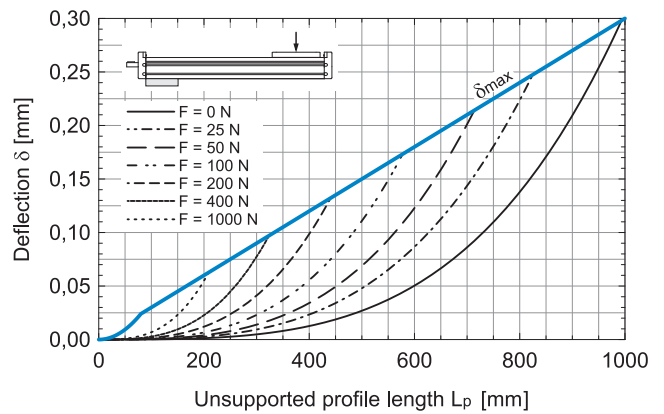
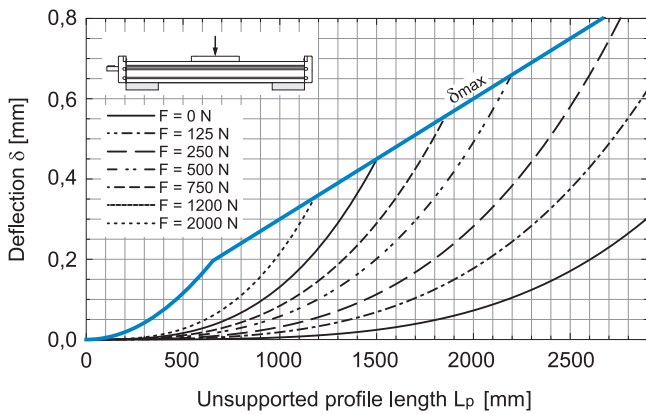

Maximum travel speed as a function of the profile length (Vmax - L curves)

MTV 65

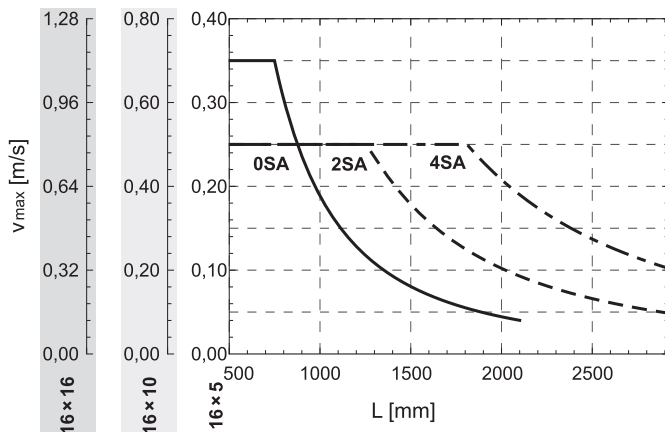

Deflection of the 2LR version

Fixed - fixed mounting

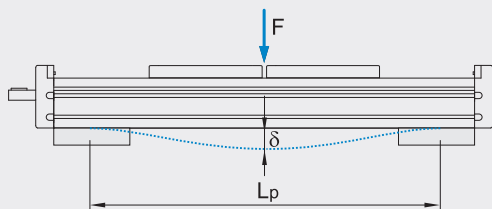

- δ Maximum deflection of the linear unit [mm]
- δ_{max} Maximum permissible deflection of the linear unit [mm]
- F Applied force [N]
- L_p Unsupported profile length [mm]

i The maximum permissible deflection δ_{max} must not be exceeded. In the case that maximum deflection δ exceeds the maximum permissible deflection δ_{max} additional profile supports are needed.

MTV 65 2LR

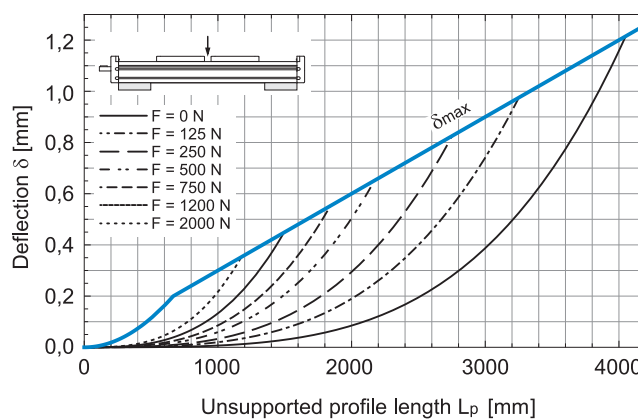

Maximum travel speed as a function of the profile length (Vmax - L curves)

MTV 65 2LR

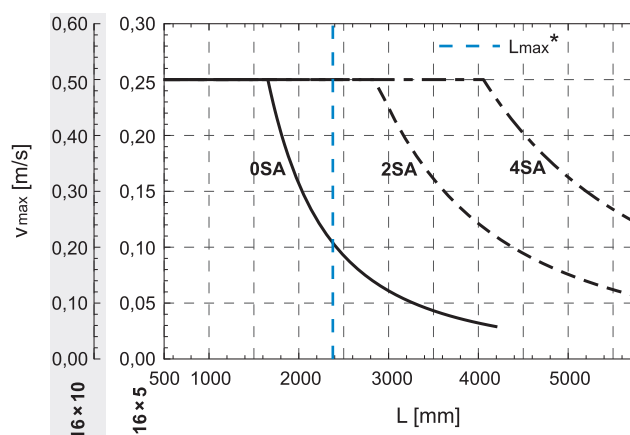

* Max. length L_{max} of MTV 65 2LR linear unit with 16x10 ball screw.

DIMENSIONS

i Linear Unit doesn't include any safety
Absolute stroke = Effective stroke + 2 x Safety stroke stroke.

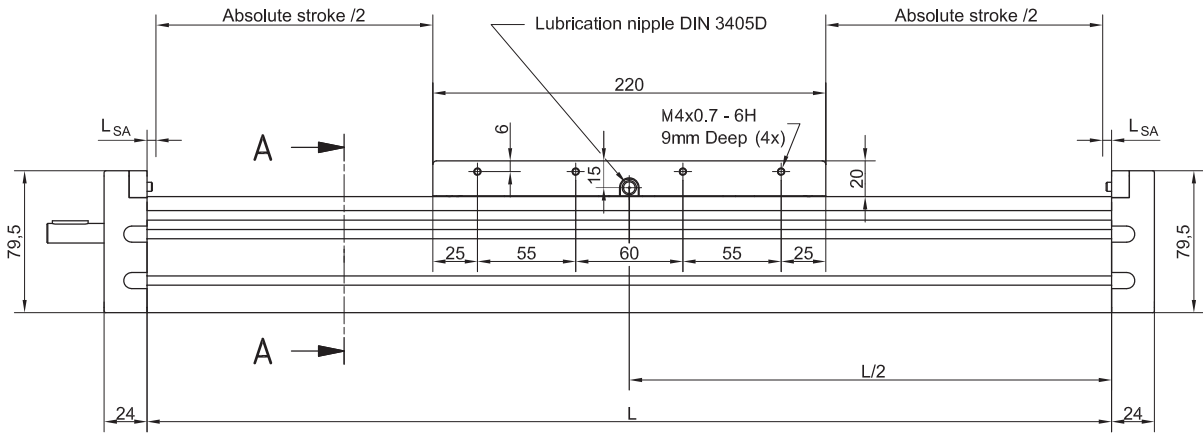

i Journal with or without keyway.

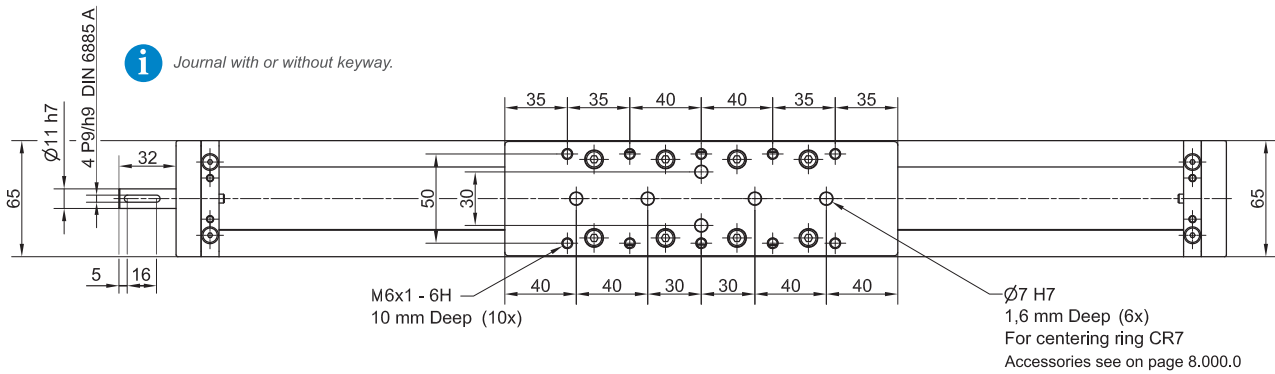

n	L _{SA}
0	5,0
2SA	31,0
4SA	62,0

L_{SA} Additional length [mm]

i All dimensions in mm:
Drawings scales are not equal.

2LR version

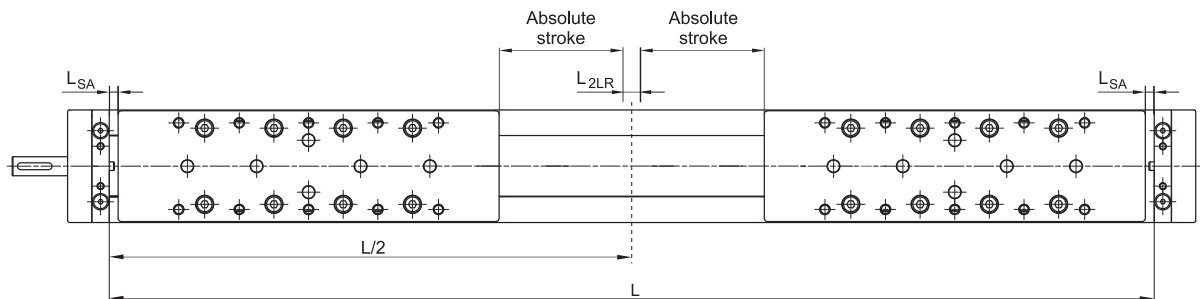

n	L _{SA}	L _{2LR}
0	5,0	5,0
2SA	31,0	67,0
4SA	62,0	129,0

L_{SA} Additional length [mm]

L_{2LR} Min. distance between carriages [mm]

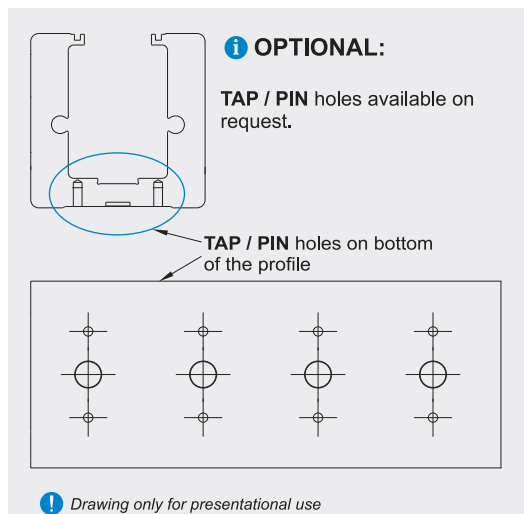
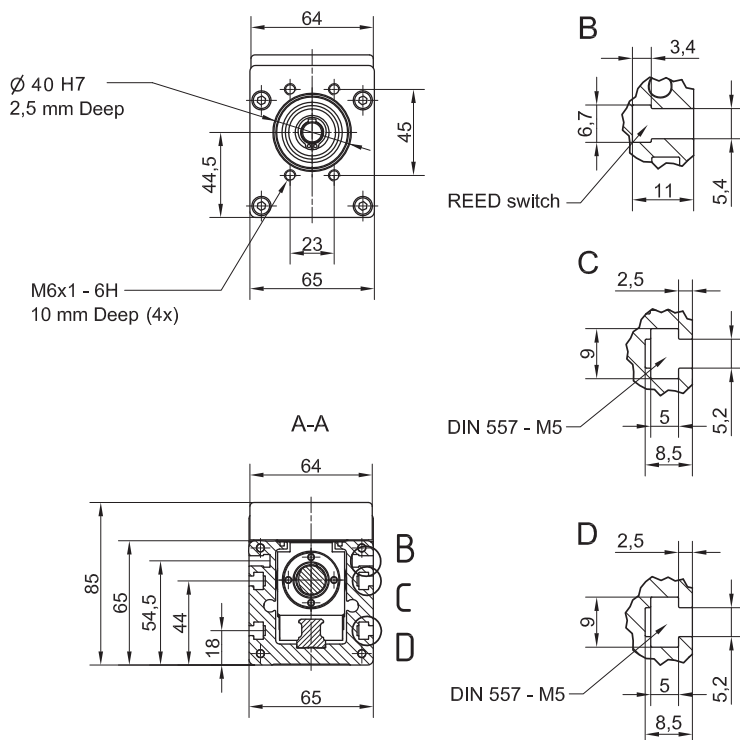

i All dimensions in mm.
Drawings scales are not equal.

Mounting the drive

- by the **MOTOR SIDE DRIVE - MSD** (Page 7.095.0)
- by the **MOTOR ADAPTER WITH COUPLING** (Page 8.020.0)

i Available on request.

Defining of the linear unit length

i Standard version

$L = \text{Effective stroke} + 2 \times \text{Safety stroke} + L_v + 2 \times L_{sa}$

$L_{total} = L + 48 \text{ mm}$

$L_v = 220 \text{ mm}$

Left side (L)

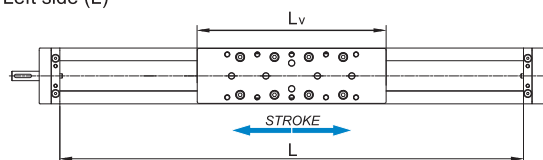

Right side (R)

i Version 2LR

$L = 2 \times (\text{Effective stroke} + 2 \times \text{Safety stroke}) + 2 \times L_v + 2 \times L_{sa} + L_{2LR}$

$L_{total} = L + 48 \text{ mm}$

$L_v = 220 \text{ mm}$

Left side (L)

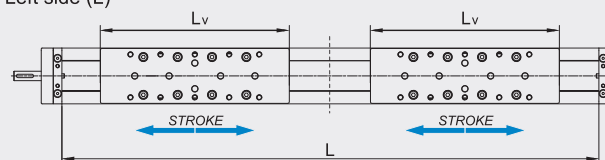

Right side (R)

TECHNICAL DATA

General technical data

Linear Unit	Carriage length Lv [mm]	Dynamic Load capacity C [N]	Dynamic moment			Max. permissible loads					* Max. length Lmax [mm]	* Max. stroke [mm]
			Mx [Nm]	My [Nm]	Mz [Nm]	Forces		Moments				
						Fpy [N]	Fpz [N]	Mpx [Nm]	Mpy [Nm]	Mpz [Nm]		
MTV 80	290	34200	370	1470	1470	8930	15070	150	500	384	5480	5163
MTV 80 2LR	290	34200	370	1470	1470	8930	15070	150	500	384	11055	5224

* For lengths / stroke over the stated value in the table above please contact us.
Values for max. stroke are not valid for screw support SA.
For the case of the SA the equation of defining the linear unit length (for particular size of the linear unit) needs to be used.

i Recommended values of loads:

All the data of dynamic moments and load capacities stated in the upper table are theoretical without considering any safety factor. The safety factor depends on the application and its requested safety. We recommend a minimum safety factor (fs = 5.0)

Modulus of elasticity

$E = 70000 \text{ N / mm}^2$

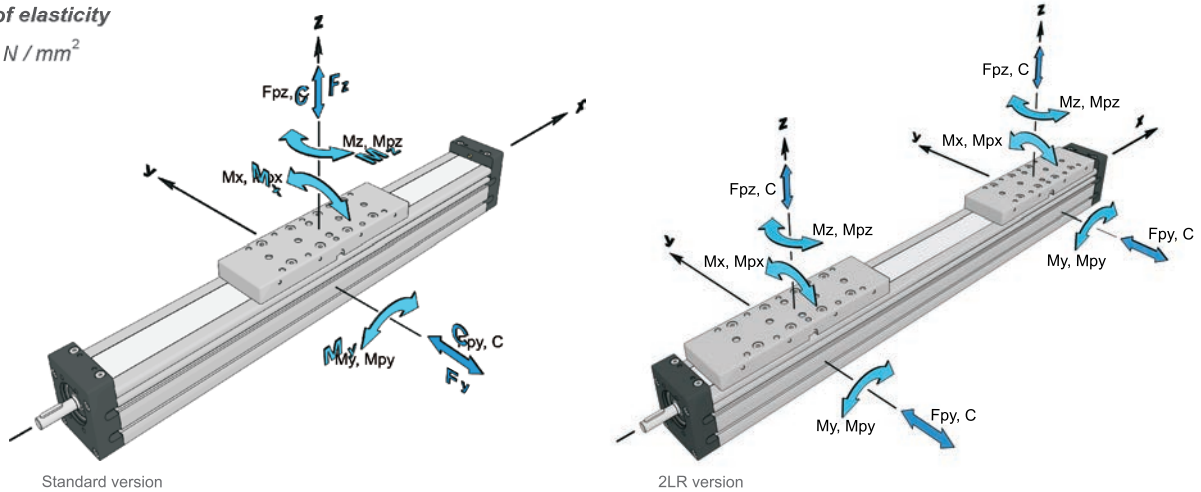

Operating conditions	
Operating temp.	0°C ~ +60°C
Duty cycle	100%

For operating temperature out of the presented range, please contact us.

Ball Screw Drive data

Linear Unit	Ball screw [d × l]	3 Max. rotational speed (Without SA) [rev / min]	1 Max. travel speed (Without SA) [m / s]	Lead constant [mm / rev]	2 Max. Repeatability precision [mm]		Dynamic load capacity BS Ca [N]	5 Max. axial load Fx [N]	Max. drive torque Ma [Nm]	4 Min. stroke [mm]	1 Max. acceleration [m/s ²]
					STANDARD ISO7	ISO5					
MTV 80 MTV 80 2LR	20 × 5	3300	0,28	5	± 0,02	± 0,01	14800	14800	11,9 with Keyway 13,0 without Keyway	55	20
	20 × 10										
	20 × 20										
	20 × 50	3000	2,50	50	± 0,02	± 0,01	13000	2770	11,9 with Keyway 24,5 without Keyway		

¹ Max. travel speed depends of the length of the linear unit, see diagram for particular size of the linear unit.
For travel speed and acceleration over the stated value in the table above or diagrams please contact us.

² For the ball nut with the preload of 2%, please contact us.

³ With SA or 2LR version the max. rotation speed is limited to 3000 rev / min.

⁴ For minimum stroke below the stated value in the table above please contact us.

⁵ In the case of 2LR version the axial load is total axial load of both carriages.

Mass, moved mass, mass moment of inertia and no load torque

Linear Unit	Ball screw [d × l]	Number of SA n _{SA}	Mass of linear unit [kg]	Moved mass [kg]	Mass moment of inertia [10 ⁻⁵ kg * m ²]	* No load torque [Nm]
MTV 80	20 × 5	0	8,2 + 0,0114 * Stroke [mm]	3,00	5,6 + 0,0127 * Stroke [mm]	0,16
		2	8,9 + 0,0114 * Stroke [mm]	3,07	6,2 + 0,0127 * Stroke [mm]	0,19
		4 / 6 / 8 / 10	9,7 + 0,4 * (n _{SA} - 4) + 0,0114 * Stroke [mm]	3,21 + 0,035 * (n _{SA} - 4)	7,0 + 0,4 * (n _{SA} - 4) + 0,0127 * Stroke [mm]	0,24 + 0,015 * (n _{SA} - 4)
	20 × 5 2LR Version	0	14,6 + 0,0228 * Stroke [mm]	6,00	9,5 + 0,0254 * Stroke [mm]	0,32
		2	15,9 + 0,0228 * Stroke [mm]	6,14	10,7 + 0,0254 * Stroke [mm]	0,37
		4 / 6 / 8 / 10	17,6 + 0,8 * (n _{SA} - 4) + 0,0228 * Stroke [mm]	6,42 + 0,07 * (n _{SA} - 4)	12,3 + 0,8 * (n _{SA} - 4) + 0,0254 * Stroke [mm]	0,48 + 0,03 * (n _{SA} - 4)
	20 × 10	0	8,2 + 0,0114 * Stroke [mm]	3,00	6,2 + 0,0127 * Stroke [mm]	0,17
		2	8,9 + 0,0114 * Stroke [mm]	3,07	6,8 + 0,0127 * Stroke [mm]	0,22
		4 / 6 / 8 / 10	9,7 + 0,4 * (n _{SA} - 4) + 0,0114 * Stroke [mm]	3,21 + 0,035 * (n _{SA} - 4)	7,6 + 0,4 * (n _{SA} - 4) + 0,0127 * Stroke [mm]	0,33 + 0,025 * (n _{SA} - 4)
	20 × 20	0	8,2 + 0,0114 * Stroke [mm]	3,00	8,5 + 0,0127 * Stroke [mm]	0,18
		2	8,9 + 0,0114 * Stroke [mm]	3,07	9,1 + 0,0127 * Stroke [mm]	0,29
		4 / 6 / 8 / 10	9,7 + 0,4 * (n _{SA} - 4) + 0,0114 * Stroke [mm]	3,21 + 0,035 * (n _{SA} - 4)	10,1 + 0,5 * (n _{SA} - 4) + 0,0127 * Stroke [mm]	0,50 + 0,055 * (n _{SA} - 4)
	20 × 50	0	8,2 + 0,0114 * Stroke [mm]	3,00	24,4 + 0,0127 * Stroke [mm]	0,58
		2	8,9 + 0,0114 * Stroke [mm]	3,07	25,5 + 0,0127 * Stroke [mm]	0,85
		4 / 6 / 8 / 10	9,7 + 0,4 * (n _{SA} - 4) + 0,0114 * Stroke [mm]	3,21 + 0,035 * (n _{SA} - 4)	27,1 + 0,6 * (n _{SA} - 4) + 0,0127 * Stroke [mm]	1,38 + 0,0135 * (n _{SA} - 4)

* The stated values are for strokes up to 500mm.
 No Load Torque value increases with stroke elongation.

 Mass calculation doesn't include mass of motor, reduction gear, switches and clamps.

Planar moment of inertia

Linear Unit	Planar moment of inertia	
	I _y [cm ⁴]	I _z [cm ⁴]
MTV 80 MTV 80 2LR	144,1	192,3

TECHNICAL DATA

Deflection of the linear unit

Fixed - fixed mounting

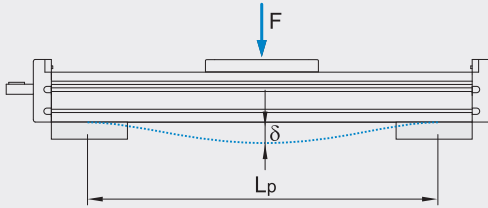

Fixed - free mounting

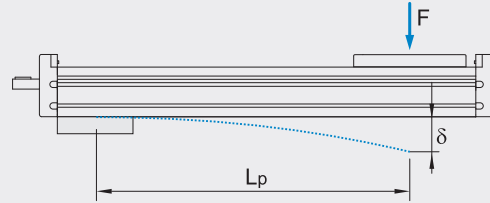

- δ Maximum deflection of the linear unit [mm]
- δ_{max} Maximum permissible deflection of the linear unit [mm]
- F Applied force [N]
- L_p Unsupported profile length [mm]

i The maximum permissible deflection δ_{max} must not be exceeded. In the case that maximum deflection δ exceeds the maximum permissible deflection δ_{max} additional profile supports are needed.

MTV 80

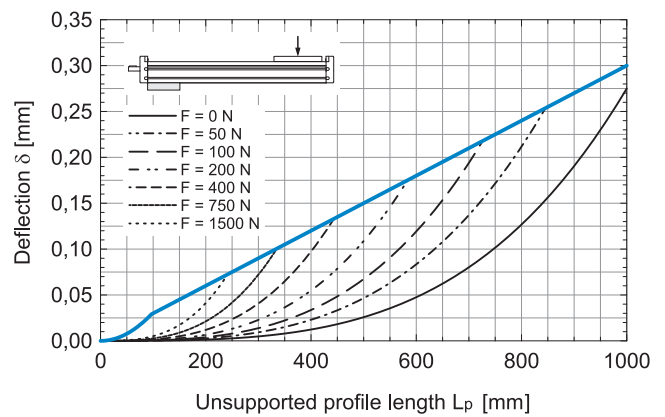
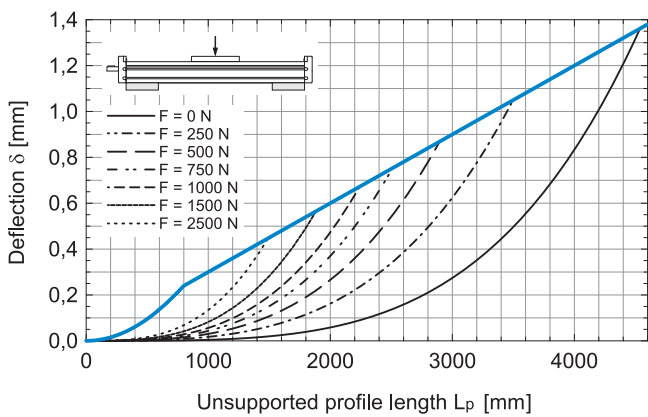

Maximum travel speed as a function of the profile length (Vmax - L curves)

MTV 80

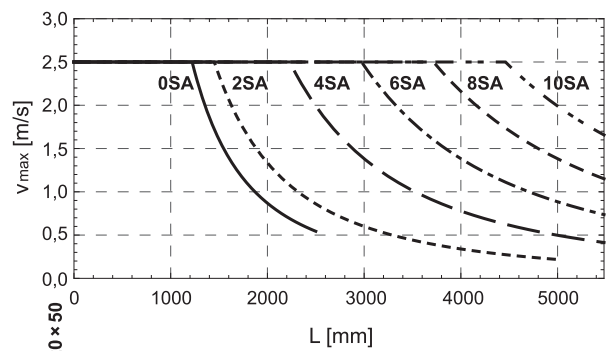
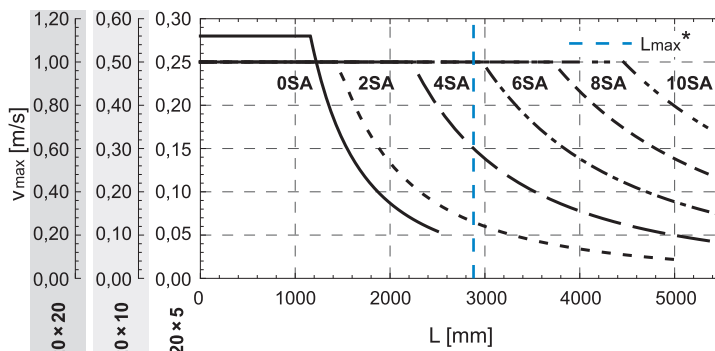

* Max. length L_{max} of MTV 80 linear unit with 20x10 ball screw.

Deflection of the 2LR version

Fixed - fixed mounting

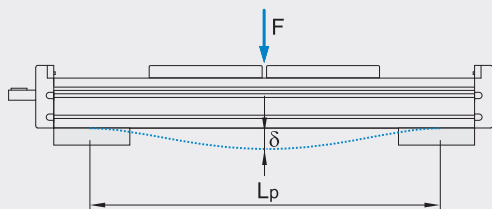

- δ Maximum deflection of the linear unit [mm]
- δ_{max} Maximum permissible deflection of the linear unit [mm]
- F Applied force [N]
- L_p Unsupported profile length [mm]

i The maximum permissible deflection δ_{max} must not be exceeded. In the case that maximum deflection δ exceeds the maximum permissible deflection δ_{max} additional profile supports are needed.

MTV 80 2LR

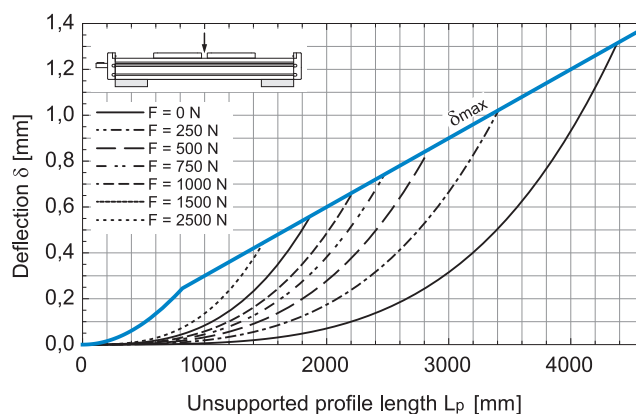

Maximum travel speed as a function of the profile length (Vmax - L curves)

MTV 80 2LR

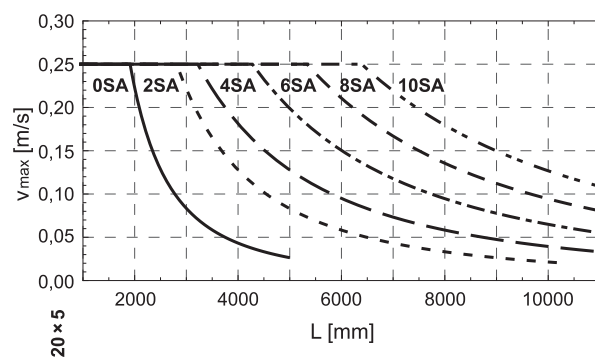

DIMENSIONS

i Linear Unit doesn't include any safety
Absolute stroke = Effective stroke + 2 x Safety stroke stroke.

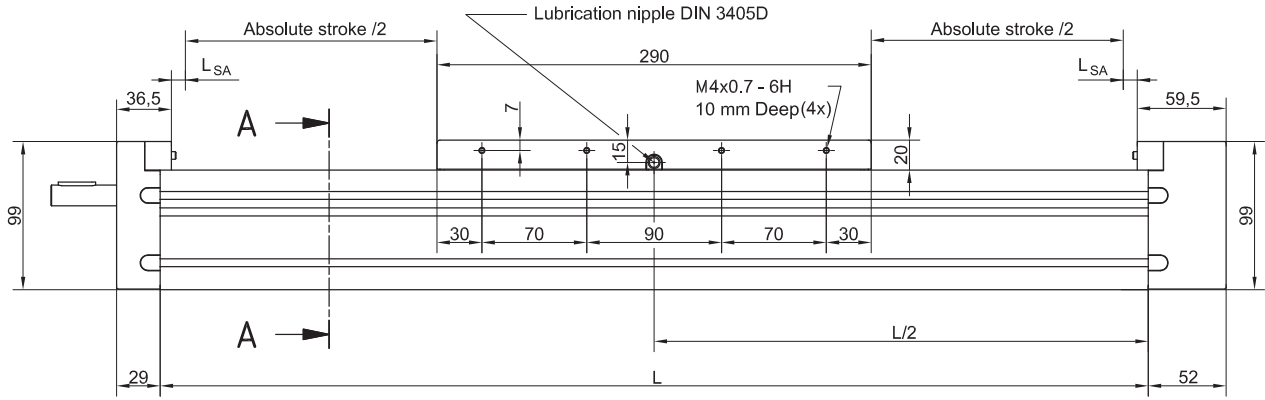

i Journal with or without keyway.

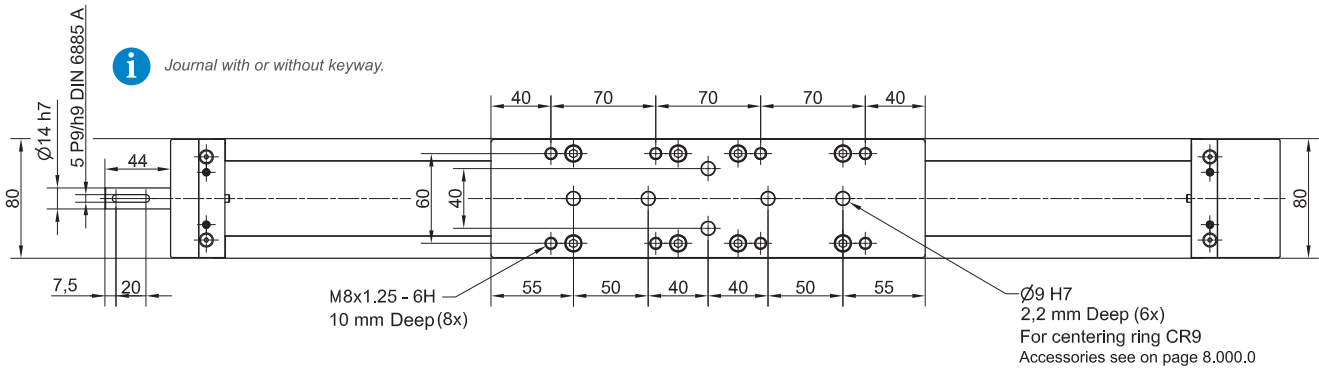

n_{SA}	L_{SA}
0	6,0
2SA	28,5
4SA	59,5
6SA	90,5
8SA	121,5
10SA	152,5

i All dimensions in mm;
Drawings scales are not equal.

L_{SA} Additional length [mm]

2LR Version

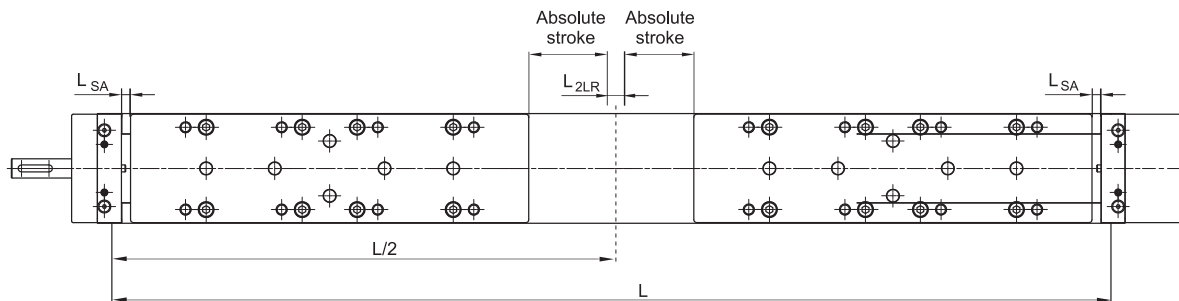

n_{SA}	L_{SA}	L_{2LR}
0	6,0	0,0
2SA	28,5	48,0
4SA	59,5	110,0
6SA	90,5	172,0
8SA	121,5	234,0
10SA	152,5	296,0

L_{SA} Additional length [mm]

L_{2LR} Min. distance between carriages [mm]

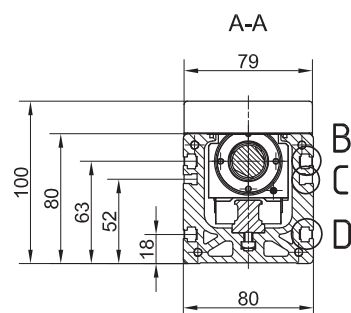
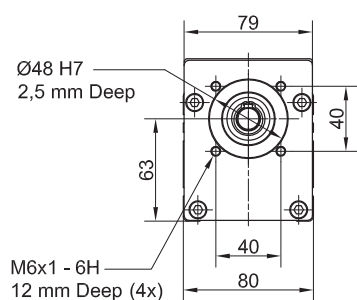

i All dimensions in mm.
Drawings scales are not equal.

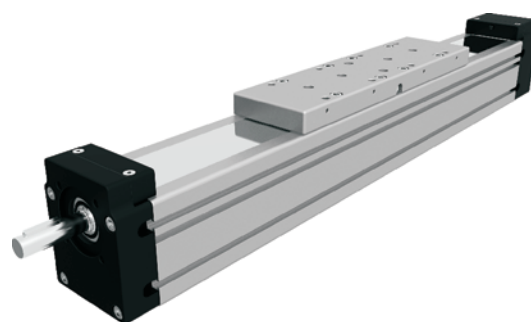
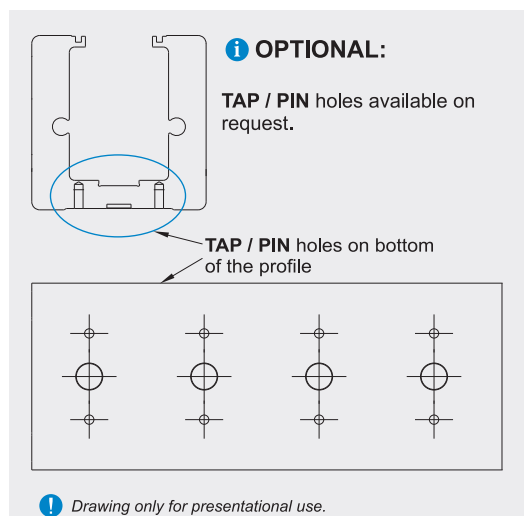
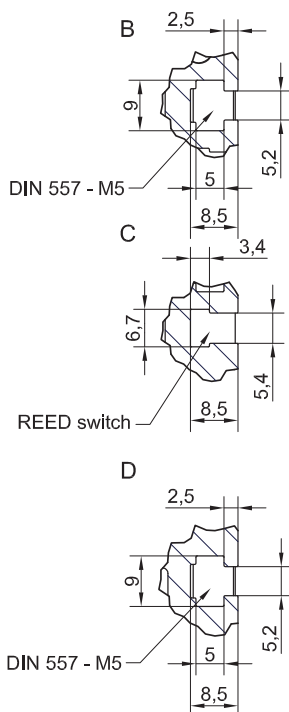

Mounting the drive

- by the **MOTOR SIDE DRIVE - MSD** (Page 7.095.0)
- by the **MOTOR ADAPTER WITH COUPLING** (Page 8.020.0)

i Available on request.

Defining of the linear unit length

i Standard version

$L = \text{Effective stroke} + 2 \times \text{Safety stroke} + L_v + 2 \times L_{SA} + 15 \text{ mm}$

$L_{\text{total}} = L + 81 \text{ mm}$

$L_v = 290 \text{ mm}$

Left side (L)

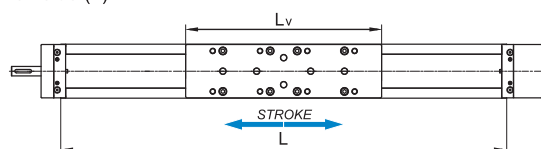

Right side (R)

i 2LR version

$L = 2 \times (\text{Effective stroke} + 2 \times \text{Safety stroke}) + 2 \times L_v + 2 \times L_{SA} + L_{2LR} + 15 \text{ mm}$

$L_{\text{total}} = L + 81 \text{ mm}$

$L_v = 290 \text{ mm}$

Left side (L)

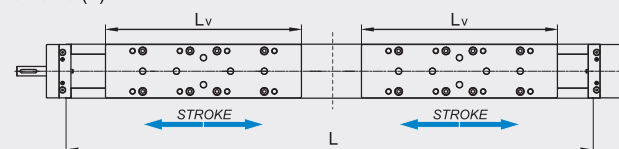

Right side (R)

TECHNICAL DATA

General technical data

Linear Unit	Carriage length Lv [mm]	Dynamic Load capacity C [N]	Dynamic moment			Max. permissible loads					* Max. length Lmax [mm]	* Max. stroke [mm]
			Mx [Nm]	My [Nm]	Mz [Nm]	Forces		Moments				
MTV 110	330	49600	630	2650	2650	Fpy [N]	Fpz [N]	Mpx [Nm]	Mpy [Nm]	Mpz [Nm]	5850	5456

* For lengths / stroke over the stated value in the table above please contact us.
Values for max. stroke are not valid for screw support SA.
For the case of the SA the equation of defining the linear unit length (for particular size of the linear unit) needs to be used.

Operating conditions	
Operating temp.	0°C ~ +60°C
Duty cycle	100%

For operating temperature out of the presented range, please contact us.

i Recommended values of loads:

All the data of dynamic moments and load capacities stated in the upper table are theoretical without considering any safety factor. The safety factor depends on the application and its requested safety. We recommend a minimum safety factor (fs =5.0)

Modulus of elasticity

$E = 70000 \text{ N / mm}^2$

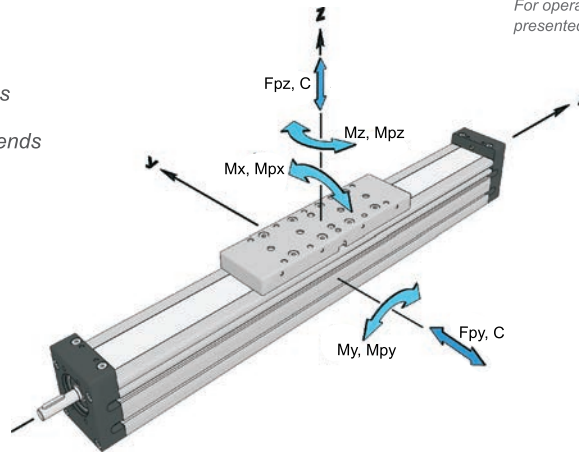

Ball Screw Drive data

Linear Unit	Ball screw [d × l]	3 Max. rotational speed (Without SA) [rev / min]	1 Max. travel speed (Without SA) [m / s]	Lead constant [mm / rev]	2 Max. Repeatability precision [mm]		Dynamic load capacity BS Ca [N]	5 Max. axial load Fx [N]	Max. drive torque Ma [Nm]	4 Min. stroke [mm]	1 Max. acceleration [m/s ²]
					STANDARD ISO7	ISO5					
MTV 110	32 × 5	2150	0,18	5	± 0,02	± 0,01	18850	18850	16,7 with Keyway 16,7 without Keyway	65	20
	32 × 10										
	32 × 20	3000	1,00	20	± 0,02	± 0,01	29700	14800			
	32 × 32								1,60		

1 Max. travel speed depends of the length of the linear unit, see diagram for particular size of the linear unit.
For travel speed and acceleration over the stated value in the table above or diagrams please contact us.
2 For the ball nut with the preload of 2%, please contact us.
3 With SA or 2LR version the max. rotation speed is limited to 3000 rev / min.
4 For minimum stroke below the stated value in the table above please contact us.
5 In the case of 2RL version the axial load is total axial load of both carriages.

Planar moment of inertia

Linear Unit	Planar moment of inertia	
	Iy [cm ⁴]	Iz [cm ⁴]
MTV 110	562,0	669,0

Mass, moved mass, mass moment of inertia and no load torque

Linear Unit	Ball screw [d × l]	Number of SA n _{SA}	Mass of linear unit [kg]	Moved mass [kg]	Mass moment of inertia [10 ⁻⁵ kg · m ²]	* No load torque [Nm]
MTV 110	32 × 5	0	17,3 + 0,0216 * Stroke [mm]	4,90	34,6 + 0,0690 * Stroke [mm]	0,45
		2	17,7 + 0,0216 * Stroke [mm]	5,03	35,1 + 0,0690 * Stroke [mm]	0,52
		4 / 6 / 8 / 10	19,3 + 0,8 * (n _{SA} - 4) + 0,0216 * Stroke [mm]	5,29 + 0,065 * (n _{SA} - 4)	39,4 + 2,2 * (n _{SA} - 4) + 0,0690 * Stroke [mm]	0,66 + 0,035 * (n _{SA} - 4)
	32 × 10	0	17,3 + 0,0216 * Stroke [mm]	4,90	35,5 + 0,0690 * Stroke [mm]	0,50
		2	17,7 + 0,0216 * Stroke [mm]	5,03	36,1 + 0,0690 * Stroke [mm]	0,64
		4 / 6 / 8 / 10	19,3 + 0,8 * (n _{SA} - 4) + 0,0216 * Stroke [mm]	5,29 + 0,065 * (n _{SA} - 4)	40,4 + 2,2 * (n _{SA} - 4) + 0,0690 * Stroke [mm]	0,92 + 0,070 * (n _{SA} - 4)
	32 × 20	0	17,3 + 0,0216 * Stroke [mm]	4,90	39,3 + 0,0690 * Stroke [mm]	0,55
		2	17,7 + 0,0216 * Stroke [mm]	5,03	39,9 + 0,0690 * Stroke [mm]	0,83
		4 / 6 / 8 / 10	19,3 + 0,8 * (n _{SA} - 4) + 0,0216 * Stroke [mm]	5,29 + 0,065 * (n _{SA} - 4)	44,4 + 2,2 * (n _{SA} - 4) + 0,0690 * Stroke [mm]	1,40 + 0,140 * (n _{SA} - 4)
	32 × 32	0	17,3 + 0,0216 * Hub [mm]	4,90	47,0 + 0,0690 * Stroke [mm]	0,60
		2	17,7 + 0,0216 * Hub [mm]	5,03	47,8 + 0,0690 * Stroke [mm]	1,05
		4 / 6 / 8 / 10	19,3 + 0,8 * (n _{SA} - 4) + 0,0216 * Stroke [mm]	5,29 + 0,065 * (n _{SA} - 4)	52,8 + 2,3 * (n _{SA} - 4) + 0,0690 * Stroke [mm]	1,96 + 0,225 * (n _{SA} - 4)

* The stated values are for strokes up to 500mm.
No Load Torque value increases with stroke elongation.

i Mass calculation doesn't include mass of motor, reduction gear, switches and clamps.

Deflection of the linear unit

Fixed - fixed mounting

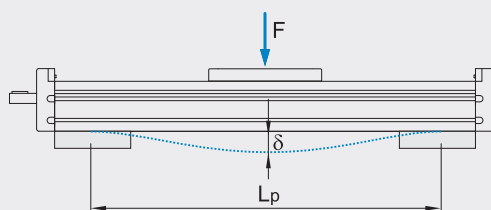

Fixed - free mounting

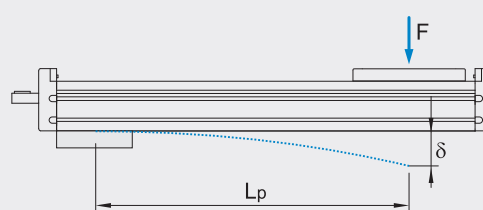

- δ Maximum deflection of the linear unit [mm]
- δ_{max} Maximum permissible deflection of the linear unit [mm]
- F Applied force [N]
- L_p Unsupported profile length [mm]

i The maximum permissible deflection δ_{max} must not be exceeded. In the case that maximum deflection δ exceeds the maximum permissible deflection δ_{max} additional profile supports are needed.

MTV 110

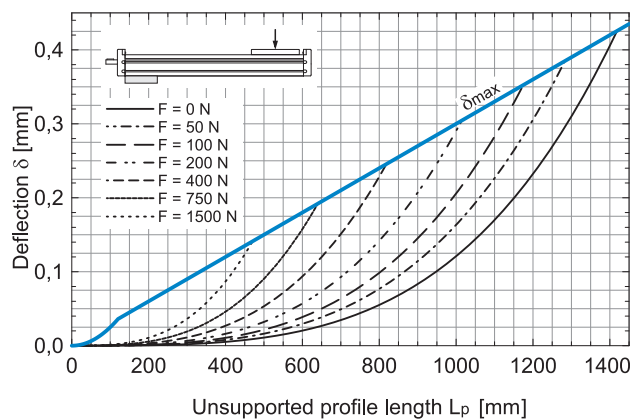
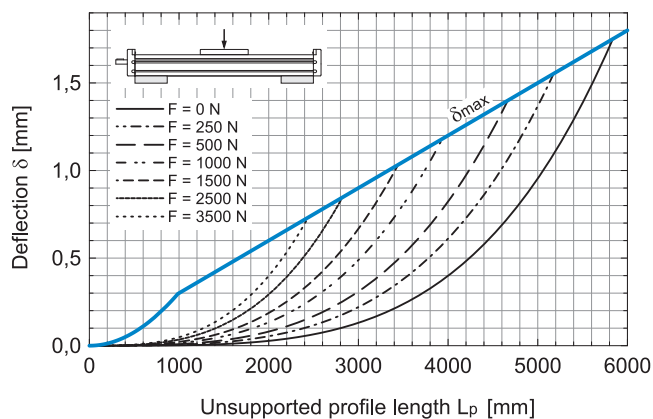

DIMENSIONS

i Linear Unit doesn't include any safety
Absolute stroke = Effective stroke + 2 x Safety stroke stroke.

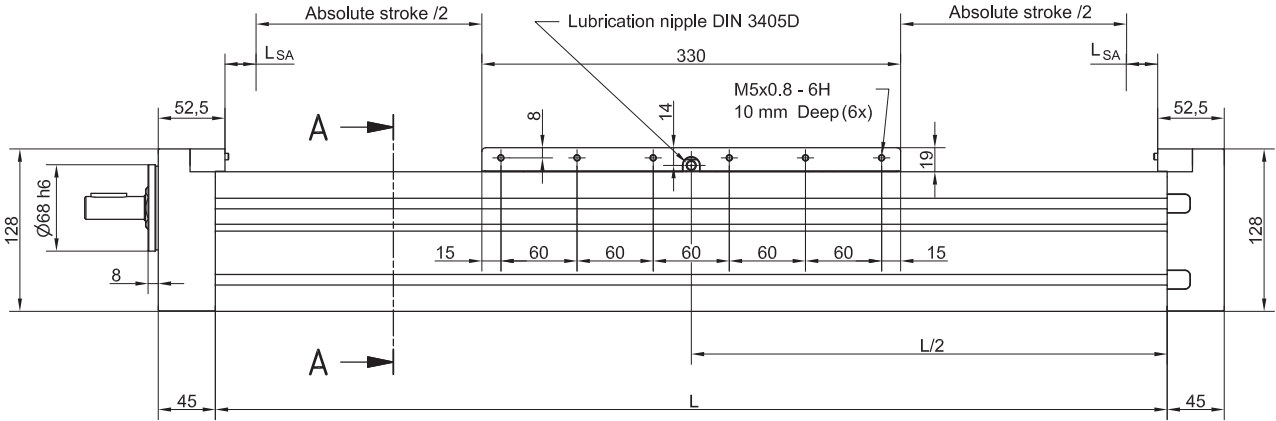

i Journal with or without keyway.

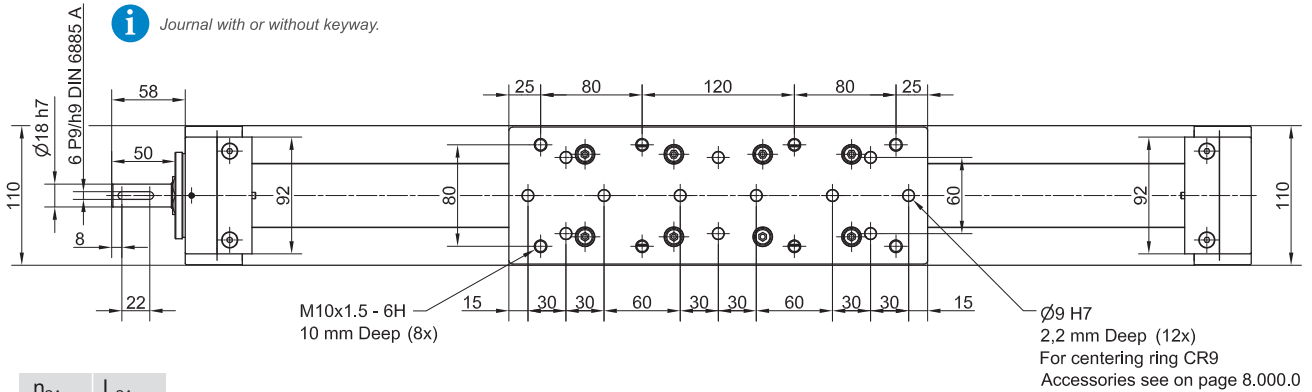

n _{SA}	L _{SA}
0	24,5
2SA	28,0
4SA	59,0
6SA	90,0
8SA	121,0
10SA	152,0

i All dimensions in mm;
Drawings scales are not equal.

L_{SA} Additional length [mm]

Defining of the linear unit length

L = Effective stroke + 2 × Safety stroke + Lv + 2 × L_{SA} + 15 mm

L_v = 330 mm

L_{total} = L + 90 mm

Left side (L)

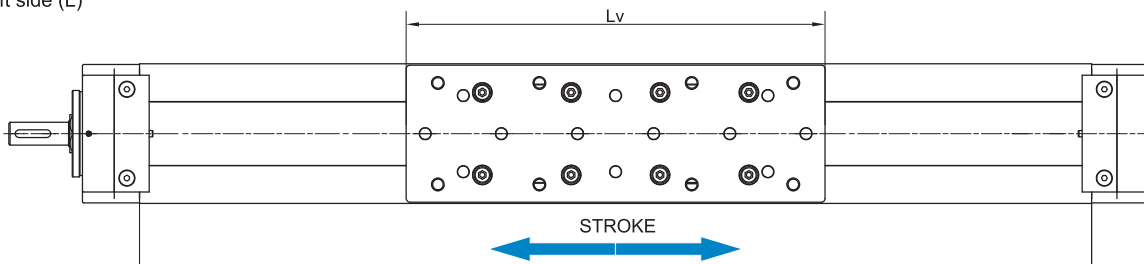

Right side (R)

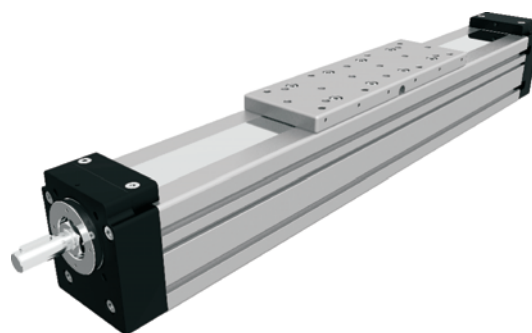
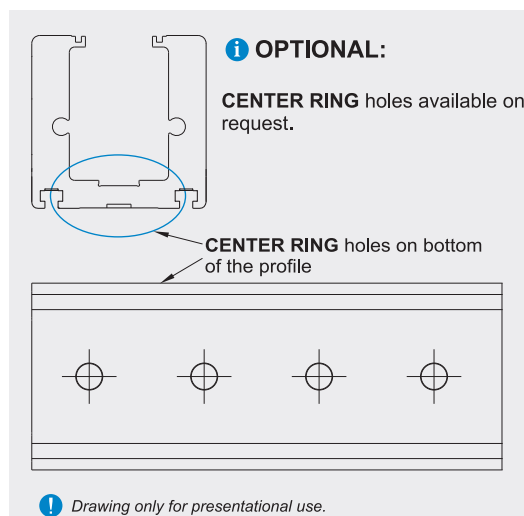
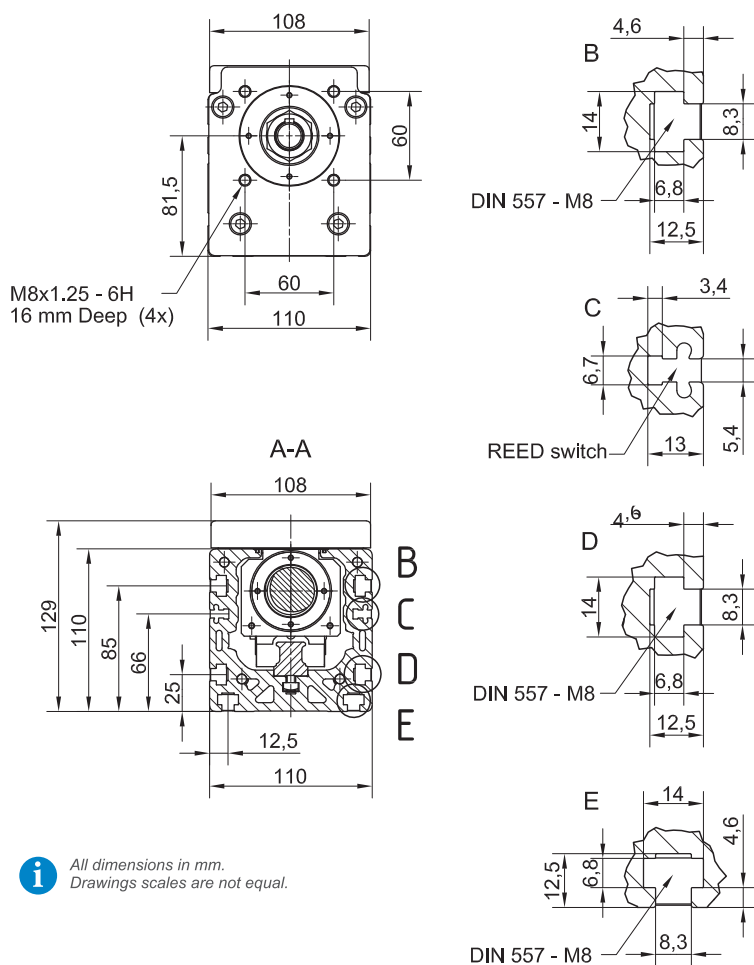

i All dimensions in mm.
Drawings scales are not equal.

Mounting the drive

- by the **MOTOR SIDE DRIVE - MSD** (Page 7.095.0)
- by the **MOTOR ADAPTER WITH COUPLING** (Page 8.020.0)

i Available on request.

Maximum travel speed as a function of the profile length (V_{max} - L curves)

